

HIGH FREQUENCY WIRE WOUND TRANSFORMERS

EP13 Platforms - SMT



- Power Range:** Up to 60W
- Height:** 12.7mm Max
- Footprint:** 17.7mm x 14.0mm Max
- Topology:** Forward and Flyback

Electrical Specifications @ 25°C — Operating Temperature -40°C to 130°C ⁵

PA1136NL	Pri. Inductance	(3-4)	126.7μH ±10%	<p>FLYBACK TRANSFORMER</p>
	Lk. Inductance	(3-4) with (10,9,8,7) shorted	7.5μH MAX	
	DCR	(3-4)	440mΩ MAX	
		(8,7-10,9)	6mΩ MAX	
		(2-1)	88mΩ MAX	
	Hi-Pot	Pri-Sec	1500Vrms	
K1 Factor	1353.6			
PA1137NL	Pri. Inductance	(3-4)	126.7μH ±10%	<p>FLYBACK TRANSFORMER</p>
	Lk. Inductance	(3-4) with (10,9,8,7) shorted	7.5μH MAX	
	DCR	(3-4)	460mΩ MAX	
		(8,7-10,9)	12mΩ MAX	
		(2-1)	94mΩ MAX	
	Hi-Pot	Pri-Sec	1500Vrms	
K1 Factor	1353.6			
PA1138NL	Pri. Inductance	(3-4)	126.7μH ±10%	<p>FLYBACK TRANSFORMER</p>
	Lk. Inductance	(3-4) with (10,9,8,7) shorted	7.5μH MAX	
	DCR	(3-4)	460mΩ MAX	
		(8,7-10,9)	55mΩ MAX	
		(2-1)	94mΩ MAX	
	Hi-Pot	Pri-Sec	1500Vrms	
K1 Factor	1353.6			
PA1210NL	Pri. Inductance	(3-4)	88μH ±10%	<p>FLYBACK TRANSFORMER</p>
	Lk. Inductance	(3-4) with (10,9,8,7,6) shorted	7.5μH MAX	
	DCR	(3-4)	370mΩ MAX	
		(8,7-10,9)	6mΩ MAX	
		(2-1)	145mΩ MAX	
	(6-8,7)	30mΩ MAX		
Hi-Pot	Pri-Sec	1500Vrms		
K1 Factor	1128.2			
PA1218NL	Pri. Inductance	(3-4)	480μH ±10%	<p>FLYBACK TRANSFORMER</p>
	Lk. Inductance	(3-4) with (10,8,7,6) shorted	10μH MAX	
	DCR	(3-4)	570mΩ MAX	
		(8-10)	15mΩ MAX	
		(6-7)	40mΩ MAX	
		(2-1)	325mΩ MAX	
Hi-Pot	Pri-Sec	1500Vrms		
K1 Factor	5128.2			
PA1260NL	Pri. Inductance	(3-4)	77.4μH ±10%	<p>FLYBACK TRANSFORMER</p>
	Lk. Inductance	(3-4) with (10,9,8,7) shorted	0.8μH MAX	
	DCR	(3-4)	220mΩ MAX	
		(8,7-10,9)	18mΩ MAX	
		(2-1)	250mΩ MAX	
	Hi-Pot	Pri-Sec	1500Vrms	
K1 Factor	1804.2			

HIGH FREQUENCY WIRE WOUND TRANSFORMERS

EP13 Platforms - SMT



Electrical Specifications @ 25°C — Operating Temperature -40°C to 130°C⁵

PA1267NL	Pri. Inductance	(4-1)	155.5μH ±10%	<p>FLYBACK TRANSFORMER</p>
	Lk. Inductance	(4-1) with (10,9,8,7) shorted	5μH MAX	
	DCR	(4-1)	330mΩ MAX	
		(7,8-9,10)	11mΩ MAX	
		(5-2)	650mΩ MAX	
	Hi-Pot	Pri-Sec	1500Vrms	
K1 Factor	2215.1			
PA1269NL	Pri. Inductance	(3-4)	77.4μH ±10%	<p>FLYBACK TRANSFORMER</p>
	Lk. Inductance	(3-4) with (10,9,8,7) shorted	0.8μH MAX	
	DCR	(3-4)	100mΩ MAX	
		(8,7-10,9)	6.5mΩ MAX	
		(2-1)	270mΩ MAX	
	Hi-Pot	Pri-Sec	1500Vrms	
K1 Factor	1804.2			
PA1276NL	Pri. Inductance	(3-4)	77.4μH ±10%	<p>FLYBACK TRANSFORMER</p>
	Lk. Inductance	(3-4) with (10,9,8,7) shorted	0.8μH MAX	
	DCR	(3-4)	100mΩ MAX	
		(8,7-10,9)	75mΩ MAX	
		(2-1)	270mΩ MAX	
	Hi-Pot	Pri-Sec	1500Vrms	
K1 Factor	1804.2			
PA1309NL	Pri. Inductance	(3-4)	16.4μH ±10%	<p>FLYBACK TRANSFORMER</p>
	Lk. Inductance	(3-4) with (10,9,8,7) shorted	0.7μH MAX	
	DCR	(3-4)	38mΩ MAX	
		(8,7-10,9)	10mΩ MAX	
		(2-1)	200mΩ MAX	
	Hi-Pot	Pri-Sec	1500Vrms	
K1 Factor	559.0			
PA1367NL	Pri. Inductance	(3,4-2,1)	104.2μH ±30%	<p>FORWARD TRANSFORMER</p>
	Lk. Inductance	(3,4-2,1) with (10,9,8,7) shorted	0.25μH MAX	
	DCR	(3,4-2,1)	20mΩ MAX	
		(7-9)	355mΩ MAX	
		(8-10)	405mΩ MAX	
	Hi-Pot	Pri-Sec	1500Vrms	
K1 Factor	57.0			
PA1460NL	Pri. Inductance	(3,4)	40μH ±10%	<p>FLYBACK TRANSFORMER</p>
	Lk. Inductance	(3,4) with (10,9,8,7) shorted	2.5μH MAX	
	DCR	(3,4)	95mΩ MAX	
		(8,7-10,9)	28mΩ MAX	
		(2-1)	66mΩ MAX	
	Hi-Pot	Pri-Sec	1650Vrms	
K1 Factor	1025.6			
PA1528NL	Pri. Inductance	(3,4)	28.9μH ±10%	<p>FLYBACK TRANSFORMER</p>
	Lk. Inductance	(3,4) with (10,9,8,7) shorted	1μH MAX	
	DCR	(3,4)	58mΩ MAX	
		(8,7-10,9)	27mΩ MAX	
		(2-1)	55mΩ MAX	
	Hi-Pot	Pri-Sec	1500Vrms	
K1 Factor	871.8			

HIGH FREQUENCY WIRE WOUND TRANSFORMERS

EP13 Platforms - SMT



Electrical Specifications @ 25°C — Operating Temperature -40°C to 130°C⁵

PA1576NL	Pri. Inductance	(3,4)	230.4μH ±30%	
	Lk. Inductance	(3,4) with (10,9,8,7) shorted	1.5μH MAX	
	DCR	(3,4)	36mΩ MAX	
		(8,7-10,9)	3.5mΩ MAX	
		(2-1)	58mΩ MAX	
	Hi-Pot	Pri-Sec	1500Vrms	
K1 Factor	42.7			
PA1577NL	Pri. Inductance	(3,4)	230.4μH ±30%	
	Lk. Inductance	(3,4) with (10,9,8,7) shorted	1.5μH MAX	
	DCR	(3,4)	36mΩ MAX	
		(7-9)=(8-10)	54mΩ MAX	
		(2-1)	55mΩ MAX	
	Hi-Pot	Pri-Sec	1500Vrms	
K1 Factor	42.7			
PA1686NL	Pri. Inductance	(3,4)	64μH ±10%	
	Lk. Inductance	(3,4) with (10,9,8,7) shorted	1.5μH MAX	
	DCR	(3,4)	75mΩ MAX	
		(8,7-10,9)	10mΩ MAX	
		(2-1)	120mΩ MAX	
	Hi-Pot	Pri-Sec	1500Vrms	
K1 Factor	1641.0			
PA1698NL	Pri. Inductance	(3,4)	57.6μH ±10%	
	Lk. Inductance	(3,4) with (10,9,8,7) shorted	3.5μH MAX	
	DCR	(3,4)	110mΩ MAX	
		(8,7-10,9)	6mΩ MAX	
		(2-1)	88mΩ MAX	
	Hi-Pot	Pri-Sec	1500Vrms	
K1 Factor	1230.8			
PA1718NL	Pri. Inductance	(3-4)	108μH ±7%	
	Lk. Inductance	(3-4) with (10,9,8,7,6) shorted	5μH MAX	
	DCR	(3-4)	260mΩ MAX	
		(8,7-10,9)	15mΩ MAX	
		(2-1)	165mΩ MAX	
	(6-8,7)	60mΩ MAX		
Hi-Pot	Pri-Sec	1500Vrms		
K1 Factor	1846.2			
PA1769NL	Pri. Inductance	(3,4)	6.7μH ±7%	
	Lk. Inductance	(3,4) with (10,9,8,7) shorted	0.65μH MAX	
	DCR	(3,4)	25mΩ MAX	
		(8,7-10,9)	6.5mΩ MAX	
		(2-1)	115mΩ MAX	
	Hi-Pot	Pri-Sec	1500Vrms	
K1 Factor	381.8			
PA1861NL	Pri. Inductance	(1,4)	115.5μH ±7%	
	Lk. Inductance	(1,4) with (10,9,8,7) shorted	0.65μH MAX	
	DCR	(1,4)	330mΩ MAX	
		(7,8-9,10)	11mΩ MAX	
		(5-2)	460mΩ MAX	
	Hi-Pot	Pri-Sec	1500Vrms	
K1 Factor	1645.3			

HIGH FREQUENCY WIRE WOUND TRANSFORMERS

EP13 Platforms - SMT



Electrical Specifications @ 25°C — Operating Temperature -40°C to 130°C⁵

PA2070NL	Pri. Inductance	(5-4)	164μH ±10%	<p>FLYBACK TRANSFORMER</p>
	Lk. Inductance	(5-4) with (10,9,8,7) shorted	3μH MAX	
	DCR	(5-4)	292mΩ MAX	
		(7,8-9,10)	8.5mΩ MAX	
		(2-1)	60mΩ MAX	
	Hi-Pot	Pri-Sec	1500Vrms	
K1 Factor	2628.2			
PA2086NL	Pri. Inductance	(2-3)	164μH ±10%	<p>FLYBACK TRANSFORMER</p>
	Lk. Inductance	(2-3) with (10,9,8,7) shorted	3μH MAX	
	DCR	(2-3)	292mΩ MAX	
		(5-4)	64mΩ MAX	
		(9-1)	17mΩ MAX	
	(7-8)	100mΩ MAX		
Hi-Pot	Pri-Sec	1500Vrms		
K1 Factor	2628.2			
PA2194NL	Pri. Inductance	(1-2)	617.4μH ±28%	<p>FORWARD TRANSFORMER</p> <p>* please note this part has an alternate pin-out per note 5.</p>
	Lk. Inductance	(1-2) with (10,9,7,6,5,4) shorted	0.75μH MAX	
	DCR	(1-2)	100mΩ MAX	
		(9,10-6,7)	15.5mΩ MAX	
	(4-5)	590mΩ MAX		
Hi-Pot	Pri-Sec	1500Vrms		
K1 Factor	24.4			
PA2204NL	Pri. Inductance	(2,3-4,5)	5μH ±28%	<p>FLYBACK TRANSFORMER</p>
	Lk. Inductance	(2,3-4,5) with (10,9,8,7) shorted	0.25μH MAX	
	DCR	(2,3-4,5)	20mΩ MAX	
	(8,7-10,9)	10.3mΩ MAX		
Hi-Pot	Pri-Sec	1500Vrms		
K1 Factor	320.5			
PA2221NL	Pri. Inductance	(5-4)	152μH ±10%	<p>FLYBACK TRANSFORMER</p>
	Lk. Inductance	(5-4) with (10,9,8,7) shorted	4μH MAX	
	DCR	(5-4)	280mΩ MAX	
		(7,8-9,10)	5.2mΩ MAX	
	(2-1)	67mΩ MAX		
Hi-Pot	Pri-Sec	1500Vrms		
K1 Factor	2435.9			
PA2271NL	Pri. Inductance	(3-4)	10μH ±10%	<p>FLYBACK TRANSFORMER</p>
	Lk. Inductance	(3-4) with (10,9,8,7) shorted	1μH MAX	
	DCR	(3-4)	23mΩ MAX	
		(8,7-10,9)	6.7mΩ MAX	
	(2-1)	54mΩ MAX		
	Hi-Pot	Pri-Sec	1500Vrms	
K1 Factor	512.8			

HIGH FREQUENCY WIRE WOUND TRANSFORMERS

EP13 Platforms - SMT



Electrical Specifications @ 25°C — Operating Temperature -40°C to 130°C⁵

PA2297NL	Pri. Inductance	(5-4)	50μH ±10%	<p>FLYBACK TRANSFORMER</p>
	Lk. Inductance	(5-4) with (10,9,8,7) shorted	4μH MAX	
	DCR	(5-4)	140mΩ MAX	
		(7,8-9,10)	3.5mΩ MAX	
		(2-1)	73mΩ MAX	
	Hi-Pot	Pri-Sec	1500Vrms	
K1 Factor	949.7			
PA2300NL	Pri. Inductance	(1-2)	85μH ±10%	<p>FLYBACK TRANSFORMER</p> <p>* please note this part has an alternate pin-out per note 5.</p>
	Lk. Inductance	(1-2) with (10,9,8,7,6,5,4) shorted	0.75μH MAX	
	DCR	(1-2)	325mΩ MAX	
		(9,10-6,7)	9mΩ MAX	
		(4-5)	815mΩ MAX	
	Hi-Pot	Pri-Sec	1500Vrms	
K1 Factor	1614.4			
PA2328NL	Pri. Inductance	(1-2)	100μH ±10%	<p>FORWARD TRANSFORMER</p>
	Lk. Inductance	(1-2) with (10,9,7,6,5,4) shorted	0.875μH MAX	
	DCR	(1-2)	210mΩ MAX	
		(6,7-9,10)	9mΩ MAX	
		(4-5)	580mΩ MAX	
	Hi-Pot	Pri-Sec	1500Vrms	
K1 Factor	18.3			
PA2367NL	Pri. Inductance	(2-1)	85μH ±28%	<p>FLYBACK TRANSFORMER</p>
	Lk. Inductance	(2-1) with (10,9,7,6,5,4) shorted	0.75μH MAX	
	DCR	(2-1)	325mΩ MAX	
		(9,10-6,7)	25.5mΩ MAX	
		(4-5)	815mΩ MAX	
	Hi-Pot	Pri-Sec	1500Vrms	
K1 Factor	1614.4			
PA2369NL	Pri. Inductance	(5-3)	37μH ±10%	<p>FLYBACK TRANSFORMER</p>
	Lk. Inductance	(5-3) with (6,7,9,10) shorted	0.75μH MAX	
	DCR	(5-3)	89mΩ MAX	
		(6,7-9,10)	6.2mΩ MAX	
		(2-1)	84mΩ MAX	
	Hi-Pot	Pri-Sec	1500Vrms	
K1 Factor	948.7			
PA2417NL	Pri. Inductance	(1-2)	530μH ±28%	<p>FORWARD TRANSFORMER</p>
	Lk. Inductance	(1-2) with (10,9,7,6,5,4) shorted	0.5μH MAX	
	DCR	(1-2)	750mΩ MAX	
		(6,7-9,10)	6.5mΩ MAX	
		(4-5)	886mΩ MAX	
	Hi-Pot	Pri-Sec	1500Vrms	
K1 Factor	25.6			

HIGH FREQUENCY WIRE WOUND TRANSFORMERS

EP13 Platforms - SMT



Electrical Specifications @ 25°C — Operating Temperature -40°C to 130°C⁵

PA2431NL	Pri. Inductance	(1-2)	429.3μH ±28%	<p>FORWARD TRANSFORMER</p>
	Lk. Inductance	(1-2) with (10,9,7,6,5,4) shorted	0.5μH MAX	
	DCR	(1-2)	68mΩ MAX	
		(6,7-9,10)	6.5mΩ MAX	
		(4-5)	970mΩ MAX	
	Hi-Pot	Pri-Sec	1500Vrms	
K1 Factor	28.5			
PA2437NL	Pri. Inductance	(1-4) with (3-2) shorted	80μH ±10%	<p>FLYBACK TRANSFORMER</p>
	Lk. Inductance	(1-4) with (3-2) and (9-10) shorted	TBDμH MAX	
	DCR	(1-3)	47mΩ MAX	
		(2-4)	58mΩ MAX	
		(6-7)	155mΩ MAX	
		(8-10)	12mΩ MAX	
Hi-Pot	Pri-Sec	1500Vrms		
K1 Factor	1709.4			
PA2452NL	Pri. Inductance	(1-2)	100μH ±10%	<p>FORWARD TRANSFORMER</p>
	Lk. Inductance	(1-2) with (10,9,7,6,5,4) shorted	TBDμH MAX	
	DCR	(1-2)	99mΩ MAX	
		(6,7-9,10)	6.6mΩ MAX	
		(4-5)	200mΩ MAX	
	Hi-Pot	Pri-Sec	1500Vrms	
K1 Factor	21.4			
PA2466NL	Pri. Inductance	(5-3)	37μH ±10%	<p>FLYBACK TRANSFORMER</p>
	Lk. Inductance	(5-3) with (6,7,9,10) shorted	0.75μH MAX	
	DCR	(5-3)	89mΩ MAX	
		(6,7-9,10)	4.6mΩ MAX	
		(2-1)	96mΩ MAX	
	Hi-Pot	Pri-Sec	1500Vrms	
K1 Factor	948.7			
PA2467NL	Pri. Inductance	(5-3)	37μH ±10%	<p>FLYBACK TRANSFORMER</p>
	Lk. Inductance	(5-3) with (6,7,9,10) shorted	0.75μH MAX	
	DCR	(5-3)	89mΩ MAX	
		(6,7-9,10)	28mΩ MAX	
		(2-1)	96mΩ MAX	
	Hi-Pot	Pri-Sec	1500Vrms	
K1 Factor	948.7			

HIGH FREQUENCY WIRE WOUND TRANSFORMERS

EP13 Platforms - SMT



Notes

- The temperature of the component (ambient plus temperature rise) must be within the stated operating temperature range.
- The above transformers and inductors have been tested and approved by Pulse's power IC partners and are sited in the appropriate datasheet or evaluation board documentation at these companies. To determine which IC and IC partners are matched with the above Pulse part numbers please consult the IC Cross Reference on the Pulse website.
- For flyback topology applications, it is necessary to ensure that the transformer will not saturate in the application. The peak flux density (Bpk) should remain below 2700Gauss. To calculate the peak flux density use the following formula:

$$\text{Bpk (Gauss)} = K1_Factor * I_{pk}(A)$$
- In high volt- μ sec applications, it is important to calculate the core loss of the transformer. Approximate transformer core loss can be calculated as:

$$\text{CoreLoss (W)} = 2.5E-14 * (\text{Freq_kHz})^{1.63} * (\Delta B_Gauss)^{2.63}$$
 where ΔB can be calculated as:
 For Flyback Topology: $\Delta B = K1_Factor * \Delta(A)$
 For Forward Topology: $\Delta B = K1_Factor * \text{Volt-}\mu\text{sec}$
- The standard pin-numbering for this package is indicated in the below mechanical drawing showing pin 1 on the lower right corner and the numbers proceeding clockwise to pin 10 on the upper right corner. However, for those parts that are indicated as having an alternate pin-out, pin 1 is in the lower left corner and the numbers proceed counter-clockwise to pin 10 in the upper left corner.
- Optional Tape & Reel packaging can be ordered by adding a "T" suffix to the part number (i.e. PA1136NL becomes PA1136NLT). Pulse complies with industry standard tape and reel specification EIA481. The tape and reel for this product has a width (W=32mm), pitch (Po=24mm) and depth (Ko=13.2mm).
- The "NL" suffix indicates an RoHS-compliant part number. Non-NL suffixed parts are not necessarily RoHS compliant, but are electrically and mechanically equivalent to NL versions. If a part number does not have the "NL" suffix, but an RoHS compliant version is required, please contact Pulse for availability.

Mechanical

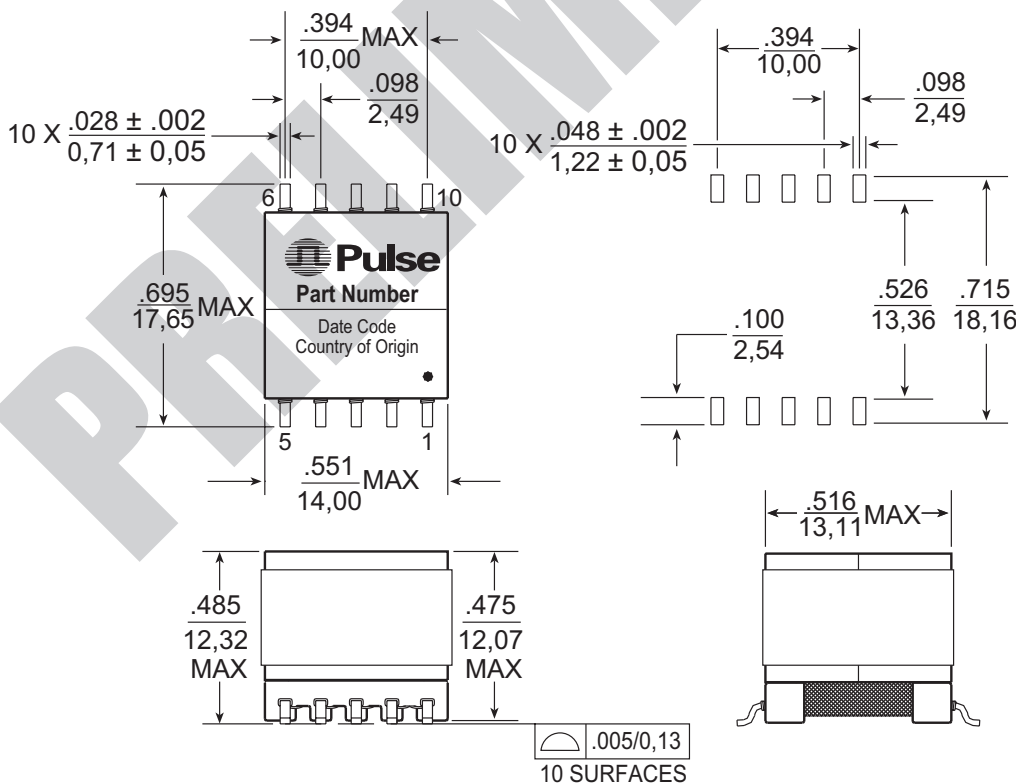

For More Information:

Pulse Worldwide Headquarters

12220 World Trade Dr.
San Diego, CA 92128
U.S.A.
www.pulseeng.com

TEL: 858 674 8100
FAX: 858 674 8262

Pulse European Headquarters

Einsteinstrasse 1
D-71083 Herrenberg
Germany

TEL: 49 7032 7806 0
FAX: 49 7032 7806 12

Pulse China Headquarters

B402, Shenzhen Academy of
Aerospace Technology Bldg.
10th Kejinan Rd.
High-Tech Zone
Nanshan District
Shenzhen, PR China 518057

TEL: 86 755 33966678
FAX: 86 755 33966700

Pulse North China

Room 1503
XinYin Building
No. 888 YiShan Rd.
Shanghai 200233
China

TEL: 86 21 32181071
FAX: 86 21 32181396

Pulse South Asia

150 Kampong Ampat
#07-01/02
KA Centre
Singapore 368324

TEL: 65 6287 8998
FAX: 65 6280 0080

Pulse North Asia

No. 26
Kao Ching Rd.
Yang Mei Chen
Taoyuan Hsien
Taiwan, R. O. C.
32667

TEL: 886 3 4643715
FAX: 886 3 4641911