

PAC5250

Data Sheet

Power Application Controller®

Multi-Mode Power Manager™

Configurable Analog Front End™

Application Specific Power Drivers™

Arm® Cortex®-M0 Controller Core



TABLE OF CONTENTS

1	General Description	8
2	PAC Family Applications	9
3	Product Selection Summary	10
4	Ordering Information	10
5	PAC5250 Features	11
6	Absolute Maximum Ratings	13
7	Architectural Block Diagram	14
8	Pin Configuration	15
8.1	PAC5250QF	15
9	Pin Description	16
10	Multi-Mode Power manager (MMPM)	22
10.1	Features	22
10.2	Block Diagram	22
10.3	Functional Description	23
10.3.1	Multi-Mode Switching Supply (MMSS) Controller	23
10.3.2	Linear Regulators	25
10.3.3	Power Up Sequence	26
10.3.4	Hibernate Mode	26
10.3.5	Power and Temperature Monitor	27
10.3.6	Voltage Reference	27
10.4	Electrical Characteristics	28
10.5	Typical Performance Characteristics	32
11	Configurable Analog Front End (CAFE)	33
11.1	Block Diagram	33
11.2	Functional Description	34
11.2.1	Differential Programmable Gain Amplifier (DA)	34
11.2.2	Single-Ended Programmable Gain Amplifier (AMP)	34
11.2.3	General Purpose Comparator (CMP)	34
11.2.4	Phase Comparator (PHC)	34
11.2.5	Protection Comparator (PCMP)	35
11.2.6	Analog Output Buffer (BUF)	35
11.2.7	Analog Front End I/O (AIO)	35
11.2.8	Push Button (PBTN)	35

11.2.9	HP DAC and LP DAC	35
11.2.10	ADC Pre-Multiplexer	36
11.2.11	Configurable Analog Signal Matrix (CASM)	36
11.2.12	Configurable Digital Signal Matrix (CDSM)	36
11.3	Electrical Characteristics	37
11.4	Typical Performance Characteristics	41
12	Application Specific Power Drivers (ASPD)	43
12.1	Features	43
12.2	Block Diagram	43
12.3	Functional Description	43
12.3.1	Low-Side Gate Driver	44
12.3.2	Ultra-High-Voltage Gate Driver	44
12.3.3	High-Side Switching Transients	45
12.3.4	Open-Drain Drivers	45
12.3.5	Power Drivers Control	45
12.3.6	Gate Driver Fault Protection	46
12.4	Electrical Characteristics	47
12.5	Typical Performance Characteristics	49
	Typical Performance Characteristics (Continued)	50
13	ADC With Auto-Sampling Sequencer	51
13.1	Block Diagram	51
13.2	Functional Description	51
13.2.1	ADC	51
13.2.2	Auto-Sampling Sequencer	51
13.2.3	EMUX Control	52
13.3	Electrical Characteristics	52
14	Memory System	53
14.1	Features	53
14.2	Block Diagram	53
14.3	Functional Description	53
14.3.1	Program and Data FLASH	53
14.3.2	SRAM	53
14.4	Electrical Characteristics	54
15	Clock Control System	55
15.1	Features	55

15.2	Block Diagram	55
15.3	Functional Description	56
15.3.1	Free Running Clock (FRCLK)	56
15.3.2	Fast Clock (FCLK)	56
15.3.3	High-Speed Clock (HCLK)	56
15.3.4	Auxiliary Clock (ACLK)	56
15.3.5	Clock Gating	56
15.3.6	Ring Oscillator (ROSC)	56
15.3.7	Trimmed 4MHz RC Oscillator	57
15.3.8	Internal Slow RC Oscillator	57
15.3.9	Crystal Oscillator Driver	57
15.3.10	External Clock Input	57
15.3.11	PLL	57
15.4	Electrical Characteristics	58
16	ARM® CORTEX®-M0 Microcontroller Core	59
16.1	Features	59
16.2	Block Diagram	59
16.3	Functional Description	59
16.4	Electrical Characteristics	60
16.5	Typical Performance Characteristics	60
17	I/O Controller	61
17.1	Features	61
17.2	Block Diagram	61
17.3	Functional Description	62
17.4	GPIO Current Injection	62
17.5	Electrical Characteristics	63
18	Serial Interface	64
18.1	Block Diagram	64
18.2	Functional Description	64
18.2.1	I ² C Controller	65
18.3	UART Controller	65
18.4	SPI Controller	65
18.5	Dynamic Characteristics	66
19	Timers	70
19.1	Block Diagram	70

19.2	Functional Description	71
19.2.1	Timer A.....	71
19.2.2	Timer B.....	71
19.2.3	Timer C.....	72
19.2.4	Timer D.....	72
19.2.5	Watchdog Timer	72
19.2.6	CAFE Watchdog Timer	72
19.2.7	Wake-Up Timer	72
19.2.8	Real-Time Clock.....	72
20	Thermal Characteristics	73
21	Application Examples.....	74
22	Package Outline And Dimensions.....	76
22.1	TQFN1010-57 Package Outline and Dimensions	76

LIST OF TABLES

Table 3-1	Product Selection Summary	10
Table 4-1	Ordering Information	10
Table 6-1	Absolute Maximum Ratings	13
Table 9-1	Multi-Mode Power Manager and System Pin Description	16
Table 9-2	Configurable Analog Front End Pin Description	17
Table 9-3	Application Specific Power Drivers Pin Description	18
Table 9-4	I/O Ports Pin Description.....	19
Table 9-5	I/O Ports Pin Description (Continued).....	20
Table 10-1	Multi-Mode Switching Supply Controller Electrical Characteristics	28
Table 10-2	Linear Regulators Electrical Characteristics	30
Table 10-3	Power System Electrical Characteristics	31
Table 11-1	Differential Programmable Gain Amplifier (DA) Electrical Characteristics	37
Table 11-2	Single-Ended Programmable Gain Amplifier (AMP) Electrical Characteristics	38
Table 11-3	General Purpose Comparator (CMP) Electrical Characteristics.....	38
Table 11-4	Phase Comparator (PHC) Electrical Characteristics	39
Table 11-5	Protection Comparator (PCMP) Electrical Characteristics	39
Table 11-6	Analog Output Buffer (BUF) Electrical Characteristics	39
Table 11-7	Analog Front End I/O (AIO) Electrical Characteristics.....	40
Table 11-8	Push Button (PBTN) Electrical Characteristics.....	40
Table 11-9	HP DAC and LP DAC Electrical Characteristics.....	40
Table 12-1	Power Driver Resources by Part Number.....	44
Table 12-2	Microcontroller Port and PWM to Power Driver Mapping	46
Table 12-3	Power Driver Propagation Delay.....	46
Table 12-4	Gate Drivers Electrical Characteristics	47
Table 12-5	Open-Drain Drivers Electrical Characteristics	48
Table 12-6	Power Drivers Module Electrical Characteristics	48
Table 13-1	ADC and Auto-Sampling Sequencer Electrical Characteristics.....	52
Table 14-1	Memory System Electrical Characteristics	54
Table 15-1	Clock Control System Electrical Characteristics.....	58
Table 16-1	Microcontroller and Clock Control System Electrical Characteristics	60
Table 17-1	I/O Controller Electrical Characteristics	63
Table 18-1	Serial Interface Dynamic Characteristics.....	66
Table 18-2	I ² C Dynamic Characteristics	67
Table 18-3	SPI Dynamic Characteristics	69
Table 20-1	Thermal Characteristics	73
Table 22-1	Dimensions	77

LIST OF FIGURES

Figure 1-1	Power Application Controller	8
Figure 2-1	Simplified Application Diagram.....	9
Figure 7-1	Architectural Block Diagram	14
Figure 8-1	PAC5250QF Pin Configuration (TQFN1010-57 Package).....	15
Figure 9-1	Power Supply Bypass Capacitor Routing	21
Figure 10-1	Multi-Mode Power Manager	22
Figure 10-2	Buck Mode.....	24
Figure 10-3	Ultra-High-Voltage Buck Mode.....	24
Figure 10-4	AC/DC Flyback Mode.....	24
Figure 10-5	Linear Regulators	25
Figure 10-6	Power Up Sequence	26
Figure 11-1	Configurable Analog Front End.....	33
Figure 12-1	Application Specific Power Drivers	43
Figure 12-2	Typical Gate Driver Connections	44
Figure 12-3	High-Side Switching Transients and Optional Circuitry	45
Figure 13-1	ADC with Auto-Sampling Sequencer	51
Figure 14-1	Memory System	53
Figure 15-1	Clock Control System.....	55
Figure 16-1	Arm Cortex-M0 Microcontroller Core	59
Figure 17-1	I/O controller	61
Figure 18-1	Serial Interface	64
Figure 18-2	I ² C Timing Diagram	68
Figure 18-3	SPI Timing Diagram	69
Figure 19-1	Timers A, B, C, and D	70
Figure 19-2	AFE Watchdog and Wake-Up Timer.....	71
Figure 19-3	Real-Time Clock and Watchdog Timer	71
Figure 21-1	3-Phase Motor Drive Using PAC5255 (Simplified Diagram).....	74
Figure 21-2	Solar Micro-Inverter Using PAC5255 (Simplified Diagram)	74
Figure 21-3	Motor with LED Lighting Using PAC5255 (Simplified Diagram).....	75
Figure 22-1	TQFN1010-57	76

1 GENERAL DESCRIPTION

The PAC5250 belongs to Active-Semi's broad portfolio of full-featured Power Application Controller® (PAC) products that are highly optimized for controlling and powering next generation smart energy appliances, devices, and equipment. These application controllers integrate a 50MHz Arm® Cortex®-M0 32-bit microcontroller core with Active-Semi's proprietary and patent-pending Multi-Mode Power Manager™, Configurable Analog Front End™, and Application Specific Power Drivers™ to form the most compact microcontroller-based power and general purpose application systems ranging from digital power supply to motor control. The PAC5250 microcontroller features up to 32kB of embedded FLASH and 8kB of SRAM memory, a high-speed 10-bit 1ms analog-to-digital converter (ADC) with dual auto-sampling sequencers, 5V/3.3V I/Os, flexible clock sources, timers, a versatile 14-channel PWM engine, and several serial interfaces.

The Multi-Mode Power Manager (MMPM) provides “all-in-one” efficient power management solution for multiple types of power sources. It features a configurable multi-mode switching supply controller capable of operating in buck, flyback, or boost mode, and up to four linear regulated voltage supplies. The Application Specific Power Drivers (ASPD) are high-voltage and ultra-high-voltage power drivers designed for each target set of control applications, including half bridge, H-bridge, 3-phase, intelligent power module (IPM), and general purpose driving. The Configurable Analog Front End (CAFE) comprises differential programmable gain amplifiers, single-ended programmable gain amplifiers, comparators, digital-to-analog converters, and I/Os for programmable and inter-connectible signal sampling, feedback amplification, and sensor monitoring of multiple analog input signals. Together, these modules and microcontroller enable a wide range of compact applications with highly integrated power management, driving, feedback, and control for DC supply up to 52V and for line AC supply.

Figure 1-1 Power Application Controller

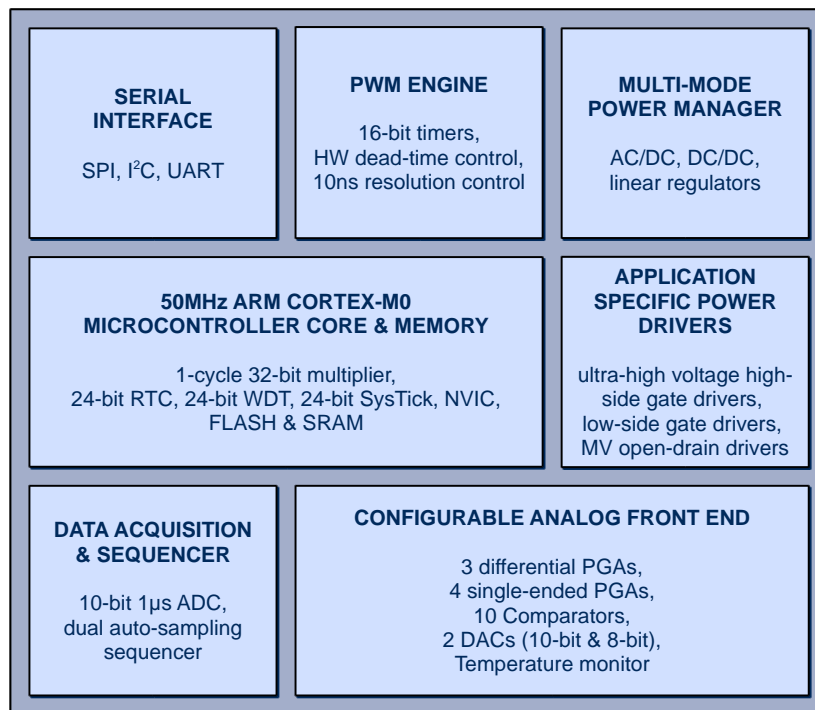

The PAC5250 is available in a 57-pin 10x10 TQFN package. The PAC family includes a range of part numbers optimized to work with different targeted primary applications.

2 PAC FAMILY APPLICATIONS

- Power Tools
- Garden Tools
- White Goods
- Embedded Speed Controllers
- Motor controllers

Figure 2-1 Simplified Application Diagram

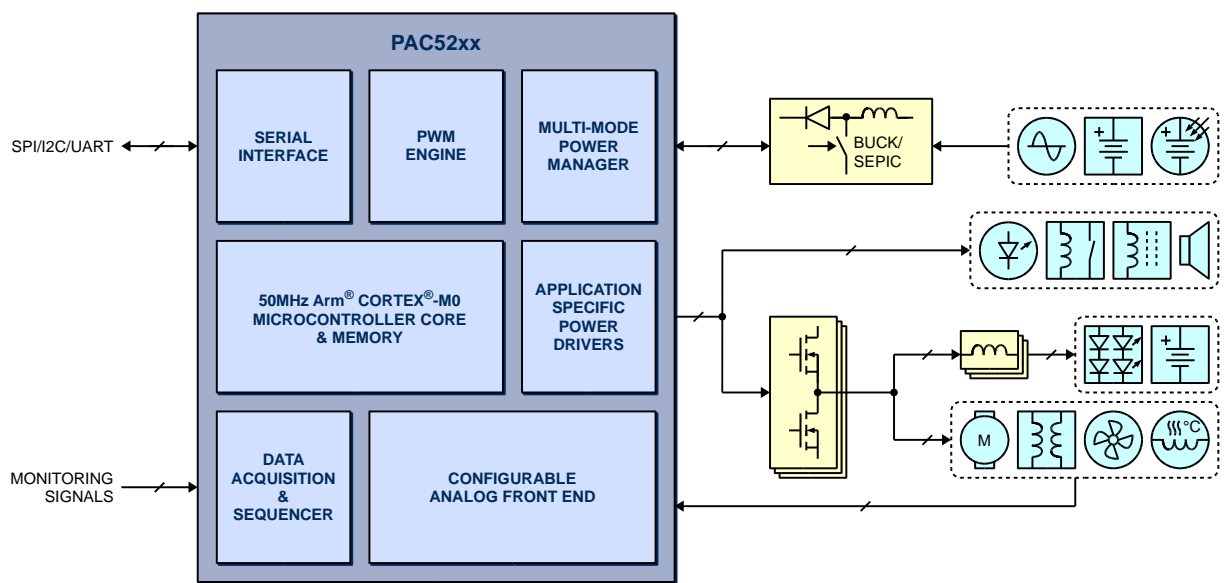

3 PRODUCT SELECTION SUMMARY

Table 3-1 Product Selection Summary

PART NUMBER	PIN PKG	POWER MANAGER		CONFIGURABLE ANALOG FRONT END					APPLICATION SPECIFIC POWER DRIVERS			MICROCONTROLLER					PRIMARY APPLICATION	
		INPUT VOLTAGE	MULTI-MODE SW	DIFF-PGA	PGA	COMPARATOR	DAC	ADC CHANNEL	POWER DRIVER	PWM CHANNEL	FAULT PROTECT	SPEED (MHz)	FLASH (kB)	SRAM (kB)	GPIO	INTERFACE		XTAL
PAC5250	57-pin 10x10 TQFN	5.2-52V	Y	3	4	10	2	9	6 LS (1A/1A) 3 HS (0.25A/ 0.5A) 2 OD (23V/ 40mA)	9	Int + Ext	50	32	8	25	SPI I ² C UART SWD	Y	UHV 3 half bridge, 3-phase control

Notes: DIFF-PGA = differential programmable gain amplifier, GD = gate driver, HS = high-side , LS = low-side, OD = open-drain driver, PGA = programmable gain amplifier, UHV = ultra-high-voltage.

4 ORDERING INFORMATION

Table 4-1 Ordering Information

PART NUMBER ⁽¹⁾	TEMPERATURE RANGE	PACKAGE	PINS	PACKING
PAC5250QF	-40°C to 105°C	TQFN1010-57	57 + Exposed Pad	Tray

⁽¹⁾ See Product Selection Summary for product features for each part number.

5 PAC5250 FEATURES

- Proprietary Multi-Mode Power Manager
 - ◆ Multi-mode switching supply controller configurable as high-voltage or ultra-high-voltage buck, AC/DC or flyback
 - ◆ DC supply up to 52V or line AC input
 - ◆ 4 linear regulators with power and hibernate management
 - ◆ Power and temperature monitor, warning, and fault detection
- Proprietary Configurable Analog Front End
 - ◆ 10 analog front end I/O pins
 - ◆ 3 differential programmable gain amplifiers
 - ◆ 4 single-ended programmable gain amplifiers
 - ◆ 10 comparators
 - ◆ 2 DACs (10-bit and 8-bit)
- Proprietary Application Specific Power Drivers
 - ◆ 6 low-side and 3 600V high-side gate drivers
 - ◆ 1A/1A low-side, 0.25A/0.5A high-side, gate driving capability
 - ◆ 2 23V/40mA open-drain drivers
 - ◆ Configurable delays and fast fault protection
- 50MHz Arm Cortex-M0 32-bit microcontroller core
 - ◆ Fast single cycle 32-bit x 32-bit multiplier
 - ◆ 24-bit SysTick timer
 - ◆ Nested vectored interrupt controller (NVIC) with 20 external interrupts
 - ◆ Wake-up interrupt controller allowing power-saving sleep modes
 - ◆ Clock-gating allowing low power operation
- 32kB FLASH and 8kB SRAM memory
- 10-bit 1 μ s ADC with multi-input/multi-sample control engine
 - ◆ 9 ADC inputs including input from configurable analog front end
- 3.3V I/Os
 - ◆ 2 general purpose I/Os with tri-state, and dedicated analog input to ADC
- True 5V I/Os
 - ◆ 13 general purpose I/Os with tri-state, pull-up and pull-down and dedicated I/O supply
 - ◆ Configurable between true 5V and 3.3V I/Os
- Flexible clock and PLL from internal 2% oscillator, ring oscillator, external clock, or crystal

- 9 timing generators
 - ◆ Four 16-bit timers with up to 16 PWM/CC blocks and 7 independent dead-time controllers
 - ◆ 24-bit watchdog timer
 - ◆ 4s or 8s watchdog timer
 - ◆ 24-bit real time clock
 - ◆ 24-bit SysTick timer
 - ◆ Wake-up timer for sleep modes from 0.125s to 8s
- SPI, I²C, and UART communication interfaces
- SWD debug interface with interface disable function

6 ABSOLUTE MAXIMUM RATINGS

Table 6-1 Absolute Maximum Ratings

(Do not exceed these limits to prevent damage to the device. Exposure to absolute maximum rating conditions for long periods may affect device reliability.)

PARAMETER		VALUE	UNIT
VHM, DRM to VSSP		-0.3 to 54	V
VP to VSS		-0.3 to 20	V
CSM, REGO to VSS		-0.3 to $V_P + 0.3$	V
VSYS, AIO6/.. to VSS		-0.3 to 6	V
VCC33 to VSS		-0.3 to 4.1	V
VCC18 to VSS		-0.3 to 2.5	V
AIOx/.. (except AIO6/..), VCCIO, CLKOUT/ENHS2 to VSS		-0.3 to $V_{SYS} + 0.3$	V
PDx/.., PEx/.. to VSS		-0.3 to $V_{CCIO} + 0.3$	V
XIN, XOUT to VSS		-0.3 to $V_{CC18} + 0.3$	V
PCx/.. to VSSA		-0.3 to $V_{CC33} + 0.3$	V
PAx/.., PBx/.., PCx/.., PDx/.., PEx/.. pin injection current		7.5	mA
PAx/.., PBx/.., PCx/.., PDx/.., PEx/.. sum of all pin injection current		25	mA
DRLx to VSSP		-0.3 to $V_P + 0.3$	V
DXBx to VSSP		-0.3 to 630	V
DXSx to VSSP		-11 to 610	V
DXSx allowable offset slew rate (dV_{DXSx}/dt)		-50 to 50	V/ns
DXBx, DXHx to respective DXSx		-0.3 to 22	V
OMx to VSSP		-0.3 to 24	V
VSSP, VSSA to VSS		-0.3 to 0.3	V
VSS, VSYS, DRM, DRLx, DXHx, REGO, OMx RMS current ⁽¹⁾		0.2	A _{RMS}
VSSP RMS current ⁽¹⁾		0.4	A _{RMS}
VP RMS current ⁽¹⁾		0.6	A _{RMS}
Operating temperature range		-40 to 105	°C
Electrostatic discharge (ESD)	Human body model (JEDEC)	2	kV
	Charge device model (JEDEC)	800	V
	Machine model (JEDEC)	200	V

⁽¹⁾ Peak current can be 10 times higher than RMS value for pulses shorter than 10 μ s.

7 ARCHITECTURAL BLOCK DIAGRAM

Figure 7-1 Architectural Block Diagram

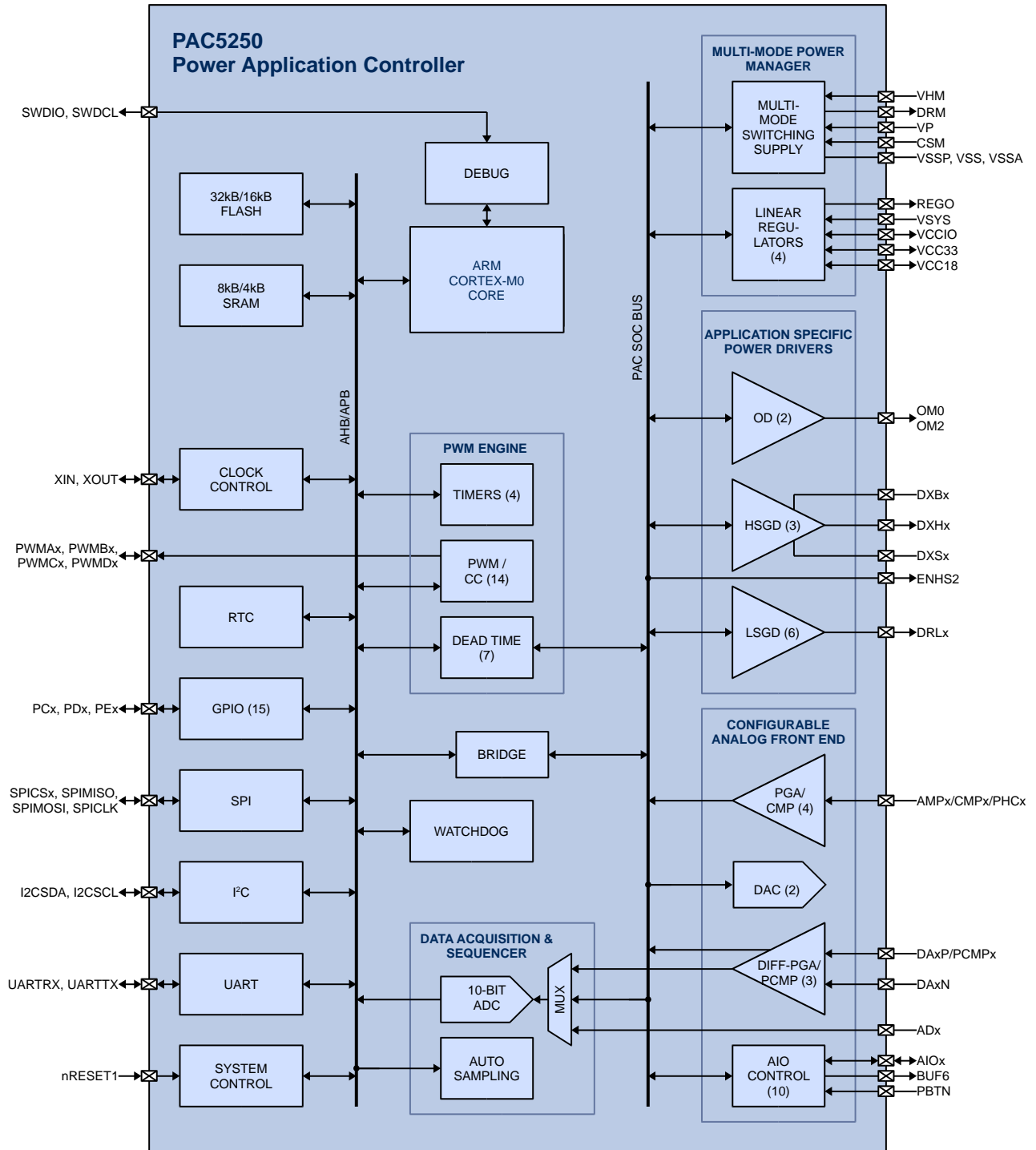

8 PIN CONFIGURATION

8.1 PAC5250QF

Figure 8-1 PAC5250QF Pin Configuration (TQFN1010-57 Package)

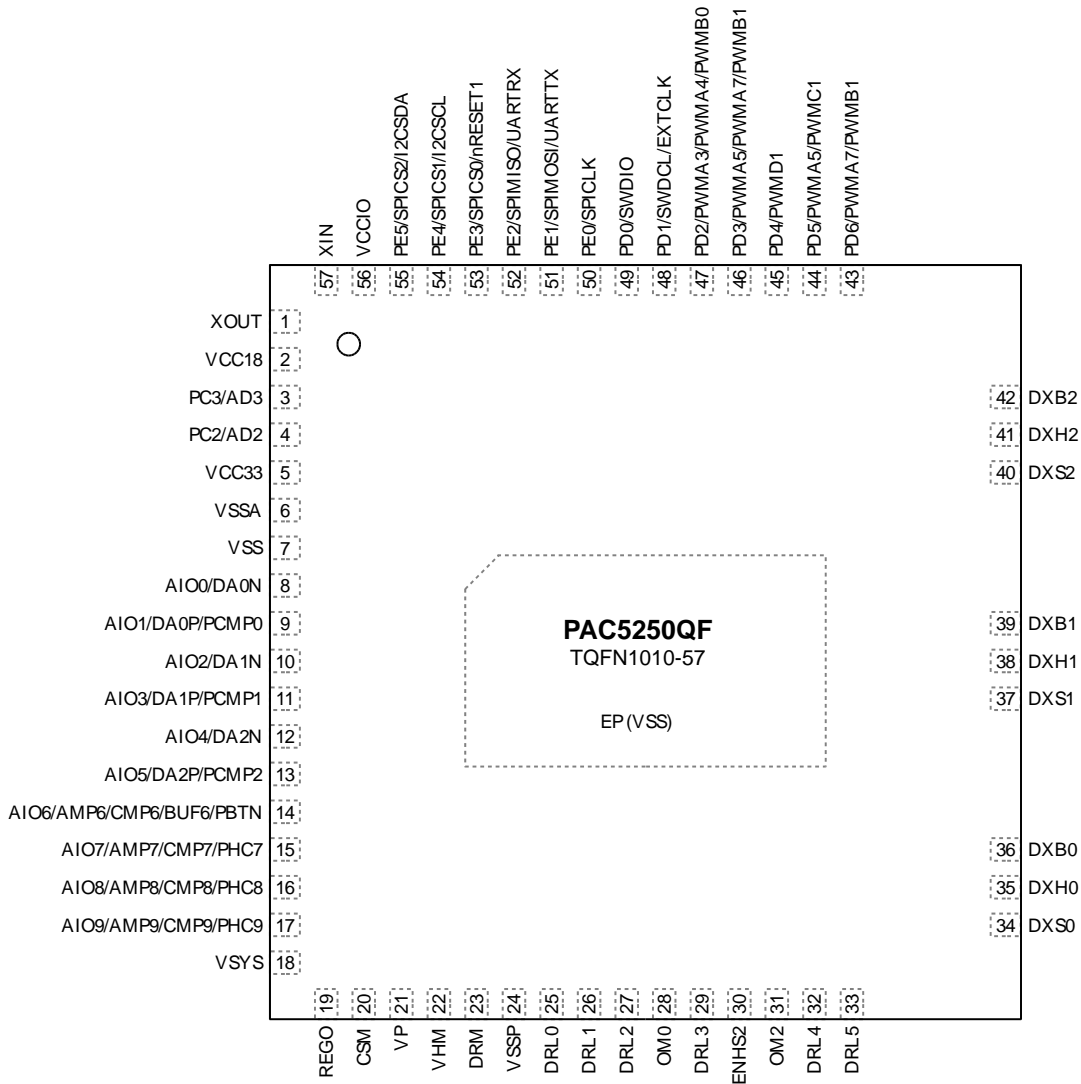

9 PIN DESCRIPTION

Table 9-1 Multi-Mode Power Manager and System Pin Description

PIN NAME	PIN NUMBER	TYPE	DESCRIPTION
CSM	20	Analog	Switching supply current sense input. Connect to the positive side of the current sense resistor.
DRM	23	Analog	Switching supply driver output. Connect to the base or gate of the external power NPN or n-channel MOSFET. See PAC User Guide and application notes.
EP (VSS)	EP	Power	Exposed pad. Must be connected to V_{SS} in a star ground configuration. Connect to a large PCB copper area for power dissipation heat sinking.
REGO	19	Power	System regulator output. Connect to V_{SYS} directly or through an external power-dissipating resistor.
VCC18	2	Power	Internally generated 1.8V core power supply. Connect a 2.2 μ F or higher value ceramic capacitor from V_{CC18} to V_{SSA} . See Figure 9-1. Power Supply Bypass Capacitor Routing below.
VCC33	5	Power	Internally generated 3.3V power supply. Connect a 2.2 μ F or higher value ceramic capacitor from V_{CC33} to V_{SSA} . See PCB layout note below.
VCCIO	56	Power	Internally generated digital I/O power supply. Connect a 4.7 μ F or higher value ceramic capacitor from V_{CCIO} to V_{SSA} . See Figure 9-1. Power Supply Bypass Capacitor Routing below.
VHM	22	Power	Switching supply controller supply input. Connect a 1 μ F or higher value ceramic capacitor, or a 0.1 μ F ceramic capacitor in parallel with a 10 μ F or higher electrolytic capacitor from V_{HM} to V_{SSP} . This pin requires good capacitive bypassing to V_{SSP} , so the ceramic capacitor must be connected with a shorter than 10mm trace from the pin. See Figure 9-1. Power Supply Bypass Capacitor Routing below.
VP	21	Power	Main power supply. Provides power to the power drivers as well as voltage feedback path for the switching supply. Connect a properly sized supply bypass capacitor in parallel with a 0.1 μ F ceramic capacitor from V_P pin to V_{SS} for voltage loop stabilization. This pin requires good capacitive bypassing to V_{SS} , so the ceramic capacitor must be connected with a shorter than 10mm trace from the pin. See Figure 9-1. Power Supply Bypass Capacitor Routing below.
VSS	7	Power	Ground.
VSSA	6	Power	Analog ground. Connect to V_{SS} in a star ground configuration.
VSSP	24	Power	Power ground. Connect to V_{SS} in a star ground configuration.
VSYS	18	Power	5V system power supply. Connect a 4.7 μ F or higher value ceramic capacitor from V_{SYS} to V_{SSP} . See Figure 9-1. Power Supply Bypass Capacitor Routing below.
XIN	57	Analog	Crystal oscillator driver input. Leave floating if unused.
XOUT	1	Analog	Crystal oscillator driver output. Leave floating if unused.

Table 9-2 Configurable Analog Front End Pin Description

PIN NAME	PIN NUMBER	FUNCTION	TYPE	DESCRIPTION
AIO0/DA0N	8	AIO0	I/O	Analog front end I/O 0.
		DA0N	Analog	Differential PGA 0 negative input.
AIO1/DA0P/PCMP0	9	AIO1	I/O	Analog front end I/O 1.
		DA0P	Analog	Differential PGA 0 positive input.
		PCMP0	Analog	Protection comparator input 0.
AIO2/DA1N	10	AIO2	I/O	Analog front end I/O 2.
		DA1N	Analog	Differential PGA 1 negative input.
AIO3/DA1P/PCMP1	11	AIO3	I/O	Analog front end I/O 3.
		DA1P	Analog	Differential PGA 1 positive input.
		PCMP1	Analog	Protection comparator input 1.
AIO4/DA2N	12	AIO4	I/O	Analog front end I/O 4.
		DA2N	Analog	Differential PGA 2 negative input.
AIO5/DA2P/PCMP2	13	AIO5	I/O	Analog front end I/O 5.
		DA2P	Analog	Differential PGA 2 positive input.
		PCMP2	Analog	Protection comparator input 2.
AIO6/AMP6/CMP6/BUF6/PBTN	14	AIO6	I/O	Analog front end I/O 6.
		AMP6	Analog	PGA input 6.
		CMP6	Analog	Comparator input 6.
		BUF6	Analog	Buffer output 6.
		PBTN	Analog	Push button input.
AIO7/AMP7/CMP7/PHC7	15	AIO7	I/O	Analog front end I/O 7.
		AMP7	Analog	PGA input 7.
		CMP7	Analog	Comparator input 7.
		PHC7	Analog	Phase comparator input 7.
AIO8/AMP8/CMP8/PHC8	16	AIO8	I/O	Analog front end I/O 8.
		AMP8	Analog	PGA input 8.
		CMP8	Analog	Comparator input 8.
		PHC8	Analog	Phase comparator input 8.
AIO9/AMP9/CMP9/PHC9	17	AIO9	I/O	Analog front end I/O 9.
		AMP9	Analog	PGA input 9.
		CMP9	Analog	Comparator input 9.
		PHC9	Analog	Phase comparator input 9.

Table 9-3 Application Specific Power Drivers Pin Description

PIN NAME	PIN NUMBER	TYPE	DESCRIPTION
DRL0	25	Analog	Low-side gate driver 0.
DRL1	26	Analog	Low-side gate driver 1.
DRL2	27	Analog	Low-side gate driver 2.
DRL3	29	Analog	Low-side gate driver 3.
DRL4	32	Analog	Low-side gate driver 4.
DRL5	33	Analog	Low-side gate driver 5.
DXB0	36	Analog	Ultra-high-voltage high-side gate driver bootstrap 0.
DXB1	39	Analog	Ultra-high-voltage high-side gate driver bootstrap 1.
DXB2	42	Analog	Ultra-high-voltage high-side gate driver bootstrap 2.
DXH0	35	Analog	Ultra-high-voltage high-side gate driver 0.
DXH1	38	Analog	Ultra-high-voltage high-side gate driver 1.
DXH2	41	Analog	Ultra-high-voltage high-side gate driver 2.
DXS0	34	Analog	Ultra-high-voltage high-side gate driver source 0.
DXS1	37	Analog	Ultra-high-voltage high-side gate driver source 1.
DXS2	40	Analog	Ultra-high-voltage high-side gate driver source 2.
ENHS2	30	O	High-side driver group 2 control enable output.
OM0	28	OD	Medium-voltage open-drain driver 0.
OM2	31	OD	Medium-voltage open-drain driver 2.

Table 9-4 I/O Ports Pin Description

PIN NAME	PIN NUMBER	FUNCTION	TYPE	DESCRIPTION
PC2/AD2	4	PC2	I/O	I/O port C2.
		AD2	Analog	ADC input 2.
PC3/AD3	3	PC3	I/O	I/O port C3.
		AD3	Analog	ADC input 3.
PD0/SWDIO	49	PD0	I/O	I/O port D0.
		SWDIO	I/O	Serial wire debug I/O.
PD1/SWDCL/EXTCLK	48	PD1	I/O	I/O port D1.
		SWDCL	I	Serial wire debug clock.
		EXTCLK	I	External clock.
PD2/PWMA3/PWMA4/PWMB0	47	PD2	I/O	I/O port D2.
		PWMA3	I/O	Timer A PWM/capture 3.
		PWMA4	I/O	Timer A PWM/capture 4.
		PWMB0	I/O	Timer B PWM/capture 0.
PD3/PWMA5/PWMA7/PWMB1	46	PD3	I/O	I/O port D3.
		PWMA5	I/O	Timer A PWM/capture 5.
		PWMA7	I/O	Timer A PWM/capture 7.
		PWMB1	I/O	Timer B PWM/capture 1.
PD4/PWMD1	45	PD4	I/O	I/O port D4.
		PWMD1	I/O	Timer D PWM/capture 1.
PD5/PWMA5/PWMC1	44	PD5	I/O	I/O port D5.
		PWMA5	I/O	Timer A PWM/capture 5.
		PWMC1	I/O	Timer C PWM/capture 1.
PD6/PWMA7/PWMB1	43	PD6	I/O	I/O port D6.
		PWMA7	I/O	Timer A PWM/capture 7.
		PWMB1	I/O	Timer B PWM/capture 1.
PE0/SPICLK	50	PE0	I/O	I/O port E0.
		SPICLK	I/O	SPI clock.
PE1/SPIMOSI/UARTTX	51	PE1	I/O	I/O port E1.
		SPIMOSI	I/O	SPI master out slave in (MOSI).
		UARTTX	O	UART transmit output.
PE2/SPIMISO/UARTRX	52	PE2	I/O	I/O port E2.
		SPIMISO	I/O	SPI master in slave out (MISO).
		UARTRX	I	UART receive input.

Table 9-5 I/O Ports Pin Description (Continued)

PIN NAME	PIN NUMBER	FUNCTION	TYPE	DESCRIPTION
PE3/SPICS0/nRESET1	53	PE3	I/O	I/O port E3.
		SPICS0	O	SPI chip select 0.
		nRESET1	I	Reset input 1 (active low).
PE4/SPICS1/I2CSCL	54	PE4	I/O	I/O port E4.
		SPICS1	O	SPI chip select 1.
		I2CSCL	I/O	I2C clock.
PE5/SPICS2/I2CSDA	55	PE5	I/O	I/O port E5.
		SPICS2	O	SPI chip select 2.
		I2CSDA	I/O	I2C data.

Figure 9-1 Power Supply Bypass Capacitor Routing

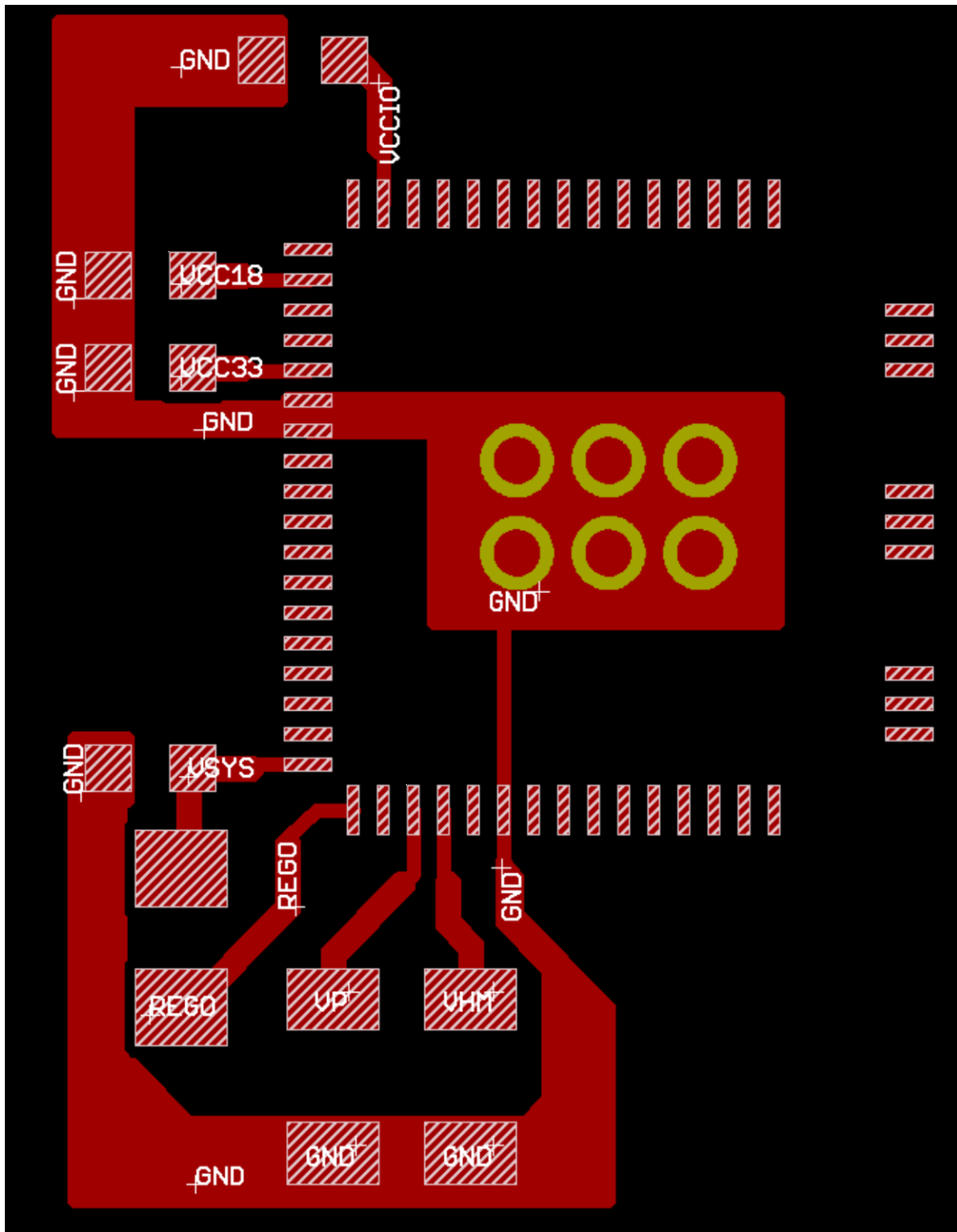

10 MULTI-MODE POWER MANAGER (MMPM)

10.1 Features

- Multi-mode switching supply controller configurable as high voltage or ultra-high-voltage buck, flyback AC/DC
- DC supply up to 52V or line AC input
- 4 linear regulators with power and hibernate management
- Power and temperature monitor, warning, and fault detection

10.2 Block Diagram

Figure 10-1 Multi-Mode Power Manager

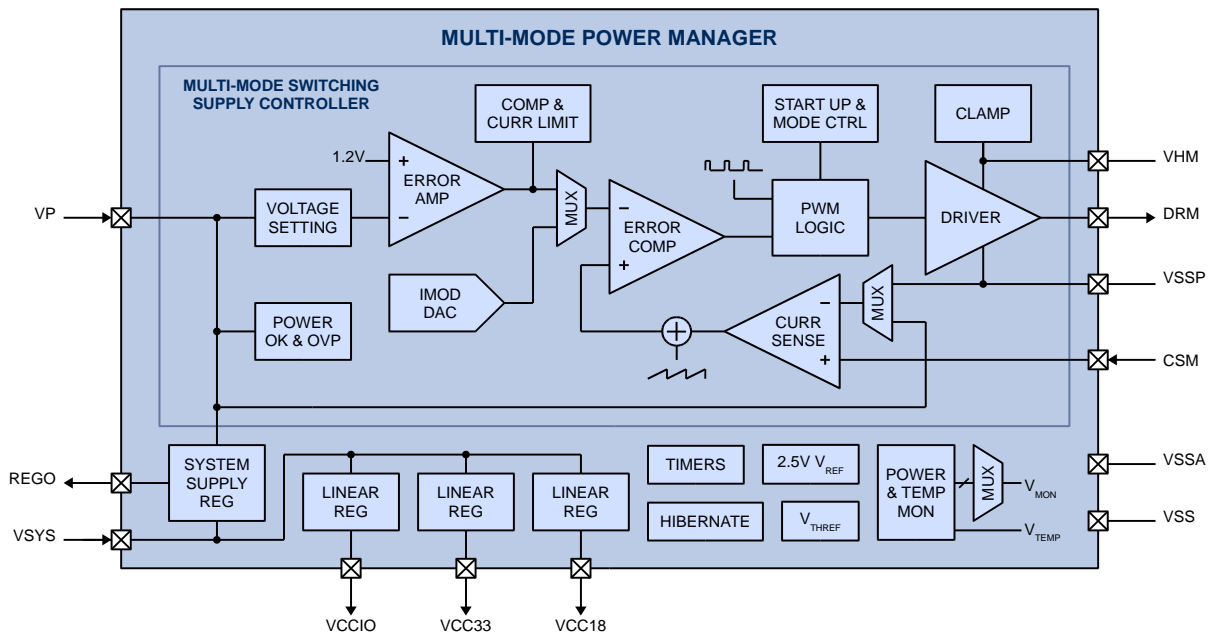

10.3 Functional Description

The Multi-Mode Power Manager ([Figure 10-1](#)) is optimized to efficiently provide "all-in-one" power management required by the PAC and associated application circuitry from a wide range of input power sources. It incorporates a dedicated multi-mode switching supply (MMSS) controller operable as a buck, flyback, or boost converter to efficiently convert power from a DC or AC input source to generate a main supply output V_P . Four linear regulators provide V_{SYS} , V_{CCIO} , V_{CC33} , and V_{CC18} supplies for 5V system, 5V or 3.3V I/O, 3.3V mixed signal, and 1.8V microcontroller core circuitry. The power manager also handles system functions including internal reference generation, timers, hibernate mode management, and power and temperature monitoring.

10.3.1 Multi-Mode Switching Supply (MMSS) Controller

The MMSS controller drives an external power transistor for pulse-width modulation switching of an inductor or transformer for power conversion. The DRM output drives the gate of the n-channel MOSFET or the base of the NPN between the V_{HM} on state and V_{SSP} off state at proper duty cycle and switching frequency to ensure that the main supply voltage V_P is regulated. The V_P regulation voltage is initially set to 12V during start up, and can be reconfigured to be 5V, 9V, or 15V by the microcontroller after initialization¹. When V_P is lower than the target regulation voltage, the internal feedback control circuitry causes the inductor current to increase to raise V_P . Conversely, when V_P is higher than the regulation voltage, the feedback loop control causes the inductor current to decrease to lower V_P . The feedback loop is internally stabilized. The output current capability of the switching supply is determined by the external current sense resistor. In the high-side current sense buck mode, the inductor current signal is sensed differentially between the CSM pin and V_P , and has a peak current limit threshold of 0.26V. In the low-side current sense flyback or boost mode, the inductor current signal is sensed differentially between the CSM pin and V_{SSP} , and has a peak current limit threshold of 1V.

The MMSS controller is flexible and configurable as a buck, flyback, or boost converter. Input sources include battery supply for buck mode ([Figure 10-2](#)), and AC line supply voltage range for ultra-high-voltage buck mode ([Figure 10-3](#)), AC/DC flyback mode ([Figure 10-4](#)). The MMSS controller operational mode is determined by external configuration and register setting from the microcontroller after power up. It can operate in either high-side or low-side current sense mode, and does not require external feedback loop compensation circuitry. For optional extended application range, the MMSS also incorporates additional digital control by the microcontroller to add accurate computations for outer feedback loop control such as power factor correction and accurate current control.

¹ Note that on any device with ultra-high voltage drivers (PAC525X), it is invalid to set V_P to less than 12V.

Figure 10-2 Buck Mode

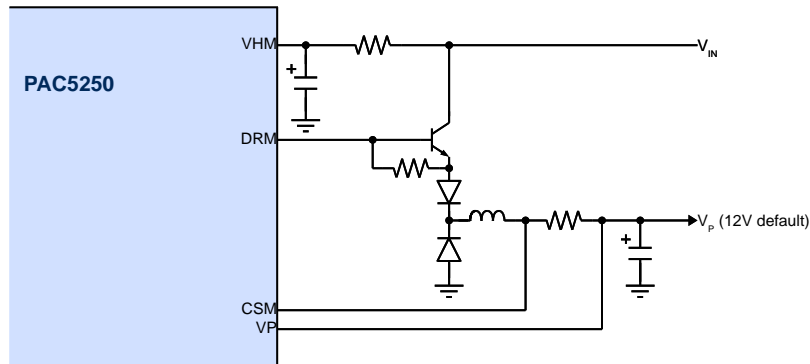

Figure 10-3 Ultra-High-Voltage Buck Mode

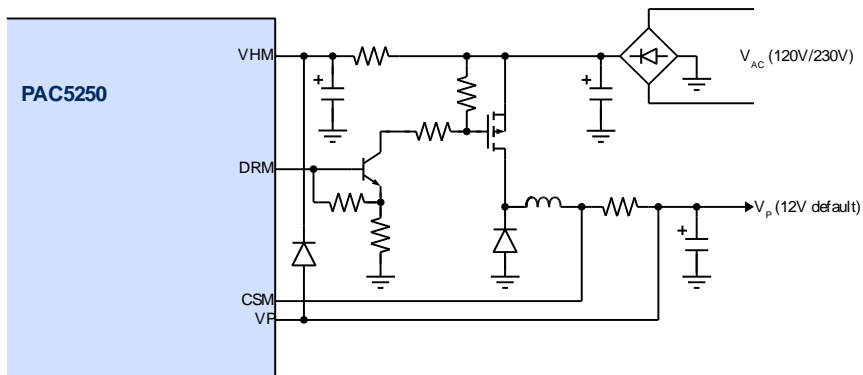
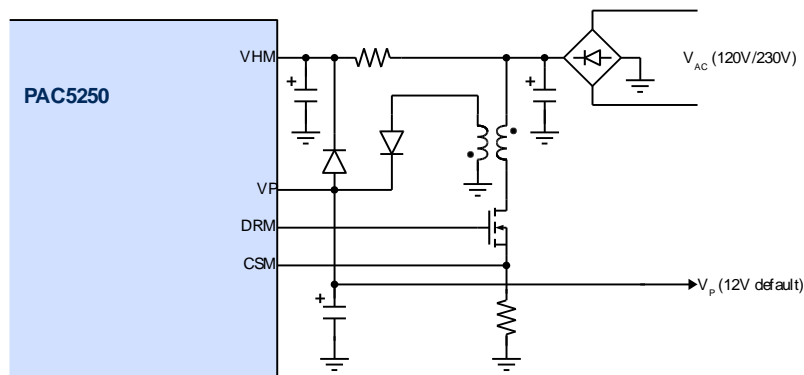

Figure 10-4 AC/DC Flyback Mode



The MMSS detects and selects between high-side and low-side mode during start up based on the placement of the current sense resistor and the CSM pin voltage. It employs a safe start up mode with 9.5kHz switching frequency until V_P exceeds 4.3V under-voltage-lockout threshold, then transitions to the 45kHz default switching frequency for at least 6ms to bring V_P close to the target voltage, before enabling the linear regulators. Any extra load should only be applied after the supplies are available and the microprocessor has initialized. The switching frequency can be reconfigured by the microprocessor to be 181kHz to 500kHz in the high switching frequency mode for battery-based applications, and to be 45kHz to 125kHz in the low switching frequency mode for AC applications. Upon initialization, the microcontroller must reconfigure the MMSS to the desired settings for V_P regulation voltage, switching mode, switching frequency, and V_{HM} clamp. Refer to the PAC application notes and user guide for MMSS controller design and programming.

If a stable external 4.5V to 18V power source is available, it can power the V_P main supply and all the linear regulators directly without requiring the MMSS controller to operate. In such applications, V_{HM} can be connected directly to V_P and the microcontroller should disable the MMSS upon initialization to reduce power loss.

10.3.2 Linear Regulators

The MMPM includes up to four linear regulators. The system supply regulator is a medium voltage regulator that takes the V_P supply and sources up to 200mA at REGO until V_{SYS} , externally coupled to REGO, reaches 5V. This allows a properly rated external resistor to be connected from REGO to V_{SYS} to close the current loop and offload power dissipation between V_P and V_{SYS} . Once V_{SYS} is above 4V, the three additional 40mA linear regulators for V_{CCIO} , V_{CC33} , and V_{CC18} supplies sequentially power up. [Figure 10-5](#) shows typical circuit connections for the linear regulators. For 5V I/O systems, short the V_{CCIO} pin to V_{SYS} to bypass the V_{CCIO} regulator. For 3.3V I/O systems, the V_{CCIO} regulator generates 3.3V. The V_{CC33} and V_{CC18} regulators generate 3.3V and 1.8V, respectively. When V_{SYS} , V_{CCIO} , V_{CC33} , and V_{CC18} are all above their respective power good threshold, and the configurable power on reset duration has expired, the microcontroller is initialized.

Figure 10-5 Linear Regulators

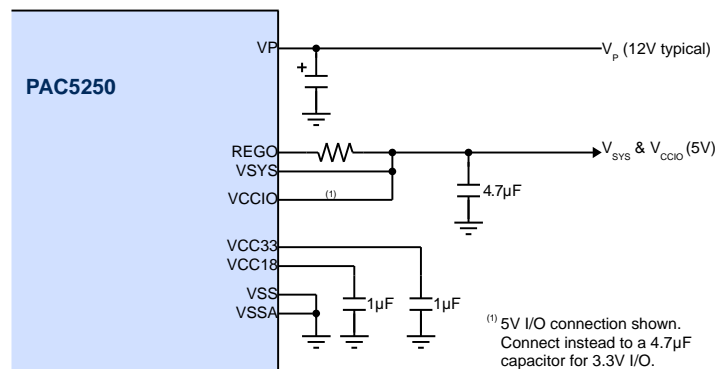

10.3.3 Power Up Sequence

The MMPM follows a typical power up sequence as in the [Figure 10-6](#) below. A typical sequence begins with input power supply being applied, followed by the safe start up and start up durations to bring the switching supply output V_P to 12V, before the linear regulators are enabled. When all the supplies are ready, the internal clocks become available, and the microcontroller starts executing from the program memory. During initialization, the microcontroller can reconfigure the switching supply to a different V_P regulation voltage such as 15V and to an appropriate switching frequency and switching mode. The total loading on the switching supply must be kept below 25% of the maximum output current until after the reconfiguration of the switching supply is complete. For AC input supply applications, the start up sequence includes an additional charging time for V_{HM} depending on the start-up resistor and capacitor values.

Figure 10-6 Power Up Sequence

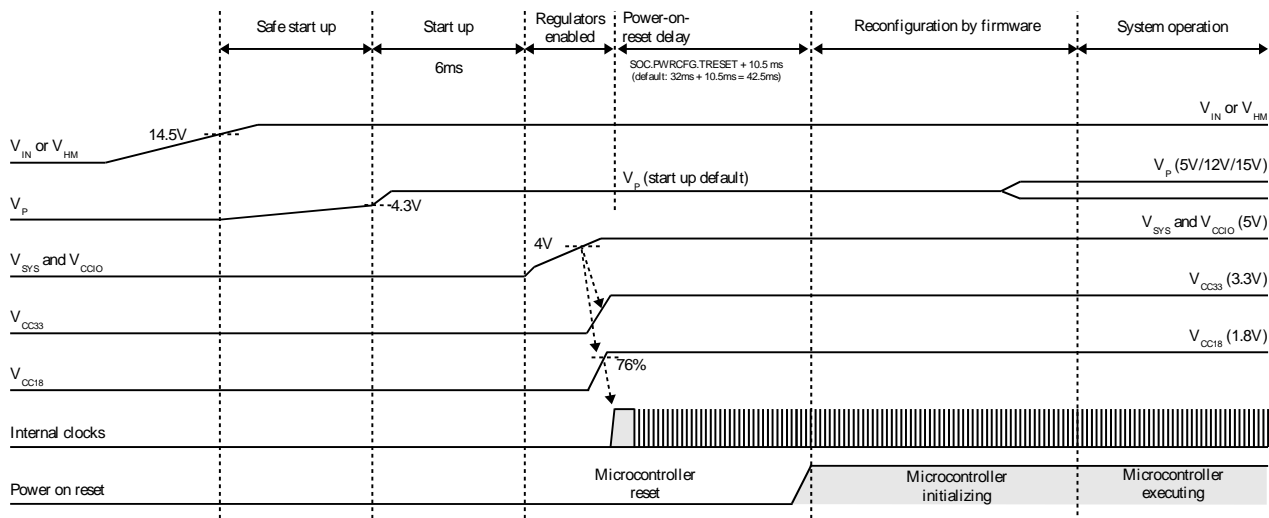

10.3.4 Hibernate Mode

The IC can go into an ultra-low power hibernate mode via the microcontroller firmware or via the optional push button (PBTN, see Push Button description in Configurable Analog Front End). In hibernate mode, only a minimal amount (typically 18 μ A) of current is used by V_{HM} , and the MMSS controller and all internal regulators are shut down to eliminate power drain from the output supplies. The system exits hibernate mode after a wake-up timer duration (configurable from 125ms to 8s or infinite) has expired or, if push button enabled, after an additional push button event has been detected. When exiting the hibernate mode, the power manager goes through the start up cycle and the microcontroller is reinitialized. Only the persistent power manager status bits (resets and faults) are retained during hibernation.

10.3.5 Power and Temperature Monitor

Whenever any of the V_{SYS} , V_{CCIO} , V_{CC33} , or V_{CC18} power supplies falls below their respective power good threshold voltage, a fault event is detected and the microcontroller is reset. The microcontroller stays in the reset state until V_{SYS} , V_{CCIO} , V_{CC33} , and V_{CC18} supply rails are all good again and the reset time has expired. A microcontroller reset can also be initiated by a maskable temperature fault event that occurs when the IC temperature reaches 170°C. The fault status bits are persistent during reset, and can be read by the microcontroller upon re-initialization to determine the cause of previous reset.

A power monitoring signal V_{MON} is provided onto the ADC pre-multiplexer for monitoring various internal power supplies. V_{MON} can be set to be V_{CC18} , $0.4 \cdot V_{CC33}$, $0.4 \cdot V_{CCIO}$, $0.4 \cdot V_{SYS}$, $0.1 \cdot V_{REGO}$, $0.1 \cdot V_P$, $0.0333 \cdot V_{HM}$, or the internal compensation voltage V_{COMP} for switching supply power monitoring.

For power and temperature warning, a V_P low event at 77% of the regulation voltage and an IC temperature warning event at 140°C are provided as maskable interrupts to the microcontroller. These warnings allow the microcontroller to safely power down the system.

In addition to the temperature warning interrupt and fault reset, a temperature monitor signal $V_{TEMP} = 1.5 + 5.04e-3 \cdot (T - 25^\circ\text{C})$ (V) is provided onto the ADC pre-multiplexer for IC temperature measurement.

10.3.6 Voltage Reference

The reference block includes a 2.5V high precision reference voltage that provides the 2.5V reference voltage for the ADC, the DACs, and the 4-level programmable threshold voltage V_{THREF} (0.1V, 0.2V, 0.5V, and 1.25V).

10.4 Electrical Characteristics

Table 10-1 Multi-Mode Switching Supply Controller Electrical Characteristics

($V_{HM} = 24V$, $V_P = 12V$, and $T_A = -40^{\circ}C$ to $105^{\circ}C$ unless otherwise specified.)

SYMBOL	PARAMETER	CONDITIONS	MIN	TYP	MAX	UNIT
Input Supply (V_{HM})						
$I_{HIB;VHM}$	V_{HM} hibernate mode supply current	V_{HM} , hibernate mode		18	36	μA
$I_{SU;VHM}$	V_{HM} start up supply current	$V_{HM} < V_{UVLOR;VHM}$		75	120	μA
$I_{OP;VHM}$	V_{HM} operating supply current	DRM floating		0.3	0.5	mA
$V_{OP;VHM}$	V_{HM} operating voltage range		5.2		52	V
$V_{UVLOR;VHM}$	V_{HM} under-voltage lockout rising		13.5	14.5	16	V
$V_{UVLOF;VHM}$	V_{HM} under-voltage lockout falling		6.8	7.5	8.1	V
$V_{CLAMP;VHM}$	V_{HM} clamp voltage	Clamp enabled, sink current = $100\mu A$		23	26.6	V
$I_{CLAMP;VHM}$	V_{HM} clamp sink current limit	Clamp enabled	0.72	1.2		mA
Output Supply and Feedback (V_P)						
$V_{REG;VP}$	V_P output regulation voltage	Programmable to 5V, 9V, 12V, or 15V Load = 0 to 500mA	-7	-1	5	%
$K_{POK;VP}$	V_P power OK threshold	V_P rising, hysteresis = 10%	82	87	92	%
$K_{OVP;VP}$	V_P over voltage protection threshold	V_P rising, hysteresis = 15% MMPM Controller Enabled		136		%
Switching Control						
$f_{SWMACC;DRM}$	Switching frequency accuracy		-10		10	%
$f_{SWM;DRM}$	Switching frequency programmable range	High frequency mode, 8 settings	181		500	kHz
		Low frequency mode, 8 settings	45		125	
$f_{SSU;DRM}$	Safe start up switching frequency			9.5		kHz
$t_{ONMIN;DRM}$	Minimum on time			440		ns
$t_{OFFMIN;DRM}$	Minimum off time	Low duty-cycle & Low-frequency mode		25		%
		Low duty-cycle & High-frequency mode		440		ns
		High duty-cycle mode		820		ns

SYMBOL	PARAMETER	CONDITIONS	MIN	TYP	MAX	UNIT
Current Sense (CSM Pin)						
$V_{DET;CSM}$	CSM mode detection threshold	Rising, hysteresis = 50mV	0.40	0.55	0.69	V
$V_{HSLIM;CSM}$	High-side current limit threshold	181kHz, duty = 25%, relative to VP	0.17	0.26	0.35	V
$V_{LSLIM;CSM}$	Low-side current limit threshold	45kHz, duty = 25%	0.7	1	1.48	V
$t_{BLANK;CSM}$	Current sense blanking time			200		ns
$V_{PROT;CSM}$	Low-side abnormal current sense protection threshold	$V_P < 4.3V$		0.8		V
		$V_P > 4.3V$		1.9		
Gate Driver Output (DRM Pin)						
$V_{OH;DRM}$	High-level output voltage	$I_{DRM} = -20mA$	$V_{HM} - 1.4$			V
$V_{OL;DRM}$	Low-level output voltage	$I_{DRM} = 20mA$	0.6			V
$I_{OH;DRM}$	High-level output source current	$V_{DRM} = V_{HM} - 5V$	-0.1			A
$I_{OL;DRM}$	Low-level output sink current	$V_{DRM} = 5V$	0.25			A
$t_{PD;DRM}$	Strong pull down pulse width	High-side current sense mode	240			ns

Table 10-2 Linear Regulators Electrical Characteristics

($V_P = 12V$ and $T_A = -40^\circ C$ to $105^\circ C$ unless otherwise specified.)

SYMBOL	PARAMETER	CONDITIONS	MIN	TYP	MAX	UNIT
$V_{OP;VP}$	V_P operating voltage range		4.5		18	V
$V_{UVLO;VP}$	V_P under-voltage-lockout threshold	V_P rising, hysteresis = 0.2V	4	4.3	4.5	V
$I_{Q;VP}$	V_P quiescent supply current	Power manager only, including $I_{Q;V_{SYS}}$		400	750	μA
$I_{Q;V_{SYS}}$	V_{SYS} quiescent supply current	V_{CCIO} , V_{CC33} , and V_{CC18} regulators only		350	600	μA
V_{SYS}	V_{SYS} output voltage	Load = 10 μA to 200mA	4.8	5	5.18	V
V_{CCIO}	V_{CCIO} output voltage	Load = 10mA	V_{CCIO} shorted to V_{SYS}			V
			3.152	3.3	3.398	
V_{CC33}	V_{CC33} output voltage	Load = 10mA	3.185	3.3	3.415	V
V_{CC18}	V_{CC18} output voltage	Load = 10mA	1.834	1.9	1.979	V
$I_{LIM;V_{SYS}}$	V_{SYS} regulator current limit		220	330		mA
$I_{LIM;V_{CCIO}}$	V_{CCIO} regulator current limit		45	80		mA
$I_{LIM;V_{CC33}}$	V_{CC33} regulator current limit		45	80		mA
$I_{LIM;V_{CC18}}$	V_{CC18} regulator current limit		45	80		mA
k_{SCFB}	Short circuit current fold back			50		%
$V_{DO;V_{SYS}}$	V_{SYS} dropout voltage	$V_P=5V$, $I_{SYS}=100mA$		350	680	mV
$V_{UVLO;V_{SYS}}$	V_{SYS} under-voltage-lockout threshold	V_{SYS} rising, hysteresis = 0.2V	3.5	4	4.4	V
k_{POKIO}	V_{CCIO} Power OK threshold	V_{CCIO} rising, hysteresis = 10%	75	82	89	%
k_{POK33}	V_{CC33} Power OK threshold	V_{CC33} rising, hysteresis = 10%	71	78	85	%
k_{POK18}	V_{CC18} Power OK threshold	V_{CC18} falling, hysteresis = 10%	58	66	74	%

Table 10-3 Power System Electrical Characteristics

($V_{SYS} = V_{CCIO} = 5V$, $V_{CC33} = 3.3V$, and $T_A = -40^{\circ}C$ to $105^{\circ}C$ unless otherwise specified.)

SYMBOL	PARAMETER	CONDITIONS	MIN	TYP	MAX	UNIT
V _{REF}	Reference voltage	T _A = 25°C	2.487	2.5	2.513	V
		T _A = -40°C to 105°C	2.463	2.5	2.537	
k _{MON}	Power monitoring voltage (V _{MON}) coefficient	V _{CC18}	0.92	1	1.02	V/V
		V _{SYS} , V _{CCIO} , V _{CC33}	0.36	0.4	0.43	
		V _P , V _{REGO}	0.09	0.1	0.11	
		V _{HM}	0.03	0.0333	0.038	
V _{TEMP}	Temperature monitor voltage at 25°C	T _A = 25°C, at ADC	1.475	1.5	1.540	V
k _{TEMP}	Temperature monitor coefficient	At ADC		5.04		mV/K
T _{WARN}	Over-temperature warning threshold	Hysteresis = 10°C		140		°C
T _{FAULT}	Over-temperature fault threshold	Hysteresis = 10°C		170		°C

10.5 Typical Performance Characteristics

($V_P = 12V$ and $T_A = 25^\circ C$ unless otherwise specified.)

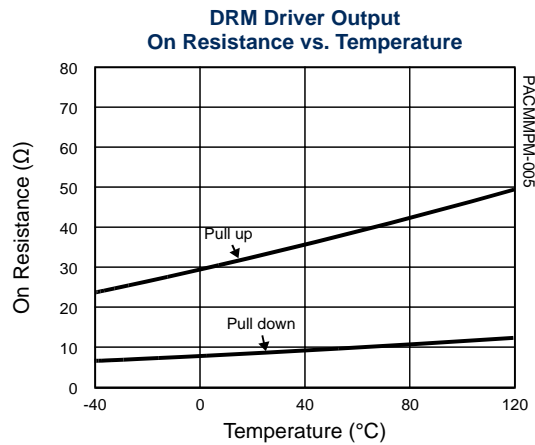
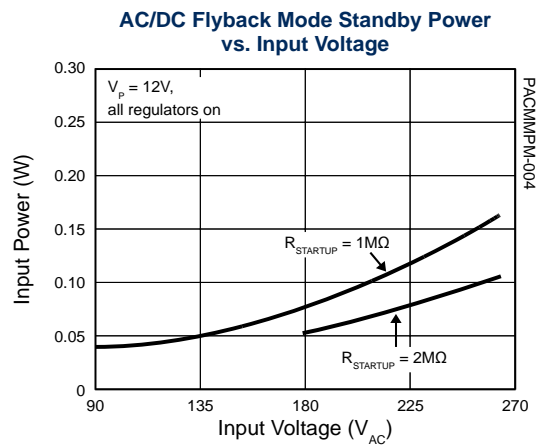
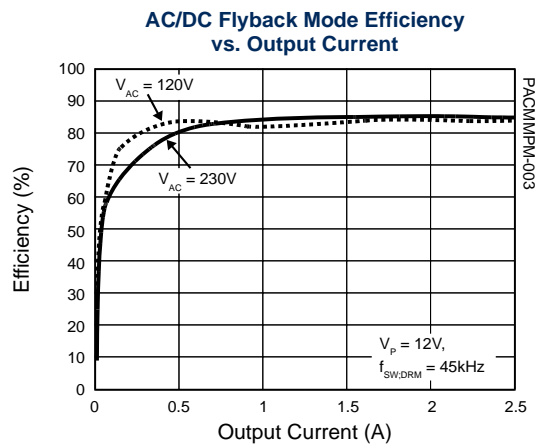
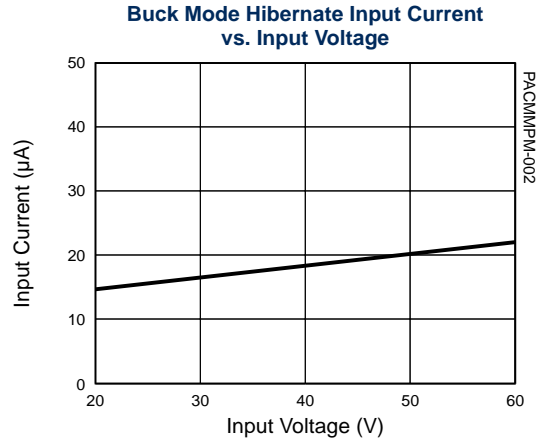
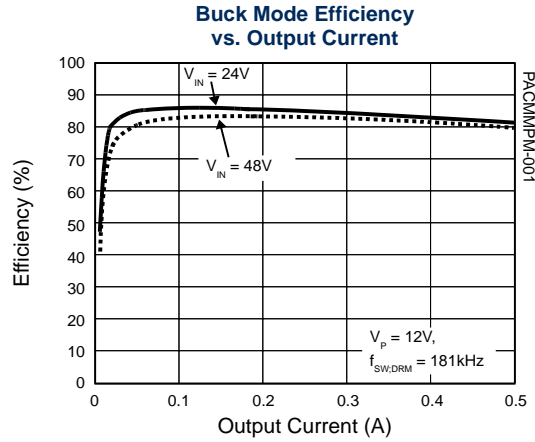

11 CONFIGURABLE ANALOG FRONT END (CAFE)

11.1 Block Diagram

Figure 11-1 Configurable Analog Front End

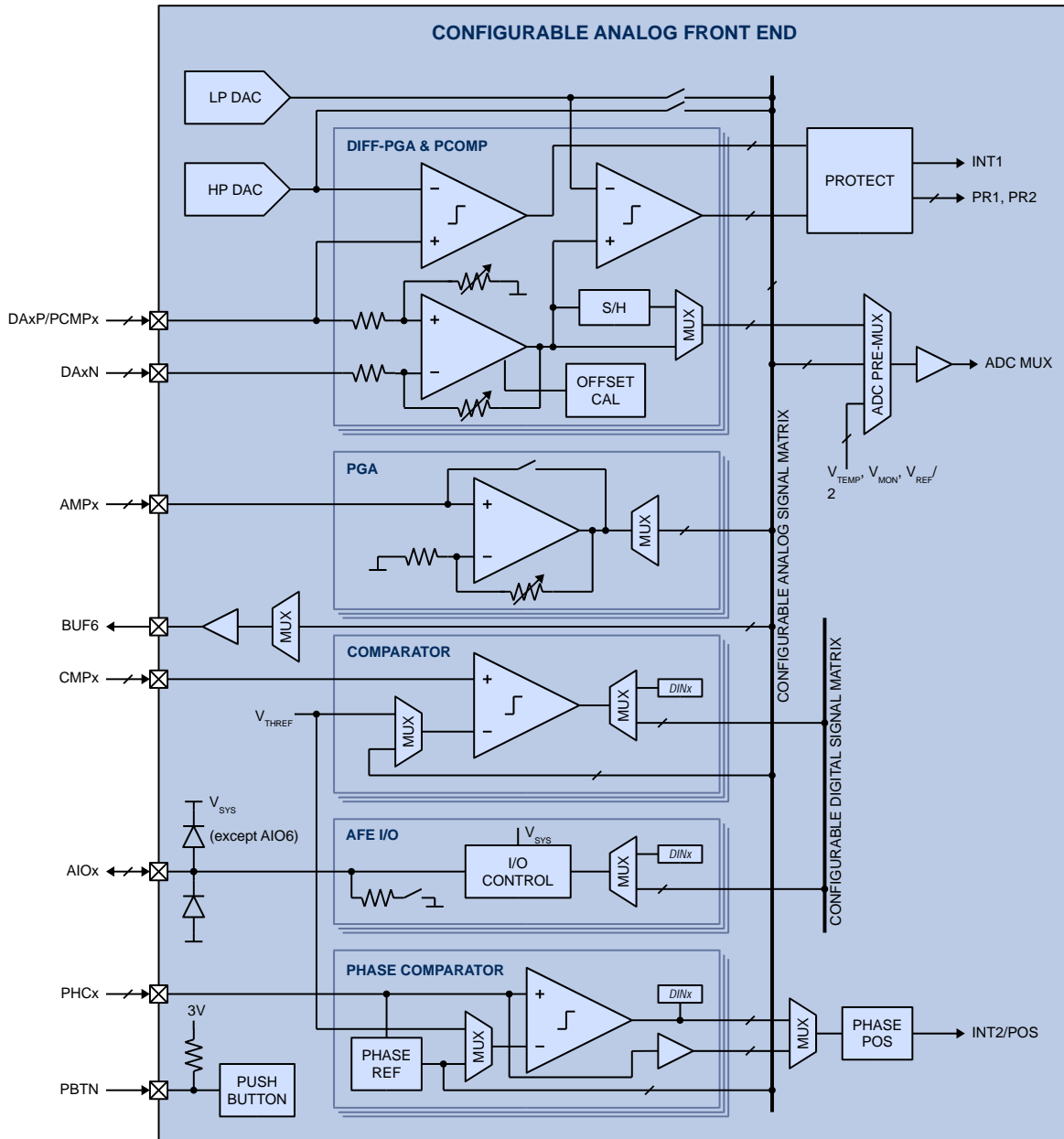

11.2 Functional Description

The device includes a Configurable Analog Front End (CAFE, [Figure 11-1](#)) accessible through up to 10 analog and I/O pins. These pins can be configured to form flexible interconnected circuitry made up of up to 3 differential programmable gain amplifiers, 4 single-ended programmable gain amplifiers, 4 general purpose comparators, 3 phase comparators, 10 protection comparators, and one buffer output. These pins can also be programmed as analog feed-through pins, or as analog front end I/O pins that can function as digital inputs or digital open-drain outputs. The PAC proprietary configurable analog signal matrix (CASM) and configurable digital signal matrix (CDSM) allow real time asynchronous analog and digital signals to be routed in flexible circuit connections for different applications. A push button function is provided for optional push button on, hibernate, and off power management function.

11.2.1 Differential Programmable Gain Amplifier (DA)

The DAXP and DAXN pin pair are positive and negative inputs, respectively, to a differential programmable gain amplifier. The differential gain can be programmable to be 1x, 2x, 4x, 8x, 16x, 32x, and 48x for zero ohm signal source impedance. The differential programmable gain amplifier has -0.3V to 2.5V input common mode range, and its output can be configured for routing directly to the ADC pre-multiplexer, or through a sample-and-hold circuit synchronized with the ADC auto-sampling mechanism. Each differential amplifier is accompanied by offset calibration circuitry, and two protection comparators for protection event monitoring. The programmable gain differential amplifier is optimized for use with signal source impedance lower than 500Ω and with matched source impedance on both positive and negative inputs for minimal offset. The effective gain is scaled by $13.5k / (13.5k + R_{SOURCE})$, where R_{SOURCE} is the matched source impedance of each input.

11.2.2 Single-Ended Programmable Gain Amplifier (AMP)

Each AMPx input goes to a single-ended programmable gain amplifier with signal relative to V_{SSA} . The amplifier gain can be programmed to be 1x, 2x, 4x, 8x, 16x, 32x, and 48x, or as analog feed-through. The programmable gain amplifier output is routed via a multiplexer to the configurable analog signal matrix CASM.

11.2.3 General Purpose Comparator (CMP)

The general purpose comparator takes the CMPx input and compares it to either the programmable threshold voltage (V_{THREF}) or a signal from the configurable analog signal matrix CASM. The comparator has 0V to V_{SYS} input common mode range, and its polarity-selectable output is routed via a multiplexer to either a data input bit or the configurable digital signal matrix CDSM. Each general purpose comparator has two mask bits to prevent or allow rising or falling edge of its output to trigger second microcontroller interrupt INT2, where INT2 can be configured to activate protection event PR1. Each comparator output, routed via CASM and with 500ns de-glitch time, can also be configured to activate protection event PR1.

11.2.4 Phase Comparator (PHC)

The phase comparator takes the PHCx input and compares it to either the programmable threshold voltage (V_{THREF}) or a signal from the configurable analog signal matrix CASM. The comparison signal can be set to a phase reference signal generated by averaging the PHCx input voltages. In a three-phase motor control application, the phase reference signal acts as a virtual center tap for BEMF detection. The PHCx inputs are optionally fed through to the CASM. The phase

comparator has 0V to V_{SYS} input common mode range, and its polarity-selectable output is routed to a data input bit and to the phase/position multiplexer synchronized with the auto-sampling sequencers.

11.2.5 Protection Comparator (PCMP)

Two protection comparators are provided in association with each differential programmable gain amplifier, with outputs available to trigger protection events and accessible as read-back output bits. The high-speed protection (HP) comparator compares the PCMPx pin to the 8-bit HP DAC output voltage, with full scale voltage of 2.5V. The limit protection (LP) comparator compares the differential programmable gain amplifier output to the 10-bit LP DAC output voltage, with full scale voltage of 2.5V.

Each protection comparator has a mask bit to prevent or allow it to trigger the main microcontroller interrupt INT1. Each protection comparator also has one mask bit to prevent or allow it to activate protection event PR1, and another mask bit to prevent or allow it to activate protection event PR2. These two protection events can be used directly by protection circuitry in the Application Specific Power Drivers (ASPD) to protect devices being driven.

11.2.6 Analog Output Buffer (BUF)

A subset of the signals from the configurable analog signal matrix CASM can be multiplexed to the BUF6 pin for external use. The buffer offset voltage can be minimized with the built-in swap function.

11.2.7 Analog Front End I/O (AIO)

Up to 10 AIOx pins are available in the device. In the analog front end I/O mode, the pin can be configured to be a digital input or digital open-drain output. The AIOx input or output signal can be set to a data input or output register bit, or multiplexed to one of the signals in the configurable digital signal matrix CDSM. The signal can be set to active high (default) or active low, with V_{SYS} supply rail. Where AIO_{6,7,8,9} supports microcontroller interrupt for external signals. Each has two mask bits to prevent or allow rising or falling edge of its corresponding digital input to trigger second microcontroller interrupt INT2.

11.2.8 Push Button (PBTN)

The push button PBTN, when enabled, can be used by the microcontroller to detect a user active-low push button event and to put the system into an ultra-low-power hibernate mode. Once the system is in hibernate mode, PBTN can be used to wake up the system. In addition, PBTN can also be used as a hardware reset for the microcontroller when it is held low for longer than 8s during normal operation. The PBTN input is active low and has a 55kΩ pull-up resistor to 3V.

11.2.9 HP DAC and LP DAC

The 8-bit HP DAC can be used as the comparison voltage for the high-speed protection (HP) comparators, or routed for general purpose use via the AB2 signal in the CASM. The HP DAC output full scale voltage is 2.5V.

The 10-bit LP DAC can be used as the comparison voltage for the limit protection (LP) comparators, or routed for general purpose use via the AB3 signal in the CASM. The LP DAC output full scale voltage is 2.5V.

11.2.10 ADC Pre-Multiplexer

The ADC pre-multiplexer is a 16-to-1 multiplexer that selects between the 3 differential programmable gain amplifier outputs, AB1 through AB9, temperature monitor signal (V_{TEMP}), power monitor signal (V_{MON}), and offset calibration reference ($V_{REF} / 2$). The ADC pre-multiplexer can be directly controlled or automatically scanned by the auto-sampling sequencer.

When the ADC pre-multiplexer is automatically scanned, the unbuffered or sensitive signals should be masked by setting appropriate register bits.

11.2.11 Configurable Analog Signal Matrix (CASM)

The CASM has 9 general purpose analog signals labeled AB1 through AB9 that can be used for:

- Routing the single-ended programmable gain amplifier or analog feed-through output to AB1 through AB9
- Routing an analog signal via AB1, AB2, or AB3 to the negative input of a general purpose comparator or phase comparator
- Routing the 8-bit HP DAC output to AB2
- Routing the 10-bit LP DAC output to AB3
- Routing analog signals via AB1 through AB12 to the ADC pre-multiplexer
- Routing phase comparator feed-through signals to AB7, AB8, and AB9, and averaged voltage to AB1

11.2.12 Configurable Digital Signal Matrix (CDSM)

The CDSM has 7 general purpose bi-directional digital signals labeled DB1 through DB7 that can be used for:

- Routing the AIOx input to or output signals from DB1 through DB7
- Routing the general purpose comparator output signals to DB1 through DB7

11.3 Electrical Characteristics

Table 11-1 Differential Programmable Gain Amplifier (DA) Electrical Characteristics

(V_{SYS} = V_{CC10} = 5V, V_{CC33} = 3.3V, and T_A = -40°C to 105°C unless otherwise specified.)

SYMBOL	PARAMETER	CONDITIONS	MIN	TYP	MAX	UNIT
I _{CC,DA}	Operating supply current	Each enabled amplifier		150	300	μA
V _{ICMR,DA}	Input common mode range		-0.3		2.5	V
V _{OLR,DA}	Output linear range		0.1		V _{SYS} - 0.1	V
V _{SHR,DA}	Sample and hold range		0.1		3.5	V
V _{OS,DA}	Input offset voltage	Gain = 48x, V _{DAxP} = V _{DAxN} = 0V, T _A = 25°C	-8		8	mV
A _{VZI,DA}	Differential amplifier gain (zero ohm source impedance)	Gain = 1x	-2%	1	2%	
		Gain = 2x		2		
		Gain = 4x		4		
		Gain = 8x, V _{DAxP} = 125mV, V _{DAxN} = 0V, T _A = 25°C		8		
		Gain = 16x		16		
		Gain = 32x		32		
		Gain = 48x		48		
K _{CMRR,DA}	Common mode rejection ratio	Gain = 8x, V _{DAxP} = V _{DAxN} = 0V, T _A = 25°C		55		dB
R _{INDIF,DA}	Differential input impedance			27		kΩ
	Slew rate ⁽¹⁾	Gain = 8x	7	10		V/μs
t _{ST,DA}	Settling time ⁽¹⁾	To 1% of final value		200	400	ns

⁽¹⁾ Guaranteed by design.

Table 11-2 Single-Ended Programmable Gain Amplifier (AMP) Electrical Characteristics

($V_{SYS} = V_{CCIO} = 5V$, $V_{CC33} = 3.3V$, and $T_A = -40^{\circ}C$ to $105^{\circ}C$ unless otherwise specified.)

SYMBOL	PARAMETER	CONDITIONS	MIN	TYP	MAX	UNIT
$I_{CC,AMP}$	Operating supply current	Each enabled amplifier		80	140	μA
$V_{ICMR,AMP}$	Input common mode range		0		V_{SYS}	V
$V_{OLR,AMP}$	Output linear range		0.1		$V_{SYS} - 0.1$	V
$V_{OS,AMP}$	Input offset voltage	Gain = 1x, $T_A = 25^{\circ}C$, $V_{AMPX} = 2.5V$	-10		10	mV
$A_{V,AMP}$	Amplifier gain	Gain = 1x	-2%	1	2%	
		Gain = 2x		2		
		Gain = 4x		4		
		Gain = 8x, $V_{AMPX} = 125mV$, $T_A = 25^{\circ}C$		8		
		Gain = 16x		16		
		Gain = 32x		32		
		Gain = 48x		48		
$I_{IN,AMP}$	Input current			0	1	μA
	Slew rate ⁽¹⁾	Gain = 8x	8	12		V/ μs
$t_{ST,AMP}$	Settling time ⁽¹⁾	To 1% of final value		150	300	ns

⁽¹⁾ Guaranteed by design.

Table 11-3 General Purpose Comparator (CMP) Electrical Characteristics

($V_{SYS} = V_{CCIO} = 5V$, $V_{CC33} = 3.3V$, and $T_A = -40^{\circ}C$ to $105^{\circ}C$ unless otherwise specified.)

SYMBOL	PARAMETER	CONDITIONS	MIN	TYP	MAX	UNIT
$I_{CC,CMP}$	Operating supply current	Each enabled comparator		35	110	μA
$V_{ICMR,CMP}$	Input common mode range		0		V_{SYS}	V
$V_{OS,CMP}$	Input offset voltage	$V_{CMPX} = 2.5V$, $T_A = 25^{\circ}C$	-10		10	mV
$V_{HYS,CMP}$	Hysteresis			23		mV
$I_{IN,CMP}$	Input current			0	1	μA
$t_{DEL,CMP}$	Comparator delay ⁽¹⁾				0.1	μs

⁽¹⁾ Guaranteed by design.

Table 11-4 Phase Comparator (PHC) Electrical Characteristics

($V_{SYS} = V_{CCIO} = 5V$, $V_{CC33} = 3.3V$, and $T_A = -40^{\circ}C$ to $105^{\circ}C$ unless otherwise specified.)

SYMBOL	PARAMETER	CONDITIONS	MIN	TYP	MAX	UNIT
$I_{CC;PHC}$	Operating supply current	Each enabled comparator		35	110	μA
$V_{ICMR;PHC}$	Input common mode range		0		V_{SYS}	V
$V_{OS;PHC}$	Input offset voltage	$V_{PHCx} = 2.5V$, $T_A = 25^{\circ}C$	-10		10	mV
$V_{HYS;PHC}$	Hysteresis			23		mV
$I_{IN;PHC}$	Input current			0	1	μA
$t_{DEL;PHC}$	Comparator delay ⁽¹⁾				0.1	μs

⁽¹⁾ Guaranteed by design.

Table 11-5 Protection Comparator (PCMP) Electrical Characteristics

($V_{SYS} = V_{CCIO} = 5V$, $V_{CC33} = 3.3V$, and $T_A = -40^{\circ}C$ to $105^{\circ}C$ unless otherwise specified.)

SYMBOL	PARAMETER	CONDITIONS	MIN	TYP	MAX	UNIT
$I_{CC;PCMP}$	Operating supply current	Each enabled comparator		35	100	μA
$V_{ICMR;PCMP}$	Input common mode range		0.3		$V_{SYS} - 1$	V
$V_{OS;PCMP}$	Input offset voltage	$V_{PCMPx} = 2.5V$, $T_A = 25^{\circ}C$	-10		10	mV
$V_{HYS;PCMP}$	Hysteresis			20		mV
$I_{IN;PCMP}$	Input current			0	1	μA
$t_{DEL;PCMP}$	Comparator delay ⁽¹⁾				0.1	μs

⁽¹⁾ Guaranteed by design.

Table 11-6 Analog Output Buffer (BUF) Electrical Characteristics

($V_{SYS} = V_{CCIO} = 5V$, $V_{CC33} = 3.3V$, and $T_A = -40^{\circ}C$ to $105^{\circ}C$ unless otherwise specified.)

SYMBOL	PARAMETER	CONDITIONS	MIN	TYP	MAX	UNIT
$I_{CC;BUF}$	Operating supply current	No load		35	100	μA
$V_{ICMR;BUF}$	Input common mode range		0.05		3.5	V
$V_{OLR;AMP}$	Output linear range		0.1		3.5	V
$V_{OS;BUF}$	Offset voltage	$V_{BUF} = 2.5V$, $T_A = 25^{\circ}C$	-18		18	mV
I_{OMAX}	Maximum output current	$C_L = 0.1nF$	0.8	1.3		mA

Table 11-7 Analog Front End I/O (AIO) Electrical Characteristics

($V_{SYS} = V_{CCIO} = 5V$, and $T_A = -40^{\circ}C$ to $105^{\circ}C$ unless otherwise specified.)

SYMBOL	PARAMETER	CONDITIONS	MIN	TYP	MAX	UNIT
V_{AIO}	Pin voltage range		0		5	V
$V_{IH,AIO}$	High-level input voltage		2.2			V
$V_{IL,AIO}$	Low-level input voltage				0.8	V
$R_{PD,AIO}$	Pull-down resistance	Input mode	0.5	1	1.8	MΩ
$V_{OL,AIO}$	Low-level output voltage	$I_{AIOx} = 7mA$, open-drain output mode			0.4	V
$I_{OL,AIO}$	Low-level output sink current	$V_{AIOx} = 0.4V$, open-drain output mode	6	14		mA
$I_{LK,AIO}$	High-level output leakage current	$V_{AIOx} = 5V$, open-drain output mode		0	10	μA

Table 11-8 Push Button (PBTN) Electrical Characteristics

($V_{SYS} = V_{CCIO} = 5V$, and $T_A = -40^{\circ}C$ to $105^{\circ}C$ unless otherwise specified.)

SYMBOL	PARAMETER	CONDITIONS	MIN	TYP	MAX	UNIT
$V_{I,PBTN}$	Input voltage range		0		5	V
$V_{IH,PBTN}$	High-level input voltage		2			V
$V_{IL,PBTN}$	Low-level input voltage				0.35	V
$R_{PU,PBTN}$	Pull-up resistance	To 3V, push button input mode	40	55	95	kΩ

Table 11-9 HP DAC and LP DAC Electrical Characteristics

($V_{SYS} = V_{CCIO} = 5V$, and $T_A = -40^{\circ}C$ to $105^{\circ}C$ unless otherwise specified.)

SYMBOL	PARAMETER	CONDITIONS	MIN	TYP	MAX	UNIT
V_{DACREF}	DAC reference voltage	$T_A = 25^{\circ}C$	2.480	2.5	2.520	V
		$T_A = -40^{\circ}C$ to $105^{\circ}C$	2.453	2.5	2.547	
	HP 8-bit DAC INL ⁽¹⁾		-1		1	LSB
	HP 8-bit DAC DNL ⁽¹⁾		-0.5		0.5	LSB
	LP 10-bit DAC INL ⁽¹⁾		-2		2	LSB
	LP 10-bit DAC DNL ⁽¹⁾		-1		1	LSB

⁽¹⁾ Guaranteed by design and characterization.

11.4 Typical Performance Characteristics

($V_{SYS} = 5V$ and $T_A = 25^\circ C$ unless otherwise specified.)

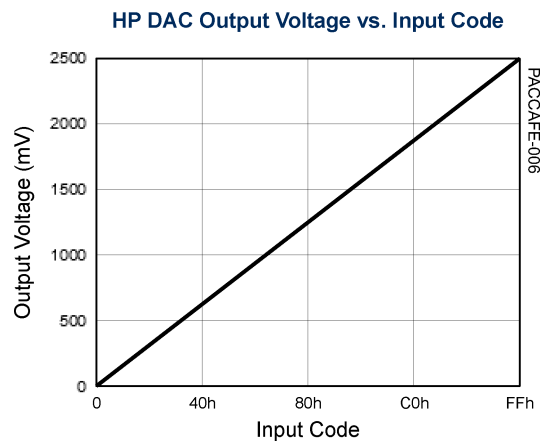
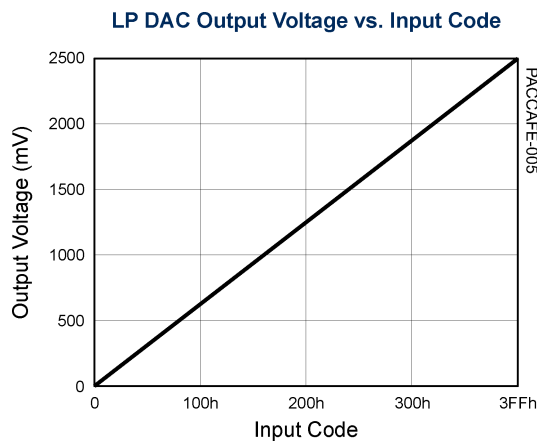
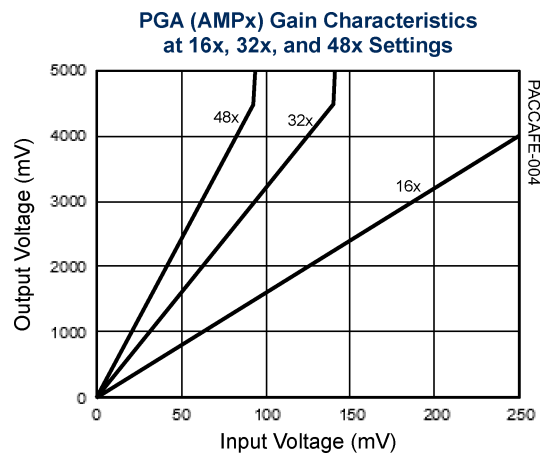
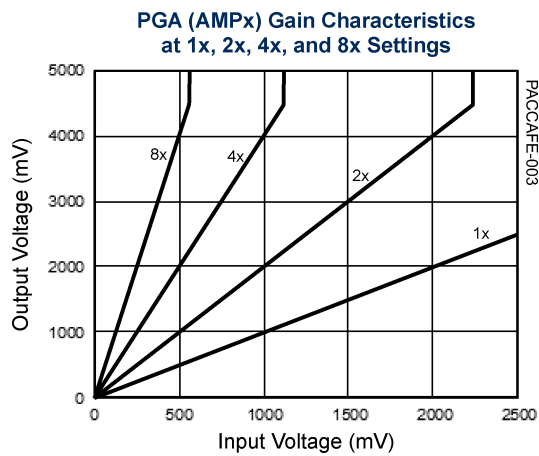
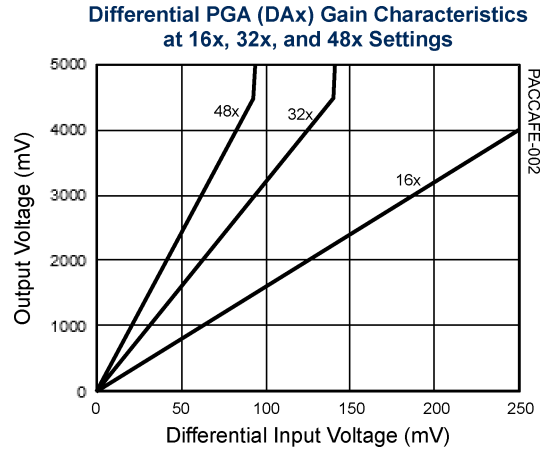
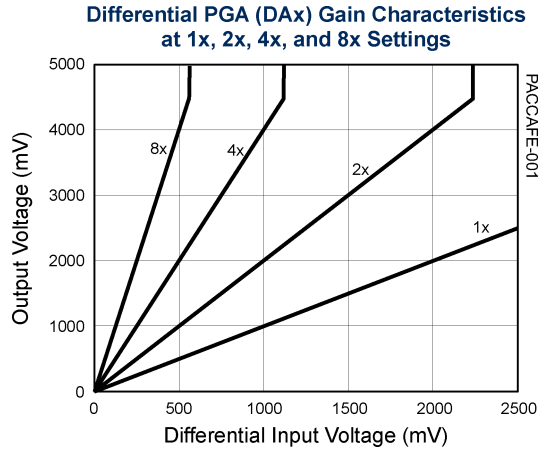

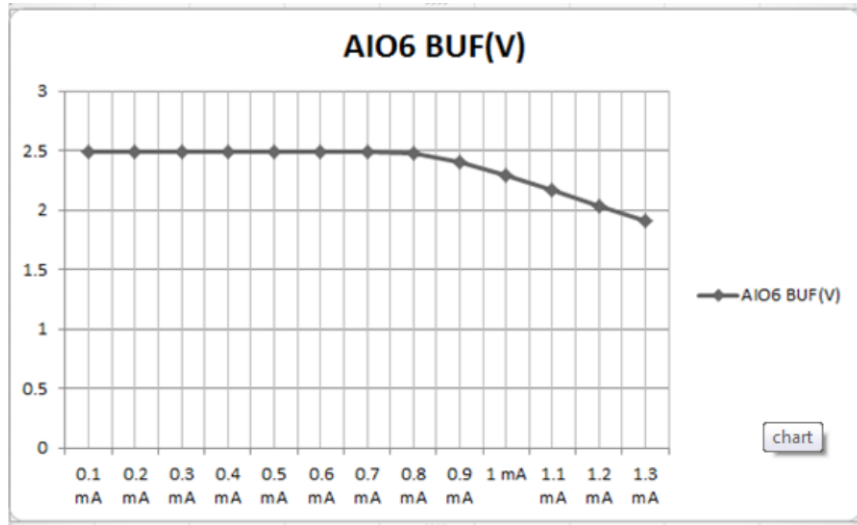

12 APPLICATION SPECIFIC POWER DRIVERS (ASPD)

12.1 Features

- 6 low-side and 3 ultra-high-voltage high-side gate drivers
- 2 open-drain drivers
- Configurable delays and fast fault protection

12.2 Block Diagram

Figure 12-1 Application Specific Power Drivers

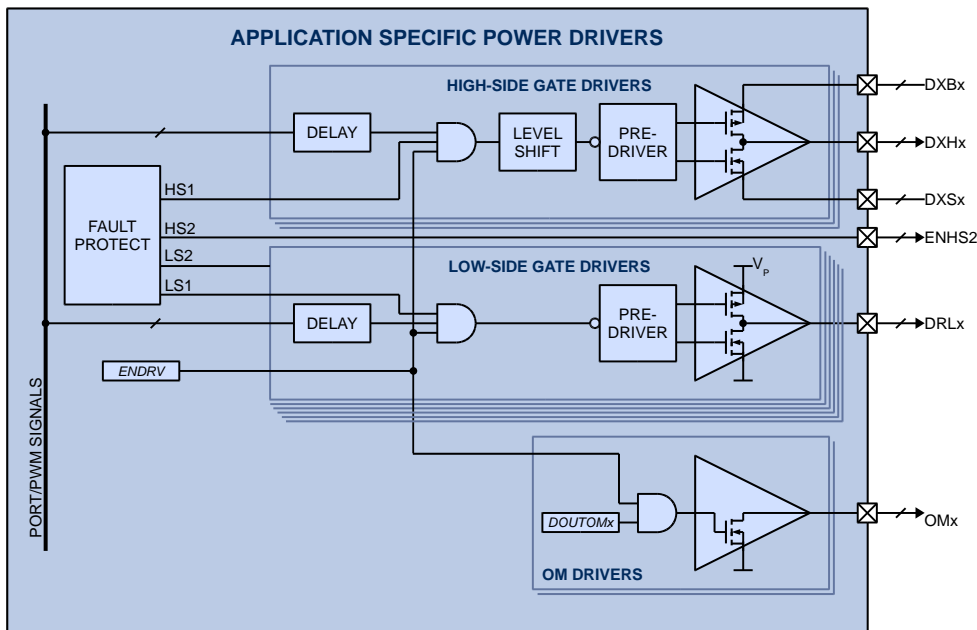

12.3 Functional Description

The Application Specific Power Drivers (ASPD, [Figure 12-1](#)) module handles power driving for power control applications. PAC5250 has six low-side gate drivers (DRLx), three ultra-high-voltage high-side gate drivers (DXHx), two medium-voltage open-drain drivers (OMx). Each gate driver can drive an external MOSFET or IGBT switch in response to high-speed control signals from the microcontroller ports, and a pair of high-side and low-side gate drivers can form a half-bridge driver. The open-drain drivers provide activation control for relays, LEDs, buffers, and other loads.

[Figure 12-2](#) below shows typical gate driver connections and [Table 12-1](#) shows the ASPD resources available on PAC5250.

Figure 12-2 Typical Gate Driver Connections

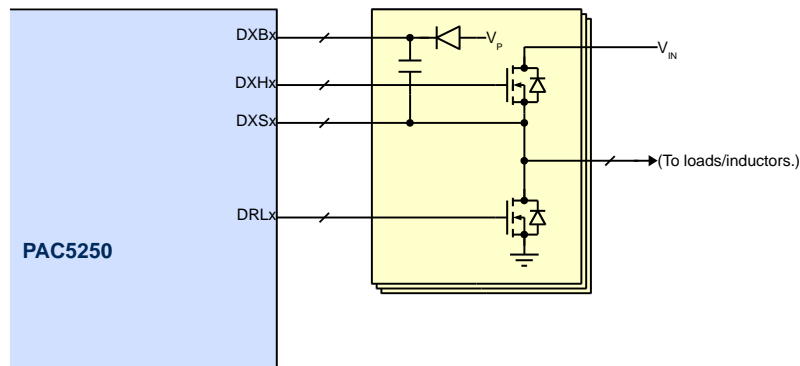

Table 12-1 Power Driver Resources by Part Number

PART NUMBER	LOW-SIDE GATE DRIVER		HIGH-SIDE GATE DRIVER			OPEN-DRAIN DRIVER
	DRLx	SOURCE/ SINK CURRENT	DXHx	MAX SUPPLY	SOURCE/ SINK CURRENT	OHlx
PAC5250	6	1A/1A	3	600V	0.25A/0.5A	2 (23V/40mA)

The ASPD includes built-in configurable fault protection for the internal gate drivers. On PAC5250, the protection signal ENHS2 are provided for external circuitry driver fault protection.

12.3.1 Low-Side Gate Driver

The DRLx low-side gate driver drives the gate of an external MOSFET or IGBT switch between the low-level V_{SSP} power ground rail and high-level V_P supply rail. The DRLx output pin has sink and source output current capability of 1A. Each low-side gate driver is controlled by a microcontroller port signal with 4 configurable levels of propagation delay.

12.3.2 Ultra-High-Voltage Gate Driver

The DXHx ultra-high-voltage high-side gate driver drives the gate of an external MOSFET or IGBT switch between its low-level DXSx driver source rail and its high-level DXBx bootstrap rail. The DXSx pin can go up to 600V. The DXHx output pin has 0.5A sink and 0.25A source output current capability. The DXBx bootstrap pin can have a maximum operating voltage of 20V relative to the DXSx pin. The DXSx pin is designed to tolerate momentary switching negative spikes down to -10V without affecting the DXHx output state. Each ultra-high-voltage high-side gate driver is controlled by a microcontroller port signal.

For bootstrapped high-side operation, connect an appropriate capacitor between DXBx and DXSx and a properly rated bootstrap diode from V_P rail to DXBx.

12.3.3 High-Side Switching Transients

Typical high-side switching transients are shown in [Figure 12-3\(a\)](#). To ensure functionality and reliability, the DXSx and DXBx pins must not exceed the peak and undershoot limit values shown. This should be verified by probing the DXSx and DXBx pins directly relative to VSS pin. A small resistor and diode clamp for the DXSx pin can be used to make sure that the pin voltage stays within the negative limit value. In addition, the high-side slew rate dV/dt must be kept within $\pm 50V/ns$ for DXSx. This can be achieved by adding a resistor-diode pair in series, and an optional capacitor in parallel with the power switch gate. The parallel capacitor also provides a low impedance and close gate shunt against coupling from the switch drain. These optional protection and slew rate control are shown in [Figure 12-3\(b\)](#).

Figure 12-3 High-Side Switching Transients and Optional Circuitry

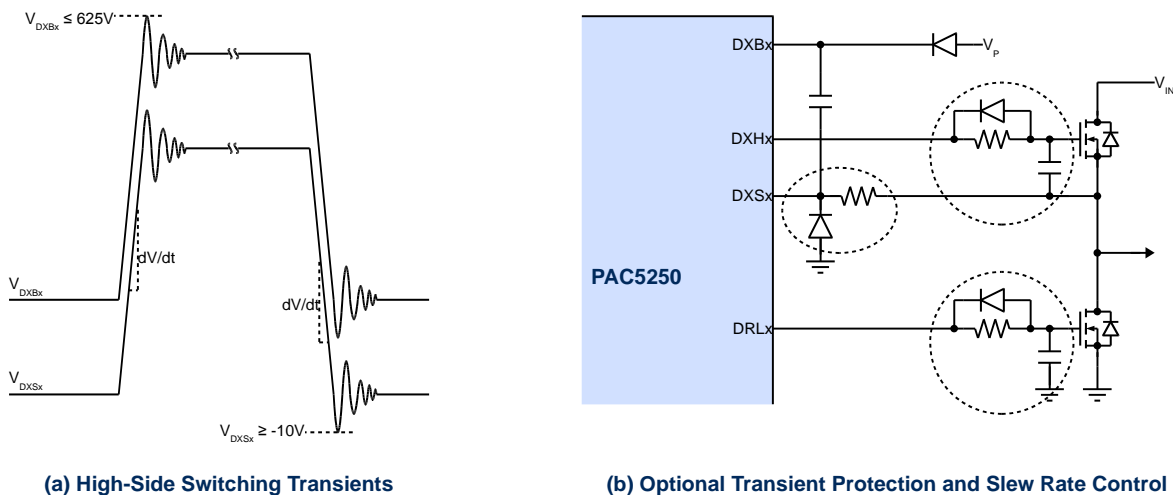

12.3.4 Open-Drain Drivers

The OMx pin is a 23V open-drain driver output controlled by a register bit. OMx is capable of driving 40mA. The OMx pin is switched to VSSP with 17Ω impedance in the on state when the corresponding bit is '1', and is in the high-impedance off state when the corresponding bit is '0'.

12.3.5 Power Drivers Control

All power drivers are initially disabled from power-on-reset. To enable the power drivers, the microprocessor must first set the driver enable bit to '1'. The gate drivers controlled by the microcontroller ports and PWM signals according to [Table 12-2](#), with configurable delays as shown in [Table 12-3](#). The OMx open-drain drivers are controlled by their corresponding register bits. Refer to the PAC application notes and user guide for additional information on power drivers control programming.

Table 12-2 Microcontroller Port and PWM to Power Driver Mapping

PART NUMBER	PWMA0	PWMA1	PWMA2	PWMA3/ PWMA4/ PWMB0	PWMA5/ PWMC0	PWMA6/ PWMD0	PWMA4/ PWMB0	PWMA5/ PWMA7/ PWMC1	PWMA6/ PWMD0
PAC5250	DRL0	DRL1	DRL2	DRL3	DRL4	DRL5	DXH0	DXH1	DXH2

Table 12-3 Power Driver Propagation Delay

DRLx		DXHx	
RISING	FALLING	RISING	FALLING
130ns	140ns	200ns	240ns

12.3.6 Gate Driver Fault Protection

The ASPD incorporates a configurable fault protection mechanism using two protection event signals from the Configurable Analog Front End (CAFE), designated as protection event 1 (PR1) and protection event 2 (PR2) signals. The DRL0/DRL1/DRL2 drivers are designated as low-side group 1, and the DRL3/DRL4/DRL5 gate drivers are designated as low-side group 2. The DXH0/DXH1/DXH2 ultra-high-voltage gate drivers are designated as high-side group 1. The PR1 signal from the CAFE can be used to disable low-side group 1, high-side group 1, or both depending on the PR1 mask bit settings. The PR2 signal from the CAFE can be used to disable low-side group 2, high-side group 2, or both depending on the PR2 mask bit settings. ENHS2 (high-side group 2 control output) pin is provided for enabling external power drivers with fault protection.

12.4 Electrical Characteristics

Table 12-4 Gate Drivers Electrical Characteristics

($V_P = 12V$, $V_{SYS} = 5V$, and $T_A = -40^\circ C$ to $105^\circ C$ unless otherwise specified.)

SYMBOL	PARAMETER	CONDITIONS	MIN	TYP	MAX	UNIT
Low-Side Gate Drivers (DRLx Pins)						
$V_{OH,DRL}$	High-level output voltage	$I_{DRLx} = -50mA$	$V_P - 0.5$	$V_P - 0.25$		V
$V_{OL,DRL}$	Low-level output voltage	$I_{DRLx} = 50mA$		0.175	0.35	V
$I_{OHPK,DRL}$	High-level pulsed peak source current	10 μs pulse		-1		A
$I_{OLPK,DRL}$	Low-level pulsed peak sink current	10 μs pulse		1		A
$T_{PD,DRL}$	Propagation Delay ²	Delay setting 00		Delay + 0		ns
		Delay setting 01		Delay + 50		
		Delay setting 10		Delay + 100		
		Delay setting 11		Delay + 200		
Ultra-High-Voltage Gate Drivers (DXHx, DXBx and DXSx Pins)						
V_{DxS}	Level-shift driver source voltage range	Repetitive, 10 μs pulse	-10		605	V
		Steady state	0		600	
V_{DxB}	Bootstrap pin voltage range	Repetitive, 10 μs pulse	1		625	V
		Steady state	9		620	
$V_{BS,DxB}$	Bootstrap supply voltage range	V_{DxBx} , relative to respective V_{DxSx}	9		20	V
$V_{UVLO,DxB}$	Bootstrap UVLO threshold	V_{DxBx} rising, relative to respective V_{DxSx} , $Hys=0.5V$	6.3	7.5	9.3	V
$I_{BS,DxB}$	Bootstrap supply current			40	80	μA
$I_{OS,DxB}$	Offset supply current	$V_{DxBx} = V_{DxSx} = 600V$			10	μA
$V_{OH,DXH}$	High-level output voltage	$I_{DXHx} = -20mA$	$V_{DxBx} - 0.6$			V
$V_{OL,DXH}$	Low-level output voltage	$I_{DXHx} = 40mA$			$V_{DxSx} + 0.6$	V
$I_{OHPK,DXH}$	High-level pulsed peak source current	10 μs pulse		-0.25		A
$I_{OLPK,DXH}$	Low-level pulsed peak sink current	10 μs pulse		0.5		A

² Delay from [Power Driver Propagation Delay](#)

Table 12-5 Open-Drain Drivers Electrical Characteristics

($V_P = 12V$, $V_{SYS} = 5V$, and $T_A = -40^{\circ}C$ to $105^{\circ}C$ unless otherwise specified.)

SYMBOL	PARAMETER	CONDITIONS	MIN	TYP	MAX	UNIT
Medium-Voltage Open-Drain Drivers (OMx Pins)						
V_{OM}	Output voltage range	Off state	0		23	V
$R_{ON;OM}$	On state resistance	$I_{OMx} = 20mA$		17	35	Ω
$I_{OL;OM}$	On state sink current	$V_{OMx} = 2V$	40	80		mA
$I_{LK;OM}$	Leakage current	$V_{OMx} = 23V$, off state		0	10	μA

Table 12-6 Power Drivers Module Electrical Characteristics

($V_P = 12V$, $V_{SYS} = 5V$, and $T_A = -40^{\circ}C$ to $105^{\circ}C$ unless otherwise specified.)

SYMBOL	PARAMETER	CONDITIONS	MIN	TYP	MAX	UNIT
High-Side Driver Group Control Output (ENHS2 Pin)						
$V_{OH;ENHS2}$	High-level output voltage	$I_{ENHS2} = -3mA$	2.4			V
$V_{OL;ENHS2}$	Low-level output voltage	$I_{ENHS2} = 1mA$			0.4	V
$I_{OH;ENHS2}$	High-level output source current	$V_{ENHS2} = 2.4V$		-5.8	-4.3	mA
$I_{OL;ENHS2}$	Low-level output sink current	$V_{ENHS2} = 0.4V$	1	1.5		mA

12.5 Typical Performance Characteristics

($V_P = 12V$, $V_{SYS} = 5V$ and $T_A = 25^\circ C$ unless otherwise specified.)

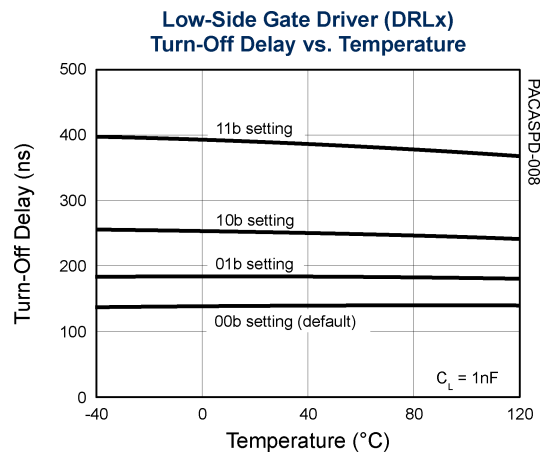
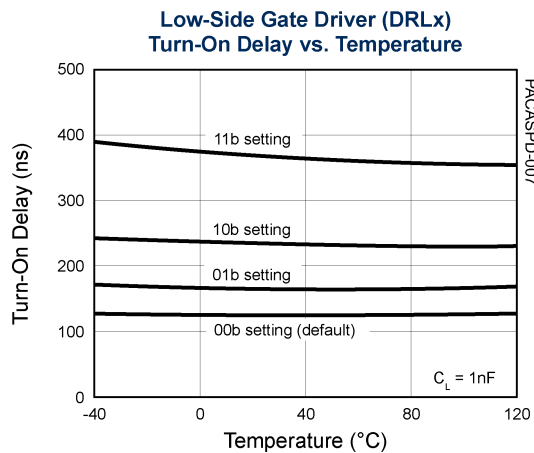
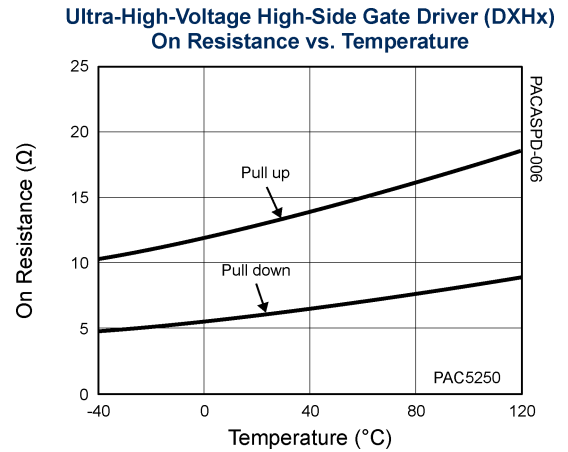
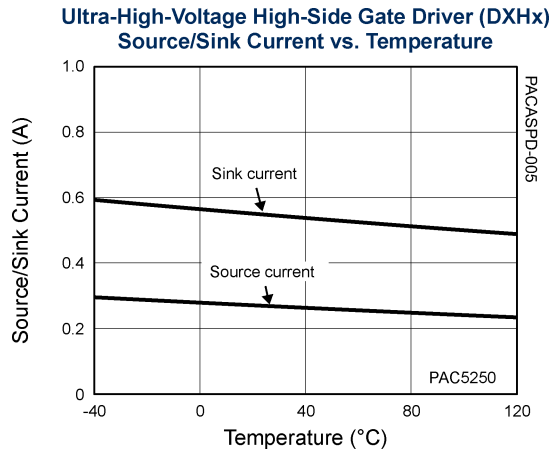
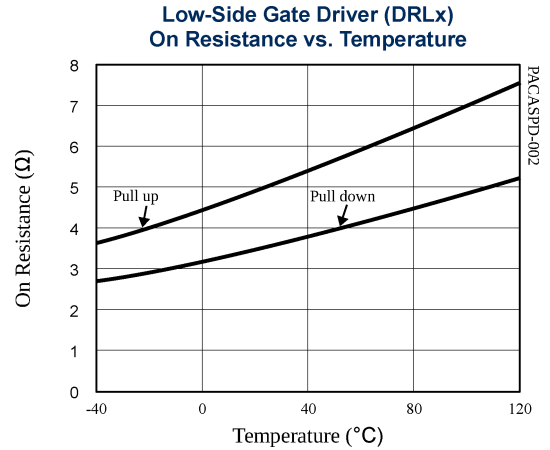
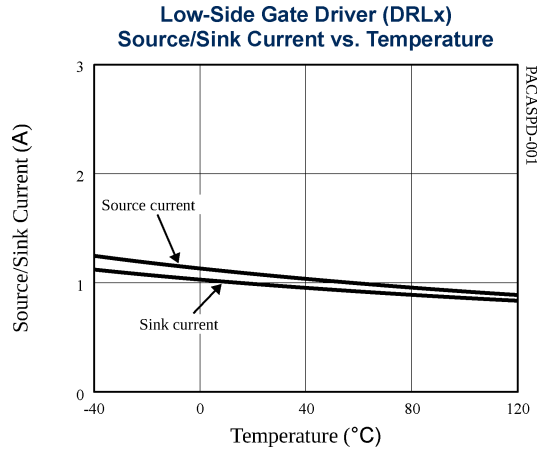

Typical Performance Characteristics (Continued)

($V_P = 12V$, $V_{SYS} = 5V$ and $T_A = 25^\circ C$ unless otherwise specified.)

Ultra-High-Voltage High-Side Gate Driver (DXHx)
Turn-On Delay vs. Temperature

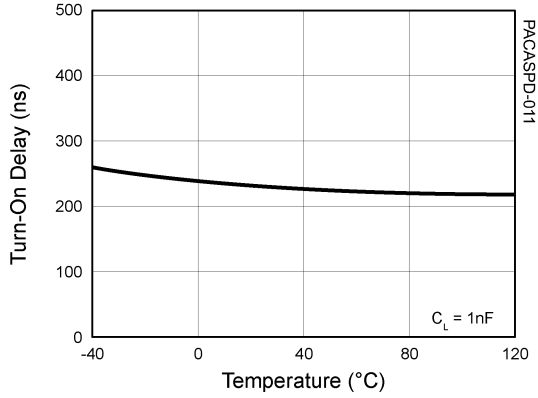

Ultra-High-Voltage High-Side Gate Driver (DXHx)
Turn-Off Delay vs. Temperature

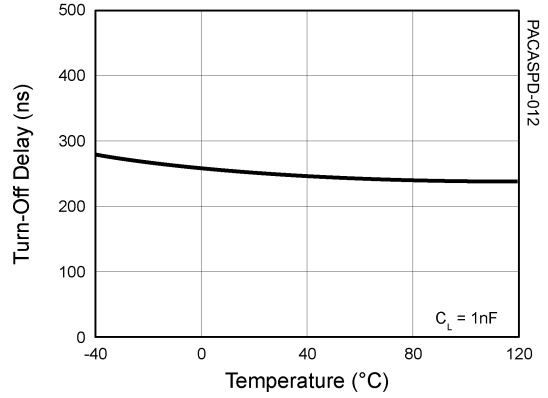

OMx Open-Drain Driver On State
Output Voltage vs. Output Current

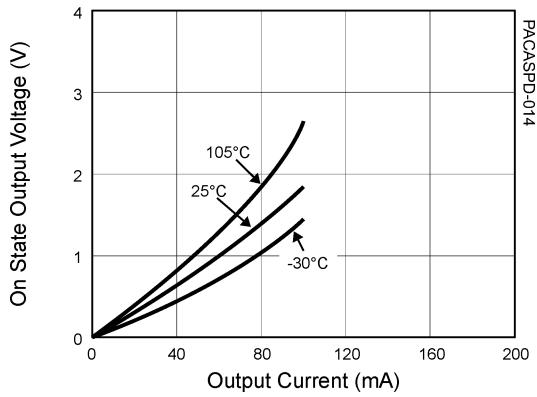

13 ADC WITH AUTO-SAMPLING SEQUENCER

13.1 Block Diagram

Figure 13-1 ADC with Auto-Sampling Sequencer

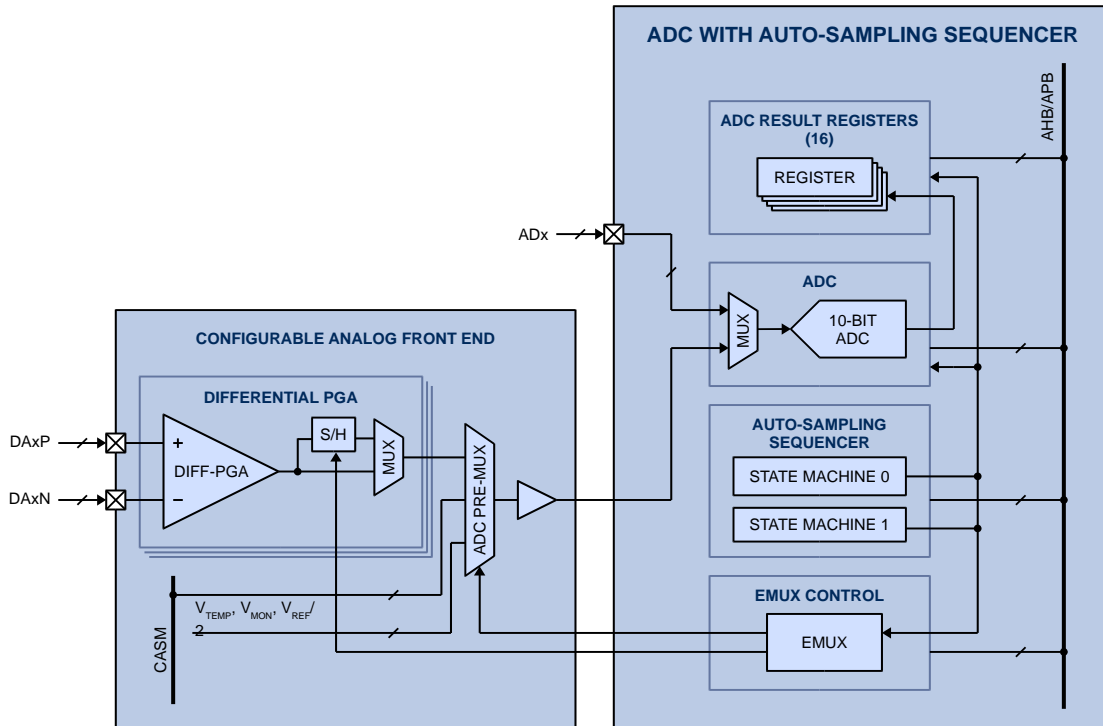

13.2 Functional Description

13.2.1 ADC

The analog-to-digital converter (ADC) is a 10-bit successive approximation register (SAR) ADC with 1 μ s conversion time and up to 1MSPS capability. The ADC input clock has a user-configurable divider from /1 to /8 of the system clock. The integrated analog multiplexer allows selection from up to 6 direct ADx inputs, and from up to 10 analog inputs signals in the Configurable Analog Front End (CAFE), including up to 3 differential input pairs. The ADC can be configured for repeating or non-repeating conversions and can interrupt the microcontroller when a conversion is finished.

13.2.2 Auto-Sampling Sequencer

Two independent and flexible auto-sampling sequencer state machines allow signal sampling using the ADC without interaction from microcontroller core. Each auto-sampling sequencer state machine can be programmed to take and store up to 8 samples each in the ADC result register from different analog inputs, able to control the ADC MUX and ADC Premux as well as the precise timing of the S/H in the Configurable analog front end. The sampling start of the auto-sampling sequencer can be precisely triggered using timers A, B, C, or D or any of their associated PWM edges (high-to-low or low-

to-high). It also supports manual start or a ping-pong-scheme, where one auto-sampling sequencer state machine triggers the other when it finishes sampling.

The auto-sampling sequencer can interrupt the microcontroller when either conversion sequence is finished.

13.2.3 EMUX Control

A dedicated low latency interface controllable by the auto-sampling sequencer or register control allows changing the ADC premultiplexer and asserting/deasserting the S/H circuit in the configurable analog front end, allowing back to back conversions of multiple analog inputs without microcontroller interaction.

13.3 Electrical Characteristics

Table 13-1 ADC and Auto-Sampling Sequencer Electrical Characteristics

($V_{SYS} = V_{CCIO} = 5V$, $V_{CC33} = 3.3V$, $V_{CC18} = 1.8V$, and $T_A = -40^{\circ}C$ to $105^{\circ}C$ unless otherwise specified.)

SYMBOL	PARAMETER	CONDITIONS	MIN	TYP	MAX	UNIT
ADC						
f_{ADCLK}	ADC conversion clock input				16	MHz
t_{ADCONV}	ADC conversion time	$f_{ADCLK} = 16MHz$			1	μs
	ADC resolution			10		bits
	ADC effective resolution		9.2			bits
	ADC differential non-linearity (DNL)			± 0.5		LSB
	ADC integral non-linearity (INL)			± 1		LSB
	ADC offset error			0.6		%FS
	ADC gain error			0.12		%FS
Reference Voltage						
V_{REFADC}	ADC reference voltage input			2.5		V
Sample and Hold						
t_{ADCSH}	ADC sample and hold time	$f_{ADCLK} = 16MHz$		188		ns
C_{ADCIC}	ADC input capacitance			1.3		pF
Input Voltage Range						
V_{ADCIN}	ADC input voltage range	ADC multiplexer input	0		V_{REFADC}	V
EMUX Clock Speed						
$f_{EMUXCLK}$	EMUX engine clock input				50	MHz
PLL Clock Speed						
f_{OUTPLL}	PLL output frequency	$T_A = -40^{\circ}C$ to $85^{\circ}C$	3.5		100	MHz
		$T_A = 85^{\circ}C$ to $105^{\circ}C$	3.5		80	MHz

14 MEMORY SYSTEM

14.1 Features

- 32kB embedded FLASH
 - ◆ 100,000 program/erase cycles
 - ◆ 10 years data retention
- 8kB SRAM

14.2 Block Diagram

Figure 14-1 Memory System

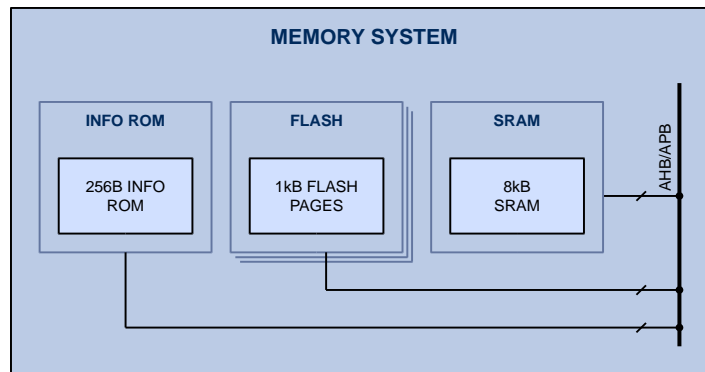

14.3 Functional Description

The device has multiple banks of embedded FLASH memory, SRAM memory, as well as peripheral control registers that are all program-accessible in a flat memory map.

14.3.1 Program and Data FLASH

32kB in 32 pages of 1kB each is available for program or data memory. Each of them can be individually erased or written to while the microcontroller is executing a program from SRAM.

14.3.2 SRAM

Up to 8kB contiguous array of SRAM is available for non-persistent data storage. The SRAM memory supports word (4-byte), half-word (2-byte) and byte address aligned access. The microcontroller may execute code out of SRAM for time-critical applications, or when modifying the contents of FLASH memory.

14.4 Electrical Characteristics

Table 14-1 Memory System Electrical Characteristics

($V_{SYS} = V_{CC10} = 5V$, $V_{CC33} = 3.3V$, $V_{CC18} = 1.8V$, and $T_A = -40^{\circ}C$ to $105^{\circ}C$ unless otherwise specified.)

SYMBOL	PARAMETER	CONDITIONS	MIN	TYP	MAX	UNIT
Embedded FLASH						
$t_{READ;FLASH}$	FLASH read time		40			ns
$t_{WRITE;FLASH}$	FLASH write time		20			μs
$t_{PERASE;FLASH}$	FLASH page erase time				10	ms
$N_{PERASE;FLASH}$	FLASH program/erase cycles			100k		cycles
$t_{DR;FLASH}$	FLASH data retention		10			years
SRAM						
t_{SRAM}	SRAM access cycle time		20			ns

15 CLOCK CONTROL SYSTEM

15.1 Features

- Ring oscillator with 7.5MHz, 9.6MHz, 13.8MHz, and 25.7MHz settings
- High accuracy 2% trimmed 4MHz RC oscillator
- Crystal oscillator driver supporting 2MHz to 10MHz crystals
- External clock input up to 40MHz
- PLL with 1MHz to 25 MHz input, and 3.5MHz to 100MHz output
- /1 to /8 clock divider for HCLK
- /1 to /128 clock divider for ACLK

15.2 Block Diagram

Figure 15-1 Clock Control System

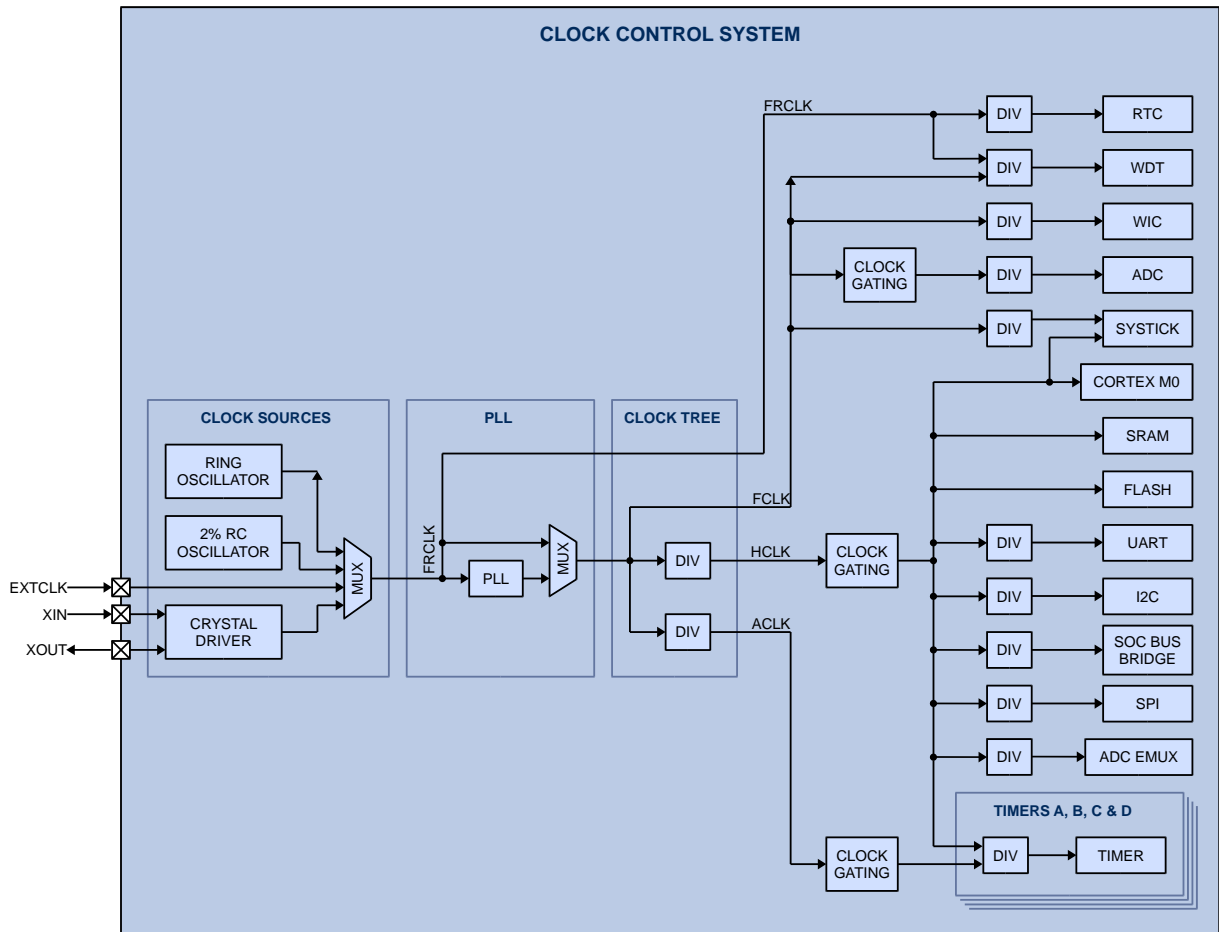

15.3 Functional Description

The PAC clock control system covers a wide range of applications.

15.3.1 Free Running Clock (FRCLK)

The free running clock (FRCLK) is generated from one of the 4 clock sources: ring oscillator, trimmed RC oscillator, crystal driver or external clock input. The FRCLK is used for the real-time clock (RTC), watchdog timer (WDT), input to the PLL, or FCLK source to clock the system in low power and sleep mode.

15.3.2 Fast Clock (FCLK)

The fast clock (FCLK) is generated from the PLL or supplied by the FRCLK directly. The FCLK supplies the watchdog timer (WDT), ADC, wake-up interrupt controller (WIC), SysTick timer, Arm® Cortex®-M0 peripheral high speed clock (HCLK) and low speed clock (LSCLK).

15.3.3 High-Speed Clock (HCLK)

The high-speed clock (HCLK) is derived from the FCLK with a /1, /2, /4 or /8 divider. It supplies the peripheral AHB/APB bus, Timers A to D, dead-time controllers, SPI interface, I²C interface, UART interface, EMUX interface, SOC bus bridge and memory subsystem, and can go as high as 50MHz.

15.3.4 Auxiliary Clock (ACLK)

The auxiliary clock (ACLK) is derived from FCLK with a /1, /2, to /128 divider, and supplies the timer and dead-time blocks. It can be clocked faster or slower than HCLK and can go as high as 100MHz.

15.3.5 Clock Gating

The clock tree supports clock gating in deep-sleep mode for the timer block, ADC, SPI interface, I²C interface, UART interface, memory subsystem and the Arm® Cortex®-M0 itself.

15.3.6 Ring Oscillator (ROSC)

The integrated ring oscillator provides 4 different clocks with 7.5MHz, 9.6MHz, 13.8MHz, and 25.7MHz settings. After reset, the clock tree always defaults to this clock input with the lowest frequency setting.

15.3.7 Trimmed 4MHz RC Oscillator

The 2% trimmed 4MHz RC oscillator provides an accurate clock suitable for many applications. It is also used to derive the clock for the Multi-Mode Power Manager.

15.3.8 Internal Slow RC Oscillator

An internal 32kHz RC oscillator is used during start up to provide an initial clock to analog circuitry. It is not used as a clock input to the clock tree.

15.3.9 Crystal Oscillator Driver

The optional crystal oscillator driver can drive crystals from 2MHz to 10MHz to provide a highly accurate and stable clock into the system.

15.3.10 External Clock Input

The clock tree can be supplied with an external clock up to 10MHz.

15.3.11 PLL

The integrated PLL input clock is supplied by the FRCLK with an input frequency range of 1MHz to 25MHz. The PLL output frequency is adjustable from 3.5MHz to 100MHz.

15.4 Electrical Characteristics

Table 15-1 Clock Control System Electrical Characteristics

($V_{SYS} = V_{CC10} = 5V$, $V_{CC33} = 3.3V$, $V_{CC18} = 1.8V$, and $T_A = -40^{\circ}C$ to $105^{\circ}C$ unless otherwise specified.)

SYMBOL	PARAMETER	CONDITIONS	MIN	TYP	MAX	UNIT
Clock Tree (FRCLK, FCLK, HCLK, and ACLK)						
f_{FRCLK}	Free running clock frequency				50	MHz
f_{FCLK}	Fast clock frequency				100	MHz
f_{HCLK}	High-speed clock frequency				50	MHz
f_{ACLK}	Auxiliary clock frequency				100	MHz
Internal Oscillators						
f_{ROSC}	Ring oscillator frequency	Frequency setting = 11b		7.5		MHz
		Frequency setting = 10b		9.6		
		Frequency setting = 01b		13.8		
		Frequency setting = 00b		25.7		
f_{TRIM}	Trimmed RC oscillator frequency	$T_A = 25^{\circ}C$	-2%	4	2%	MHz
		$T_A = -40^{\circ}C$ to $105^{\circ}C$	-3%	4	3%	
	Trimmed RC oscillator clock jitter	$T_A = -40^{\circ}C$ to $85^{\circ}C$		0.5		%
Crystal Oscillator Driver						
$V_{IH;XIN}$	XIN high-level input voltage		$0.65 \cdot V_{CC18}$			V
$V_{IL;XIN}$	XIN low-level input voltage				$0.35 \cdot V_{CC18}$	V
f_{XTAL}	Crystal oscillator frequency range		2		10	MHz
	Recommended capacitive load	$f_{XTAL} = 2MHz$ to $3MHz$		25		pF
		$f_{XTAL} = 3MHz$ to $6MHz$		20		
		$f_{XTAL} = 6MHz$ to $10MHz$		16		
	External circuit ESR	$f_{XTAL} = 2MHz$ to $3MHz$			1000	Ω
		$f_{XTAL} = 3MHz$ to $6MHz$			400	
		$f_{XTAL} = 6MHz$ to $10MHz$			100	
External Clock Input						
f_{EXTCLK}	External clock input frequency range				40	MHz
$t_{HIGH;EXTCLK}$	External clock high time		10			ns
$t_{LOW;EXTCLK}$	External clock low time		10			ns
PLL						
f_{INPLL}	PLL input frequency range		2		25	MHz
f_{OUTPLL}	PLL output frequency range		3.5		100	MHz
	PLL settling time			0.5		ms
	PLL period jitter	RMS		30		ps
		Peak to peak		± 150		

16 ARM® CORTEX®-M0 MICROCONTROLLER CORE

16.1 Features

- Arm® Cortex®-M0 core
- Fast single-cycle 32-bit x 32-bit multiplier
- 24-bit SysTick timer
- Up to 50MHz operation
- Serial wire debug (SWD), with 4 break-point and 2 watch-point unit comparators
- Nested vectored interrupt controller (NVIC) with 25 external interrupts
- Wake-up interrupt controller (WIC) with GPIO, real-time clock (RTC) and watchdog timer (WDT) interrupts enabled
- Sleep and deep-sleep mode with clock gating

16.2 Block Diagram

Figure 16-1 Arm Cortex-M0 Microcontroller Core

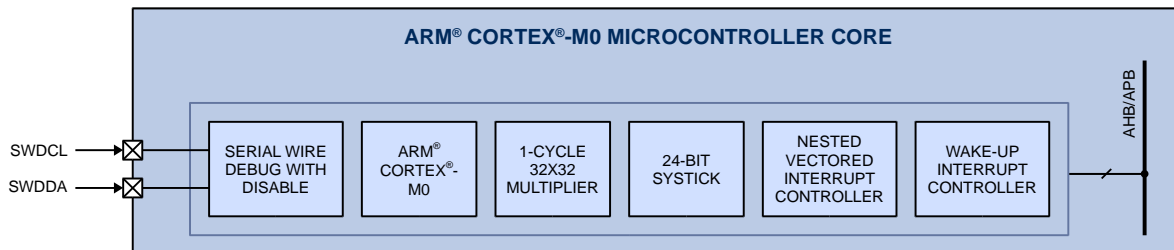

16.3 Functional Description

The Arm® Cortex®-M0 microcontroller core is configured for little endian operation and includes the fast single-cycle 32-bit multiplier and 24-bit SysTick timer and can operate at a frequency of up to 50MHz.

The microcontroller nested vectored interrupt controller (NVIC) supports 25 external interrupts for the device's peripherals and sub-systems. For low-latency interrupt processing, the NVIC also supports interrupt tail-chaining. The wake-up interrupt controller (WIC) is able to wake up the device from low-power modes using any GPIO interrupt, as well as from the RTC or WDT. The Arm® Cortex®-M0 supports both sleep and deep-sleep low-power modes. The deep-sleep mode supports clock gating to limit standby power even further.

Firmware debug support includes 4 break-point and 2 watch-point unit comparators using the serial wire debug (SWD) protocol. The serial wire debug mechanism can be disabled to prevent device access to the firmware in the field.

16.4 Electrical Characteristics

Table 16-1 Microcontroller and Clock Control System Electrical Characteristics

(V_{sys} = V_{CC10} = 5V, V_{CC33} = 3.3V, V_{CC18} = 1.8V, and T_A = -40°C to 105°C unless otherwise specified.)

SYMBOL	PARAMETER	CONDITIONS	MIN	TYP	MAX	UNIT
f _{HCLK}	Microcontroller clock	HCLK			50	MHz
I _{OP;V_{SYS}}	V _{sys} operating supply current	f _{FRCLK} = f _{HCLK} = f _{ACLK} = ROSC 11b, PLL disabled, CPU halt; other clock sources, ADC, timers, and serial interface disabled	2.5 ⁽¹⁾	3.4	7	mA
		f _{FRCLK} = f _{HCLK} = f _{ACLK} = ROSC 10, PLL disabled, CPU halt; other clock sources, ADC, timers, and serial interface disabled	3.0 ⁽¹⁾	4	7.8	
		f _{FRCLK} = f _{HCLK} = f _{ACLK} = ROSC 01, PLL disabled, CPU halt; other clock sources, ADC, timers, and serial interface disabled	4.1 ⁽¹⁾	5.3	9.5	
		f _{FRCLK} = f _{HCLK} = f _{ACLK} = ROSC 00, PLL disabled, CPU halt; other clock sources, ADC, timers, and serial interface disabled	7.4 ⁽¹⁾	9	15	
		f _{FRCLK} = f _{HCLK} = f _{ACLK} = CLKREF, PLL disabled, CPU halt; other clock sources, ADC, timers, and serial interface disabled	1.5 ⁽¹⁾	2.3	4.4	
		f _{FRCLK} = f _{HCLK} = f _{ACLK} = 10MHz XTAL, PLL disabled, CPU halt; other clock sources, ADC, timers, and serial interface disabled	3.6 ⁽¹⁾	4.5	6.7	
		f _{FRCLK} = 4MHz CLKREF, f _{HCLK} = 50MHz, f _{ACLK} = f _{OUTPLL} = 100MHz, CPU halt; other clock sources, ADC, timers, and serial interface disabled	20.9 ⁽¹⁾	23.3	26.5	
I _{Q;V_{CC10}}	V _{CC10} quiescent supply current			0.02		mA

⁽¹⁾ All minimum operating supply current values are for room temperature only

16.5 Typical Performance Characteristics

(V_{sys} = V_{CC10} = 5V, V_{CC33} = 3.3V, V_{CC18} = 1.8V, and T_A = 25°C unless otherwise specified.)

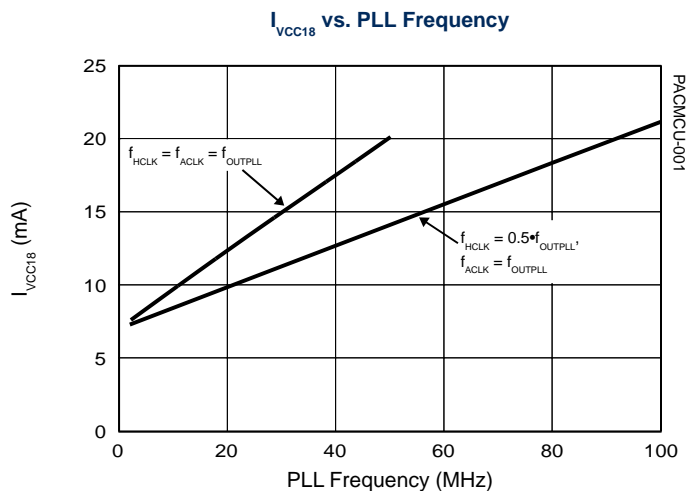

17 I/O CONTROLLER

17.1 Features

- 5V-compliant I/O PAX, PDx, PEx
- 3.3V-compliant I/O PCx
- Configurable drive strength on PAX, PDx, PEx
- Configurable pull-up or pull-down on PAX, PDx, PEx

17.2 Block Diagram

Figure 17-1 I/O controller

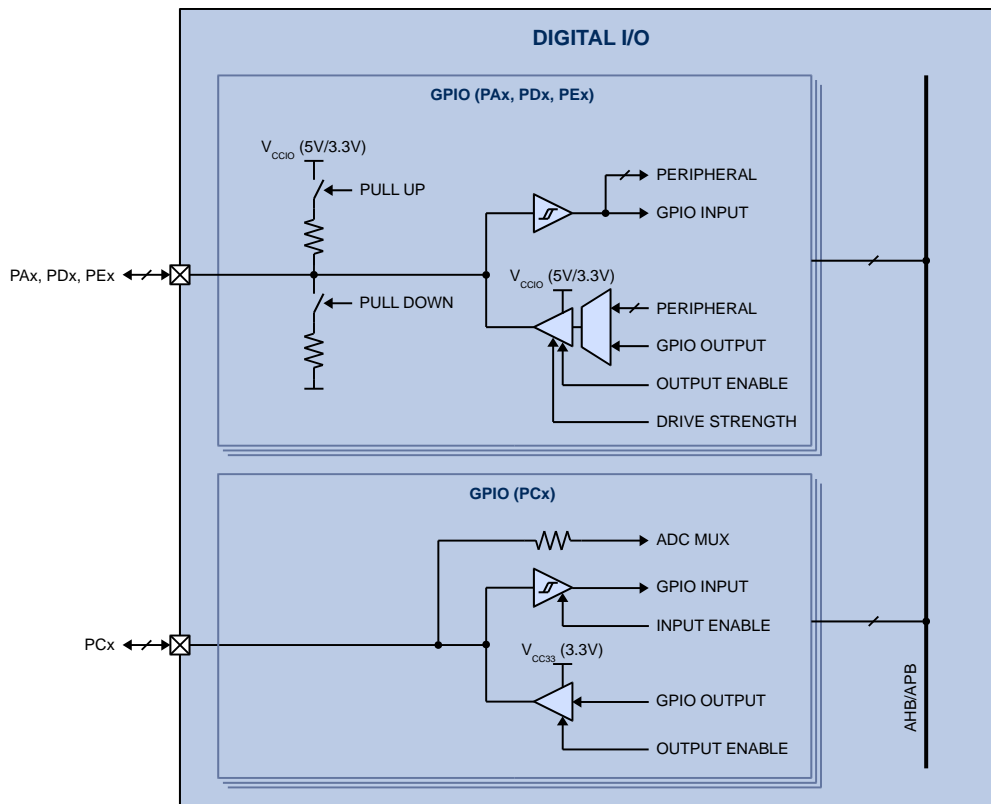

17.3 Functional Description

The PAC can support up to 4 ports with 8 I/Os each from PAX, PCx, PDx, and PEx, in addition to the I/Os on the analog front end. All PAX, PCx, PDx, and PEx ports have interrupt capability with configurable interrupt edge.

PAX, PDx, and PEx I/Os use V_{CCIO} as the I/O supply voltage that is 5V on default parts (and 3.3V available from factory). The drive current can be configured as 8mA or 16mA. They also support weak pull-up and pull-down to save external components.

PCx uses V_{CC33} as its I/O supply voltage. The drive current is fixed to 8mA. PC0 to PC5 are also associated with analog inputs AD0 to AD5 to the ADC.

17.4 GPIO Current Injection

Under normal operation, there should not be current injected into the GPIOs on the device due to the GPIO voltage below ground or above the GPIO supply.³ Current injected occurs when the GPIO pin voltage is less than -0.3V or when greater than GPIO supply + 0.3V.

In order provide a robust solution when this situation occurs, this device allows a small amount of injected current into the GPIO pins, to avoid excessive leakage or device damage.

For information on the GPIO current injection thresholds, see the absolute maximum parameters for this device.

Sustained operation with the GPIO pin voltage greater than the GPIO supply or when the GPIO pin voltage is less than -0.3V may result in reduced lifetime of the device. GPIO current injection should only be a temporary condition.

³ VCC33 is the supply for any PC GPIO pin and VCCIO is the supply for any other GPIO pins.

17.5 Electrical Characteristics

Table 17-1 I/O Controller Electrical Characteristics

($V_{SYS} = V_{CCIO} = 5V$, $V_{CC33} = 3.3V$, $V_{CC18} = 1.8V$, and $T_A = -40^{\circ}C$ to $105^{\circ}C$ unless otherwise specified.)

SYMBOL	PARAMETER	CONDITIONS	MIN	TYP	MAX	UNIT
PAX, PDx, PEx (5V Operation)						
V_{IH}	High-level input voltage	$V_{CCIO} = 5V$	3			V
V_{IL}	Low-level input voltage	$V_{CCIO} = 5V$			0.8	V
I_{OL}	Low-level output sink current	$V_{CCIO} = 5V$, $V_{OL} = 0.4V$	Drive strength setting = 0b	7		mA
			Drive strength setting = 1b	15		
I_{OH}	High-level output source current	$V_{CCIO} = 5V$, $V_{OH} = 2.4V$	Drive strength setting = 0b		-7	mA
			Drive strength setting = 1b		-15	
R_{PU}	Weak pull-up resistance	$V_{CCIO} = 5V$	53	66	87	k Ω
R_{PD}	Weak pull-down resistance	$V_{CCIO} = 5V$	63	108	244	k Ω
I_{IL}	Input leakage current	$T_A = 125^{\circ}C$	-10	0	10	μA
PAX, PDx, PEx (3.3V Operation)						
V_{IH}	High-level input voltage	$V_{CCIO} = 3.3V$	2			V
V_{IL}	Low-level input voltage	$V_{CCIO} = 3.3V$			0.8	V
I_{OL}	Low-level output sink current	$V_{CCIO} = 3.3V$, $V_{OL} = 0.4V$	Drive strength setting = 0b	4		mA
			Drive strength setting = 1b	8		
I_{OH}	High-level output source current	$V_{CCIO} = 3.3V$, $V_{OH} = 2.4V$	Drive strength setting = 0b		-4	mA
			Drive strength setting = 1b		-8	
R_{PU}	Weak pull-up resistance	$V_{CCIO} = 3.3V$	47	74	104	k Ω
R_{PD}	Weak pull-down resistance	$V_{CCIO} = 3.3V$	50	84	121	k Ω
I_{IL}	Input leakage current	$T_A = 125^{\circ}C$	-10	0	10	μA
PCx (3.3V Operation)						
V_{IH}	High-level input voltage	$V_{CC33} = 3.3V$	2			V
V_{IL}	Low-level input voltage	$V_{CC33} = 3.3V$			0.8	V
I_{OL}	Low-level output sink current	$V_{CC33} = 3.3V$, $V_{OL} = 0.4V$	7			mA
I_{OH}	High-level output source current	$V_{CC33} = 3.3V$, $V_{OH} = 2.4V$			-7	mA
I_{IL}	Input leakage current	$T_A = 125^{\circ}C$	-10	0	10	μA

18 SERIAL INTERFACE

18.1 Block Diagram

Figure 18-1 Serial Interface

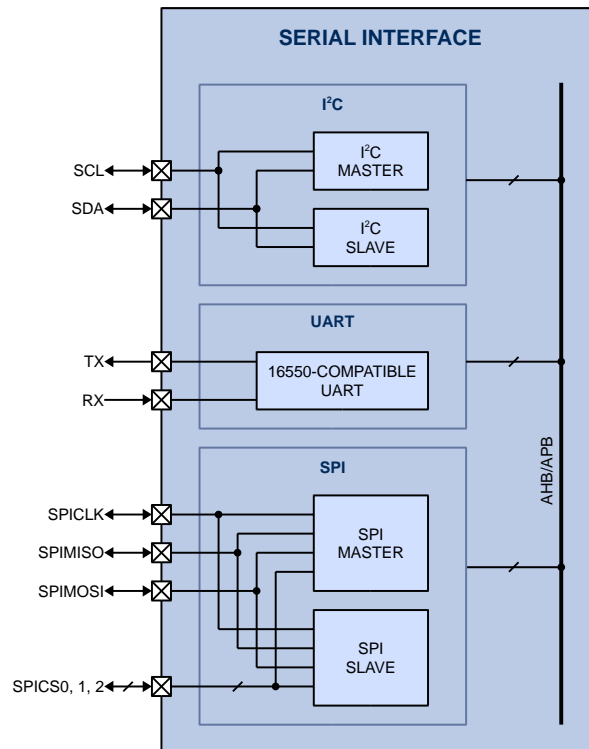

18.2 Functional Description

The device has up to three serial interfaces: I²C, UART, and SPI.

18.2.1 I²C Controller

The I²C controller is a configurable peripheral that can support various modes of operation:

- I²C master operation
 - ◆ Normal mode (100kHz), fast mode (400kHz), or fast mode plus (1MHz)
 - ◆ Single and multi-master
 - ◆ Synchronization (multi-master)
 - ◆ Arbitration (multi-master)
 - ◆ 7-bit or 10-bit slave addressing
- I²C slave operation
 - ◆ Normal mode (100kHz), fast mode (400kHz), or fast mode plus (1MHz)
 - ◆ Clock stretching
 - ◆ 7-bit or 10-bit slave addressing

The I²C peripheral may operate either by polling, or can be configured to be interrupt driven for both receive and transmit data.

18.3 UART Controller

The UART peripheral is a configurable peripheral that can support various features and modes of operation:

- Programmable clock selection
- National Instruments PC16550D compatible
- 16-deep transmit and receive FIFO and fractional clock divisor
- Up to 3.125Mbps communication speed (with HCLK = 50MHz)

The UART peripheral may operate either by polling, or can be configured to be interrupt driven for both receive and transmit data.

18.4 SPI Controller

The device contains an SPI controller that can each be used in either master or slave operation, with the following features:

- SPI master operation
 - ◆ Control of up to three different SPI slaves
 - ◆ Operation up to 25MHz
 - ◆ Flexible multiple transmit mode for variable-size SPI data with user-defined chip-select behavior
 - ◆ Chip select “shaping” through programmable additional delay for chip-select setup, hold and wait time for back-to-back transfers

- SPI master or slave operation
 - ◆ Supports clock phase and polarity control
 - ◆ Data transmission/reception can be on 8-, 16-, 24- or 32-bit boundary
 - ◆ Selectable data bit ordering (LSB or MSB first)
 - ◆ Programmable chip select polarity
 - ◆ Selectable “auto-retransmit” mode

The SPI peripheral may operate either by polling, or can be configured to be interrupt driven for both receive and transmit data.

18.5 Dynamic Characteristics

Table 18-1 Serial Interface Dynamic Characteristics

($V_{SYS} = V_{CCIO} = 5V$, $V_{CC33} = 3.3V$, $V_{CC18} = 1.8V$, and $T_A = -40^{\circ}C$ to $105^{\circ}C$ unless otherwise specified.)

SYMBOL	PARAMETER	CONDITIONS	MIN	TYP	MAX	UNIT
I²C						
f _{I2CCLK}	I ² C input clock frequency	Standard mode (100kHz)	2.8			MHz
		Fast mode (400kHz)	2.8			MHz
		Fast mode plus (1MHz)	6.14			MHz
UART						
f _{UARTCLK}	UART input clock frequency			f _{HCLK} /16		MHz
	UART baud rate	f _{HCLK} = 50MHz		3.125		Mbps
SPI						
f _{SPICLK}	SPI input clock frequency	Master mode		f _{HCLK} /2		MHz
		Slave mode		f _{HCLK} /2		MHz

Table 18-2 I²C Dynamic Characteristics

SYMBOL	PARAMETER	CONDITIONS	MIN	TYP	MAX	UNIT
f _{SCL}	SCL clock frequency	Standard mode	0		100	kHz
		Fast mode	0		400	
		Fast mode plus	0		1000	
t _{LOW}	SCL clock low	Standard mode	4.7			μs
		Fast mode	1.3			
		Fast mode plus	0.5			
t _{HIGH}	SCL clock high	Standard mode	4.0			μs
		Fast mode	0.6			
		Fast mode plus	0.26			
t _{HD;STA}	Hold time for a repeated START condition	Standard mode	4.0			μs
		Fast mode	0.6			
		Fast mode plus	0.26			
t _{SU;STA}	Set-up time for a repeated START condition	Standard mode	4.7			μs
		Fast mode	0.6			
		Fast mode plus	0.26			
t _{HD;DAT}	Data hold time	Standard mode	0		3.45	μs
		Fast mode	0		0.9	
		Fast mode plus	0			
t _{SU;DAT}	Data set-up time	Standard mode	250			ns
		Fast mode	100			
		Fast mode plus	50			
t _{SU;STO}	Set-up time for STOP condition	Standard mode	4.0			μs
		Fast mode	0.6			
		Fast mode plus	0.26			
t _{BUF}	Bus free time between a STOP and START condition	Standard mode	4.7			μs
		Fast mode	1.3			
		Fast mode plus	0.5			
t _r	Rise time for SDA and SCL	Standard mode			1000	ns
		Fast mode	20		300	
		Fast mode plus			120	
t _f	Fall time for SDA and SCL	Standard mode			300	ns
		Fast mode			300	
		Fast mode plus			120	
C _b	Capacitive load for each bus line	Standard mode, Fast mode			400	pF
		Fast mode plus			550	pF

Figure 18-2 I²C Timing Diagram

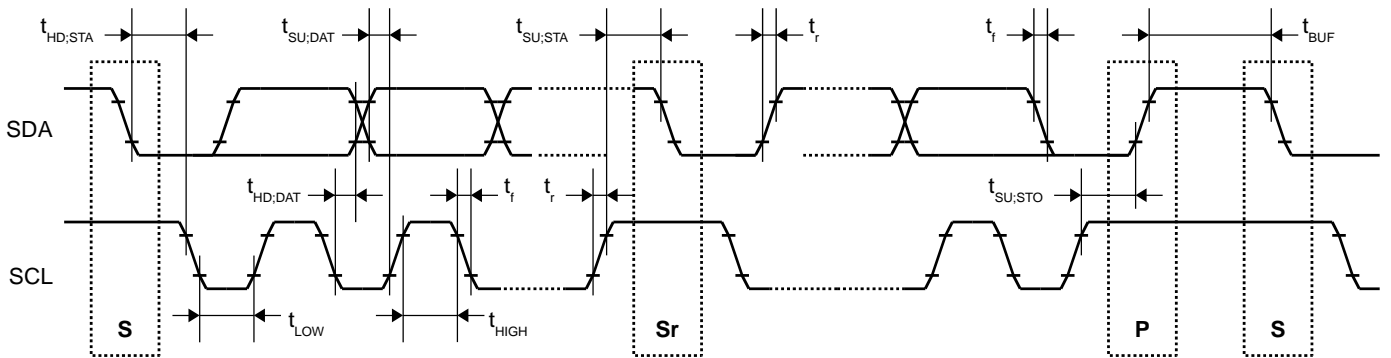
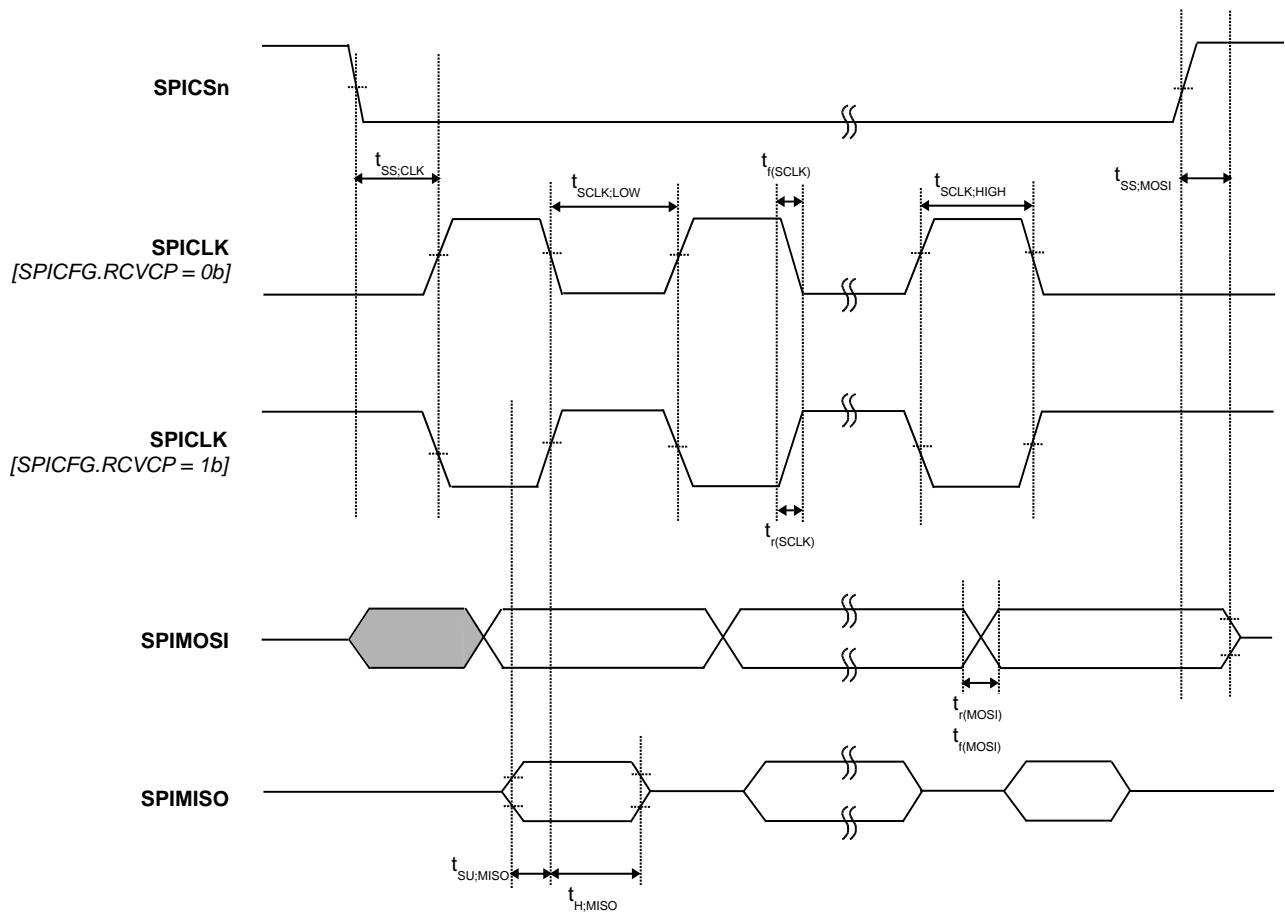

Table 18-3 SPI Dynamic Characteristics

SYMBOL	PARAMETER	CONDITIONS	MIN	TYP	MAX	UNIT
$t_{SCLK;HIGH}$	SPICLK Input High Time	SPICLK = 25MHz	30			ns
$t_{SCLK;LOW}$	SPICLK Input Low Time		30			ns
$t_{SS;SCLK}$	SPICSn to SPICLK Time		120			ns
$t_{SS;MOSI}$	SPICSn to SPIMISO High-impedance time		10		50	ns
$t_{r(SCLK)}$	SPICLK Rise Time			10	25	ns
$t_{f(SCLK)}$	SPICLK Fall Time			10	25	ns
$t_{r(MOSI)}$	SPIMISO Rise Time			10	25	ns
$t_{f(SMOSI)}$	SPIMISO Fall Time			10	25	ns
$t_{SU;MISO}$	SPIMISO Setup Time			20		ns
$t_{H;MISO}$	SPIMISO Hold Time			20		ns

Figure 18-3 SPI Timing Diagram



19 TIMERS

19.1 Block Diagram

Figure 19-1 Timers A, B, C, and D

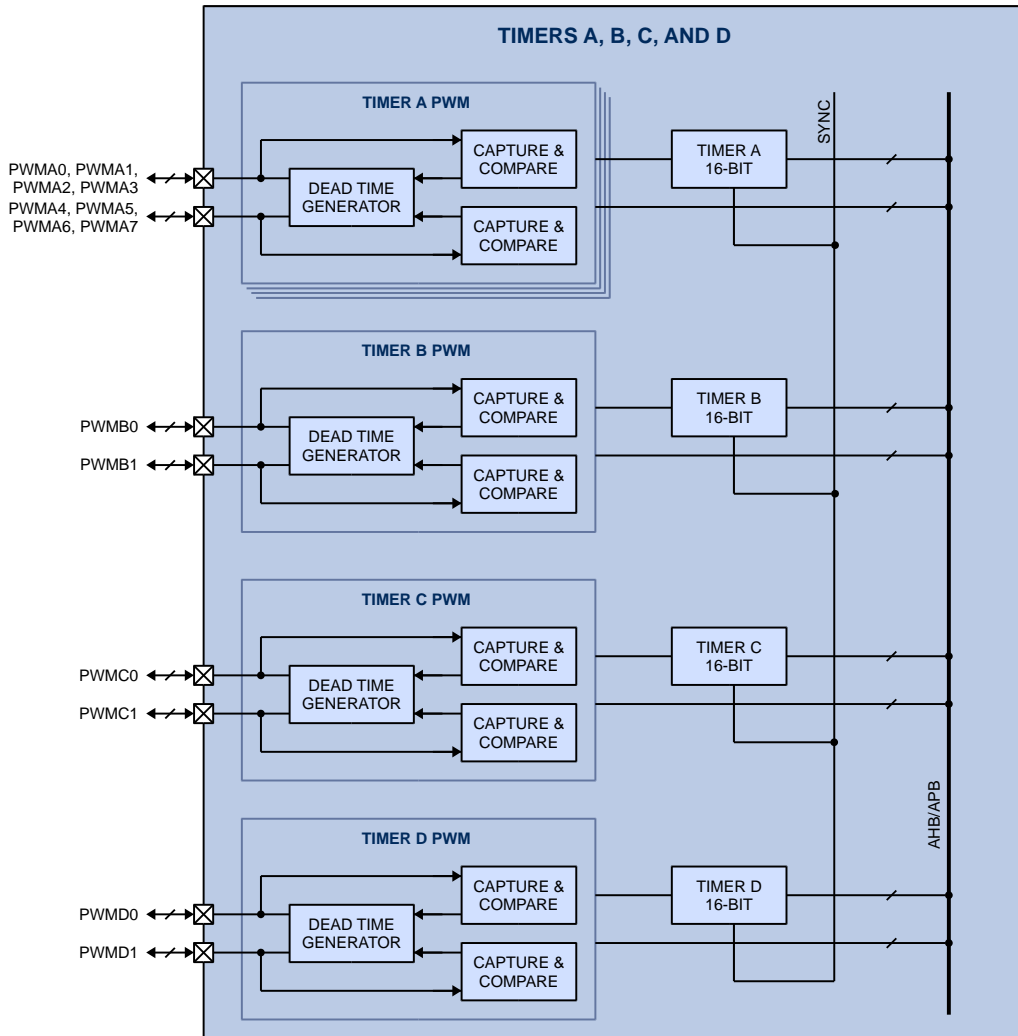

Figure 19-2 AFE Watchdog and Wake-Up Timer

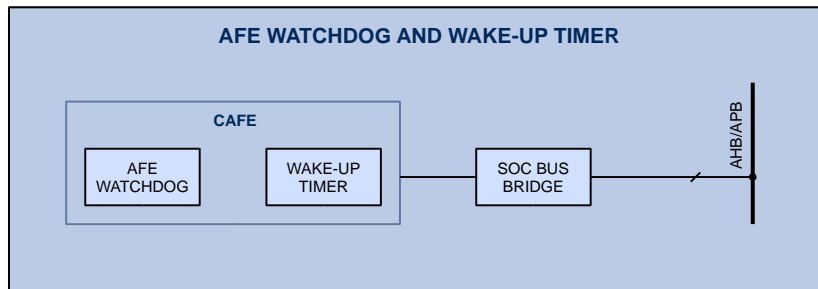
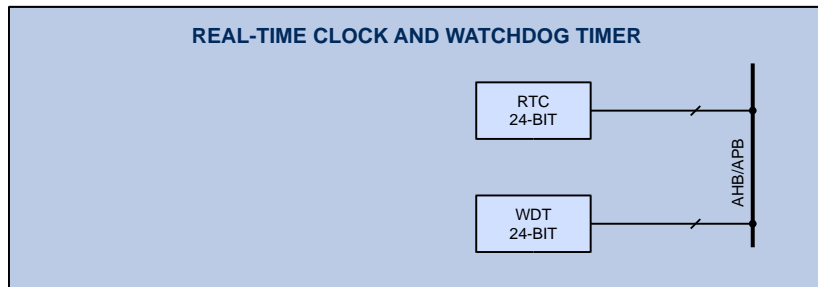

Figure 19-3 Real-Time Clock and Watchdog Timer



19.2 Functional Description

The device includes 9 timers: timer A, timer B, timer C, timer D, watchdog timer 1 (WDT), watchdog timer 2, wake-up timer, real-time clock (RTC), and SysTick timer. The device supports up to 14 different PWM signals and has up to 7 dead-time controllers. Timers A, B, C and D can be concatenated to synchronize to a single clock and start/stop signal for applications that require a synchronized timer period between timers.

19.2.1 Timer A

Timer A is a general purpose 16-bit timer with 8 PWM/capture and compare units. It has 4 pairs of PWM signals going into 4 dead-time controllers. Timer A can be concatenated with timers B, C, and D to synchronize the PWM/capture and compare units. It can use either ACLK or HCLK as clock input with an additional clock divider from /1 to /128.

19.2.2 Timer B

Timer B is a general purpose 16-bit timer with 2 PWM/capture and compare units. It has one pair of PWM signals going into one dead-time controller, as well as 2 additional compare units that can be used for additional system time bases for interrupts. Timer B can be concatenated with timers A, C, and D to synchronize the PWM/capture and compare units. It can use either ACLK or HCLK as clock input with an additional clock divider from /1 to /128.

19.2.3 Timer C

Timer C is a general purpose 16-bit timer with 2 PWM/capture and compare units. It has one pair of PWM signals going into one dead-time controller. Timer C can be concatenated with timers A, B, and D to synchronize the PWM/capture and compare units. It can use either ACLK or HCLK as clock input with an additional clock divider from /1 to /128.

19.2.4 Timer D

Timer D is a general purpose 16-bit timer with 2 PWM/capture and compare units. It has one pair of PWM signals going into one dead-time controller. Timer D can be concatenated with timers A, B, and C to synchronize the PWM/capture and compare units. It can use either ACLK or HCLK as clock input with an additional clock divider from /1 to /128.

19.2.5 Watchdog Timer

The 24-bit watchdog timer (WDT) can be used for long time period measurements or periodic wake up from sleep mode. The watchdog timer can be used as a system watchdog, or as an interval timer, or both. The watchdog timer can use either FRCLK or FCLK as clock input with an additional clock divider from /2 to /65536.

19.2.6 CAFE Watchdog Timer

There is a second watchdog timer in the AFE that can be used to monitor communication between the MCU and AFE on the PAC SOC bus. If this timer expires, it will trigger a device reset when there is no communication for a period of either 4s or 8s.

19.2.7 Wake-Up Timer

The wake-up timer can be used for very low power hibernate and sleep modes to wake up the micro controller periodically. It can be configured to be 125ms, 250ms, 500ms, 1s, 2s, 4, or 8s.

19.2.8 Real-Time Clock

The 24-bit real-time clock (RTC) can be used for time measurements when an accurate clock source is used. This timer can also be used for periodic wake up from sleep mode. The RTC uses FRCLK as clock input with an additional clock divider from /2 to /65536.

20 THERMAL CHARACTERISTICS

Table 20-1 Thermal Characteristics

PARAMETER	VALUE	UNIT
Operating ambient temperature range	-40 to 105	°C
Operating junction temperature range	-40 to 125	°C
Storage temperature range	-55 to 150	°C
Lead temperature (Soldering, 10 seconds)	300	°C
Junction-to-case thermal resistance (θ_{JC})	16.8	°C/W
Junction-to-ambient thermal resistance (θ_{JA})	31.5	°C/W

21 APPLICATION EXAMPLES

The following simplified diagrams show different examples of PAC applications. Refer to application notes for detailed design description.

Figure 21-1 3-Phase Motor Drive Using PAC5255 (Simplified Diagram)

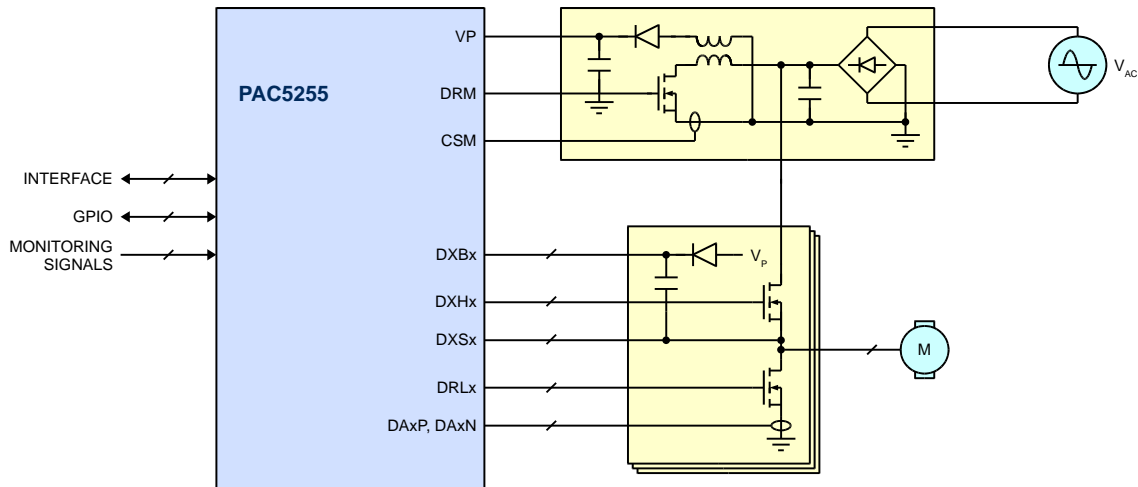

Figure 21-2 Solar Micro-Inverter Using PAC5255 (Simplified Diagram)

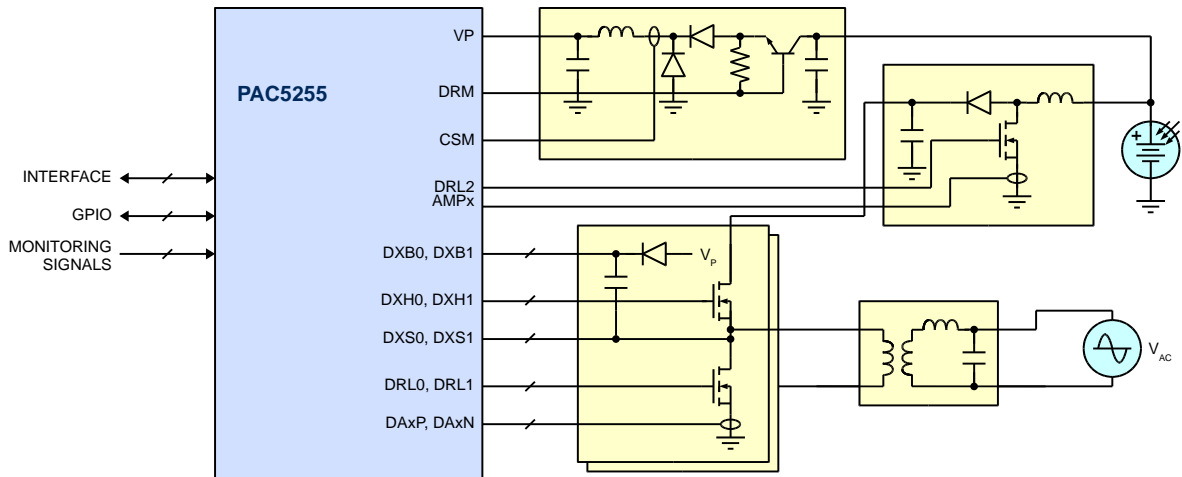
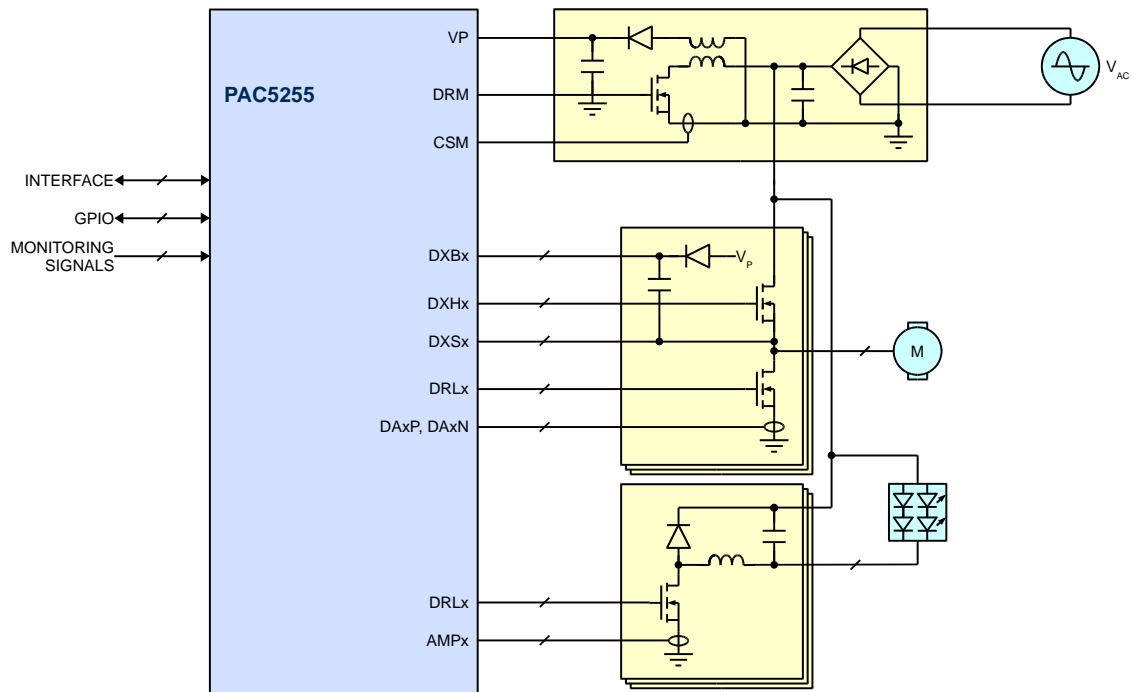

Figure 21-3 Motor with LED Lighting Using PAC5255 (Simplified Diagram)



22 PACKAGE OUTLINE AND DIMENSIONS

22.1 TQFN1010-57 Package Outline and Dimensions

Figure 22-1 TQFN1010-57

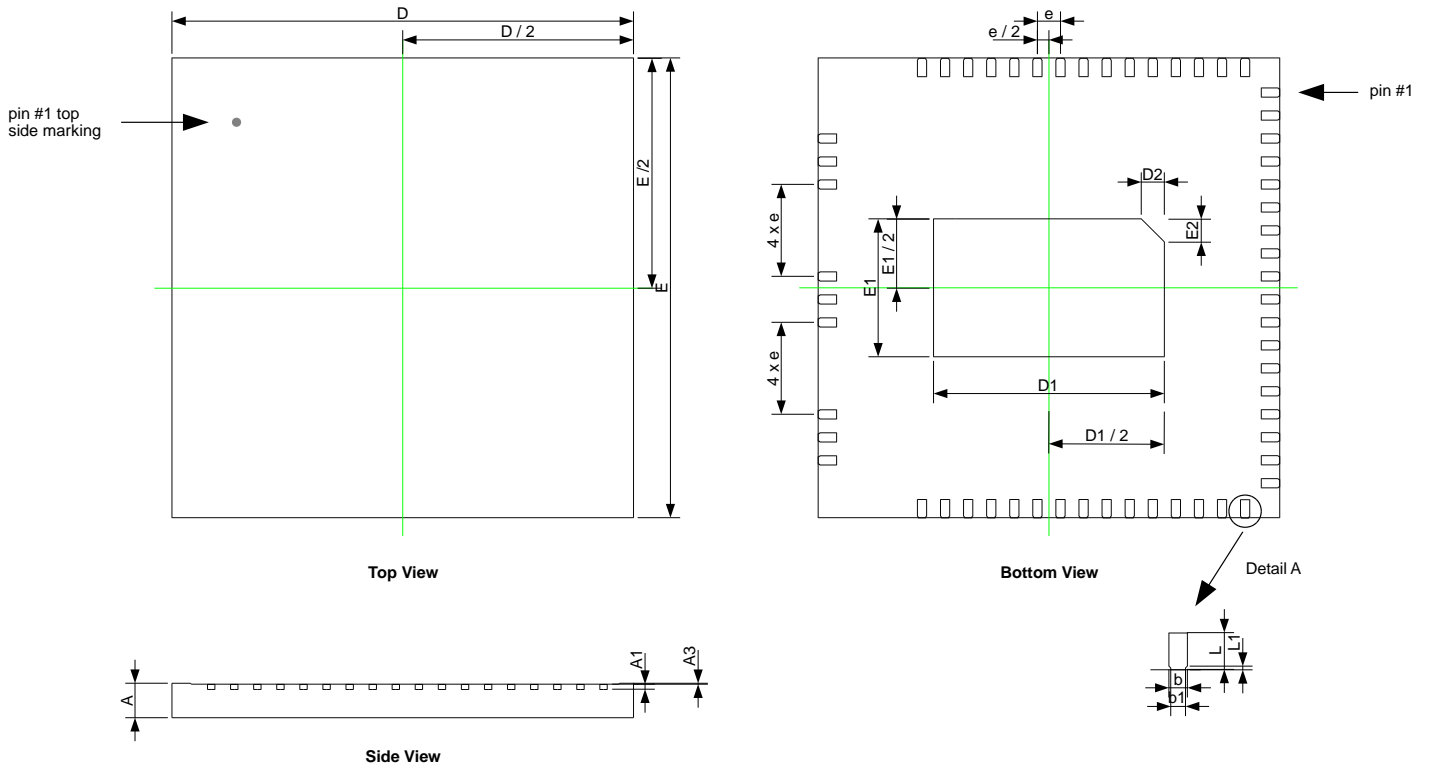

Table 22-1 Dimensions

Dimensions	Millimeters		Inches	
	Minimum	Maximum	Minimum	Maximum
A	0.700	0.800	0.028	0.031
A1	-0.004	0.050	0.000	0.002
A3	0.203		0.008	
b	0.150	0.250	0.006	0.010
b1	0.100	0.200	0.004	0.008
D	9.900	10.100	0.390	0.398
D1	4.900	5.100	0.193	0.201
E	9.900	10.100	0.390	0.398
E1	2.900	3.100	0.114	0.122
e	0.500		0.020	
L	0.350	0.450	0.014	0.018

Product Compliance

This part complies with RoHS directive 2011/65/EU as amended by (EU) 2015/863.

This part also has the following attributes:

- Lead Free
- Halogen Free (Chlorine, Bromine)



Contact Information

For the latest specifications, additional product information, worldwide sales and distribution locations:

Web: www.qorvo.com

Tel: 1-844-890-8163

Email: customer.support@qorvo.com

For technical questions and application information:

Email: appsupport@qorvo.com

Important Notice

The information contained herein is believed to be reliable; however, Qorvo makes no warranties regarding the information contained herein and assumes no responsibility or liability whatsoever for the use of the information contained herein. All information contained herein is subject to change without notice. Customers should obtain and verify the latest relevant information before placing orders for Qorvo products. The information contained herein or any use of such information does not grant, explicitly or implicitly, to any party any patent rights, licenses, or any other intellectual property rights, whether with regard to such information itself or anything described by such information. **THIS INFORMATION DOES NOT CONSTITUTE A WARRANTY WITH RESPECT TO THE PRODUCTS DESCRIBED HEREIN, AND QORVO HEREBY DISCLAIMS ANY AND ALL WARRANTIES WITH RESPECT TO SUCH PRODUCTS WHETHER EXPRESS OR IMPLIED BY LAW, COURSE OF DEALING, COURSE OF PERFORMANCE, USAGE OF TRADE OR OTHERWISE, INCLUDING THE IMPLIED WARRANTIES OF MERCHANTABILITY AND FITNESS FOR A PARTICULAR PURPOSE.**

Without limiting the generality of the foregoing, Qorvo products are not warranted or authorized for use as critical components in medical, life-saving, or life-sustaining applications, or other applications where a failure would reasonably be expected to cause severe personal injury or death.

Copyright 2019 © Qorvo, Inc. | Qorvo®, Active-Semi®, Power Application Controller®, Multi-Mode Power Manager™, Configurable Analog Front End™ and Application Specific Power Drivers™ are trademarks of Qorvo, Inc.

Arm® and Cortex® are registered trademarks of Arm Limited. All referenced brands and trademarks are the property of their respective owners.