

Revision			
Rev.	Description	Date	Approved

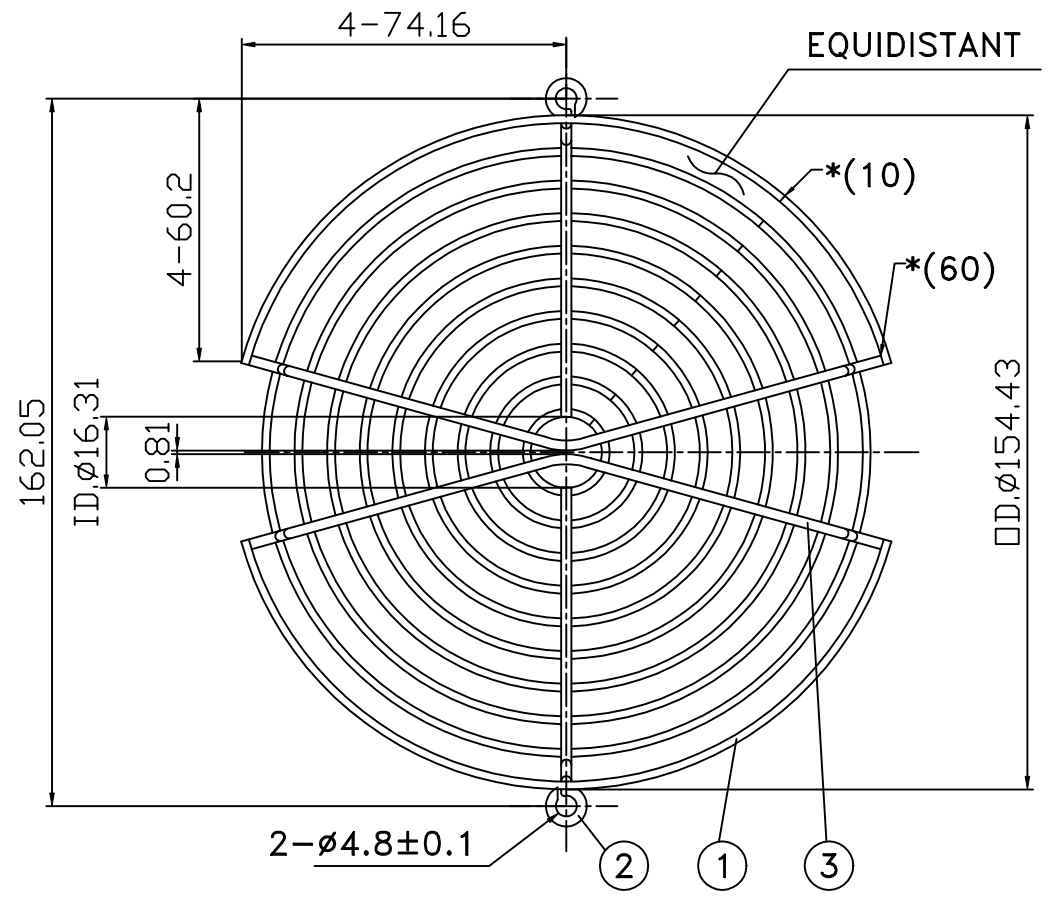

- NOTES:
- 1.MATERIAL:SAE 1008(OR EQUIVALENT)
BRIGHT BASIC WIRE
 - 2.FINISH:BRIGHT NICKEL-CHROME PLATING.
 3. 0.35±0.05 DEPTH OF SERRATIONS ON WIRE.
 - 4.WELD JOINTS TO WITHSTAND 70 LBS PULL FORCE.
 - 5.RING: ø1.8; RIB: ø2.3.
 - 6.GENERAL TOLERANCE UNLESS NOTED IS ±015*** & ±030**
 7. RoHS Complaint

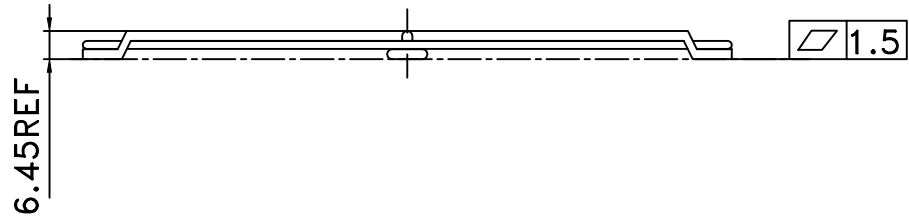

Dim range (mm)	Tolerance +/- (mm)	Qualtek Electronics Corp. FAN-S DIVISION		
		Part Number: 08125		RoHS Compliant
<=6	0.24	Description: FAN GUARD		
6-18	0.35	UNIT: mm	Rev A	
18-50	0.50	Drawn/Date	Checked/Date	Approved/Date
50-120	0.70	B.ZHANG	PC/03-08-05	JJH/03-08-05
120-250	0.93	03-08-05		
250-400	1.15			
400-630	1.40			
>630	1.50			