150mA VOLTAGE REGULATOR (Wide Input Voltage Range)

NO.EA-152-111026

OUTLINE

The R1514x series are CMOS-based positive voltage regulator (VR) ICs featuring 150mA output current. The R1514xxxxB has features of high input voltage and ultra-low supply current. A peak current limit circuit, a short current limit circuit, and a thermal shutdown circuit are built in the R1514x series.

The operating temperature is -40°C to 105°C and the maximum input voltage is 36V, the R1514x series are very suitable for power source of car accessories.

The regulator output voltage is fixed in the R1514xxxxB and can be selected with a step of 0.1V in the range of 2.0V to 12.0V. Output voltage accuracy is $\pm 2\%$.

The packages for these ICs are the SOT-89-5 for space saving and the HSOP-6J for higher power applications.

FEATURES

- Input Voltage Max. 36V
- Supply Current Typ. $9\mu\text{A}$
- Standby Current Typ. $0.1\mu\text{A}$
- Temperature-Drift Coefficient of Output Voltage ... Typ. $\pm 100\text{ppm}/^{\circ}\text{C}$
- Output Current Min. 150mA ($V_{\text{IN}}=V_{\text{OUT}}+3.0\text{V}$; R1514x050B)
- Line Regulation Typ. 0.05%/V
- Output Voltage Accuracy..... $\pm 2\%$
- Output Voltage Range..... 2.0V to 12.0V (0.1V steps)
(For other voltages, please refer to MARK INFORMATION.)
- Packages SOT-89-5, HSOP-6J
- Built-in Peak Current Limit Circuit
- Built-in Short Current Limit Circuit
- Built-in Thermal Shutdown Circuit
- Operating Temperature -40°C to 105°C

APPLICATIONS

- Power source for home appliances such as refrigerators, rice cookers, electric water warmers, etc.
- Power source for car audio equipment, car navigation system, ETC system, etc.
- Power source for notebook PCs, digital TVs, cordless phones, and private LAN system, etc.
- Power source for office equipment machines such as copiers, printers, facsimiles, scanners, projectors, etc.

BLOCK DIAGRAM

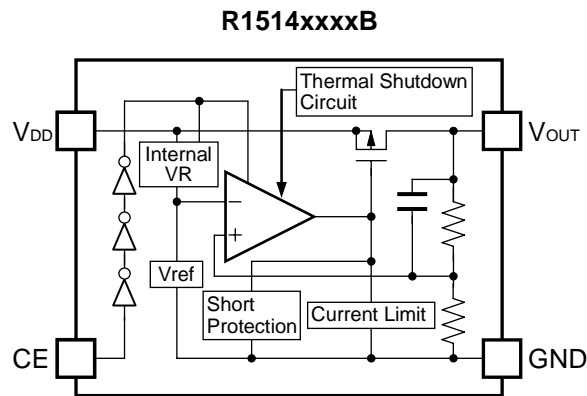

SELECTION GUIDE

The output voltage, package for the ICs can be selected at the user's request.

Product Name	Package	Quantity per Reel	Pb Free	Halogen Free
R1514HxxxB-T1-FE	SOT-89-5	1,000 pcs	Yes	Yes
R1514SxxxB-E2-FE	HSOP-6J	1,000 pcs	Yes	Yes

xxx : The output voltage can be designated in the range of 2.0V(020) to 12.0V(120) in 0.1V steps.
(For other voltages, please refer to MARK INFORMATIONS.)

PIN CONFIGURATIONS



PIN DESCRIPTIONS

• SOT-89-5

Pin No.	Symbol	Description
1	V_{OUT}	Output Pin
2	GND*	Ground Pin
3	CE	Chip Enable Pin ("H" Active)
4	GND*	Ground Pin
5	V_{DD}	Input Pin

*) The GND pin must be wired together when it is mounted on board.

• HSOP-6J

Pin No.	Symbol	Description
1	V_{OUT}	Output Pin
2	GND*	Ground Pin
3	CE	Chip Enable Pin ("H" Active)
4	GND*	Ground Pin
5	GND*	Ground Pin
6	V_{DD}	Input Pin

*) The GND pin must be wired together when it is mounted on board.

ABSOLUTE MAXIMUM RATINGS

Symbol	Item	Rating	Unit
V_{IN}	Input Voltage	-0.3 to 50	V
V_{IN}	Peak Input Voltage *1	60	V
V_{CE}	Input Voltage (CE Pin)	-0.3 to $V_{IN}+0.3 \leq 50$	V
V_{OUT}	Output Voltage	-0.3 to $V_{IN}+0.3 \leq 50$	V
I_{OUT}	Output Current	250	mA
P_D	Power Dissipation (SOT-89-5) *2	900	mW
	Power Dissipation (HSOP-6J) *2	1700	
T_{opt}	Operating Temperature Range	-40 to 105	°C
T_{stg}	Storage Temperature Range	-55 to 125	°C

*1) Duration time=200ms

*2) For Power Dissipation, please refer to PACKAGE INFORMATION.

ABSOLUTE MAXIMUM RATINGS

Electronic and mechanical stress momentarily exceeded absolute maximum ratings may cause the permanent damages and may degrade the life time and safety for both device and system using the device in the field.

The functional operation at or over these absolute maximum ratings is not assured.

RECOMMENDED OPERATING CONDITIONS (ELECTRICAL CHARACTERISTICS)

All of electronic equipment should be designed that the mounted semiconductor devices operate within the recommended operating conditions. The semiconductor devices cannot operate normally over the recommended operating conditions, even if when they are used over such conditions by momentary electronic noise or surge. And the semiconductor devices may receive serious damage when they continue to operate over the recommended operating conditions.

ELECTRICAL CHARACTERISTICS

• R1514xxxxB

T_{opt}=25°C

Symbol	Item	Conditions	Min.	Typ.	Max.	Unit
V _{IN}	Input Voltage		4		36	V
I _{SS}	Supply Current	V _{IN} =V _{OUT} +3.0V, I _{OUT} =0mA		9	20	μA
I _{standby}	Standby Current	V _{IN} =36V, V _{CE} =0V		0.1	1.0	μA
V _{OUT}	Output Voltage	V _{IN} =V _{OUT} +3.0V, I _{OUT} =1mA	×0.98		×1.02	V
I _{OUT}	Output Current	V _{IN} =V _{OUT} +3.0V	Refer to the following table			
ΔV _{OUT} /ΔI _{OUT}	Load Regulation	V _{IN} =V _{OUT} +3.0V, 1mA ≤ I _{OUT} ≤ 40mA	Refer to the following table			
ΔV _{OUT} /ΔV _{IN}	Line Regulation	V _{OUT} +1.5V ≤ V _{IN} ≤ 36V, I _{OUT} =1mA		0.05	0.20	%/V
V _{DIF}	Dropout Voltage	I _{OUT} =20mA	Refer to the following table			
ΔV _{OUT} /ΔT _{opt}	Output Voltage Temperature Coefficient	V _{IN} =V _{OUT} +3.0V, I _{OUT} =1mA −40°C ≤ T _{opt} ≤ 105°C		±100		ppm/°C
I _{SC}	Short Current Limit	V _{OUT} =0V		50		mA
V _{CEH}	CE Input Voltage "H"		1.5		V _{IN}	V
V _{CEL}	CE Input Voltage "L"		0		0.3	V
T _{TSD}	Thermal Shutdown Temperature	Junction Temperature		150		°C
T _{TSR}	Thermal Shutdown Released Temperature	Junction Temperature		125		°C

• Output Current by Output Voltage

T_{opt}=25°C

Output Voltage V _{OUT} (V)	Output Current I _{OUT} (mA)	
	Conditions	Min.
2.0 ≤ V _{OUT} < 3.0	V _{IN} =V _{OUT} +3.0V	100
3.0 ≤ V _{OUT} < 5.0		120
5.0 ≤ V _{OUT} ≤ 12.0		150

• Dropout Voltage by Output Voltage

T_{opt}=25°C

Output Voltage V _{OUT} (V)	Dropout Voltage V _{DIF} (V)			
	Conditions	Typ.	Max.	
V _{OUT} =2.0	I _{OUT} =20mA		2.0	
V _{OUT} =2.1			1.9	
V _{OUT} =2.2			1.8	
V _{OUT} =2.3			1.7	
V _{OUT} =2.4			1.6	
V _{OUT} =2.5			1.5	
V _{OUT} =2.6			1.4	
V _{OUT} =2.7			1.3	
V _{OUT} =2.8			1.2	
V _{OUT} =2.9			1.1	
V _{OUT} =3.0			1.0	
V _{OUT} =3.1			0.9	
V _{OUT} =3.2			0.8	
V _{OUT} =3.3			0.7	
V _{OUT} =3.4			0.6	
V _{OUT} =3.5			0.5	
V _{OUT} =3.6			0.4	
3.7 ≤ V _{OUT} < 4.0			0.35	0.60
4.0 ≤ V _{OUT} < 5.0			0.25	0.40
5.0 ≤ V _{OUT} ≤ 12.0			0.20	0.35

• Load Regulation by Output Voltage

T_{opt}=25°C

Output Voltage V _{OUT} (V)	Load Regulation ΔV _{OUT} /ΔI _{OUT} (mV)		
	Conditions	Typ.	Max.
2.0 ≤ V _{OUT} < 5.0	V _{IN} =V _{OUT} +3.0V	10	25
5.0 ≤ V _{OUT} ≤ 12.0	1mA ≤ I _{OUT} ≤ 40mA	20	35

TYPICAL APPLICATION

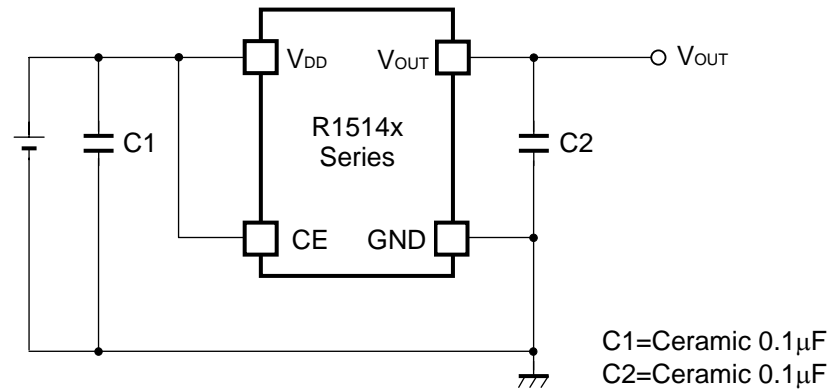

TECHNICAL NOTES

When using these ICs, consider the following points:

Phase Compensation

Phase Compensation of the R1514x Series has been made internally for stable operation even though the load current would vary. Therefore, without the capacitors, C1 and C2, the output voltage is regulated, however, for more stable operation, use capacitors as C1 and C2. Especially, if the input line is long and impedance is high, C1 is necessary. Moreover, if you use rather large C2, transient response will be improved. Recommended value is in the range from 0.1µF to 10µF. Wiring should be made as short as possible.

Connect the capacitor, C1 between V_{DD} pin and GND pin and C2 between V_{OUT} and GND as close as possible.

GND wiring of mounting on board

No.2 pin and No.4 pin of SOT-89-5 package must be wired to the GND plane. No.2 pin, No.4 pin and No.5 pin of HSOP-6J package must be wired to the GND plane when it is mounted on board.

Thermal Shutdown

Thermal shutdown function is included in the R1514x Series, if the junction temperature is equal or more than +150°C(Typ.), the operation of regulator would stop. After that, when the junction temperature is equal or less than +125°C(Typ.), the operation of regulator would restart. Unless the cause of rising temperature would remove, the regulator repeats on and off, and output waveform would be like consecutive pulses.

Chip Enable Circuit

Do not make voltage level of chip enable pin keep floating level, or in between V_{CEH} and V_{CEL}. Otherwise, the output voltage would be unstable or indefinite, or unexpected current would flow internally.

TEST CIRCUITS

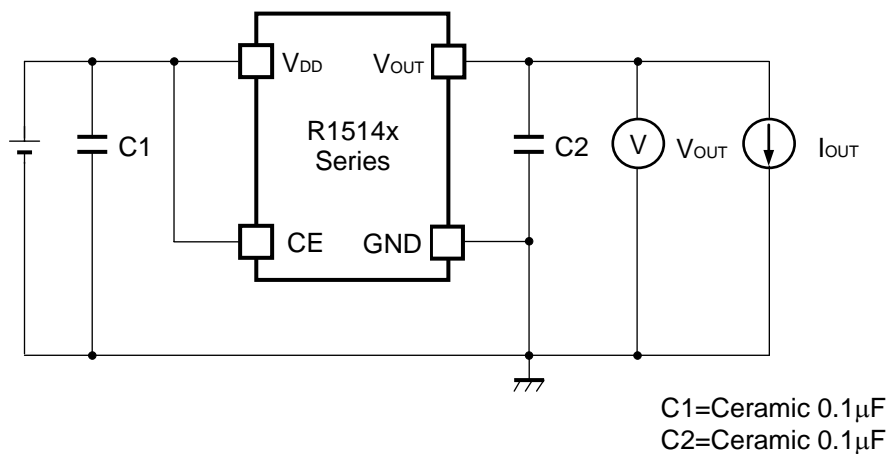

Basic Test Circuit

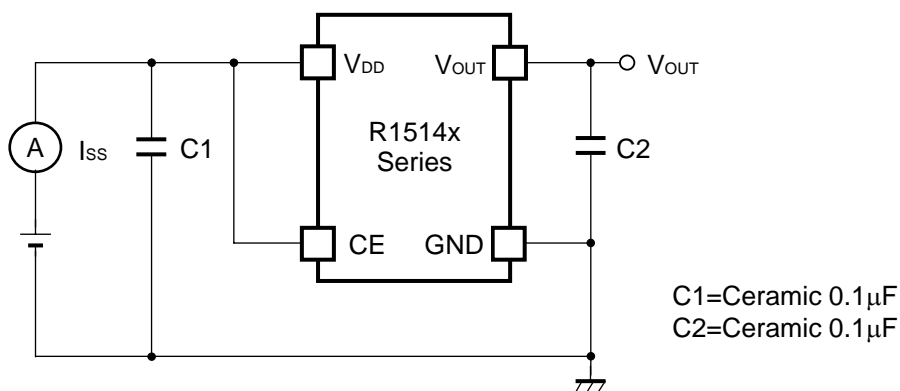

Test Circuit for Supply Current

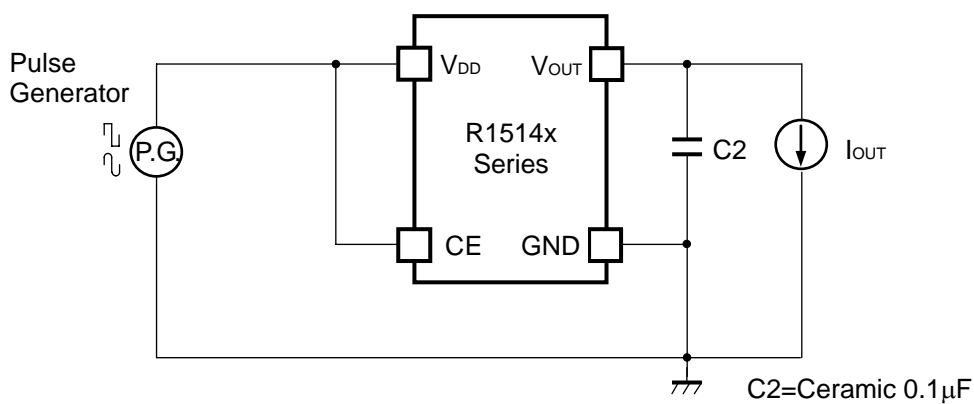

Test Circuit for Line Transient Response

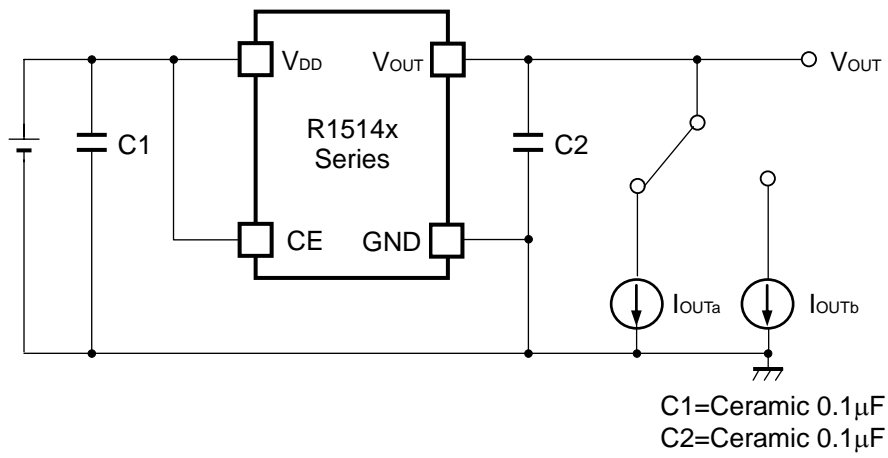

Test Circuit for Load Transient Response

TYPICAL CHARACTERISTICS

1) Output Voltage vs. Output Current ($T_{opt}=25^{\circ}\text{C}$)

R1514x020B

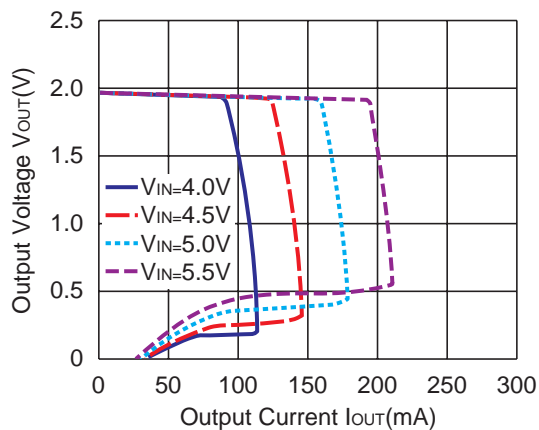

R1514x030B

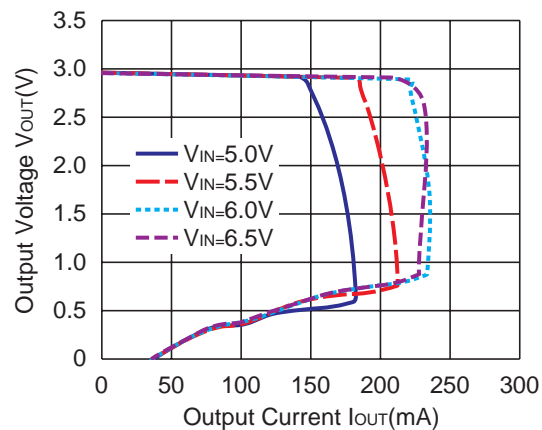

R1514x050B

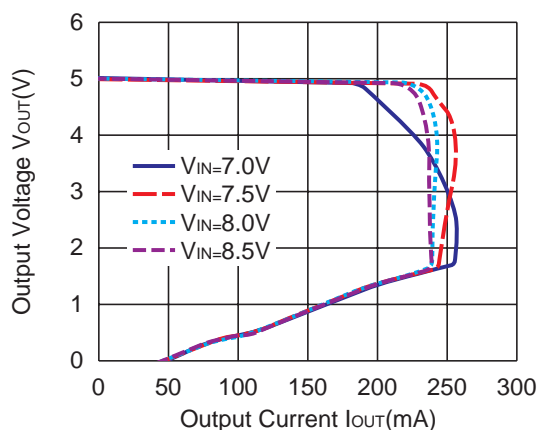

R1514x090B

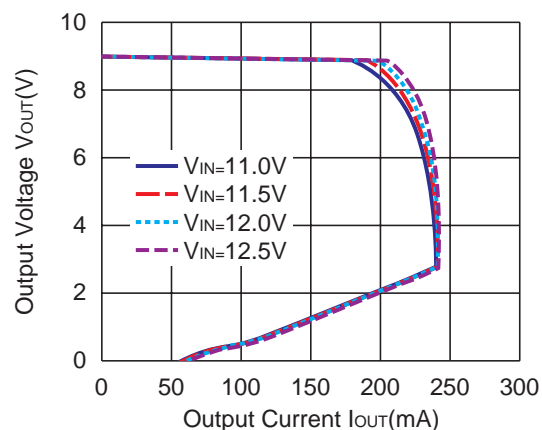

2) Output Voltage vs. Input Voltage ($T_{opt}=25^{\circ}\text{C}$)

R1514x020B

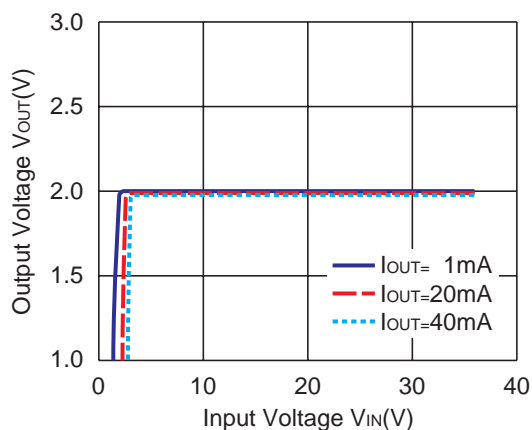

R1514x030B

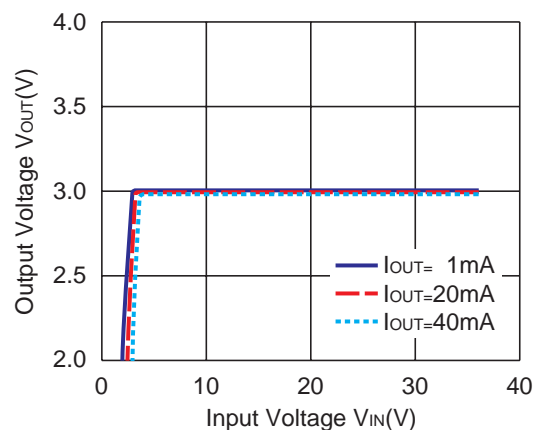

R1514x050B

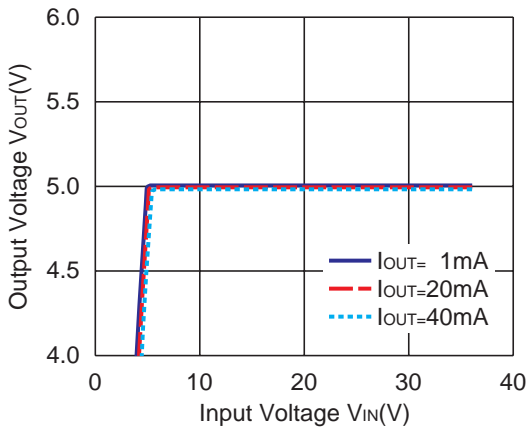

R1514x090B

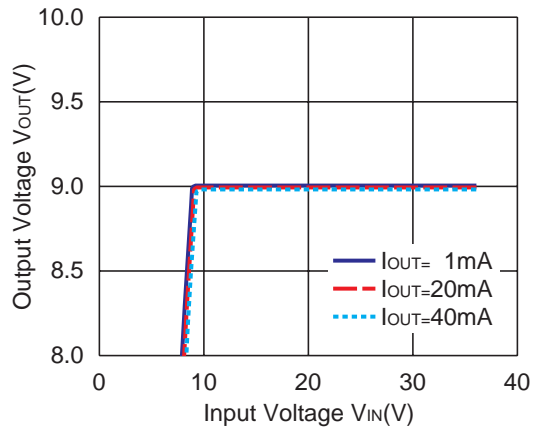

3) Dropout Voltage vs. Output Current

R1514x020B

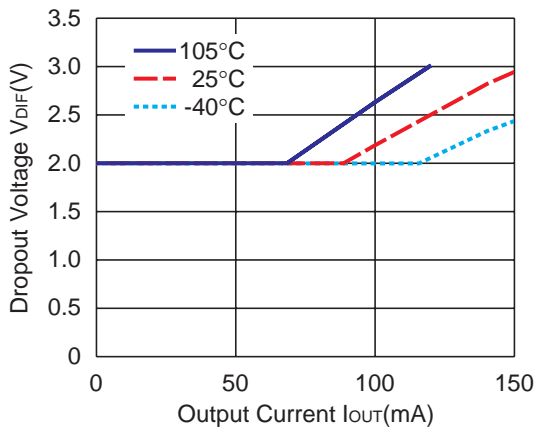

R1514x030B

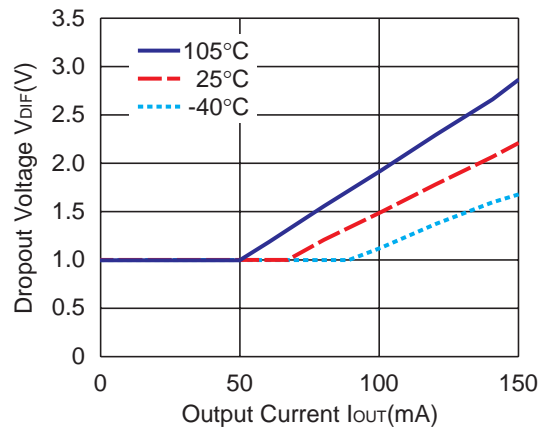

R1514x050B

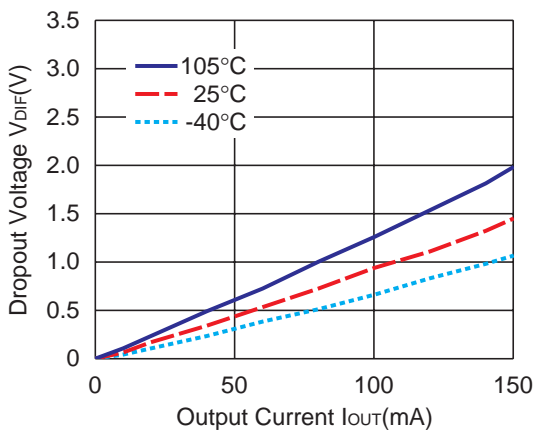

R1514x090B

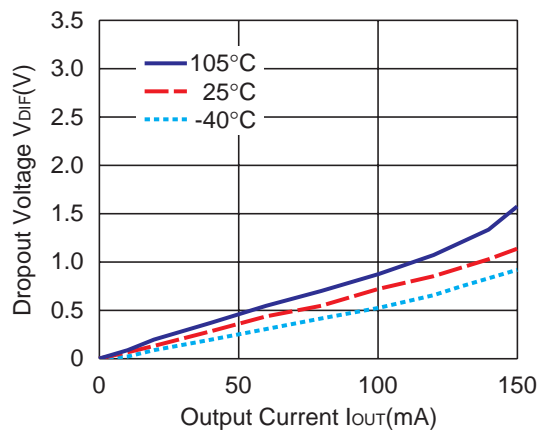

4) Output Voltage vs. Temperature

R1514x020B

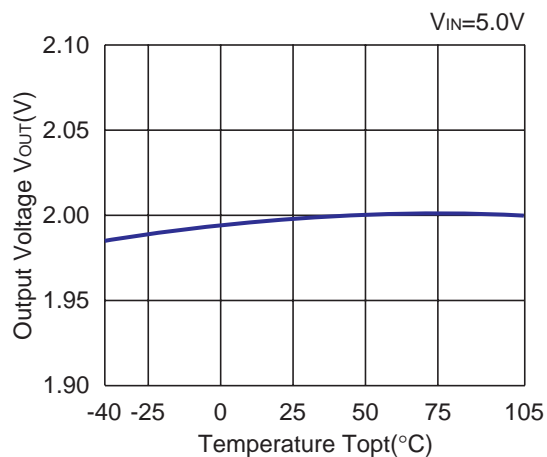

R1514x030B

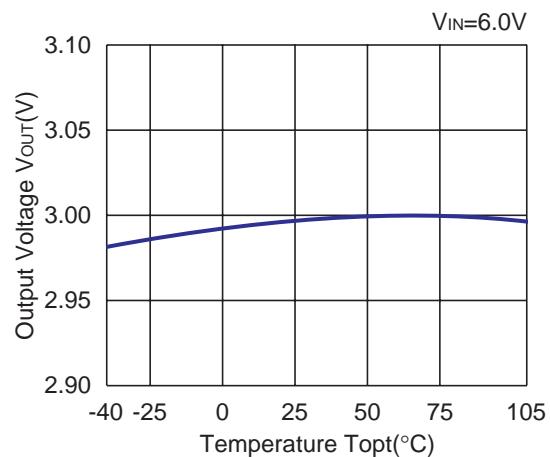

R1514x050B

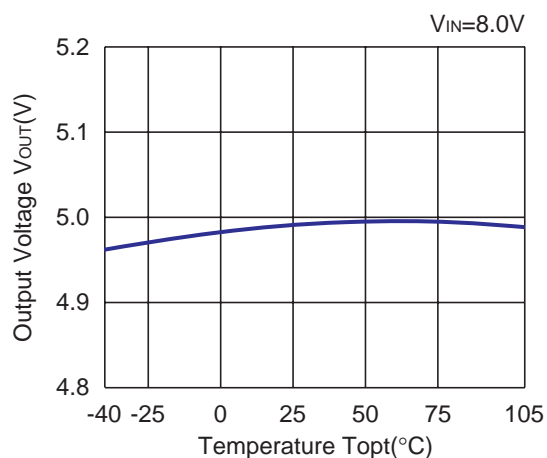

R1514x090B

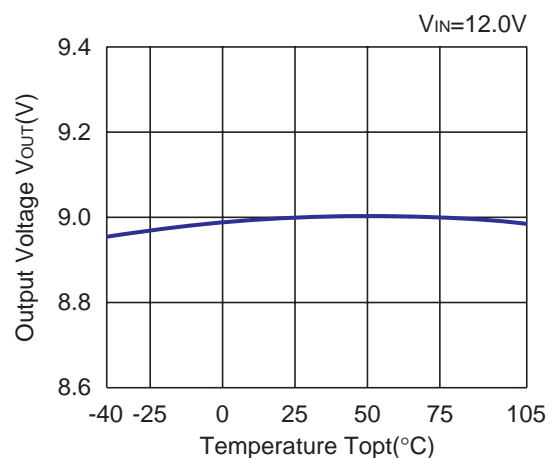
5) Supply Current vs. Input Voltage ($T_{opt}=25^{\circ}C$)

R1514x020B

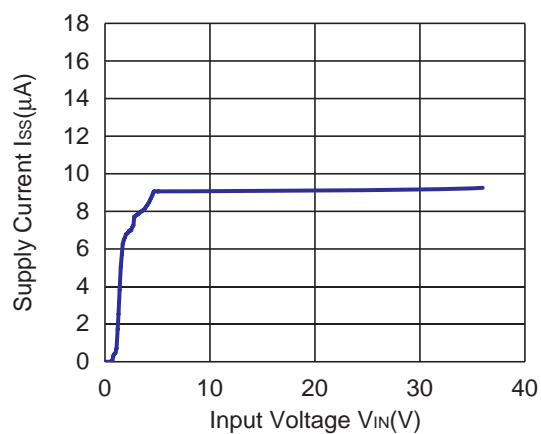

R1514x030B

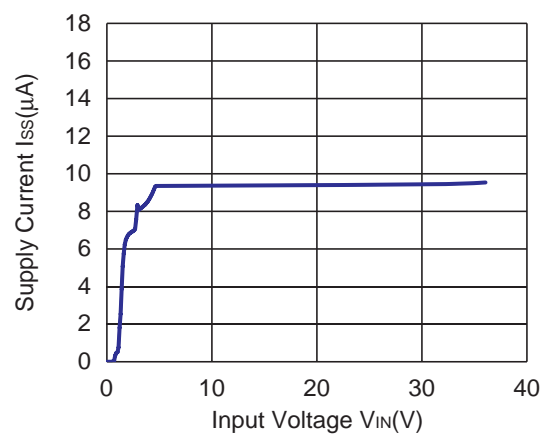

R1514x050B

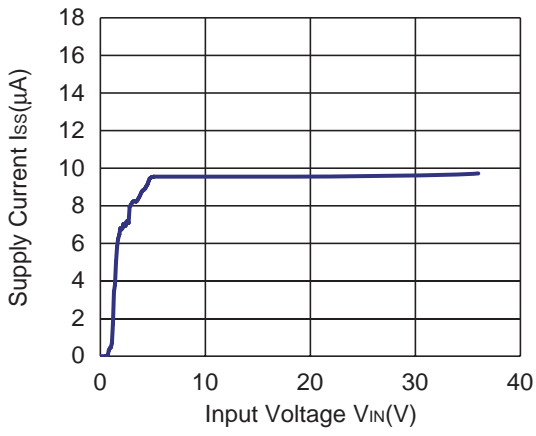

R1514x090B

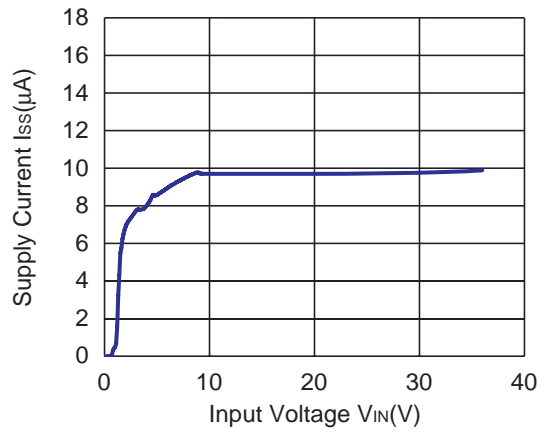

6) Supply Current vs. Temperature

R1514x020B

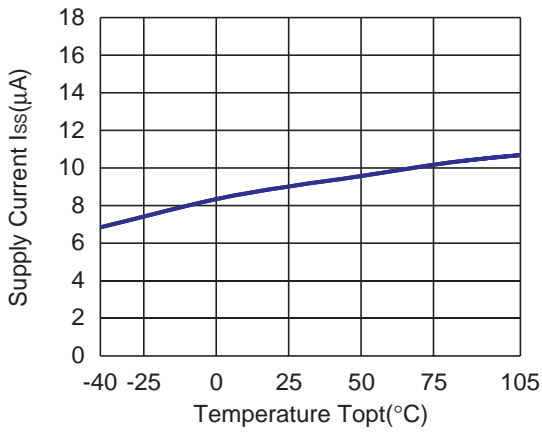

R1514x030B

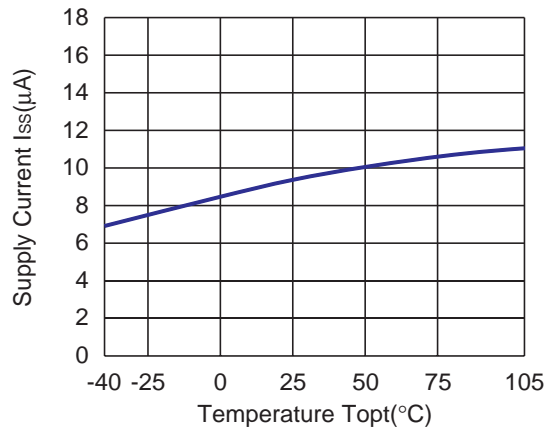

R1514x050B

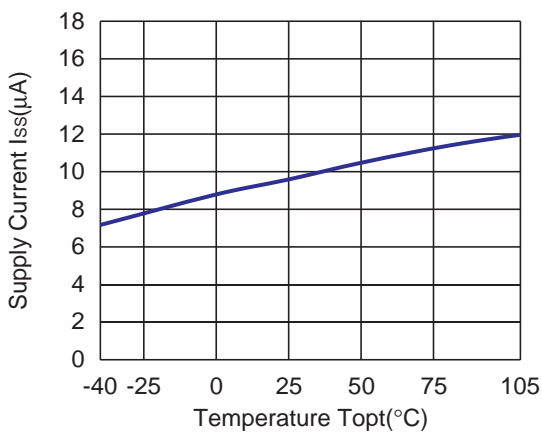

R1514x090B

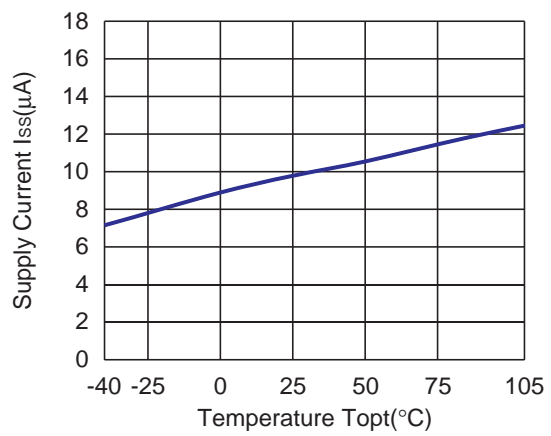

7) Input Transient Response ($I_{OUT}=1mA$, $t_r=t_f=50\mu s$, $C_2=Ceramic\ 0.1\mu F$, $T_{opt}=25^\circ C$)

R1514x020B

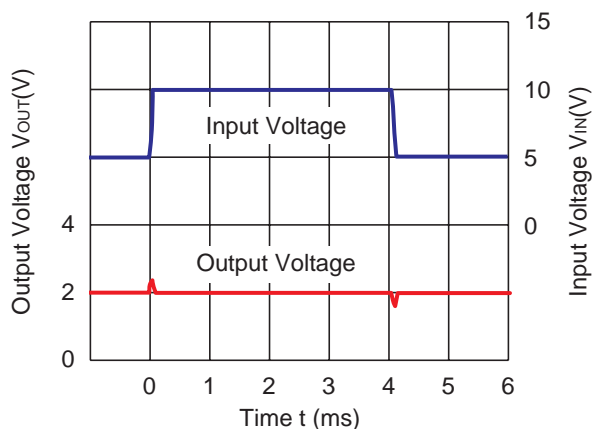

R1514x030B

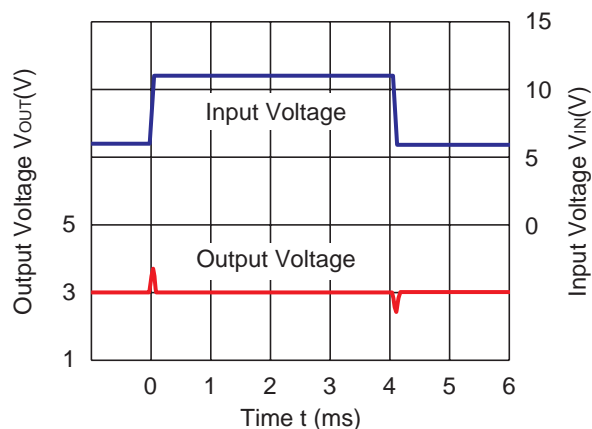

R1514x050B

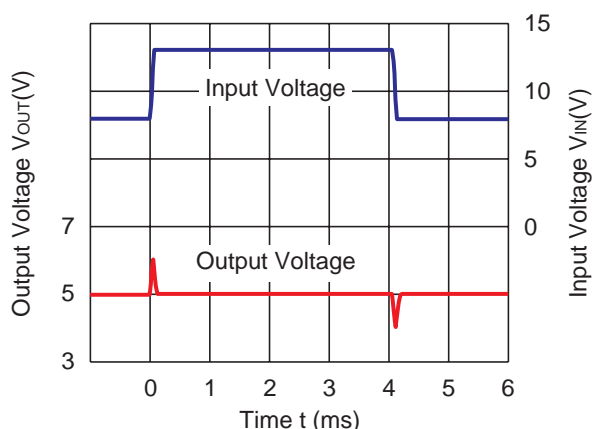

R1514x090B

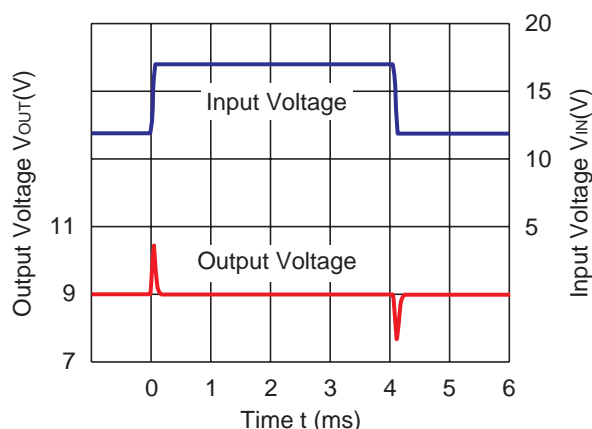

8) Load Transient Response ($C_2=Ceramic\ 0.1\mu F$, $T_{opt}=25^\circ C$)

R1514x020B

$V_{IN}=5.0V$
 $t_r=t_f=50\mu s$

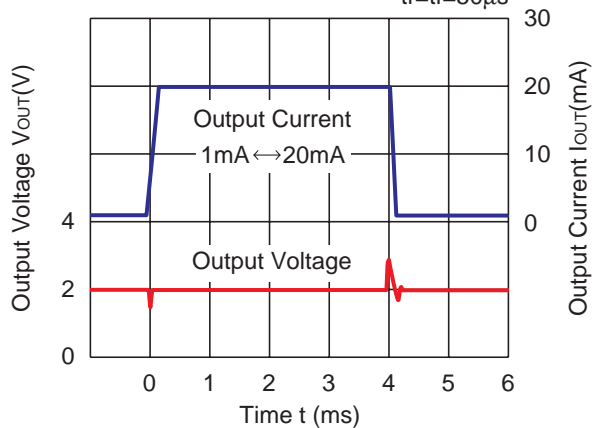

R1514x030B

$V_{IN}=6.0V$
 $t_r=t_f=50\mu s$

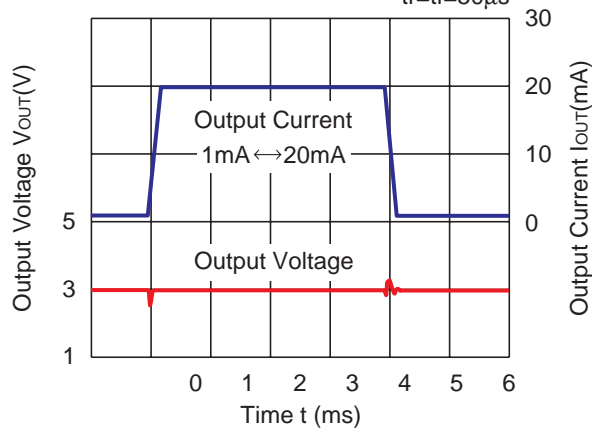

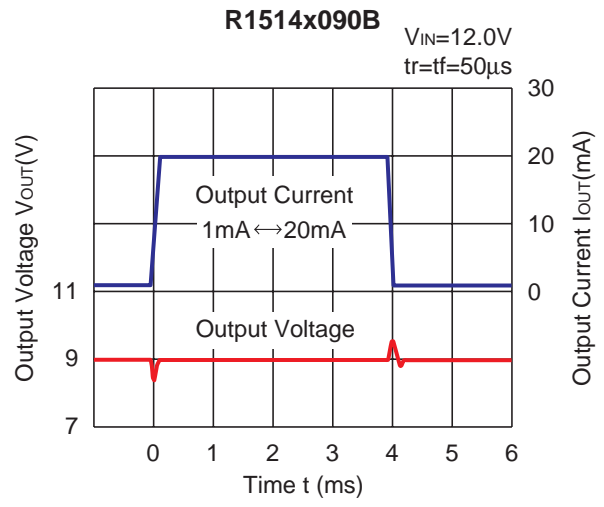
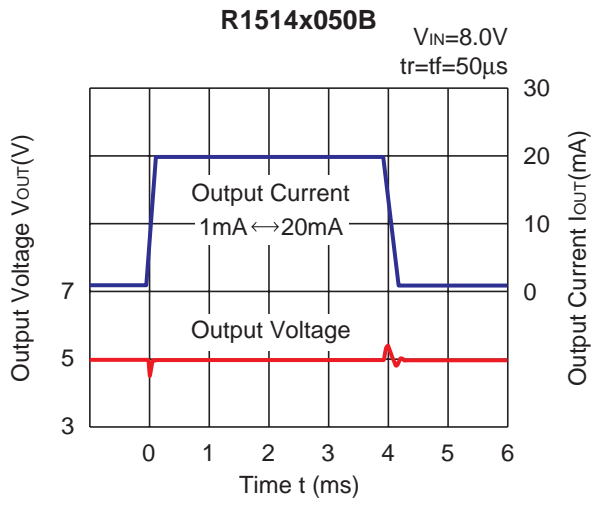



1. The products and the product specifications described in this document are subject to change or discontinuation of production without notice for reasons such as improvement. Therefore, before deciding to use the products, please refer to Ricoh sales representatives for the latest information thereon.
2. The materials in this document may not be copied or otherwise reproduced in whole or in part without prior written consent of Ricoh.
3. Please be sure to take any necessary formalities under relevant laws or regulations before exporting or otherwise taking out of your country the products or the technical information described herein.
4. The technical information described in this document shows typical characteristics of and example application circuits for the products. The release of such information is not to be construed as a warranty of or a grant of license under Ricoh's or any third party's intellectual property rights or any other rights.
5. The products listed in this document are intended and designed for use as general electronic components in standard applications (office equipment, telecommunication equipment, measuring instruments, consumer electronic products, amusement equipment etc.). Those customers intending to use a product in an application requiring extreme quality and reliability, for example, in a highly specific application where the failure or misoperation of the product could result in human injury or death (aircraft, spacevehicle, nuclear reactor control system, traffic control system, automotive and transportation equipment, combustion equipment, safety devices, life support system etc.) should first contact us.
6. We are making our continuous effort to improve the quality and reliability of our products, but semiconductor products are likely to fail with certain probability. In order to prevent any injury to persons or damages to property resulting from such failure, customers should be careful enough to incorporate safety measures in their design, such as redundancy feature, fire containment feature and fail-safe feature. We do not assume any liability or responsibility for any loss or damage arising from misuse or inappropriate use of the products.
7. Anti-radiation design is not implemented in the products described in this document.
8. The X-ray exposure can influence functions and characteristics of the products. Confirm the product functions and characteristics in the evaluation stage.
9. WLCSP products should be used in light shielded environments. The light exposure can influence functions and characteristics of the products under operation or storage.
10. There can be variation in the marking when different AOI (Automated Optical Inspection) equipment is used. In the case of recognizing the marking characteristic with AOI, please contact Ricoh sales or our distributor before attempting to use AOI.
11. Please contact Ricoh sales representatives should you have any questions or comments concerning the products or the technical information.



Ricoh is committed to reducing the environmental loading materials in electrical devices with a view to contributing to the protection of human health and the environment.

Ricoh has been providing RoHS compliant products since April 1, 2006 and Halogen-free products since April 1, 2012.

RICOH RICOH ELECTRONIC DEVICES CO., LTD.

<https://www.e-devices.ricoh.co.jp/en/>

Sales & Support Offices

Ricoh Electronic Devices Co., Ltd.

Shin-Yokohama Office (International Sales)

2-3, Shin-Yokohama 3-chome, Kohoku-ku, Yokohama-shi, Kanagawa, 222-8530, Japan
Phone: +81-50-3814-7687 Fax: +81-45-474-0074

Ricoh Americas Holdings, Inc.

675 Campbell Technology Parkway, Suite 200 Campbell, CA 95008, U.S.A.
Phone: +1-408-610-3105

Ricoh Europe (Netherlands) B.V.

Semiconductor Support Centre

Prof. W.H. Keesomlaan 1, 1183 DJ Amstelveen, The Netherlands
Phone: +31-20-5474-309

Ricoh International B.V. - German Branch

Semiconductor Sales and Support Centre

Oberrather Strasse 6, 40472 Düsseldorf, Germany
Phone: +49-211-6546-0

Ricoh Electronic Devices Korea Co., Ltd.

3F, Haesung Bldg, 504, Teheran-ro, Gangnam-gu, Seoul, 135-725, Korea
Phone: +82-2-2135-5700 Fax: +82-2-2051-5713

Ricoh Electronic Devices Shanghai Co., Ltd.

Room 403, No.2 Building, No.690 Bibo Road, Pu Dong New District, Shanghai 201203,
People's Republic of China
Phone: +86-21-5027-3200 Fax: +86-21-5027-3299

Ricoh Electronic Devices Shanghai Co., Ltd.

Shenzhen Branch

1205, Block D (Jinlong Building), Kingkey 100, Hongbao Road, Luohu District,
Shenzhen, China
Phone: +86-755-8348-7600 Ext 225

Ricoh Electronic Devices Co., Ltd.

Taipei office

Room 109, 10F-1, No.51, Hengyang Rd., Taipei City, Taiwan (R.O.C.)
Phone: +886-2-2313-1621/1622 Fax: +886-2-2313-1623