

MAXIM

+3.3V-Powered, EIA/TIA-562 Dual Transceiver with Receivers Active in Shutdown

General Description

The MAX563 is a +3.3V-powered EIA/TIA-562 transceiver with two transmitters and two receivers. Because it implements the EIA/TIA-562 standard, the MAX563 communicates with RS-232 transceivers, yet consumes far less power; this makes it ideal for battery-powered, hand-held computers. And, the MAX563 guarantees a 116kbps data rate while maintaining $\pm 3.7V$ EIA/TIA-562 signal levels, which makes it compatible with LapLink™ software.

An on-board charge pump converts the +3.3V supply to the $\pm 6.6V$ needed to produce the EIA/TIA-562 output voltage levels. Four 0.1 μF charge-pump capacitors and a bypass capacitor of similar size are the only external components required.

When the MAX563's charge pumps and transmitters are shut down to save power, the receivers remain active to continuously monitor signals from external devices (for example, ring indicator from modems). The two receivers' outputs can be enabled and disabled independently of the shutdown function to allow two ports—generally of different types—to be wire-OR connected at the UART.

Applications

Handterminals
Battery-Powered Equipment
Bar-Code Readers
Notebook and Palmtop Computers

Typical Operating Circuit

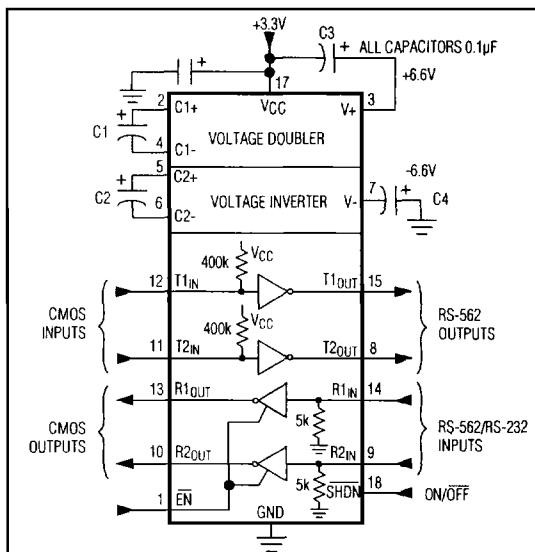

™ LapLink is a registered trademark of Traveling Software, Inc.

Features

- ◆ Guaranteed Interoperability with RS-232
- ◆ Operates from a Single +3.0V to +3.6V Supply
- ◆ 2 Drivers, 2 Receivers
- ◆ Receivers Active in Shutdown Mode
- ◆ Low-Power Shutdown: 10 μA Max
- ◆ Small Package—18-Pin Wide SO
- ◆ Three-State TTL/CMOS Receiver Outputs
- ◆ 116kbps Guaranteed Data Rate

Ordering Information

PART	TEMP. RANGE	PIN-PACKAGE
MAX563CPN	0°C to +70°C	18 Plastic DIP
MAX563CWN	0°C to +70°C	18 Wide SO
MAX563C/D	0°C to +70°C	Dice *

* Dice are specified at $T_A = +25^\circ C$.

Pin Configuration

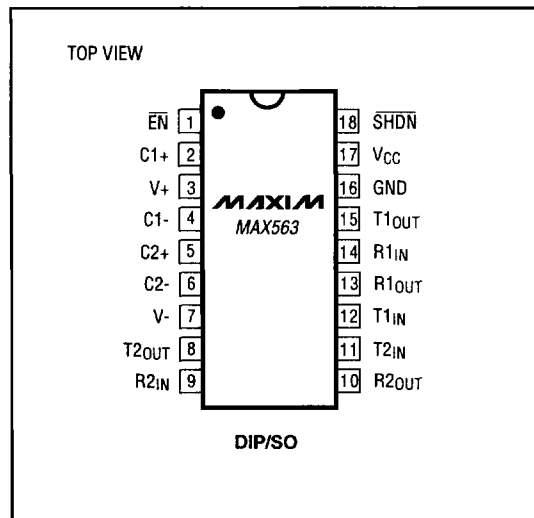

MAX563

2

MAXIM

Maxim Integrated Products 2-183

Call toll free 1-800-998-8800 for free samples or literature.

+3.3V-Powered, EIA/TIA-562 Dual Transceiver with Receivers Active in Shutdown

ABSOLUTE MAXIMUM RATINGS

Power Supply Ranges		Continuous Power Dissipation (T _A = +70°C)	
Supply Voltage (V _{CC})	-0.3V to +6V	Plastic DIP	889mW
Input Voltages		Wide SO	762mW
T _{IN}	-0.3V to (V _{CC} - 0.3V)	Operating Temperature Range	0°C to +70°C
R _{IN}	±25V	Storage Temperature Range	-65°C to +160°C
T _{OUT} (Note 1)	±15V	Lead Temperature (soldering, 10sec)	+300°C
Output Voltages			
T _{OUT}	±15V		
R _{OUT}	-0.3V to (V _{CC} + 0.3V)		
Driver/Receiver Output Short Circuit to GND	Continuous		

Note 1: Input voltage measured with T_{OUT} in high-impedance state. SHDN or V_{CC} = 0V.

Stresses beyond those listed under "Absolute Maximum Ratings" may cause permanent damage to the device. These are stress ratings only, and functional operation of the device at these or any other conditions beyond those indicated in the operational sections of the specifications is not implied. Exposure to absolute maximum rating conditions for extended periods may affect device reliability.

ELECTRICAL CHARACTERISTICS

(V_{CC} = 3.0V to 3.6V, C1-C4 = 0.1μF, T_A = T_{MIN} to T_{MAX}, unless otherwise noted.)

PARAMETER	SYMBOL	CONDITIONS	MIN	TYP	MAX	UNITS
RS-562 TRANSMITTERS						
Output Voltage Swing		All transmitter outputs loaded with 3kΩ to GND	±3.7	±4.5		V
Data Rate		R _L = 3kΩ, C _L = 1000pF, T _A = +25°C		200	116	kbps
Input Logic Threshold Low	V _{IL}				0.6	V
Input Logic Threshold High	V _{IH}		2.4			V
Logic Pull-Up/Input Current		SHDN = V _{CC}		2	20	μA
		SHDN = 0V		±0.01	±1	
Output Leakage Current		V _{CC} = 3.6V, SHDN = 0V, V _{OUT} = ±15V		±0.01	±10	μA
		V _{CC} = SHDN = 0V, V _{OUT} = ±15V		±0.01	±10	
Transmitter Output Resistance		V _{CC} = V ₊ = V ₋ = 0V, V _{OUT} = ±2V	300	10M		Ω
Output Short-Circuit Current		V _{OUT} = 0V		±15	±60	mA
RS-232/RS-562 RECEIVERS						
Input Voltage Operating Range					±25	V
Input Threshold Low	V _{IL}	V _{CC} = 3.3V			0.4	V
Input Threshold High	V _{IH}	V _{CC} = 3.3V	2.4			V
Input Hysteresis		SHDN = V _{CC} = 3.3V (no hysteresis when SHDN = 0V)	0.1	0.5	1.0	V
Input Resistance	R _{IN}		3	5	7	kΩ
Output Voltage Low	V _{OL}	I _{OUT} = 3.2mA		0.2	0.4	V
Output Voltage High	V _{OH}	I _{OUT} = -0.5mA	V _{CC} -0.6	V _{CC} -0.2		V
Output Leakage Current		ĒN = V _{CC} , 0V ≤ V _{OUT} ≤ V _{CC}		±0.05	±10	μA
ĒN Input Threshold Low	V _{IL}				0.6	V
ĒN Input Threshold High	V _{IH}		2.4			V

+3.3V-Powered, EIA/TIA-562 Dual Transceiver with Receivers Active in Shutdown

MAX563

ELECTRICAL CHARACTERISTICS (continued)

(V_{CC} = 3.0V to 3.6V, C₁-C₄ = 0.1μF, T_A = T_{MIN} to T_{MAX}, unless otherwise noted.)

PARAMETER	SYMBOL	CONDITIONS	MIN	TYP	MAX	UNITS
POWER SUPPLY						
Operating Supply Voltage	V _{CC}		3.0		3.6	V
V _{CC} Supply Current	I _{CC}	No load		3	8	mA
		R _L = 3kΩ on both outputs, inputs static		8		
Shutdown Supply Current	I _{CC}	Figure 1	T _A = +25°C	0.1	10	μA
			T _A = T _{MIN} to T _{MAX}	2	50	
SHDN Input Leakage Current			0.1		±1	μA
SHDN Threshold Low	V _{IL}				0.6	V
SHDN Threshold High	V _{IH}		2.4			V
AC CHARACTERISTICS						
Transition Slew Rate		C _L = 50pF to 2500pF, R _L = 3kΩ to 7kΩ, V _{CC} = 3.3V, T _A = +25°C, measured from +3V to -3V or -3V to +3V (Note 2)	4	6	30	V/μs
Transmitter Propagation Delay	t _{PHLT}	Figure 2		1.3	3.5	μs
	t _{PLHT}			1.5	3.5	
Receiver Propagation Delay (Normal Operation)	t _{PHLR}	Figure 3		0.5	1.0	μs
	t _{PLHR}			0.6	1.0	
Receiver Propagation Delay (Shutdown)	t _{PHLS}	Figure 3		0.5	10.0	μs
	t _{PLHS}			2.5	10.0	
Receiver-Output Enable Time	t _{ER}	Figure 4		125	500	ns
Receiver-Output Disable Time	t _{DR}	Figure 4		160	500	ns
Transmitter-Output Enable Time	t _{ET}	Includes charge pump start-up		300		μs
Transmitter-Output Disable Time	t _{DT}	Figure 5		600		ns
Transmitter Propagation Delay Skew	t _{PHLT} - t _{PLHT}			300		ns
Receiver Propagation Delay Skew (Normal Operation)	t _{PHLR} - t _{PLHR}			100		ns

2

Note 2: Minimum slew rate is specified with C_L = 1000pF for data rates above 20kbps, corresponding with EIA/TIA-562.

+3.3V-Powered, EIA/TIA-562 Dual Transceiver with Receivers Active in Shutdown

Pin Description

PIN	NAME	FUNCTION
1	EN	Receiver enable. Connect EN to GND to enable receivers, and take EN high to disable receivers.
2	C1+	Positive terminal of positive charge-pump capacitor.
3	V+	+2V _{CC} voltage generated by the positive charge pump. The voltage on V+ collapses to V _{CC} when SHDN is low.
4	C1-	Negative terminal of positive charge-pump capacitor.
5	C2+	Positive terminal of inverting charge-pump capacitor.
6	C2-	Negative terminal of inverting charge-pump capacitor.
7	V-	-2V _{CC} voltage generated by the inverting charge pump. The voltage on V- collapses to GND when SHDN is low.
8, 15	T2OUT, T1OUT	EIA/TIA-562 voltage-level transmitter outputs. These outputs are disabled (Hi-Z) when SHDN is low.
9, 14	R2IN, R1IN	EIA/TIA-562 and EIA/TIA-232 voltage-level receiver inputs.
10, 13	R2OUT, R1OUT	CMOS receiver outputs. These outputs are active regardless of the state of SHDN. They are enabled when EN is low, and disabled (Hi-Z) when EN is high.
11, 12	T2IN, T1IN	CMOS driver inputs.
16	GND	Ground.
17	VCC	+3.0V to +3.6V supply voltage.
18	SHDN	Shutdown control. Connect to GND to shut down the charge pumps and the transmitters. Take high to turn on the charge pumps and to enable the transmitters.

Detailed Description

The MAX563 consists of three sections: charge-pump voltage converters, transmitters (drivers), and receivers. Both the transmitters and the receivers are inverting.

+3V to ±6V, Dual Charge-Pump Voltage Converter

Two charge pumps either invert or double the incoming V_{CC} to generate the voltages required by the transmitters. The first charge pump uses capacitor C1 to double V_{CC}; the resulting voltage is stored on the V+ reservoir capacitor. The second charge pump uses capacitor C2 to invert V+; this negative voltage is stored on the V- capacitor.

When SHDN is low, the charge pumps are turned off, V+ is pulled down to V_{CC} by a 1kΩ resistor, and V- rises to GND.

It is possible to draw some power from the V+ and V- pins for external use. However, doing so diminishes the charge-pump output voltages and reduces noise margins, so it is not recommended.

EIA/TIA-562 Transmitters

The MAX563's drivers are inverting level translators that convert +3V logic inputs to EIA/TIA-562 voltage levels. With a V_{CC} supply of only 3.0V, the driver outputs deliver the EIA/TIA-562 ±3.7V minimum specification under worst-case conditions—when both transmitters are loaded with 3kΩ receivers (either EIA/TIA-232 or EIA/TIA-562).

The transmitters are fast: the guaranteed data rate with standard loads is 116kbps, which is the highest rate commonly used by PC-to-PC communication software, such as LapLink. The highest practical data rate may be reduced if the other communicating device (RS-562 or RS-232) is not as fast, or if the cables present an excessive capacitive load (>1000pF). Each transmitter is designed to drive a single receiver; transmitters can be paralleled to drive multiple receivers.

When SHDN is low, the driver outputs are turned off. Their output leakage currents are less than 10μA when pulled to GND or when driven to ±15V. This enables two transmitters to be connected to the same line, provided that one of them is always disabled by taking SHDN low.

+3.3V-Powered, EIA/TIA-562 Dual Transceiver with Receivers Active in Shutdown

MAX563

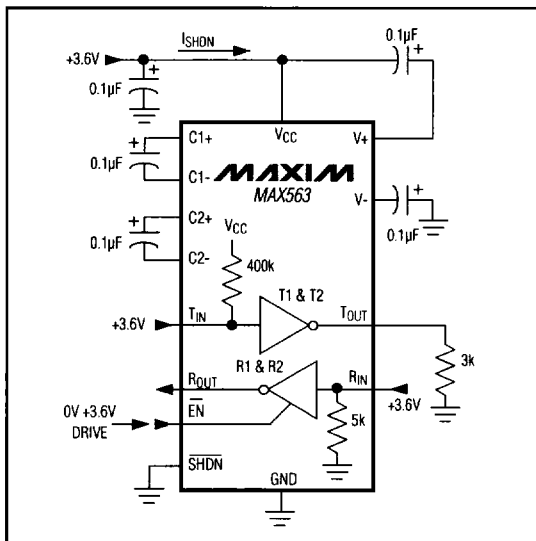

Figure 1. Shutdown Current Test Circuit

The inputs of unused drivers may be left unconnected because they have internal 400kΩ pull-ups to VCC. Unused inputs may also be connected to GND or VCC, but VCC provides lower power consumption because of the internal pull-ups.

EIA/TIA-562 and EIA/TIA-232 Receivers

The MAX563's receivers convert $\pm 3.7V$ to $\pm 13.2V$ EIA/TIA-562 signal levels into +3V logic levels; they are rated to receive signals up to $\pm 25V$ to accommodate EIA/TIA-232 signals as well. Both receivers invert. Their inputs are each equipped with an internal 5kΩ (nominal) terminating resistor connected to ground, and the input logic thresholds are 0.4V and 2.4V. The positive logic-low threshold (V_{IL}) ensures the receiver outputs remain high whenever their inputs are left open.

The receivers are active when \overline{EN} is low, and have high-impedance outputs when \overline{EN} is high.

When \overline{SHDN} is high, the receivers have hysteresis. This produces clean output transitions, even with slow-moving input signals that exhibit moderate amounts of noise and ringing. When shut down, the receivers have no hysteresis, and the propagation delay increases.

Shutdown and Enable Control

The \overline{SHDN} and \overline{EN} controls are independent. Both receivers are always active when \overline{EN} is low. With \overline{EN} low and \overline{SHDN} high, the receivers operate at full speed

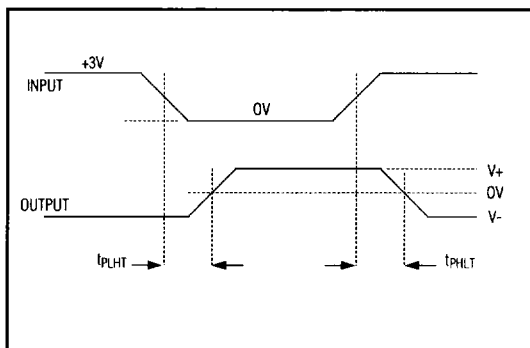

Figure 2. Transmitter Propagation Delay Timing

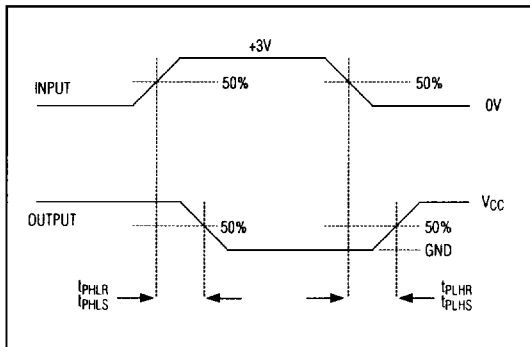

Figure 3. Receiver Propagation Delay Timing

and have hysteresis. When active in shutdown mode ($\overline{EN} = \overline{SHDN} = \text{low}$), the receivers operate at reduced power and speed, and without hysteresis.

The charge pumps and transmitters operate only when \overline{SHDN} is high; they are unaffected by \overline{EN} . When shutdown ($\overline{SHDN} = \text{low}$) or unpowered ($V_{CC} = 0V$), the transmitter outputs are high impedance if they are backdriven with voltages not exceeding $\pm 15V$. The pull-up resistors at the driver inputs are disconnected in shutdown mode to save power. During shutdown, $V+$ is pulled down to V_{CC} , and $V-$ rises to GND.

2

+3.3V-Powered, EIA/TIA-562 Dual Transceiver with Receivers Active in Shutdown

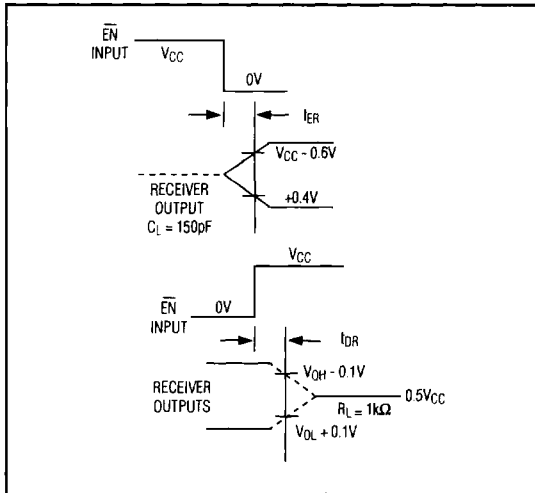

Figure 4. Receiver Output Enable and Disable Timing

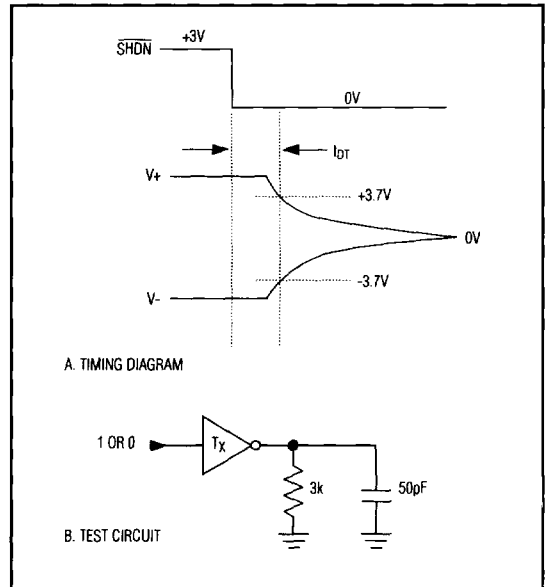

Figure 5. Transmitter Output Disable Timing

Applications Information

Charge-Pump Capacitor Selection

Normally, 0.1 μ F capacitors can be used for all locations. To reduce output ripple, increase the values of the V+ and V- capacitors. If your capacitors have a very wide tolerance, consider using a nominal value a little larger than 0.1 μ F to ensure that the actual capacitance does not fall below about 80nF. For circuits designed to operate over a wide range of temperatures, consider using slightly larger capacitors to compensate for any loss of capacitance at temperature extremes. No advantage is gained by using values larger than 10 μ F.

Power-Supply Decoupling

Use a capacitor with the same value as the charge-pump capacitors.

+3.3V-Powered, EIA/TIA-562 Dual Transceiver with Receivers Active in Shutdown

MAX563

Table 1. Summary of EIA/TIA-232E/V.28 and EIA/TIA-562 Specifications

PARAMETER	CONDITION	EIA/TIA-232E/V.28 SPECIFICATION	EIA/TIA-562 SPECIFICATION
Driver Output Voltage 0 Level 1 Level	3k Ω to 7k Ω load	5.0V to 15.0V	3.7V to 13.2V
		-5.0V to -15.0V	-3.7V to -13.2V
Maximum Output Level	No load	$\pm 25V$	$\pm 13.2V$
Signal Rate (3k $\Omega \leq R_L \leq 7k\Omega$)	C _L = 2500pF	Up to 20kbps	Up to 20kbps
	C _L = 1000pF	Not defined	Up to 64kbps
Receiver Input Thresholds 0 Level 1 Level		3.0V to 15.0V	3.0V to 15.0V
		-3.0V to -15.0V	-3.0V to -15.0V
Maximum Input Level		$\pm 25V$	$\pm 25V$
Maximum Instantaneous Slew Rate		30V/ μs	30V/ μs
Maximum Driver Output Short-Circuit Current		100mA	60mA
Transition Rate on Driver Output		V.28 1ms or 3% of the period	4V/ μs
		RS-232 4% of the period	
Driver Output Resistance with Power Off	-2V < V _{OUT} < 2V	300 Ω	300 Ω

2

Table 2. DB9/DB25 Cable Connections Commonly Used for EIA/TIA-232E, EIA/TIA-562 and V.24 Asynchronous Interfaces

DB9 PIN	DB25 PIN	NAME	SYMBOL	FUNCTION
1	8	Received Line Signal Detector (sometimes called Data Carrier Detect)	DCD	Handshake from DCE
2	3	Receiver Data	RxD	Data from DCE
3	2	Transmit Data	TxD	Data from DTE
4	20	Data Terminal Ready	DTR	Handshake from DTE
5	7	Signal Ground	GND	Reference point for signals
6	6	Data Set Ready	DSR	Handshake from DCE
7	4	Request to Send	RTS	Handshake from DTE
8	5	Clear to Send	CTS	Handshake from DCE
9	22	Ring Indicator	RI	Handshake from DCE

+3.3V-Powered, EIA/TIA-562 Dual Transceiver with Receivers Active in Shutdown

MAX563

Chip Topography

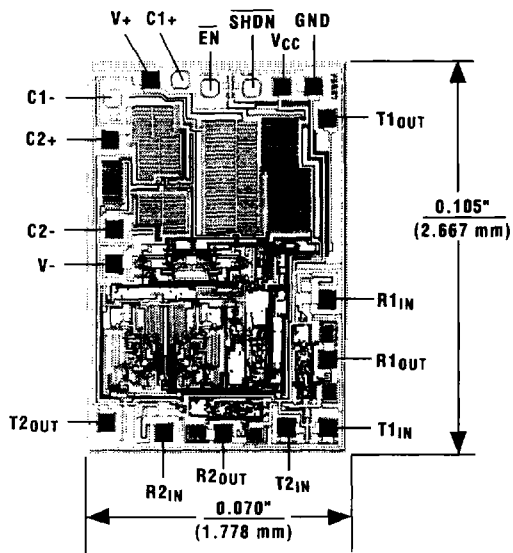

TRANSISTOR COUNT: 189;
SUBSTRATE CONNECTED TO V+.