

For Immediate Assistance, Contact Your Local Salesperson

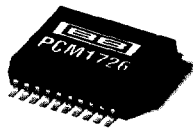

PCM1726

www.burr-brown.com/databook/PCM1726.html

SoundPlus™ Stereo Audio DIGITAL-TO-ANALOG CONVERTER 16 Bits, 96kHz Sampling

FEATURES

- **COMPLETE STEREO DAC:** Includes Digital Filter and Output Amp
- **DYNAMIC RANGE:** 96dB
- **MULTIPLE SAMPLING FREQUENCIES:** 16kHz to 96kHz
8X Oversampling at All Sampling Frequencies
- **SYSTEM CLOCK:** 256f_s/384f_s
- **NORMAL OR I²S DATA INPUT FORMATS**
- **SOFT MUTE**

DESCRIPTION

The PCM1726 is a complete low cost stereo audio digital-to-analog converter (DAC), operating off of a 256f_s or 384f_s system clock. The DAC contains a 3rd-order $\Delta\Sigma$ modulator, a digital interpolation filter, and an analog output amplifier. The PCM1726 accepts 16-bit input data in either normal or I²S formats.

The digital filter performs an 8X interpolation function and includes soft mute. The PCM1726 can accept standard digital audio sampling frequencies as well as one-half and double sampling frequencies.

The PCM1726 is ideal for applications which combine compressed audio and video data such as DVD, DVD-ROM, set-top boxes and MPEG sound cards.

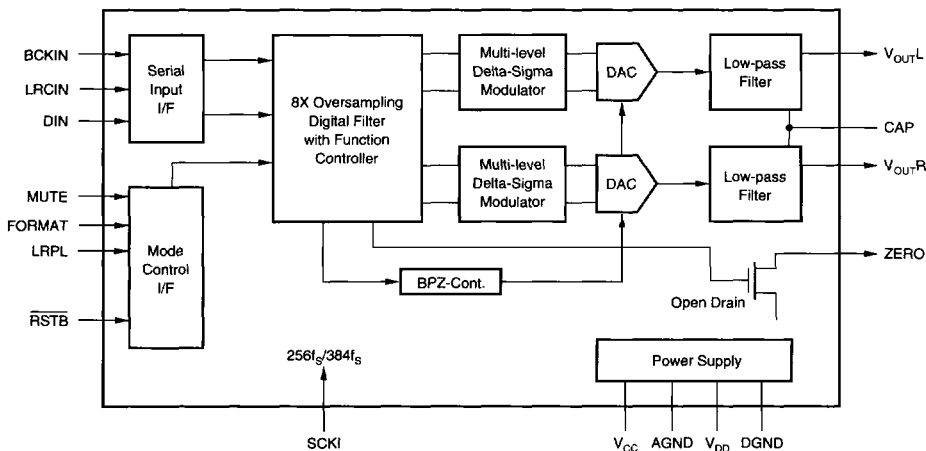

International Airport Industrial Park • Mailing Address: PO Box 11400, Tucson, AZ 85734 • Street Address: 6730 S. Tucson Blvd., Tucson, AZ 85706 • Tel: (520) 746-1111 • Twx: 910-952-1111
Internet: <http://www.burr-brown.com/> • FAXLine: (800) 548-6133 (US/Canada Only) • Cable: BBRCORP • Telex: 066-6491 • FAX: (520) 889-1510 • Immediate Product Info: (800) 548-6132

Or, Call Customer Service at 1-800-548-6132 (USA Only)

SPECIFICATIONS

All specifications at +25°C, +V_{CC} = +V_{DD} = +5V, f_S = 44.1kHz, and 16-bit input data, SYSCLK = 384f_S, unless otherwise noted.

PARAMETER	CONDITIONS	PCM1726			UNITS
		MIN	TYP	MAX	
RESOLUTION				16	Bits
DATA FORMAT			Standard/I ² S		
Audio Data Format			16		
Data Bit Length		16		96	kHz
Sampling Frequency (f _S)			256f _S /384f _S		
Internal System Clock Frequency					
DIGITAL INPUT/OUTPUT LOGIC LEVEL			TTL		
DYNAMIC PERFORMANCE⁽¹⁾					
THD+N at f _S (0dB)	f _S = 44.1kHz		-90	-80	dB
	f _S = 96kHz		-88		dB
THD+N at -60dB	f _S = 44.1kHz		-34		dB
	f _S = 96kHz		-31		dB
Dynamic Range	f _S = 44.1kHz	90	96		dB
	f _S = 96kHz		93		dB
Signal-to-Noise Ratio ⁽²⁾	f _S = 44.1kHz	92	100		dB
	f _S = 96kHz		97		dB
Channel Separation	f _S = 44.1kHz	90	97		dB
DC ACCURACY					
Gain Error			±1.0	±5.0	% of FSR
Gain Mismatch, Channel-to-Channel			±1.0	±5.0	% of FSR
Bipolar Zero Error	V _{OUT} = V _{CC} /2 at BPZ		±30		mV
ANALOG OUTPUT					
Output Voltage	Full Scale (0dB)		0.62 x V _{CC}		V _{p-p}
Center Voltage			V _{CC} /2		VDC
Load Impedance	AC Load	5			kΩ
DIGITAL FILTER PERFORMANCE					
Passband				0.445	f _S
Stopband		0.555			f _S
Passband Ripple				±0.17	dB
Stopband Attenuation		-35			dB
Delay Time			11.125/f _S		sec
INTERNAL ANALOG FILTER					
-3dB Bandwidth			100		kHz
Passband Response	f = 20kHz		-0.16		dB
POWER SUPPLY REQUIREMENTS					
Voltage Range	V _{DD} , V _{CC}	4.5	5	5.5	VDC
Supply Current: I _{CC} + I _{DD}	V _{CC} = V _{DD} = 5V, f _S = 44.1kHz		18	25	mA
	V _{CC} = V _{DD} = 5V, f _S = 96kHz		25	35	mA
TEMPERATURE RANGE					
Operation		-25		+85	°C
Storage		-55		+100	°C

NOTES: (1) Dynamic performance specs are tested with 20kHz low pass filter and THD+N specs are tested with 30kHz LPF, 400Hz HPF, Average-Mode. (2) SNR is tested with Infinite Zero Detection off.

PCM1726

DIGITAL AUDIO PRODUCTS—D/A



For Immediate Assistance, Contact Your Local Salesperson

PIN CONFIGURATION

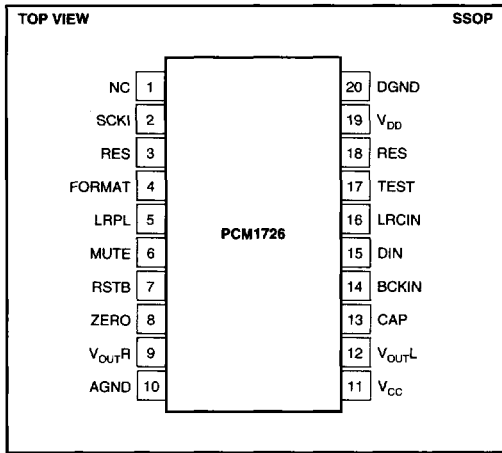

PACKAGE INFORMATION

PRODUCT	PACKAGE	PACKAGE DRAWING NUMBER ⁽¹⁾
PCM1726E	20-Pin SSOP	334-1

NOTE: (1) For detailed drawing and dimension table, please see end of data sheet, or Appendix C of Burr-Brown IC Data Book.

ABSOLUTE MAXIMUM RATINGS

Power Supply Voltage	+6.5V
+V _{CC} to +V _{DD} Difference	±0.1V
Input Logic Voltage	-0.3V to (V _{DD} + 0.3V)
Power Dissipation	300mW
Operating Temperature Range	-25°C to +85°C
Storage Temperature	-55°C to +125°C
Lead Temperature (soldering, 5s)	+260°C
Thermal Resistance, θ_{JA}	+70°C/W

PIN ASSIGNMENTS

PIN	NAME	TYPE	FUNCTION
1	NC	—	No Connection.
2	SCKI	IN	System Clock Input: 256f _s or 384f _s .
3	RES	—	Reserved for Factory Use. Do not connect.
4 ⁽¹⁾	FORMAT	IN	Input Data Format Control.
5 ⁽¹⁾	LRPL	IN	Left/Right Polarity Control.
6 ⁽¹⁾	MUTE	IN	Soft Mute Control.
7 ⁽¹⁾	RSTB	IN	Reset Input. When this pin is low, the digital filters and modulators are held in reset.
8	ZERO	OUT	Zero Data Flag. This pin is low when the data is continuously zero for more than 65,535 cycles of BCKIN.
9	V _{OUTR}	OUT	Right Channel Analog Output.
10	AGND	PWR	Analog Ground.
11	V _{CC}	PWR	Analog Power Supply (+5V).
12	V _{OUTL}	OUT	Left Channel Analog Output.
13	CAP	—	Common Pin for Analog Output Amplifiers.
14 ⁽¹⁾	BCKIN	IN	Bit Clock for Clocking in the Audio Data.
15 ⁽¹⁾	DIN	IN	Serial Audio Data Input.
16 ⁽¹⁾	LRCIN	IN	Left/Right Word Clock. Frequency is equal to f _S .
17	TEST	—	Must be Tied to Ground.
18	RES	—	Do Not Connect.
19	V _{DD}	PWR	Digital Power Supply (+5V). Recommended connection is to the analog power supply.
20	DGND	PWR	Digital Ground. Recommended connection is to the digital ground plane.

NOTE: (1) These pins include internal pull-up resistors.



ELECTROSTATIC DISCHARGE SENSITIVITY

This integrated circuit can be damaged by ESD. Burr-Brown recommends that all integrated circuits be handled with appropriate precautions. Failure to observe proper handling and installation procedures can cause damage.

ESD damage can range from subtle performance degradation to complete device failure. Precision integrated circuits may be more susceptible to damage because very small parametric changes could cause the device not to meet its published specifications.