

## High Efficiency Snubber Diode

### Features and Benefits

- High Peak Reverse Voltage,  $V_{RM}$ : 800 V
- Low Forward Voltage,  $V_F$ : 0.92 V (max) at  $I_F = 1.2$  A
- Peak Forward Surge Current,  $I_{FSM}$ : 110 A
- Average Forward Current,  $I_{F(AV)}$ : 1.2 A
- Flammability rating UL94V-0 (Equivalent)
- Pins Pb (lead) free

### Package: Axial



### Description

The SARS01 is an 800 V silicon diode designed especially for use in high-efficiency snubber circuits. This diode can sustain a high voltage with low loss, with low-noise rectification.

### Applications

- White goods appliances
- Audio-visual equipment
- Light fixtures
- Communication equipment
- Factory automation

### Product Structure

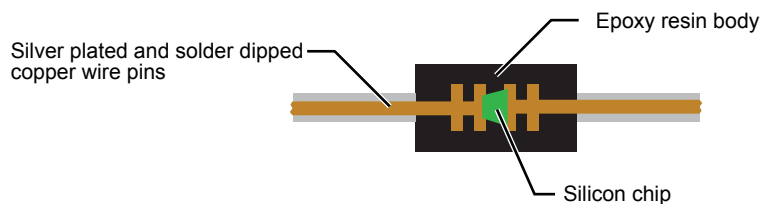

**Selection Guide**

Part Number	Packing*
SARS01V	5000 pieces per reel, 52 mm pitch axial taping
SARS01V1	2000 pieces per box, 52 mm pitch axial taping
SARS01V0	2000 pieces per box, 26 mm pitch axial taping
SARS01W	4000 pieces per box, radial taping

\*See the Packing Options page for details on the packing orientation.

**Absolute Maximum Ratings**

Characteristic	Symbol	Conditions	Rating	Unit
Peak Reverse Surge Voltage	$V_{RSM}$		800	V
Peak Reverse Voltage	$V_{RM}$		800	V
Average Forward Current	$I_{F(AV)}$	Refer to figure 1	1.2	A
Peak Forward Surge Current	$I_{FSM}$	10 ms, half sine wave, one shot	110	A
Junction Temperature	$T_j$		-40 to 150	°C
Storage Temperature	$T_{stg}$		-40 to 150	°C

Electrical Characteristics valid at  $T_A = 25^\circ\text{C}$ , unless otherwise specified

Characteristic	Symbol	Test Conditions	Value	Unit
Forward Voltage	$V_F$	$I_F = 1.2\text{ A}$	0.92 (max)	V
Reverse Current	$I_R$	$V_R = V_{RM}$	10 (max)	$\mu\text{A}$
Reverse Current (High Temperature)	$I_{R(H)}$	$V_R = V_{RM}, T_j = 100^\circ\text{C}$	50 (max)	$\mu\text{A}$
Reverse Recovery Time	$t_{rr}$	$I_F = I_{RP} = 10\text{ mA}$ , 90% recovery point; refer to figure 2	2 to 18	$\mu\text{s}$
Thermal Resistance, Junction to Lead	$R_{\theta JL}$	Between junction and pin	20 (max)	$^\circ\text{C/W}$

**Voltage Derating versus Ambient Temperature**

Power loss by reverse voltage not included

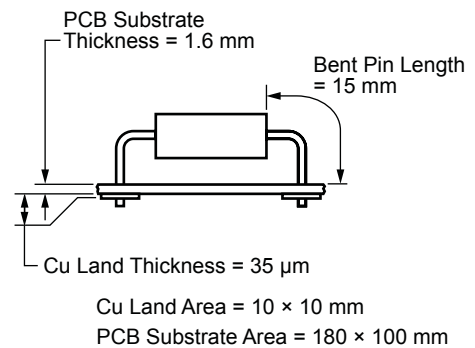
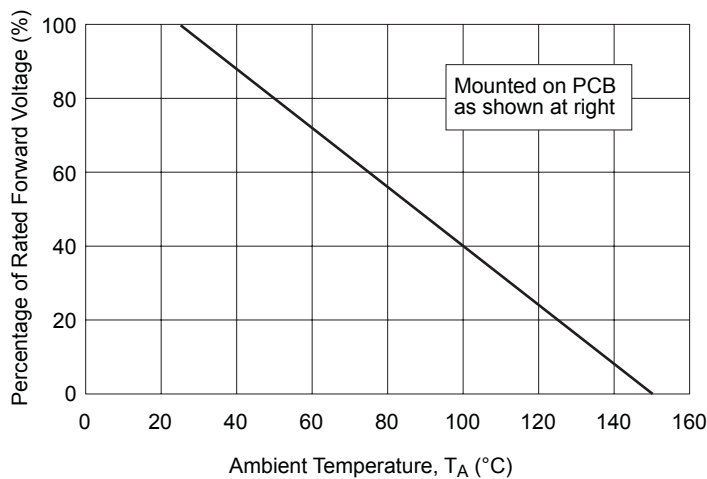

Figure 1. Derating Characteristic and Mounting Conditions

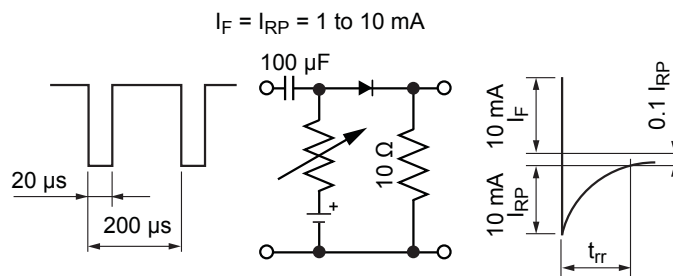
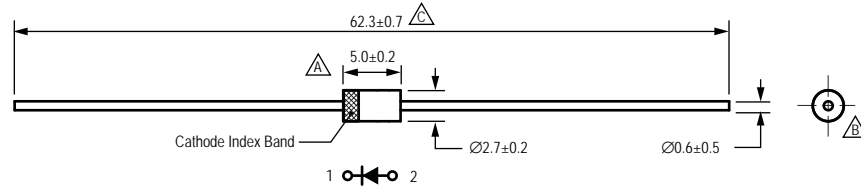

Figure 2. Definition of Peak Reverse Current,  $I_{RP}$

Package Outline



Dimensions in mm

- $\triangle A$  Offset body centerline to pin centerline 0.5 mm maximum
- $\triangle B$  Concentricity body and pin 0.3 mm maximum
- $\triangle C$  Pin dimension does not include trim burr; burr 2 mm maximum

Package Marking

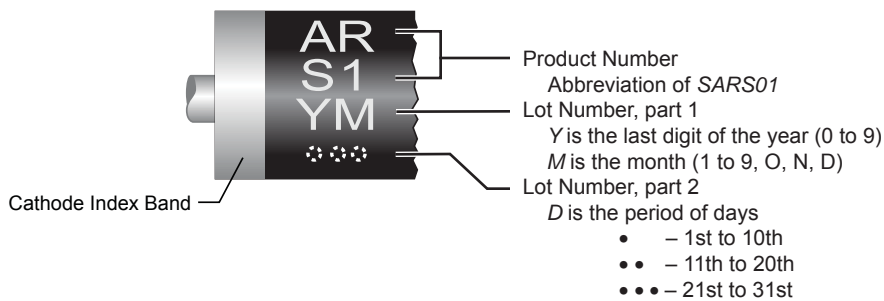

Material Composition and Internal Structure

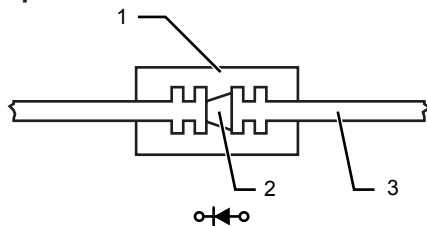

1. Body: Plastic, epoxy resin
2. Chip: Si
3. Pins: Cu wire  
Ag plating  
Solder dipped

Weight: Approximately 0.2 g



Pin treatment Pb-free. Device composition compliant with the RoHS directive.

Packing Options

V orientation

Axial taping  
5,000 pieces  
per reel

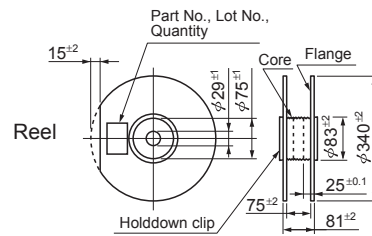
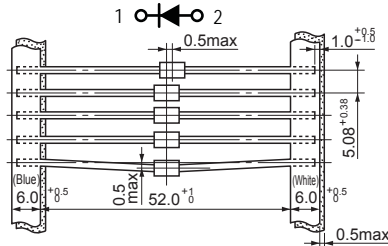

V1 orientation

Axial taping  
2,000 pieces  
per box

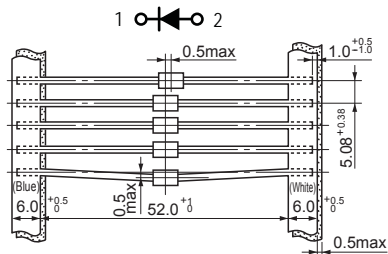

Ammunition  
(Ammo) pack

Broken lines:  
perforation

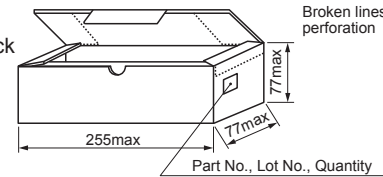

V0 orientation

Axial taping  
2,000 pieces  
per box

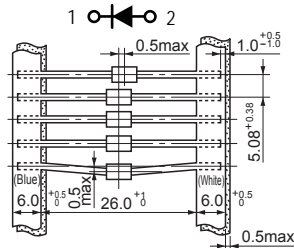

Ammunition  
(Ammo) pack

Broken lines:  
perforation

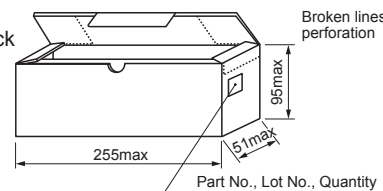

W orientation

Radial taping  
4,000 pieces  
per box

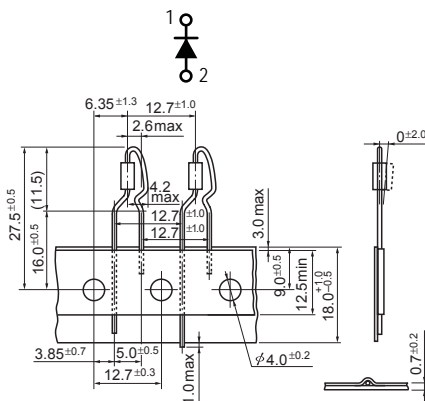

Dimensions in mm

Ammunition  
(Ammo) pack

Broken lines:  
perforation

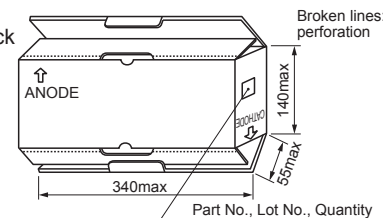

## Reliability Tests

Characteristic	Test Conditions	Acceptance Criterion	Rating	Unit
Thermal Fatigue Test	$\Delta T_j = 100^\circ\text{C}$	1	5000	cycle
High Temperature Reverse Bias Test	$T_A = 150^\circ\text{C}$ , $V_R = V_{RM}$ (AC, half-sine wave)	1	1000	hour
Humidity Reverse Bias Test	$T_A = 85^\circ\text{C}$ , RH = 85%, $V_R = V_{RM} \times 0.8$ (DC)	1	500	hour
High Temperature Storage Test	$T_A = 150^\circ\text{C}$	1	1000	hour
Moisture Resistance Test	$T_A = 85^\circ\text{C}$ , RH = 85%	1	1000	hour
Thermal Shock Test	Ice water (5 minutes), then boiling water (5 minutes)	1	100	cycle
Temperature Cycle Test	$-40^\circ\text{C}$ (30 minutes), then room temperature (5 minutes), then $150^\circ\text{C}$ (30 minutes)	1	100	cycle
Pressure Cooker Test	$2.03 \times 10^5$ Pa, 100% RH, unsaturated equipment	1	48	hour
Resistance to Soldering Heat Test	$260 \pm 5^\circ\text{C}$ , solder dip to 1.5 mm from body	1	10	second
	$380 \pm 5^\circ\text{C}$ , using soldering iron	1	3.5	second
Solderability Test	$245 \pm 5^\circ\text{C}$ , $5 \pm 0.5$ seconds, using rosin flux	2	95	%
Pin Bend Test	Apply EIAJ ED-4701/400	3	2	cycle
Pin Pull Test		3	10	second
Pin Twist Test		3	2	cycle
Drop Test		3	10	cycle

NOTE: Acceptance criteria as follows:

- 1 – Product meets all the values specified in the Electrical Characteristics table, after being exposed to normal temperature more than 2 hours and less than 24 hours.
- 2 – Product meets rating of the reliability test.
- 3 – No structural failures during reliability test, and product meets  $V_F$  and  $I_R$  specifications in the Electrical Characteristics table after completion of the reliability test.

## Design Notes

Use resistors in series, and adjust so the diode saturates at junction temperature,  $T_j \leq 150^\circ\text{C}$ .

- 
- The contents in this document are subject to changes, for improvement and other purposes, without notice. Make sure that this is the latest revision of the document before use.
  - Application and operation examples described in this document are quoted for the sole purpose of reference for the use of the products herein and Sanken can assume no responsibility for any infringement of industrial property rights, intellectual property rights or any other rights of Sanken or any third party which may result from its use.
  - Although Sanken undertakes to enhance the quality and reliability of its products, the occurrence of failure and defect of semiconductor products at a certain rate is inevitable. Users of Sanken products are requested to take, at their own risk, preventative measures including safety design of the equipment or systems against any possible injury, death, fires or damages to the society due to device failure or malfunction.
  - Sanken products listed in this document are designed and intended for the use as components in general purpose electronic equipment or apparatus (home appliances, office equipment, telecommunication equipment, measuring equipment, etc.).

When considering the use of Sanken products in the applications where higher reliability is required (transportation equipment and its control systems, traffic signal control systems or equipment, fire/crime alarm systems, various safety devices, etc.), and whenever long life expectancy is required even in general purpose electronic equipment or apparatus, please contact your nearest Sanken sales representative to discuss, prior to the use of the products herein.

The use of Sanken products without the written consent of Sanken in the applications where extremely high reliability is required (aerospace equipment, nuclear power control systems, life support systems, etc.) is strictly prohibited.

- In the case that you use Sanken products or design your products by using Sanken products, the reliability largely depends on the degree of derating to be made to the rated values. Derating may be interpreted as a case that an operation range is set by derating the load from each rated value or surge voltage or noise is considered for derating in order to assure or improve the reliability. In general, derating factors include electric stresses such as electric voltage, electric current, electric power etc., environmental stresses such as ambient temperature, humidity etc. and thermal stress caused due to self-heating of semiconductor products. For these stresses, instantaneous values, maximum values and minimum values must be taken into consideration.

In addition, it should be noted that since power devices or IC's including power devices have large self-heating value, the degree of derating of junction temperature affects the reliability significantly.

- When using the products specified herein by either (i) combining other products or materials therewith or (ii) physically, chemically or otherwise processing or treating the products, please duly consider all possible risks that may result from all such uses in advance and proceed therewith at your own responsibility.
- Anti radioactive ray design is not considered for the products listed herein.
- Sanken assumes no responsibility for any troubles, such as dropping products caused during transportation out of Sanken's distribution network.
- The contents in this document must not be transcribed or copied without Sanken's written consent.