

High power NPN transistor

Features

- High power dissipation
- Low collector-emitter saturation voltage

Description

The device is a planar NPN transistor mounted in TO-3 metal case. It is intended for linear amplifiers and inductive switching applications.

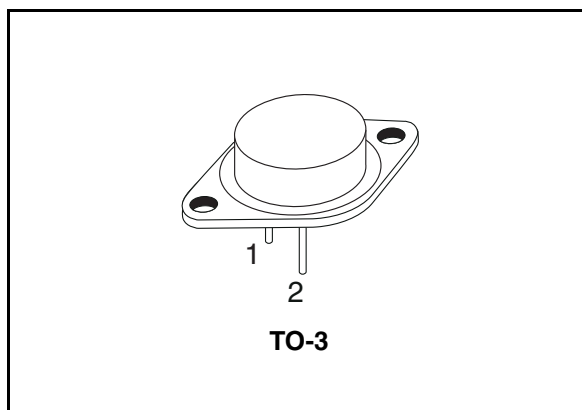

Figure 1. Internal schematic diagram

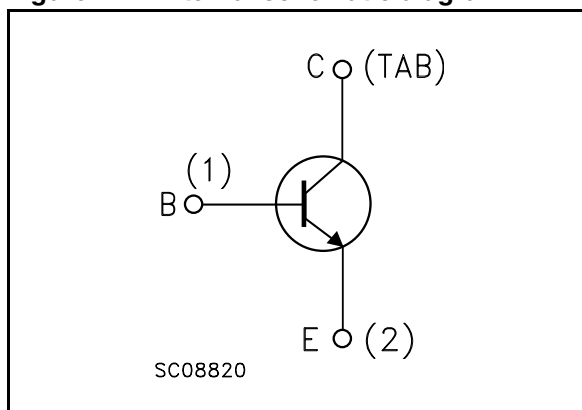

Table 1. Device summary

Order code	Marking	Package	Packaging
2N3773	2N3773	TO-3	Tray

1 Electrical ratings

Table 2. Absolute maximum ratings

Symbol	Parameter	Value	Unit
V_{CEO}	Collector-emitter voltage ($I_B = 0$)	140	V
V_{CEV}	Collector-emitter voltage ($V_{BE} = -1.5$ V)	160	V
V_{CBO}	Collector-base voltage ($I_E = 0$)	160	V
V_{EBO}	Emitter-base voltage ($I_C = 0$)	7	V
I_C	Collector current	16	A
I_{CM}	Collector peak current ($t_P < 5$ ms)	30	A
I_B	Base current	4	A
I_{BM}	Base peak current ($t_P < 1$ ms)	15	A
P_{tot}	Total dissipation at $T_C \leq 25$ °C	150	W
T_{stg}	Storage temperature	-65 to 200	°C
T_j	Max. operating junction temperature	200	°C

Table 3. Thermal data

Symbol	Parameter	Value	Unit
$R_{thj-case}$	Thermal resistance junction-case Max	1.17	°C/W

2 Electrical characteristics

($T_{\text{case}} = 25\text{ °C}$ unless otherwise specified)

Table 4. Electrical characteristics

Symbol	Parameter	Test conditions	Min.	Typ.	Max.	Unit
I_{CEV}	Collector cut-off current ($V_{\text{BE}} = -1.5\text{ V}$)	$V_{\text{CE}} = 140\text{ V}$ $V_{\text{CE}} = 140\text{ V}$ $T_{\text{C}} = 150\text{ °C}$			2 10	mA mA
I_{CEO}	Collector cut-off current ($I_{\text{B}} = 0$)	$V_{\text{CE}} = 120\text{ V}$			10	mA
I_{CBO}	Collector cut-off current ($I_{\text{E}} = 0$)	$V_{\text{CB}} = 140\text{ V}$			2	mA
I_{EBO}	Emitter cut-off current ($I_{\text{C}} = 0$)	$V_{\text{EB}} = 7\text{ V}$			5	mA
$V_{\text{CEO(sus)}}^{(1)}$	Collector-emitter sustaining voltage ($I_{\text{B}} = 0$)	$I_{\text{C}} = 0.2\text{ A}$	140			V
$V_{\text{CEV(sus)}}^{(1)}$	Collector-emitter sustaining voltage ($V_{\text{BE}} = -1.5\text{ V}$)	$I_{\text{C}} = 0.1\text{ A}$	160			V
$V_{\text{CER(sus)}}^{(1)}$	Collector-emitter sustaining voltage ($R_{\text{BE}} = 100\ \Omega$)	$I_{\text{C}} = 0.2\text{ A}$	150			V
$V_{\text{CE(sat)}}^{(1)}$	Collector-emitter saturation voltage	$I_{\text{C}} = 8\text{ A}$ $I_{\text{B}} = 0.8\text{ A}$ $I_{\text{C}} = 16\text{ A}$ $I_{\text{B}} = 3.2\text{ A}$			1.4 4	V V
$V_{\text{BE}}^{(1)}$	Base-emitter voltage	$I_{\text{C}} = 8\text{ A}$ $V_{\text{CE}} = 4\text{ V}$			2.2	V
$h_{\text{FE}}^{(1)}$	DC current gain	$I_{\text{C}} = 8\text{ A}$ $V_{\text{CE}} = 4\text{ V}$ $I_{\text{C}} = 16\text{ A}$ $V_{\text{CE}} = 4\text{ V}$	15 5		60	
$I_{\text{s/b}}$	Second Breakdown Collector Current	$V_{\text{CE}} = 30\text{ V}$ $t = 1\text{ s}$ (non repetitive)	5			A

1. Pulsed: Pulse duration = 300 μs , duty cycle $\leq 2\%$

3 Package mechanical data

In order to meet environmental requirements, ST offers these devices in ECOPACK® packages. These packages have a Lead-free second level interconnect. The category of second level interconnect is marked on the package and on the inner box label, in compliance with JEDEC Standard JESD97. The maximum ratings related to soldering conditions are also marked on the inner box label. ECOPACK is an ST trademark.

TO-3 mechanical data

DIM.	mm.		
	min.	typ	max.
A	11.00		13.10
B	0.97		1.15
C	1.50		1.65
D	8.32		8.92
E	19.00		20.00
G	10.70		11.10
N	16.50		17.20
P	25.00		26.00
R	4.00		4.09
U	38.50		39.30
V	30.00		30.30

