

## HIGH POWER NPN SILICON TRANSISTOR

- STMicroelectronics PREFERRED SALESTYPE
- NPN TRANSISTOR
- HIGH VOLTAGE CAPABILITY
- HIGH CURRENT CAPABILITY
- FAST SWITCHING SPEED

### APPLICATIONS

- SWITCH MODE POWER SUPPLIES
- FLYBACK AND FORWARD SINGLE TRANSISTOR LOW POWER CONVERTERS

### DESCRIPTION

The 2N6547 is a silicon Multiepitaxial Mesa NPN transistor mounted in TO-3 metal case. It is particularly intended for switching and industrial applications from single and three-phase mains.

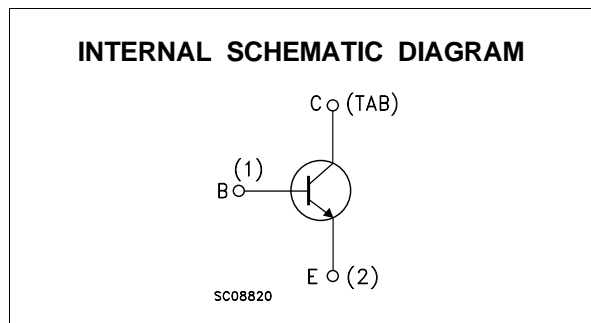
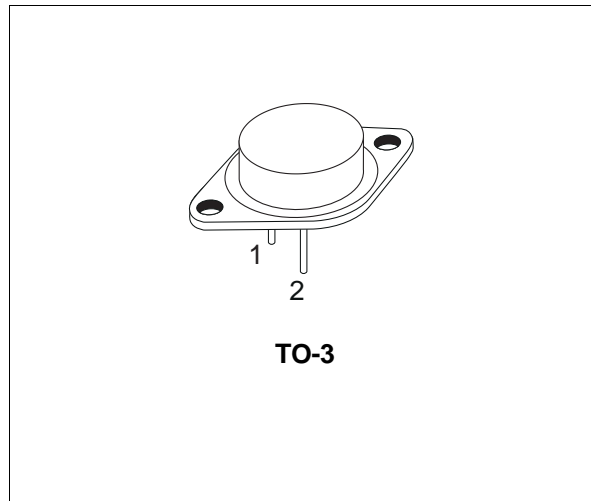

### ABSOLUTE MAXIMUM RATINGS

Symbol	Parameter	Value	Unit
$V_{CER}$	Collector-Emitter Voltage ( $R_{BE} = 50 \Omega$ )	850	V
$V_{CES}$	Collector-Emitter Voltage ( $V_{BE} = 0$ )	850	V
$V_{CEO}$	Collector-Emitter Voltage ( $I_B = 0$ )	400	V
$V_{EBO}$	Emitter-Base Voltage ( $I_C = 0$ )	9	V
$I_C$	Collector Current	15	A
$I_{CM}$	Collector Peak Current	30	A
$I_B$	Base Current	4	A
$I_{BM}$	Base Peak Current	20	A
$P_{tot}$	Total Dissipation at $T_c = 25^\circ C$	175	W
$T_{stg}$	Storage Temperature	-65 to 200	$^\circ C$
$T_j$	Max. Operating Junction Temperature	200	$^\circ C$

## THERMAL DATA

R <sub>thj-case</sub>	Thermal Resistance Junction-case	Max	1	°C/W
-----------------------	----------------------------------	-----	---	------

ELECTRICAL CHARACTERISTICS (T<sub>case</sub> = 25 °C unless otherwise specified)

Symbol	Parameter	Test Conditions	Min.	Typ.	Max.	Unit
I <sub>CES</sub>	Collector Cut-off Current (V <sub>BE</sub> = 0)	V <sub>CE</sub> = 850 V V <sub>CE</sub> = 850 V T <sub>c</sub> = 100 °C			1 4	mA mA
I <sub>CER</sub>	Collector Cut-off Current (R <sub>BE</sub> = 10 Ω)	V <sub>CE</sub> = 850 V T <sub>c</sub> = 100 °C			5	mA
I <sub>EBO</sub>	Emitter Cut-off Current (I <sub>C</sub> = 0)	V <sub>EB</sub> = 9 V			1	mA
V <sub>CEO(sus)*</sub>	Collector-Emitter Sustaining Voltage (I <sub>B</sub> = 0)	I <sub>C</sub> = 100 mA L = 25 mH	400			V
V <sub>CE(sat)*</sub>	Collector-Emitter Saturation Voltage	I <sub>C</sub> = 10 A I <sub>B</sub> = 2 A I <sub>C</sub> = 15 A I <sub>B</sub> = 3 A I <sub>C</sub> = 10A I <sub>B</sub> = 2 A T <sub>c</sub> = 100 °C			1.5 5 2.5	V V V
V <sub>BE(sat)*</sub>	Base-Emitter Saturation Voltage	I <sub>C</sub> = 10 A I <sub>B</sub> = 2 A I <sub>C</sub> = 10A I <sub>B</sub> = 2 A T <sub>c</sub> = 100 °C			1.6 1.6	V V
h <sub>FE*</sub>	DC Current Gain	I <sub>C</sub> = 5 A V <sub>CE</sub> = 2 V I <sub>C</sub> = 10 A V <sub>CE</sub> = 2 V	12 6		30	
f <sub>T*</sub>	Transition Frequency	I <sub>C</sub> = 0.5 A V <sub>CE</sub> = 10 V f = 1 MHz	6		24	MHz
C <sub>CB0</sub>	Collector-Base Capacitance (I <sub>E</sub> = 0)	V <sub>CB</sub> = 10 V f = 1 MHz			360	pF

\* Pulsed: Pulse duration = 300 μs, duty cycle ≤ 2 %

## RESISTIVE LOAD SWITCHING TIMES

Symbol	Parameter	Test Conditions	Min.	Typ.	Max.	Unit
t <sub>on</sub>	Turn-on Time	V <sub>CC</sub> = 250 V I <sub>C</sub> = 10 A			1	μs
t <sub>s</sub>	Storage Time	I <sub>B1</sub> = - I <sub>B2</sub> = 2 A T <sub>p</sub> ≥ 25 μs			4	μs
t <sub>f</sub>	Fall Time				0.7	μs

## INDUCTIVE LOAD SWITCHING TIMES

Symbol	Parameter	Test Conditions	Min.	Typ.	Max.	Unit
t <sub>s</sub>	Storage Time	V <sub>CL</sub> = 450 V I <sub>C</sub> = 10 A			5	μs
t <sub>f</sub>	Fall Time	L <sub>C</sub> = 180 μH I <sub>B1</sub> = 2 A V <sub>BE</sub> = -5 V T <sub>c</sub> = 100 °C			1.5	μs

## TO-3 MECHANICAL DATA

DIM.	mm			inch		
	MIN.	TYP.	MAX.	MIN.	TYP.	MAX.
A	11.00		13.10	0.433		0.516
B	0.97		1.15	0.038		0.045
C	1.50		1.65	0.059		0.065
D	8.32		8.92	0.327		0.351
E	19.00		20.00	0.748		0.787
G	10.70		11.10	0.421		0.437
N	16.50		17.20	0.649		0.677
P	25.00		26.00	0.984		1.023
R	4.00		4.09	0.157		0.161
U	38.50		39.30	1.515		1.547
V	30.00		30.30	1.187		1.193

