



2STL1360

LOW VOLTAGE FAST-SWITCHING NPN POWER TRANSISTOR

Features

- VERY LOW COLLECTOR-EMITTER SATURATION VOLTAGE
- HIGH CURRENT GAIN CHARACTERISTIC
- FAST-SWITCHING SPEED
- IN COMPLIANCE WITH THE 2002/93/EC EUROPEAN DIRECTIVE

Applications

- EMERGENCY LIGHTING
- LED
- CCFL DRIVERS (BACK LIGHTING)
- VOLTAGE REGULATION
- RELAY DRIVER

Description

The 2STX1360 is a NPN transistor manufactured using new "PB-HDC" (Power Bipolar High Density Current) technology. The resulting transistor shows exceptional high gain performances coupled with very low saturation voltage.

DATA BRIEF

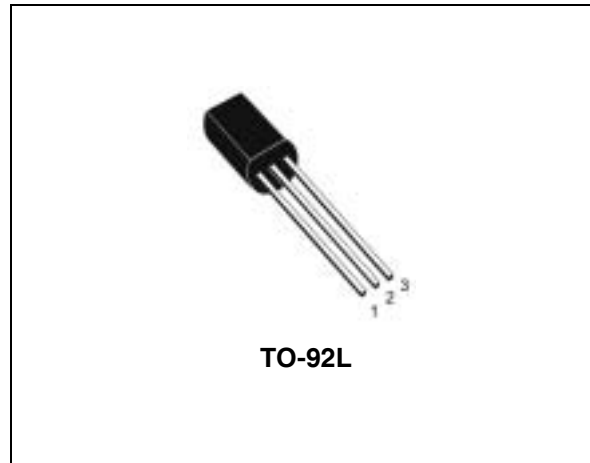

Internal Schematic Diagram

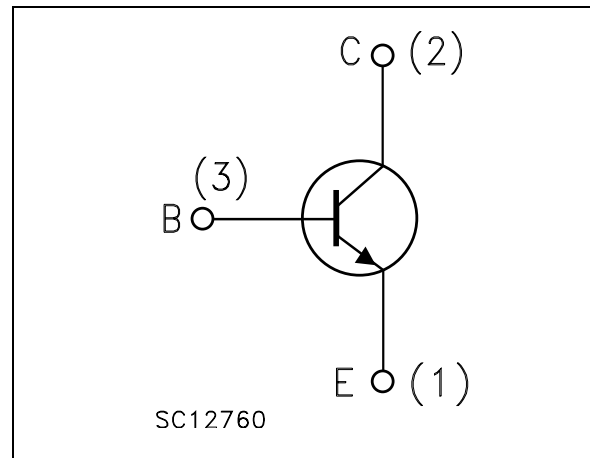

Order Codes

Part Number	Marking	Package	Packing
2STL1360	L1360	TO-92L	Bulk

Information furnished is believed to be accurate and reliable. However, STMicroelectronics assumes no responsibility for the consequences of use of such information nor for any infringement of patents or other rights of third parties which may result from its use. No license is granted by implication or otherwise under any patent or patent rights of STMicroelectronics. Specifications mentioned in this publication are subject to change without notice. This publication supersedes and replaces all information previously supplied. STMicroelectronics products are not authorized for use as critical components in life support devices or systems without express written approval of STMicroelectronics.

The ST logo is a registered trademark of STMicroelectronics.
All other names are the property of their respective owners

© 2005 STMicroelectronics - All rights reserved

STMicroelectronics group of companies

Australia - Belgium - Brazil - Canada - China - Czech Republic - Finland - France - Germany - Hong Kong - India - Israel - Italy - Japan -
Malaysia - Malta - Morocco - Singapore - Spain - Sweden - Switzerland - United Kingdom - United States of America

www.st.com