

SINGLE INVERTER OPEN DRAIN

- 5V TOLERANT INPUTS
- HIGH SPEED: $t_{PD} = 4.2\text{ns}$ (MAX.) at $V_{CC} = 3\text{V}$
- LOW POWER DISSIPATION:
 $I_{CC} = 1\mu\text{A}$ (MAX.) at $T_A = 25^\circ\text{C}$
- POWER DOWN PROTECTION ON INPUTS AND OUTPUTS
- OPERATING VOLTAGE RANGE:
 $V_{CC}(\text{OPR}) = 1.65\text{V}$ to 5.5V
(1.2V Data Retention)
- IMPROVED LATCH-UP IMMUNITY

DESCRIPTION

The 74LX1G05 is a low voltage CMOS SINGLE INVERTER (OPEN DRAIN) fabricated with sub-micron silicon gate and double-layer metal wiring C²MOS technology.

The internal circuit is composed of 3 stages including buffer output, which provide high noise immunity and stable output.

This device can also be used as a led driver in any other application requiring current sink.

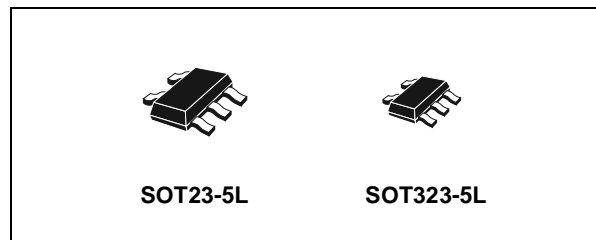

ORDER CODES

PACKAGE	T & R
SOT23-5L	74LX1G05STR
SOT323-5L	74LX1G05CTR

Power down protection is provided on all inputs and 0 to 7V can be accepted on inputs with no regard to the supply voltage. This device can be used to interface 5V to 3V.

All inputs and outputs are equipped with protection circuits against static discharge.

PIN CONNECTION AND IEC LOGIC SYMBOLS

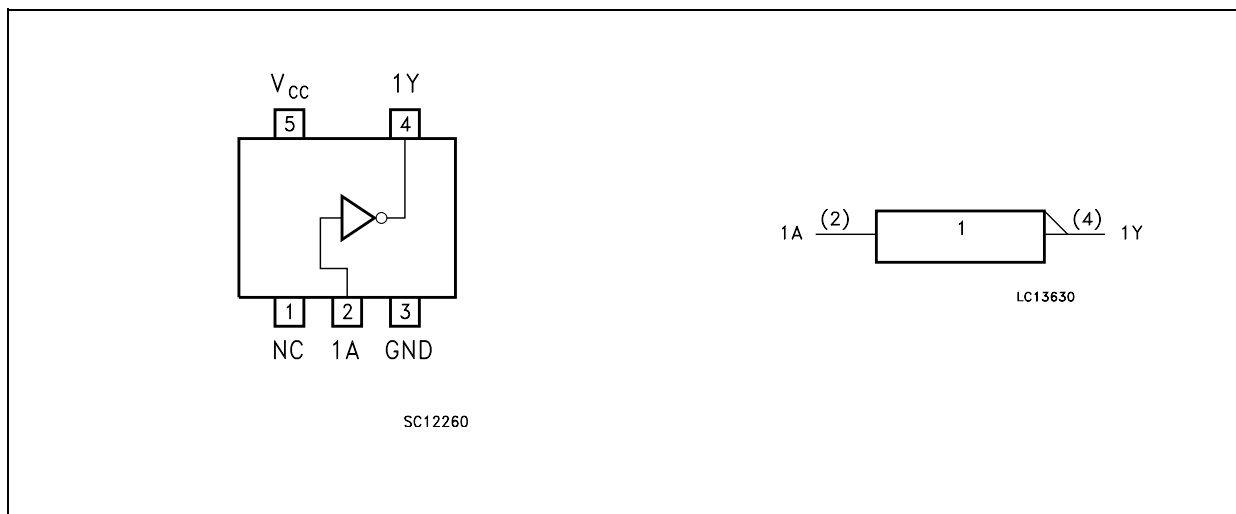

74LX1G05

INPUT EQUIVALENT CIRCUIT

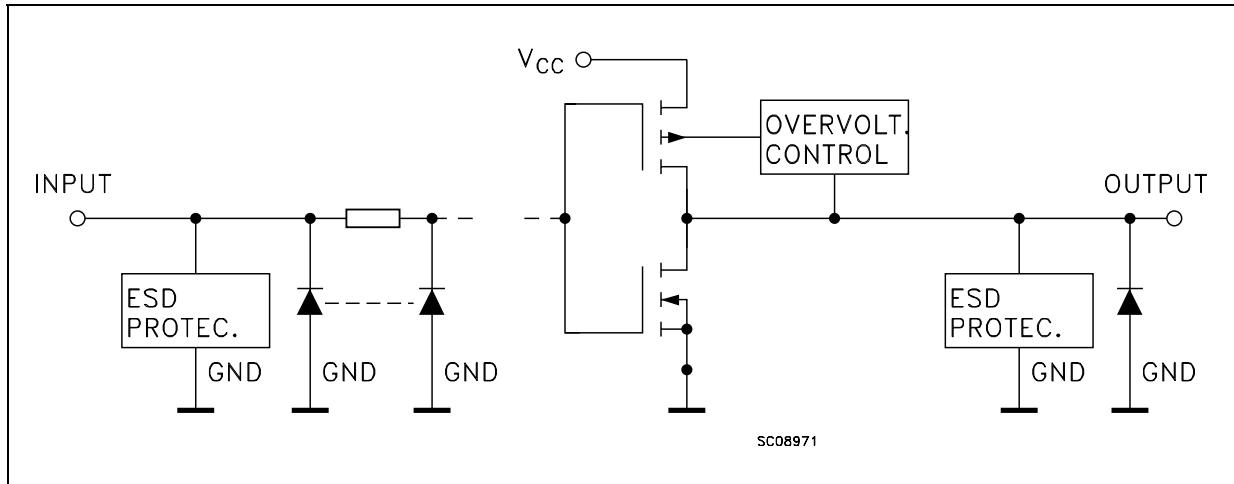

PIN DESCRIPTION

PIN N°	SYMBOL	NAME AND FUNCTION
1	NC	Not Connected
2	1A	Data Input
4	1Y	Data Output
3	GND	Ground (0V)
5	V _{CC}	Positive Supply Voltage

TRUTH TABLE

A	Y
L	Z
H	L

Z: High Impedance

ABSOLUTE MAXIMUM RATINGS

Symbol	Parameter	Value	Unit
V _{CC}	Supply Voltage	-0.5 to +7.0	V
V _I	DC Input Voltage	-0.5 to +7.0	V
V _O	DC Output Voltage (V _{CC} = 0V)	-0.5 to +7.0	V
V _O	DC Output Voltage (High or Low State) (note 1)	-0.5 to V _{CC} + 0.5	V
I _{IK}	DC Input Diode Current	- 50	mA
I _{OK}	DC Output Diode Current (note 2)	- 50	mA
I _O	DC Output Current	± 50	mA
I _{CC} or I _{GND}	DC V _{CC} or Ground Current per Supply Pin	± 50	mA
T _{stg}	Storage Temperature	-65 to +150	°C
T _L	Lead Temperature (10 sec)	300	°C

Absolute Maximum Ratings are those values beyond which damage to the device may occur. Functional operation under these conditions is not implied

1) I_O absolute maximum rating must be observed

2) V_O < GND, V_O > V_{CC}

RECOMMENDED OPERATING CONDITIONS

Symbol	Parameter	Value	Unit
V_{CC}	Supply Voltage (note 1)	1.65 to 5.5	V
V_I	Input Voltage	0 to 5.5	V
V_O	Output Voltage ($V_{CC} = 0V$)	0 to 5.5	V
V_O	Output Voltage (High or Low State)	0 to V_{CC}	V
I_{OL}	High or Low Level Output Current ($V_{CC} = 4.5$ to $5.5V$)	+ 32	mA
I_{OL}	High or Low Level Output Current ($V_{CC} = 3.0$ to $3.6V$)	+ 24	mA
I_{OL}	High or Low Level Output Current ($V_{CC} = 2.7$ to $3.0V$)	+ 12	mA
I_{OL}	High or Low Level Output Current ($V_{CC} = 2.3$ to $2.7V$)	+ 8	mA
I_{OL}	High or Low Level Output Current ($V_{CC} = 1.65$ to $2.3V$)	+ 4	mA
T_{op}	Operating Temperature	-55 to 125	°C
dt/dv	Input Rise and Fall Time (note 2)	0 to 10	ns/V

1) Truth Table guaranteed: 1.2V to 3.6V

2) V_{IN} from 0.8V to 2V at $V_{CC} = 3.0V$

DC SPECIFICATIONS

Symbol	Parameter	Test Condition		Value				Unit
		V_{CC} (V)		-40 to 85 °C		-55 to 125 °C		
				Min.	Max.	Min.	Max.	
V_{IH}	High Level Input Voltage	1.65 to 1.95		$0.75V_{CC}$		$0.75V_{CC}$		V
		2.3 to 2.7		$0.7V_{CC}$		$0.7V_{CC}$		
		3.0 to 5.5		$0.7V_{CC}$		$0.7V_{CC}$		
V_{IL}	Low Level Input Voltage	1.65 to 1.95			$0.25V_{CC}$		$0.25V_{CC}$	V
		2.3 to 2.7			$0.3V_{CC}$		$0.3V_{CC}$	
		3.0 to 5.5			$0.3V_{CC}$		$0.3V_{CC}$	
V_{OL}	Low Level Output Voltage	1.65 to 4.5	$I_O=100 \mu A$		0.1		0.1	V
		1.65	$I_O=4 \text{ mA}$		0.45		0.45	
		2.3	$I_O=8 \text{ mA}$		0.3		0.3	
		3.0	$I_O=16 \text{ mA}$		0.4		0.4	
			$I_O=24 \text{ mA}$		0.55		0.55	
4.5	$I_O=32 \text{ mA}$		0.55		0.55			
I_{OZ}	High Impedance Output Leakage Current	3.6	$V_I = 0$ to $5.5V$		± 10		± 10	μA
I_I	Input Leakage Current	1.65 to 5.5	$V_I = 0$ to $5.5V$		± 10		± 10	μA
I_{off}	Power Off Leakage Current	0	V_I or $V_O = 5.5V$		10		10	μA
I_{CC}	Quiescent Supply Current	1.65 to 5.5	$V_I = V_{CC}$ or GND		10		10	μA
		3.6	V_I or $V_O = 3.6$ to $5.5V$		± 10		± 10	

AC ELECTRICAL CHARACTERISTICS

Symbol	Parameter	Test Condition				Value				Unit
		V _{CC} (V)	C _L (pF)	R _L (Ω)	t _s = t _r (ns)	-40 to 85 °C		-55 to 125 °C		
						Min.	Max.	Min.	Max.	
t _{PLZ}	Propagation Delay Time	1.65 to 1.95	30	1000	2.0	2.4	8.3	2.4	8.3	ns
		2.3 to 2.7	30	500	2.0	1.0	5.5	1.0	5.5	
		2.7	50	500	2.5	1.0	5.5	1.0	5.5	
		3.0 to 3.6	50	500	2.5	1.5	4.2	1.5	4.2	
		4.5 to 5.5	50	500	2.5	1	3.5	1	3.5	
t _{PZL}	Propagation Delay Time	1.65 to 1.95	30	1000	2.0	2.4	8.3	2.4	8.3	ns
		2.3 to 2.7	30	500	2.0	1.0	5.5	1.0	5.5	
		2.7	50	500	2.5	1.0	5.5	1.0	5.5	
		3.0 to 3.6	50	500	2.5	1.5	4.2	1.5	4.2	
		4.5 to 5.5	50	500	2.5	1	3.5	1	3.5	

CAPACITIVE CHARACTERISTICS

Symbol	Parameter	Test Condition		Value			Unit
		V _{CC} (V)		T _A = 25 °C			
				Min.	Typ.	Max.	
C _{IN}	Input Capacitance		V _{IN} = 0 or V _{CC}		4		pF
C _{OUT}	Output Capacitance		V _{IN} = 0 or V _{CC}		5	10	pF
C _{PD}	Power Dissipation Capacitance (note 1)	1.8	f _{IN} = 10MHz		21		pF
		2.5			24		
		3.3			26		

1) C_{PD} is defined as the value of the IC's internal equivalent capacitance which is calculated from the operating current consumption without load. (Refer to Test Circuit). Average operating current can be obtained by the following equation. I_{CC(oper)} = C_{PD} × V_{CC} × f_{IN} + I_{CC}

TEST CIRCUIT

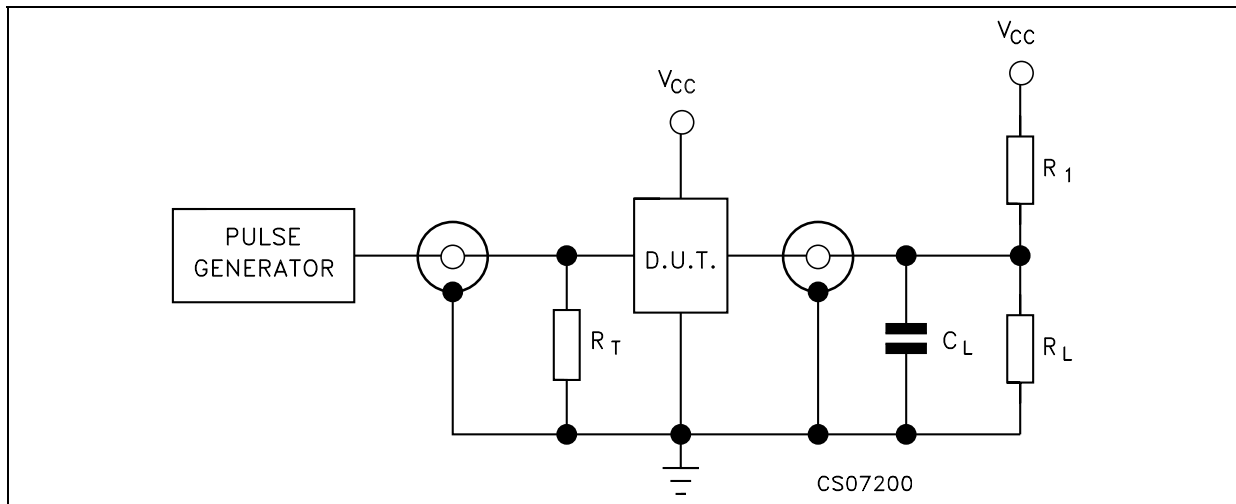

$R_T = Z_{OUT}$ of pulse generator (typically 50Ω)

TEST CIRCUIT AND WAVEFORM SYMBOL VALUE

Symbol	V_{CC}		
	1.65 to 1.95V	2.3 to 2.7V	2.7 to 5.5V
C_L	30pF/50pF	30pF/50pF	50pF
$R_L = R_1$	1000Ω	500Ω	500Ω
V_{IH}	V_{CC}	V_{CC}	V_{CC}
V_M	$V_{CC}/2$	$V_{CC}/2$	$V_{CC}/2$
$t_r = t_f$	$<2.0ns$	$<2.0ns$	$<2.5ns$

WAVEFORM: PROPAGATION DELAY ($f=1MHz$; 50% duty cycle)

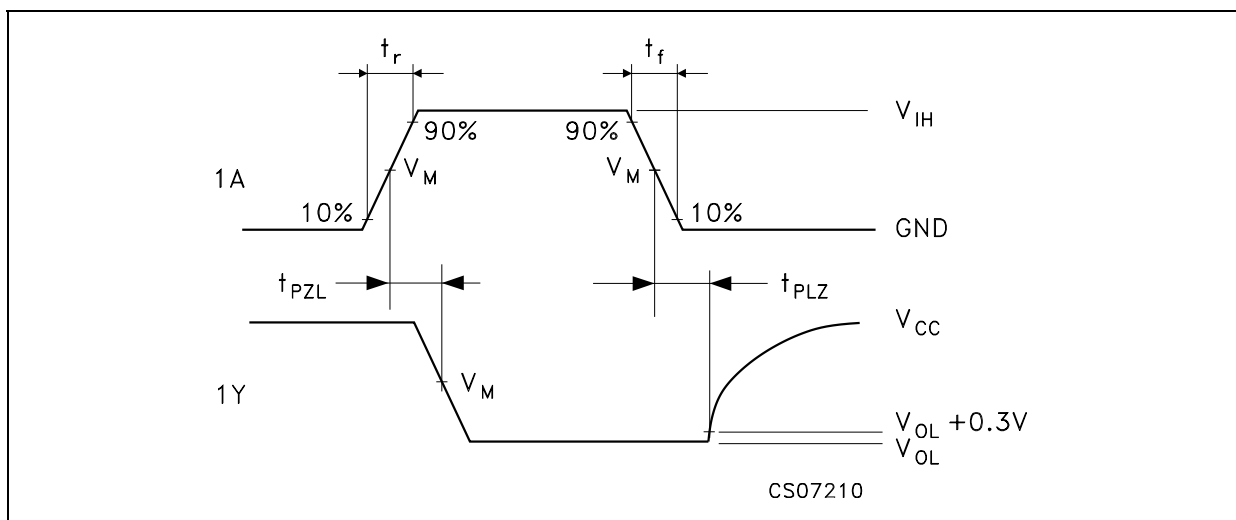

SOT23-5L MECHANICAL DATA

DIM.	mm.			mils		
	MIN.	TYP	MAX.	MIN.	TYP.	MAX.
A	0.90		1.45	35.4		57.1
A1	0.00		0.10	0.0		3.9
A2	0.90		1.30	35.4		51.2
b	0.35		0.50	13.7		19.7
C	0.09		0.20	3.5		7.8
D	2.80		3.00	110.2		118.1
E	1.50		1.75	59.0		68.8
e		0.95			37.4	
H	2.60		3.00	102.3		118.1
L	0.10		0.60	3.9		23.6

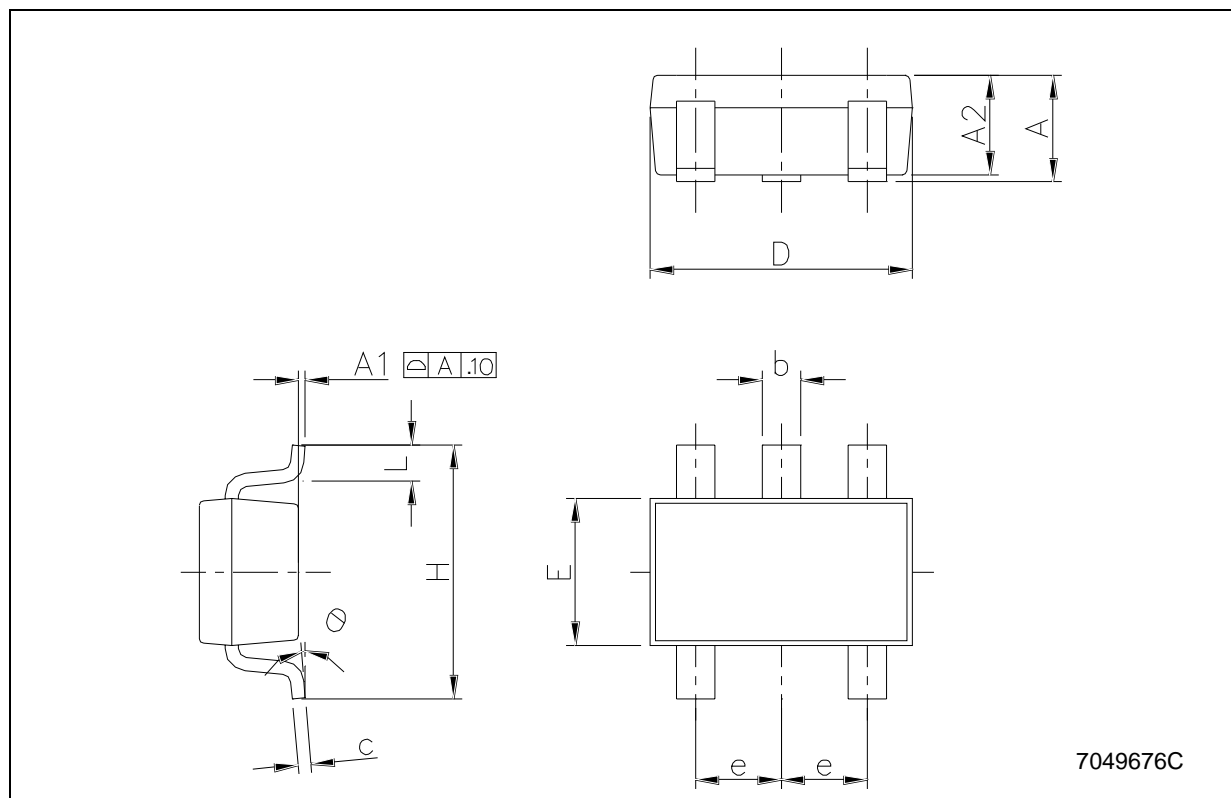

SOT323-5L MECHANICAL DATA

DIM.	mm.			mils		
	MIN.	TYP	MAX.	MIN.	TYP.	MAX.
A	0.80		1.10	31.5		43.3
A1	0.00		0.10	0.0		3.9
A2	0.80		1.00	31.5		39.4
b	0.15		0.30	5.9		11.8
C	0.10		0.18	3.9		7.1
D	1.80		2.20	70.9		86.6
E	1.80		2.40	70.9		94.5
E1	1.15		1.35	45.3		53.1
e		0.65			25.6	
e1		1.3			51.2	
L	0.10		0.30	3.9		11.8

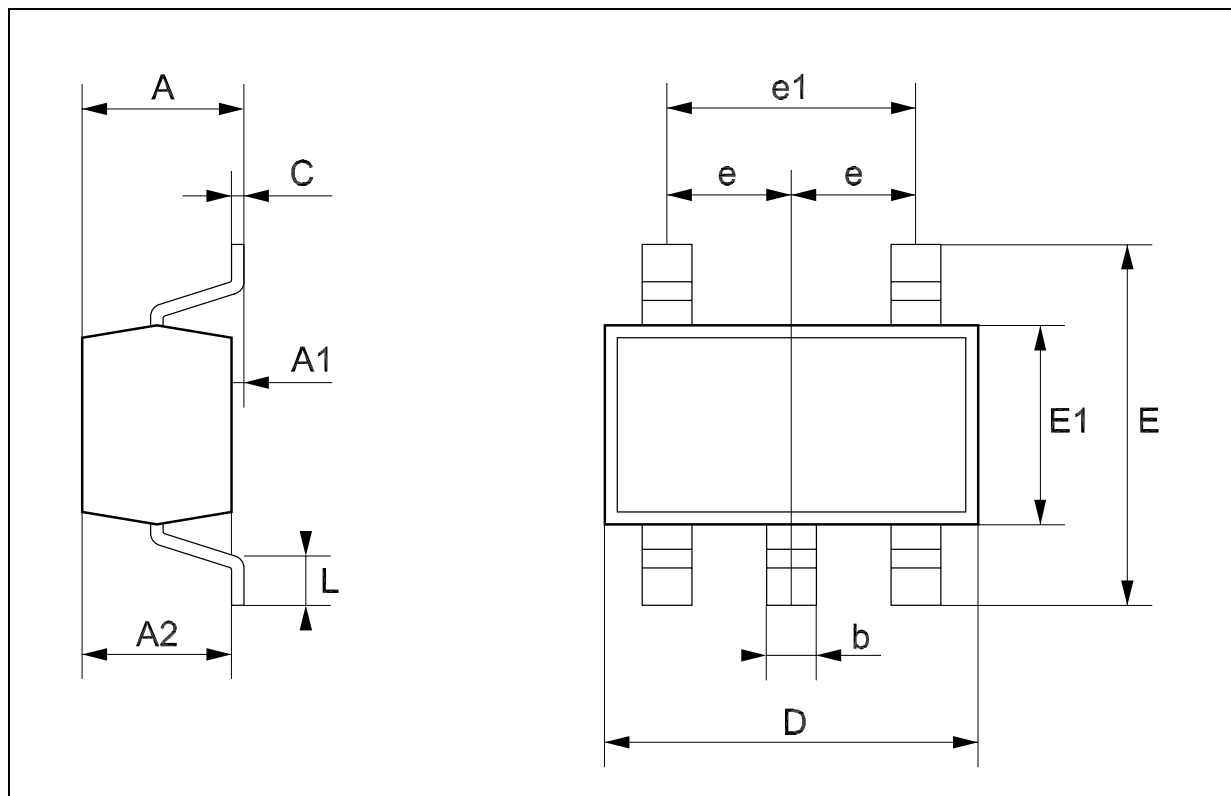

Tape & Reel SOT23-xL MECHANICAL DATA

DIM.	mm.			inch		
	MIN.	TYP	MAX.	MIN.	TYP.	MAX.
A			180			7.086
C	12.8	13.0	13.2	0.504	0.512	0.519
D	20.2			0.795		
N	60			2.362		
T			14.4			0.567
Ao	3.13	3.23	3.33	0.123	0.127	0.131
Bo	3.07	3.17	3.27	0.120	0.124	0.128
Ko	1.27	1.37	1.47	0.050	0.054	0.058
Po	3.9	4.0	4.1	0.153	0.157	0.161
P	3.9	4.0	4.1	0.153	0.157	0.161

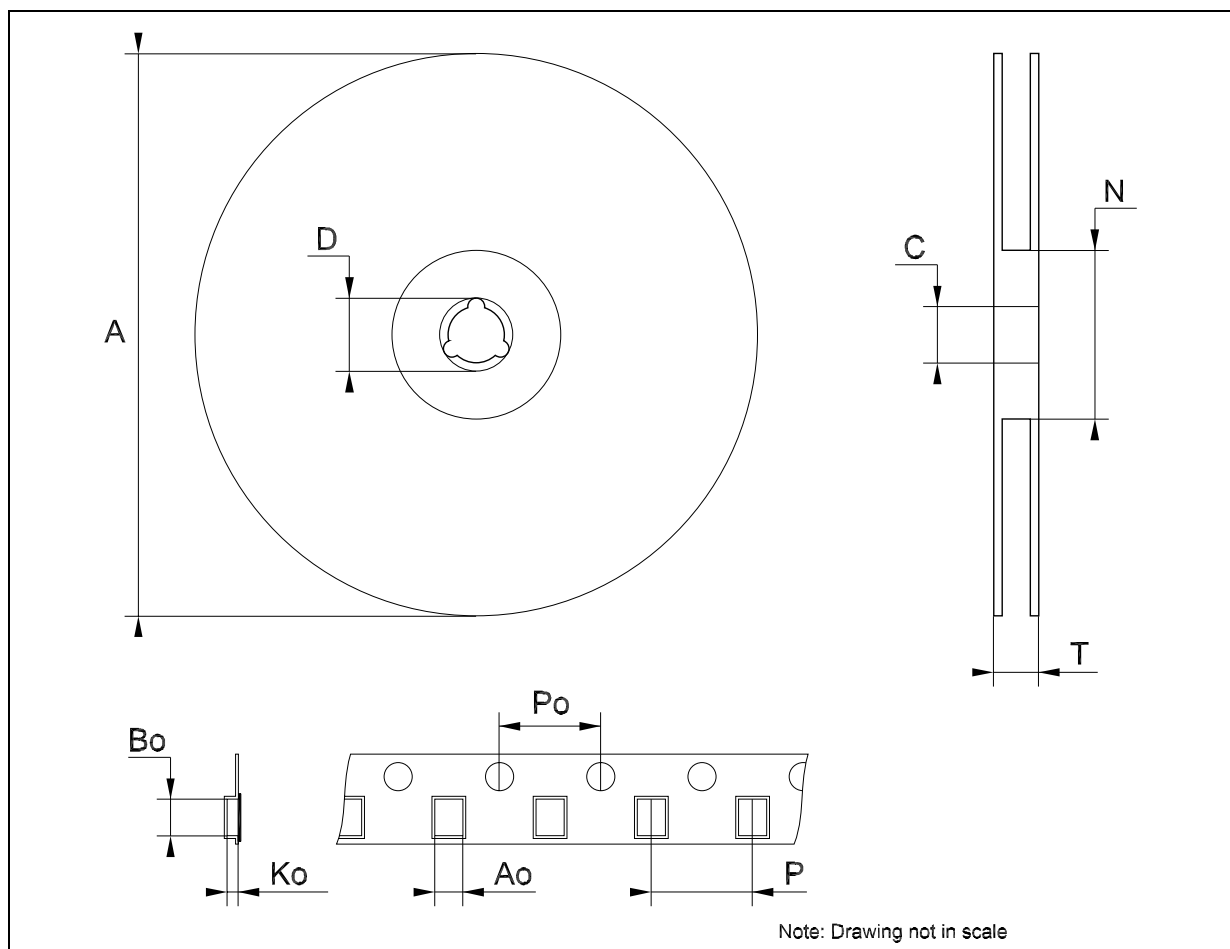

Tape & Reel SOT323-xL MECHANICAL DATA

DIM.	mm.			inch		
	MIN.	TYP	MAX.	MIN.	TYP.	MAX.
A	175	180	185	6.889	7.086	7.283
C	12.8	13	13.2	0.504	0.512	0.519
D	20.2			0.795		
N	59.5	60	60.5		2.362	
T			14.4			0.567
Ao		2.25			0.088	
Bo		2.7			0.106	
Ko		1.2			0.047	
Po	3.9	4	4.1	0.153	0.157	0.161
P	3.8	4	4.2	0.149	0.157	0.165

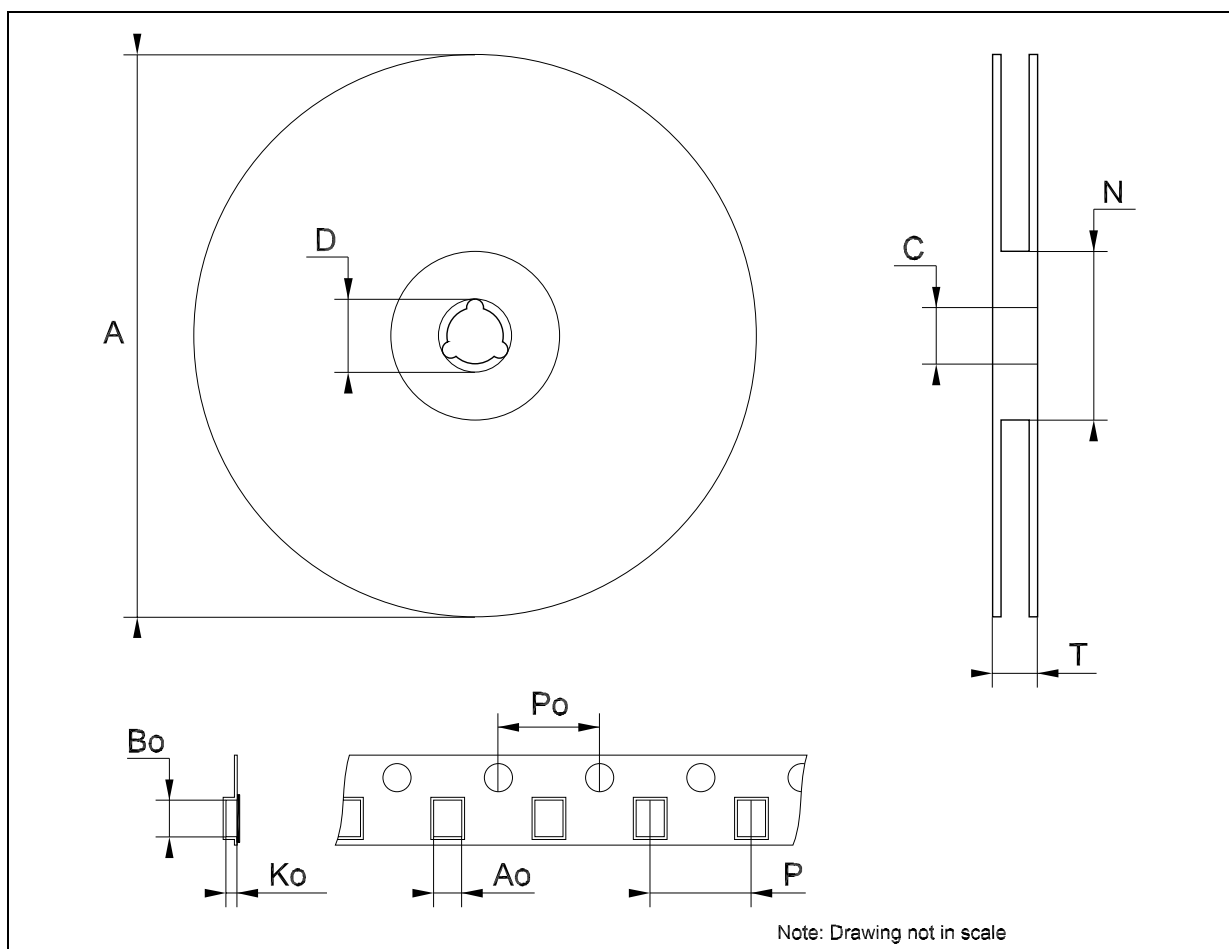

Information furnished is believed to be accurate and reliable. However, STMicroelectronics assumes no responsibility for the consequences of use of such information nor for any infringement of patents or other rights of third parties which may result from its use. No license is granted by implication or otherwise under any patent or patent rights of STMicroelectronics. Specifications mentioned in this publication are subject to change without notice. This publication supersedes and replaces all information previously supplied. STMicroelectronics products are not authorized for use as critical components in life support devices or systems without express written approval of STMicroelectronics.

The ST logo is a registered trademark of STMicroelectronics
All other names are the property of their respective owners

© 2004 STMicroelectronics - All Rights Reserved
STMicroelectronics GROUP OF COMPANIES

Australia - Belgium - Brazil - Canada - China - Czech Republic - Finland - France - Germany - Hong Kong - India - Israel - Italy - Japan -
Malaysia - Malta - Morocco - Singapore - Spain - Sweden - Switzerland - United Kingdom - United States.

<http://www.st.com>