

## Overvoltage protected AC switch

Datasheet – production data

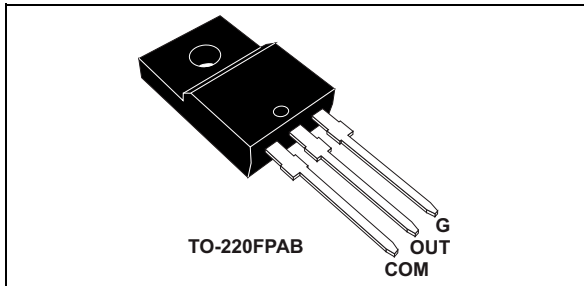

### Description

The ACST310-8FP belongs to the ACS™ / ACST power switch family built with A.S.D.® (application specific discrete) technology. This high performance device is suited to home appliances or industrial systems and drives loads up to 3 A.

This ACST310-8FP switch embeds a Triac structure and a high voltage clamping device able to absorb the inductive turn-off energy and withstand line transients such as those described in the IEC 61000-4-5 standard. The component needs a low gate current to be activated ( $I_{GT}$  max. 10 mA) and still shows a high electrical noise immunity complying with IEC standards such as IEC 61000-4-4 (fast transient burst test). It provides UL certified insulation rated at 2000  $V_{RMS}$  (file ref: E81734)

### Features

- AC switch with self over voltage protection
- Microcontroller direct driven (low gate current max. 10 mA)
- Three quadrants (Q1, Q2 and Q3)
- UL94-V0 qualified resin (flammability)
- Complies with UL standards UL 1557
  - Insulated voltage: 2000  $V_{RMS}$
- ECOPACK®2 compliant component

### Benefits

- Enables equipment to meet IEC61000-4-5
- High immunity against fast transients described in IEC61000-4-4 standard
- Needs no external overvoltage protection
- High off-state reliability power device
- Interfaces directly with the microcontroller
- Reduces component count

### Applications

- AC static switching in appliances and industrial control systems.
- Driving low power highly inductive loads or resistive AC loads, such as motor control circuits, small home appliances, lighting, fan speed controllers, water valves, pumps, solid state relays, vacuum cleaners, heater.

Figure 1. Functional diagram

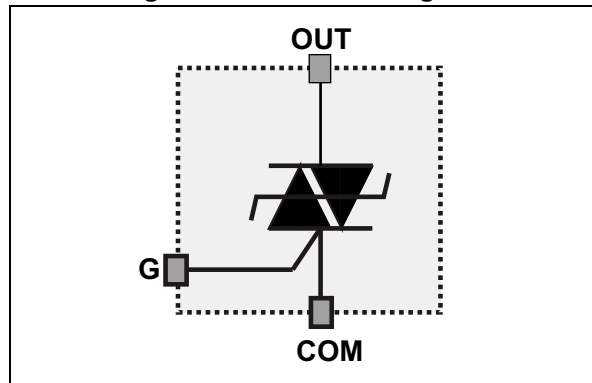

Table 1. Device summary

Symbol	Value	$V_{DRM}/V_{RRM}$
$I_{T(RMS)}$	3	A
$I_{GT(Q1, Q2, Q3)}$	10	mA
$V_{DRM}/V_{RRM}$	800	V

# 1 Characteristics

**Table 2. Absolute ratings (limiting values)**

Symbol	Parameter	Test conditions		Value	Unit
$I_{T(RMS)}$	On-state rms current (full sine wave)	$T_c = 98\text{ °C}$		3	A
$I_{TSM}$	Non repetitive surge peak on-state current ( $T_j$ initial = 25 °C)	f = 50 Hz	$t_p = 20\text{ ms}$	20	A
		f = 60 Hz	$t_p = 16.7\text{ ms}$	21	
$I^2t$	$I^2t$ value for fusing	$t_p = 10\text{ ms}$		2.6	A <sup>2</sup> s
dI/dt	Critical rate of rise of on-state current $I_G = 2 \times I_{GT}$ , $t_r = 100\text{ ns}$	f = 120 Hz	$T_j = 125\text{ °C}$	50	A/μs
$V_{PP}^{(1)}$	Non repetitive line peak mains voltage	$T_j = 25\text{ °C}$		2	kV
$P_{G(AV)}$	Average gate power dissipation	$T_j = 125\text{ °C}$		0.1	W
$P_{GM}$	Peak gate power	$t_p = 20\text{ μs}$	$T_j = 125\text{ °C}$	10	W
$I_{GM}$	Peak gate current	$t_p = 20\text{ μs}$	$T_j = 125\text{ °C}$	1.6	A
$T_{stg}$	Storage junction temperature range			-40 °C to +150 °C	°C
$T_j$	Operating junction temperature range			-40 °C to +125 °C	°C
$T_L$	Maximum lead temperature for soldering during 10 s (at 3 mm from plastic)			260	°C
$V_{INS(RMS)}$	Insulation rms voltage (60 seconds)			2000	V

1. according to test described by standard IEC 61000-4-5 (see [Figure 17](#) and [Figure 18](#)).

**Table 3. Electrical characteristics**

Symbol	Test conditions	Quadrant	$T_j$	Value		Unit
$I_{GT}^{(1)}$	$V_{OUT} = 12\text{ V}$ , $R_L = 33\text{ Ω}$	I - II - III	25 °C	MAX.	10	mA
$V_{GT}$				MAX.	1.1	V
$V_{GD}$	$V_{OUT} = V_{DRM}$ , $R_L = 3.3\text{ kΩ}$	I - II - III	125 °C	MIN.	0.2	V
$I_H^{(2)}$	$I_{OUT} = 100\text{ mA}$		25 °C	MAX.	20	mA
$I_L$	$I_G = 1.2 \times I_{GT}$	I - III	25 °C	MAX.	25	mA
		II			35	
$dV/dt^{(2)}$	$V_{OUT} = 67\% V_{DRM}$ , gate open		125 °C	MIN.	1000	V/μs
$(dI/dt)_c^{(2)}$	$(dV/dt)_c = 0.1\text{ V/μs}$		125 °C	MIN.	5	A/ms
$(dI/dt)_c^{(2)}$	$(dV/dt)_c = 10\text{ V/μs}$		125 °C	MIN.	1	A/ms
$V_{CL}$	$I_{CL} = 0.1\text{ mA}$ , $t_p = 1\text{ ms}$		25 °C	MIN.	850	V

1. Minimum  $I_{GT}$  is guaranteed at 5% of  $I_{GT}$  max.

2. For both polarities of OUT pin referenced to COM pin

Table 4. Static characteristics

Symbol	Test conditions	Value	Unit
$V_{TM}^{(1)}$	$I_{TM} = 4.2 \text{ A}$ , $t_p = 380 \mu\text{s}$	$T_j = 25 \text{ }^\circ\text{C}$	MAX. 1.8 V
$V_{to}^{(1)}$	Threshold voltage	$T_j = 125 \text{ }^\circ\text{C}$	MAX. 0.9 V
$R_d^{(1)}$	Dynamic resistance	$T_j = 125 \text{ }^\circ\text{C}$	MAX. 200 mΩ
$I_{DRM}$ $I_{RRM}$	$V_{OUT} = V_{DRM} / V_{RRM}$	$T_j = 25 \text{ }^\circ\text{C}$	MAX. 10 μA
		$T_j = 125 \text{ }^\circ\text{C}$	MAX. 500 μA

1. For both polarities of OUT pin referenced to COM pin

Table 5. Thermal characteristics

Symbol	Parameter	Value	Unit
$R_{th(j-c)}$	Junction to case (AC)	6.5	$^\circ\text{C/W}$
$R_{th(j-a)}$	Junction to ambient	60	$^\circ\text{C/W}$

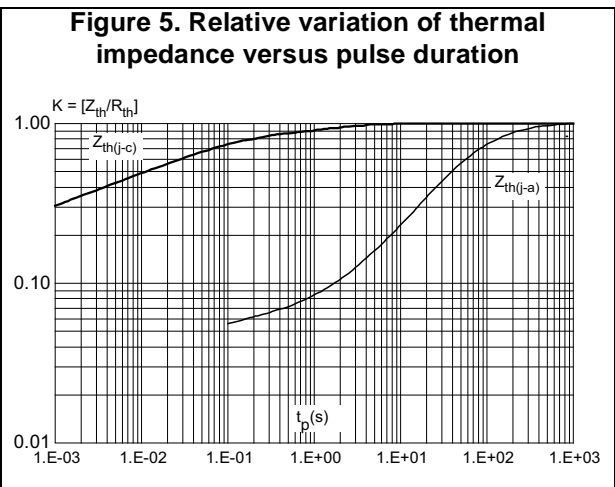
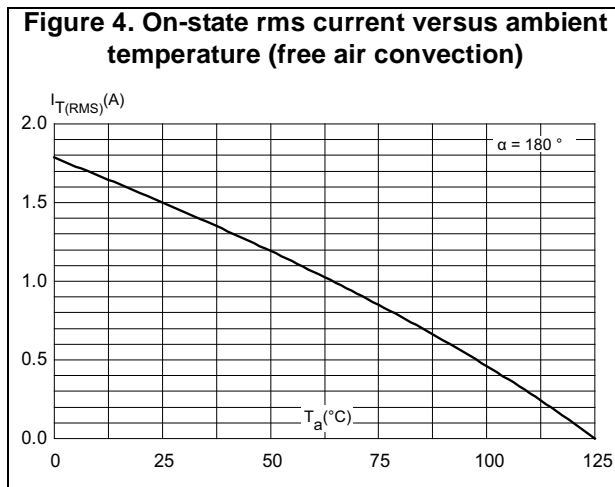
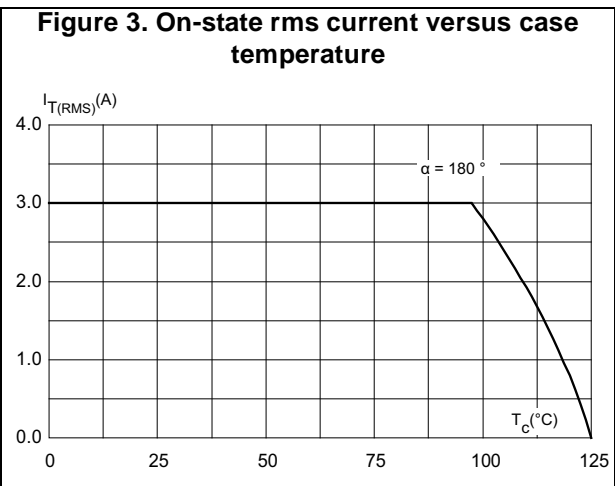
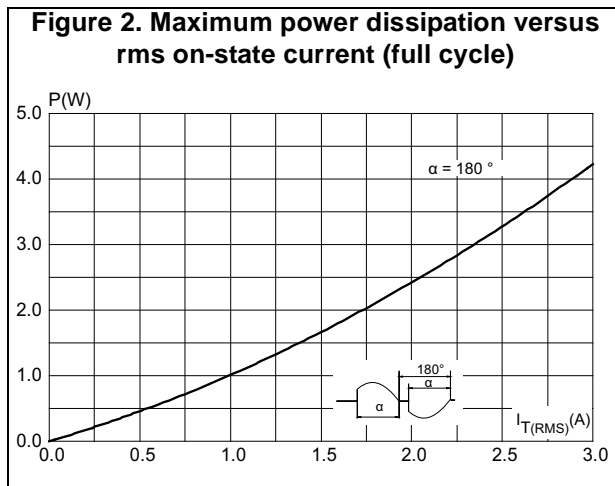

**Figure 6. Non repetitive surge peak on-state current for a sinusoidal pulse with width:  $t_p < 10\text{ms}$**

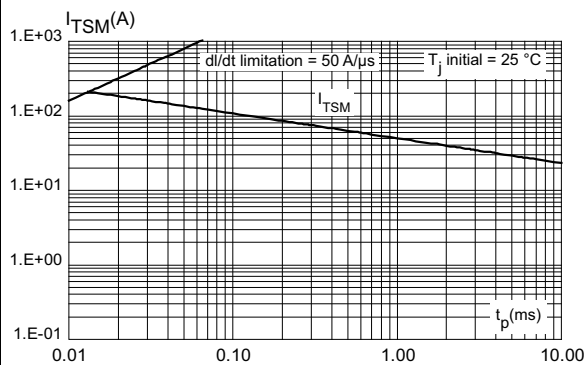

**Figure 7. Surge peak on-state current versus number of cycles**

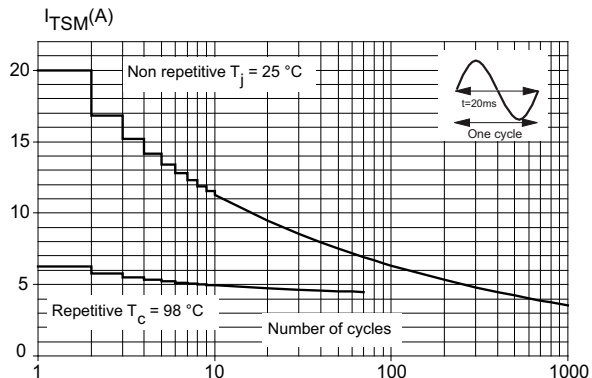

**Figure 8. Relative variation of holding current and latching current versus junction temperature (typical values)**

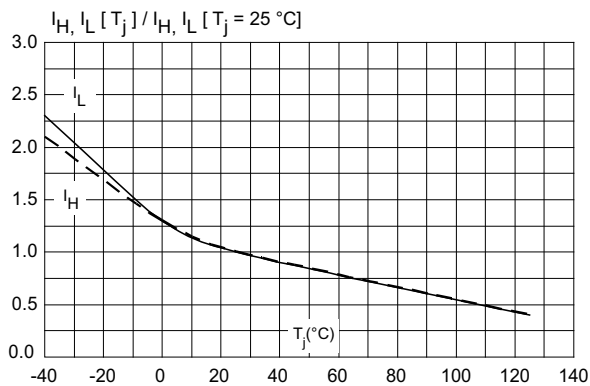

**Figure 9. Relative variation of gate trigger current and gate trigger voltage versus junction temperature (typical values)**

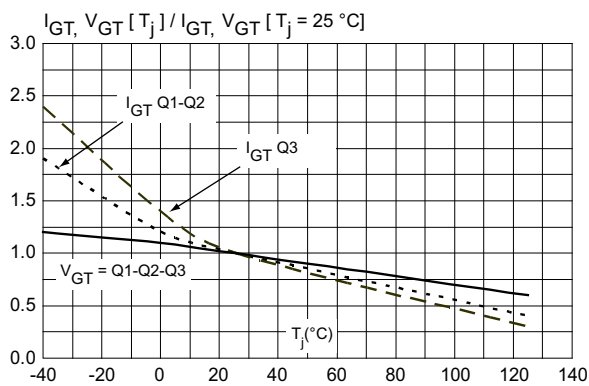

**Figure 10. On-state characteristics (maximum values)**

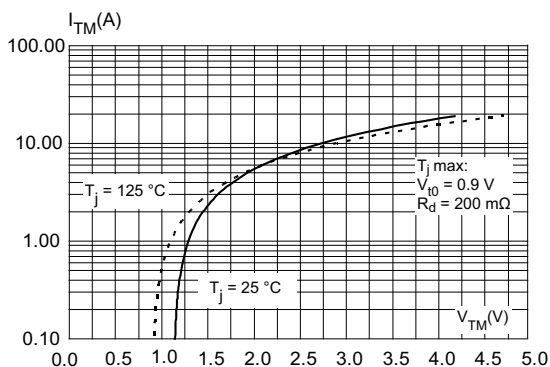

**Figure 11. Relative variation of critical rate of decrease of main current versus junction temperature (typical values)**

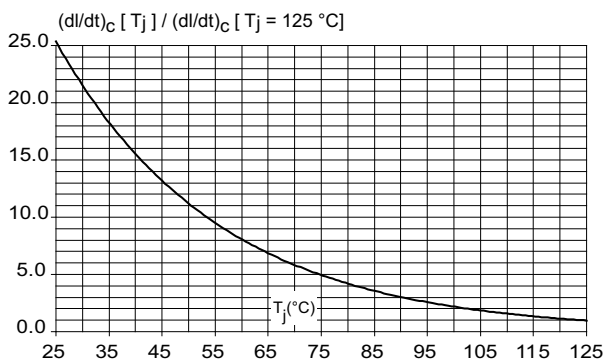

**Figure 12. Relative variation of static dV/dt immunity versus junction temperature**

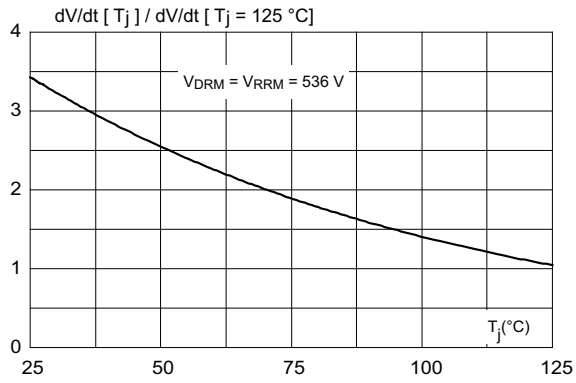

**Figure 13. Relative variation of leakage current versus junction temperature (typical values)**

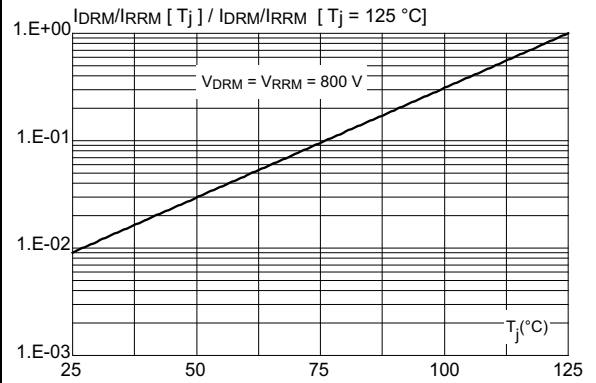

**Figure 14. Relative variation of critical rate of decrease of main current versus reapplied (dV/dt)**

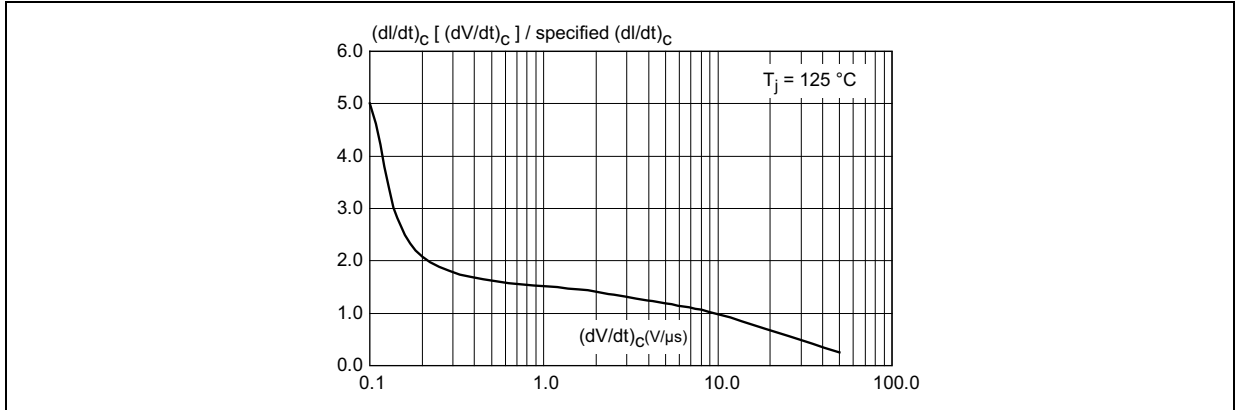

## 2 Application information

### 2.1 Typical application description

The ACST310 device has been designed to switch on and off, or by phase angle control, highly inductive or resistive loads such as pump, valve, fan, or bulb lamps. Thanks to its high sensitivity ( $I_{GT} \text{ max} = 10 \text{ mA}$ ), the ACST310 can be driven directly by logic level circuits through a resistor as shown on the typical application diagram (*Figure 15*).

Figure 15. AC induction motor control - typical diagram

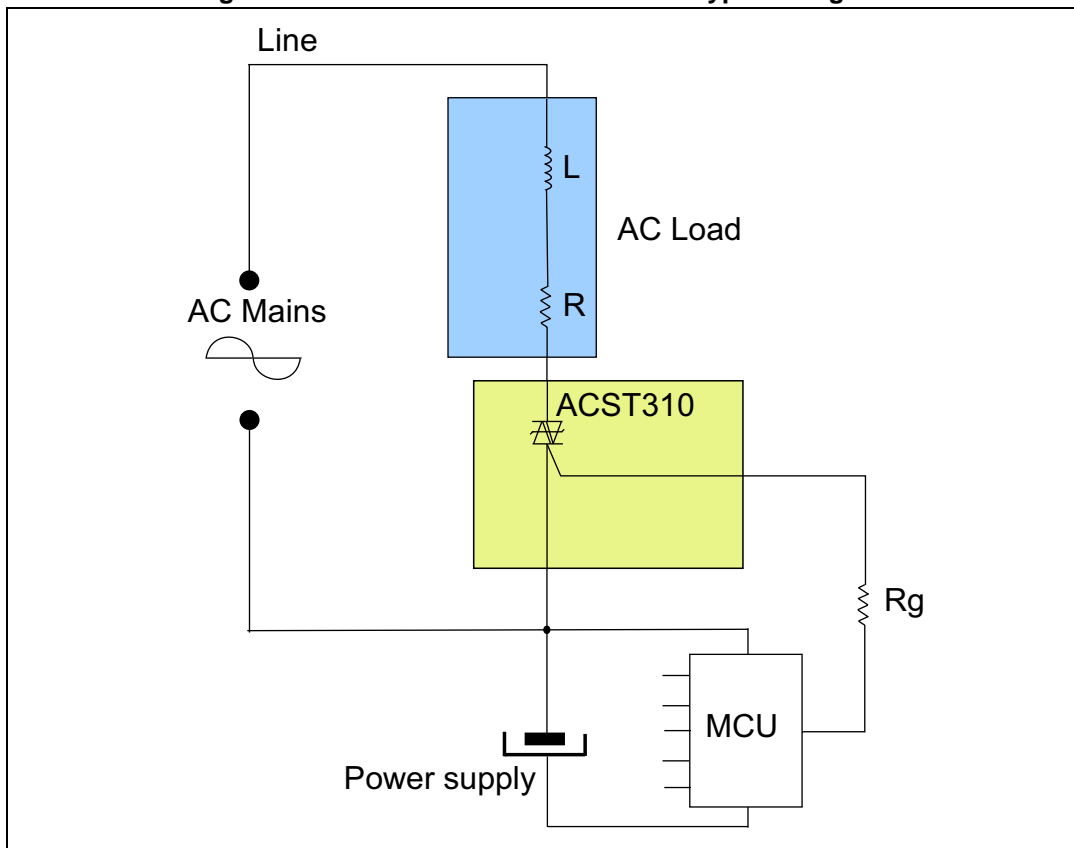
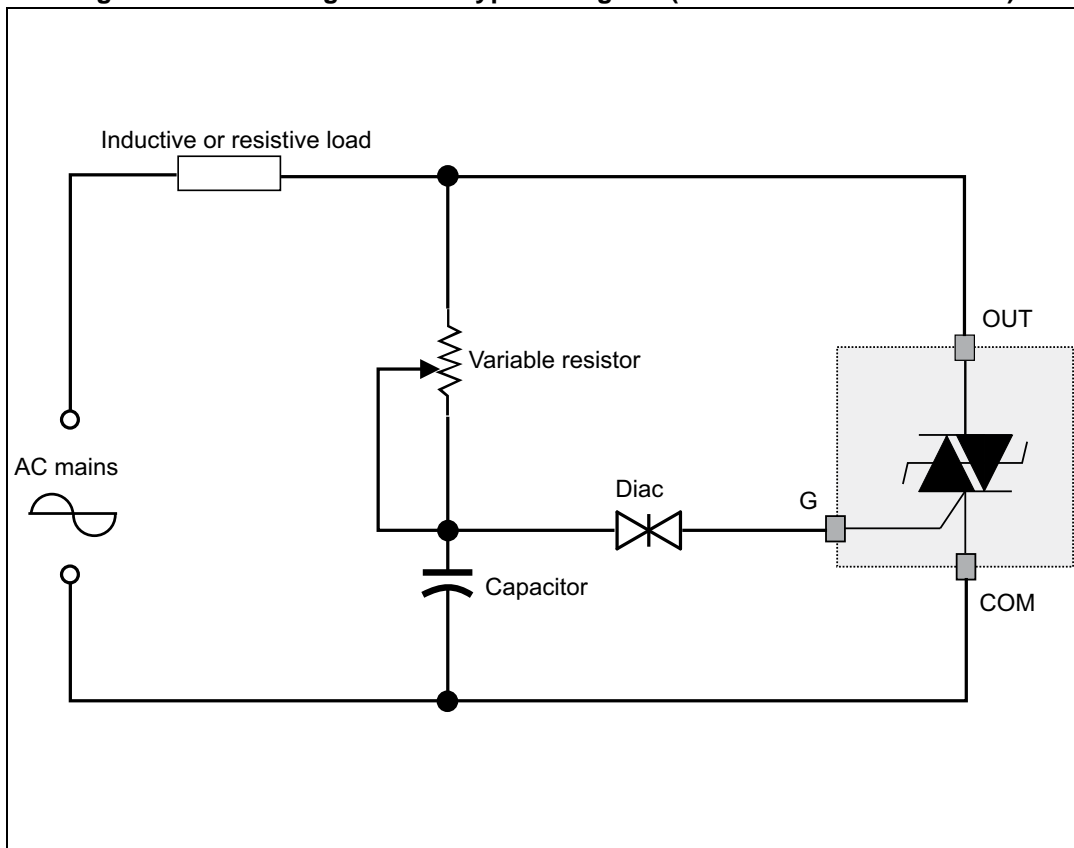

Figure 16. Phase angle control typical diagram (inductive or resistive load)



## 2.2 AC line transient voltage ruggedness

In comparison with standard Triacs, which are not robust against surge voltage, the ACST310 is self-protected against over-voltage, specified by the parameter  $V_{CL}$ . In addition, the ACST310 is a sensitive device ( $I_{GT}$  max. 10 mA), but provides a high noise immunity level against fast transients. The ACST310 switch can safely withstand AC line transient voltages either by clamping the low energy spikes, such as inductive spikes at switch off, or by switching to the on state (for less than 10 ms) to dissipate higher energy shocks through the load. This safety feature works even with high turn-on current ramp up.

The test circuit of [Figure 17](#) represents the ACST310 application, and is used to stress the ACST310 switch according to the IEC 61000-4-5 standard conditions. With the additional effect of the load which is limiting the current, the ACST310 switch withstands the voltage spikes up to 2 kV on top of the peak line voltage. The protection is based on an overvoltage crowbar technology. The ACST310 folds back safely to the on state as shown in [Figure 18](#). The ACST310 recovers its blocking voltage capability after the surge and the next zero current crossing. Such a non-repetitive test can be done at least 10 times on each AC line voltage polarity.

**Figure 17. Overvoltage ruggedness test circuit for resistive and inductive loads for IEC 61000-4-5 standards**

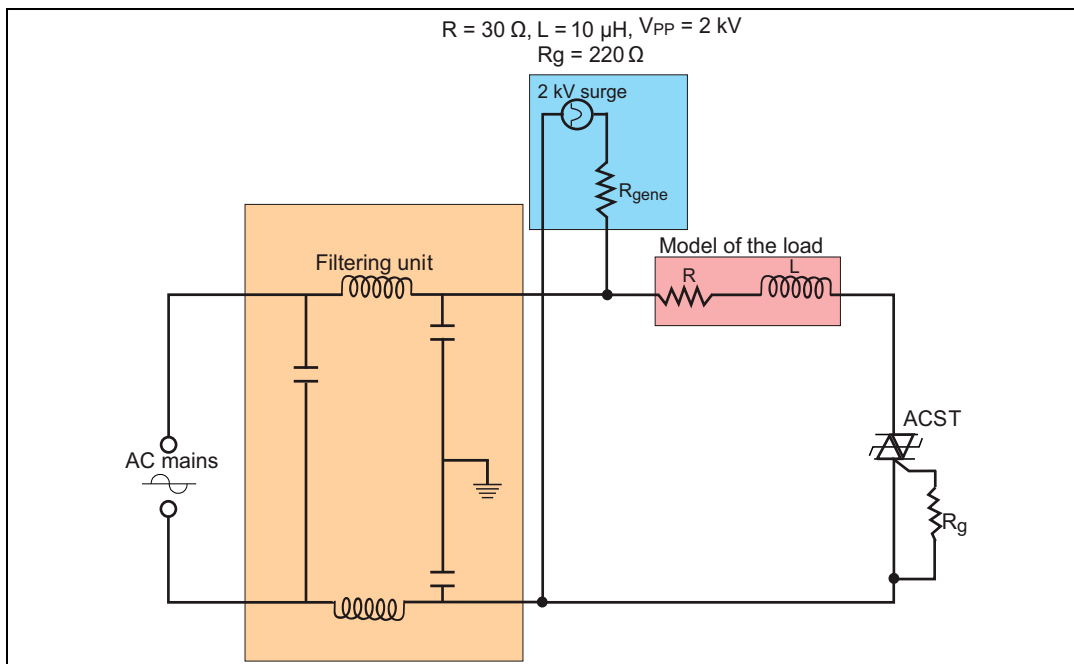

**Figure 18. Typical voltage and current waveforms across the ACST310-8FP during IEC 61000-4-5 standard test**

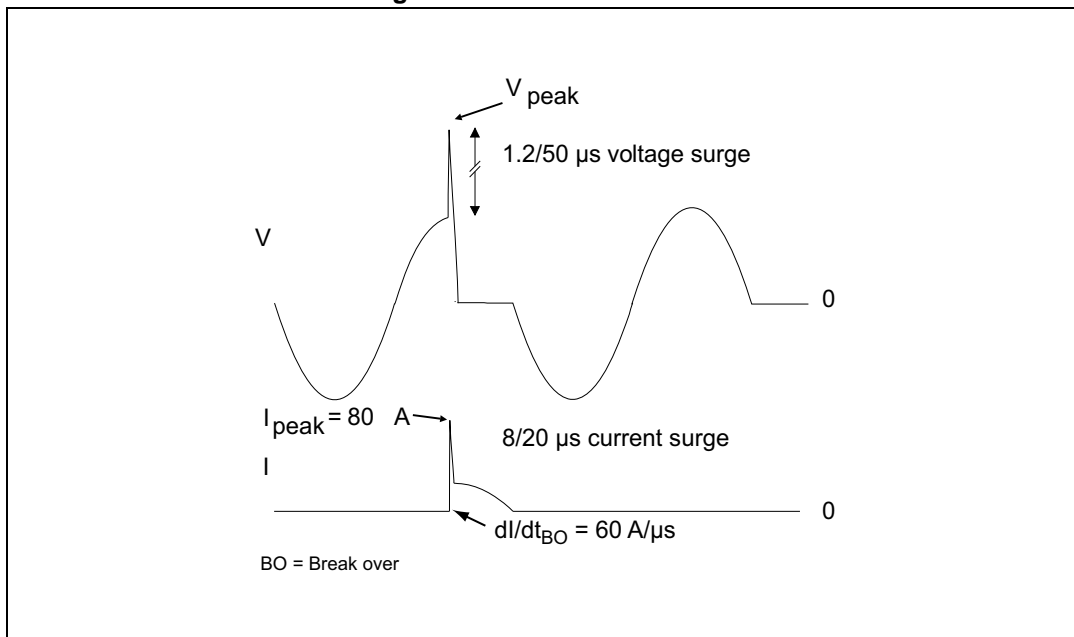

## 2.3 Electrical noise immunity

The ACST310 is a sensitive device ( $I_{GT}$  max. 10 mA) and can be controlled directly through a simple resistor by a logic level circuit, and still provides a high electrical noise immunity. The intrinsic immunity of the ACST310 is shown by the specified  $dV/dt$  equal to 1000 V/ $\mu$ s at 125 °C. This immunity level is 5 to 10 times higher than the immunity provided by an equivalent standard technology Triac with the same sensitivity. In other words, the ACST310 with  $I_{GT} = 10$  mA has immunity comparable only for higher gate current device ( $I_{GT}$  higher than 35 mA).

### 3 Package information

- Epoxy meets UL94-V0
- Halogen free molding compound
- Lead-free package
- Recommended torque: 0.4 to 0.6 N·m

In order to meet environmental requirements, ST offers these devices in different grades of ECOPACK® packages, depending on their level of environmental compliance. ECOPACK® specifications, grade definitions and product status are available at: [www.st.com](http://www.st.com). ECOPACK® is an ST trademark.

#### 3.1 TO-220FPAB package information

Figure 19. TO-220FPAB package outline

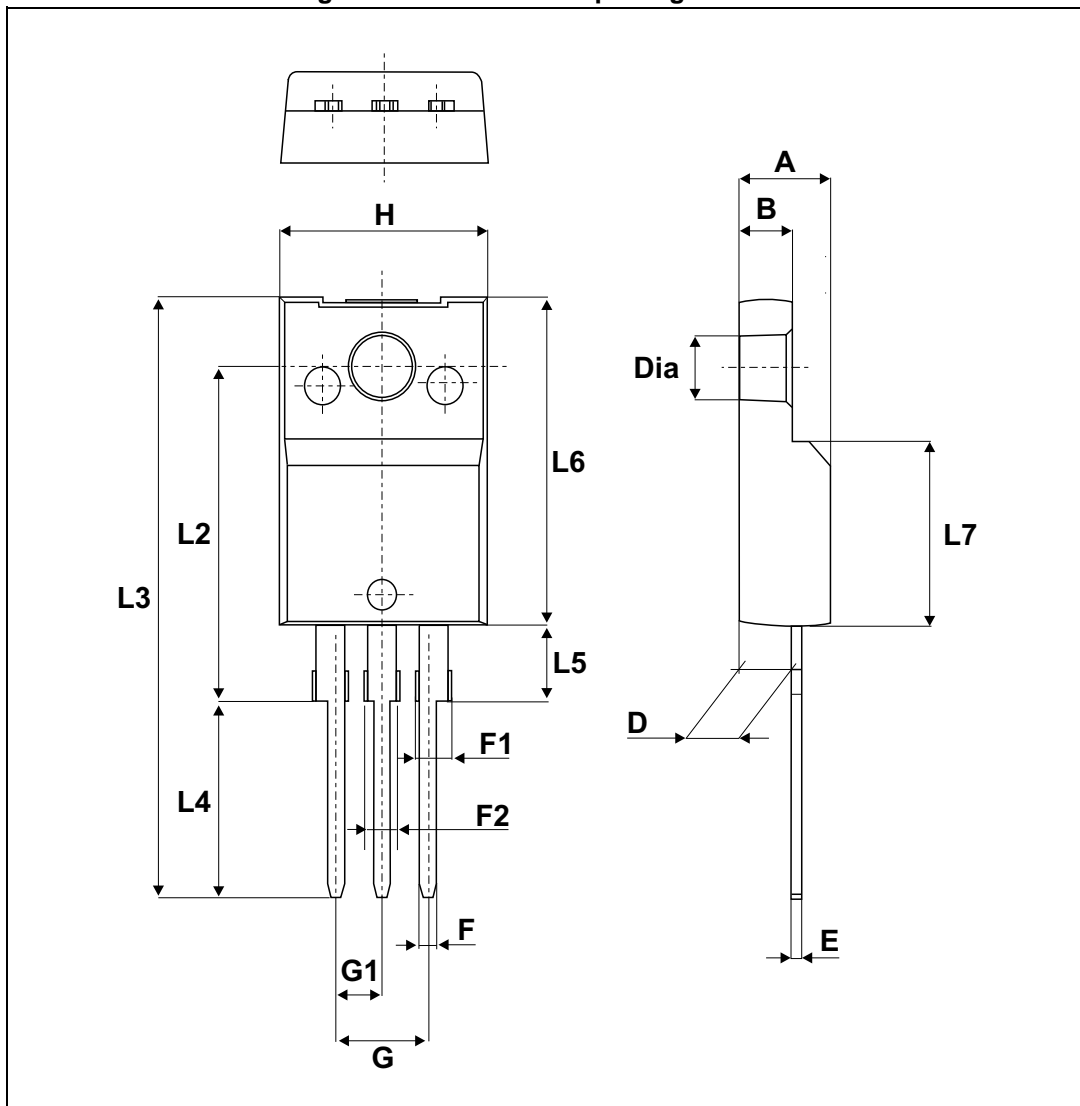

Table 6. TO-220FPAB package mechanical data

Ref.	Dimensions			
	Millimeters		Inches	
	Min.	Max.	Min.	Max.
A	4.4	4.6	0.173	0.181
B	2.5	2.7	0.098	0.106
D	2.5	2.75	0.098	0.108
E	0.45	0.70	0.018	0.027
F	0.75	1	0.030	0.039
F1	1.15	1.70	0.045	0.067
F2	1.15	1.70	0.045	0.067
G	4.95	5.20	0.195	0.205
G1	2.4	2.7	0.094	0.106
H	10	10.4	0.393	0.409
L2	16 Typ.		0.63 Typ.	
L3	28.6	30.6	1.126	1.205
L4	9.8	10.6	0.386	0.417
L5	2.9	3.6	0.114	0.142
L6	15.9	16.4	0.626	0.646
L7	9.00	9.30	0.354	0.366
Dia.	3.00	3.20	0.118	0.126

## 4 Ordering information

Figure 20. Ordering information scheme

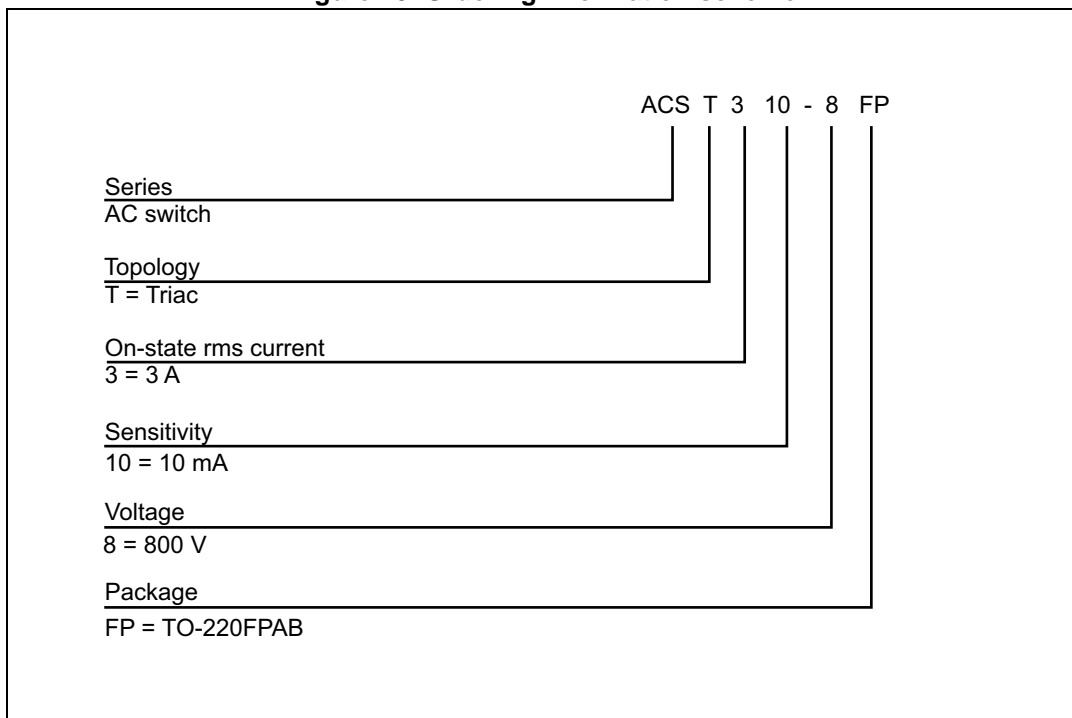

Table 7. Ordering information

Order code	Marking	Package	Weight	Base qty	Packing mode
ACST310-8FP	ACST3108	TO-220FPAB	2.0 g	50	Tube

## 5 Revision history

Table 8. Document revision history

Date	Revision	Changes
23-Apr-2015	1	First issue.

**IMPORTANT NOTICE – PLEASE READ CAREFULLY**

STMicroelectronics NV and its subsidiaries (“ST”) reserve the right to make changes, corrections, enhancements, modifications, and improvements to ST products and/or to this document at any time without notice. Purchasers should obtain the latest relevant information on ST products before placing orders. ST products are sold pursuant to ST’s terms and conditions of sale in place at the time of order acknowledgement.

Purchasers are solely responsible for the choice, selection, and use of ST products and ST assumes no liability for application assistance or the design of Purchasers’ products.

No license, express or implied, to any intellectual property right is granted by ST herein.

Resale of ST products with provisions different from the information set forth herein shall void any warranty granted by ST for such product.

ST and the ST logo are trademarks of ST. All other product or service names are the property of their respective owners.

Information in this document supersedes and replaces information previously supplied in any prior versions of this document.

© 2015 STMicroelectronics – All rights reserved

