

## High voltage ignition coil driver NPN power Darlington transistors

### Features

- Very rugged Bipolar technology
- High operating junction temperature
- Integrated antiparallel collector-emitter diode

### Applications

- High ruggedness electronic ignitions

### Description

The devices are bipolar Darlington transistors manufactured using Multi-Epitaxial Planar technology. They have been properly designed to be used in automotive environment as electronic ignition power actuators.

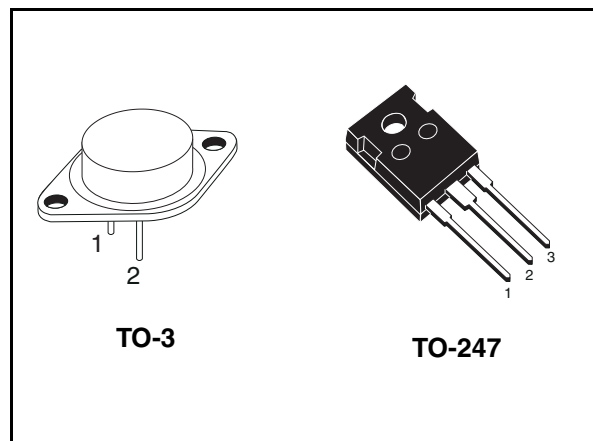

**Figure 1. Internal schematic diagrams**

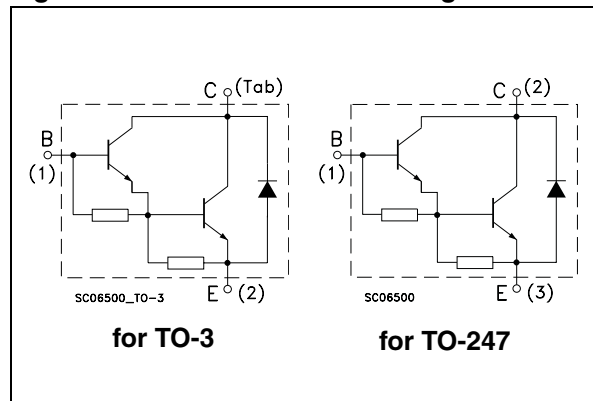

**Table 1. Device summary**

Order codes	Marking	Package	Packaging
BU941	BU941	TO-3	Tray
BU941P	BU941P	TO-247	Tube

# 1 Electrical ratings

**Table 2. Absolute maximum ratings**

Symbol	Parameter	Value		Unit
		BU941	BU941P	
$V_{CES}$	Collector-emitter voltage ( $V_{BE} = 0$ )	500		V
$V_{CEO}$	Collector-emitter voltage ( $I_B = 0$ )	400		V
$V_{EBO}$	Emitter-base voltage ( $I_C = 0$ )	5		V
$I_C$	Collector current	15		A
$I_{CM}$	Collector peak current	30		A
$I_B$	Base current	1		A
$I_{BM}$	Base peak current	5		A
$P_{TOT}$	Total dissipation at $T_c = 25\text{ °C}$	180	155	W
$T_{stg}$	Storage temperature	-65 to 200	-65 to 175	°C
$T_J$	Max. operating junction temperature	200	175	

**Table 3. Thermal data**

Symbol	Parameter	Value	Unit
$R_{thj-case}$	Thermal resistance junction-case max.	0.97	°C/W

## 2 Electrical characteristics

( $T_{\text{case}} = 25\text{ °C}$ ; unless otherwise specified)

**Table 4. Electrical characteristics**

Symbol	Parameter	Test conditions	Min.	Typ.	Max.	Unit
$I_{\text{CES}}$	Collector cut-off current ( $V_{\text{BE}} = 0$ )	$V_{\text{CE}} = 500\text{ V}$ $V_{\text{CE}} = 500\text{ V}$ $T_{\text{C}} = 125\text{ °C}$			100 0.5	$\mu\text{A}$ mA
$I_{\text{CEO}}$	Collector cut-off current ( $I_{\text{B}} = 0$ )	$V_{\text{CE}} = 450\text{ V}$ $V_{\text{CE}} = 450\text{ V}$ $T_{\text{C}} = 125\text{ °C}$			100 0.5	$\mu\text{A}$ mA
$I_{\text{EBO}}$	Emitter cut-off current ( $I_{\text{C}} = 0$ )	$V_{\text{EB}} = 5\text{ V}$			20	mA
$V_{\text{CEO(sus)}}^{(1)}$	Collector-emitter sustaining voltage ( $I_{\text{B}} = 0$ )	$I_{\text{C}} = 10\text{ mA}$ $L = 10\text{ mH}$ $V_{\text{clamp}} = 400\text{ V}$ see <a href="#">Figure 12</a>	400			V
$V_{\text{CE(sat)}}^{(1)}$	Collector-emitter saturation voltage	$I_{\text{C}} = 8\text{ A}$ $I_{\text{B}} = 100\text{ mA}$ $I_{\text{C}} = 10\text{ A}$ $I_{\text{B}} = 250\text{ mA}$ $I_{\text{C}} = 12\text{ A}$ $I_{\text{B}} = 300\text{ mA}$			1.6 1.8 2	V V V
$V_{\text{BE(sat)}}^{(1)}$	Base-emitter saturation voltage	$I_{\text{C}} = 8\text{ A}$ $I_{\text{B}} = 100\text{ mA}$ $I_{\text{C}} = 10\text{ A}$ $I_{\text{B}} = 250\text{ mA}$ $I_{\text{C}} = 12\text{ A}$ $I_{\text{B}} = 300\text{ mA}$			2.2 2.5 2.7	V V V
$h_{\text{FE}}^{(1)}$	DC current gain	$I_{\text{C}} = 5\text{ A}$ $V_{\text{CE}} = 10\text{ V}$	300			
$V_{\text{F}}$	Diode forward voltage	$I_{\text{F}} = 10\text{ A}$			2.5	V
	Functional test	$V_{\text{CC}} = 24\text{ V}$ $L = 7\text{ mH}$ $V_{\text{clamp}} = 400\text{ V}$ see <a href="#">Figure 9</a>	10			A
$t_{\text{s}}$ $t_{\text{f}}$	Inductive Load Storage time Fall time	$I_{\text{C}} = 7\text{ A}$ $V_{\text{clamp}} = 300\text{ V}$ $I_{\text{B}} = 70\text{ mA}$ $L = 7\text{ mH}$ $V_{\text{BE}} = 0$ $R_{\text{BE}} = 47\text{ }\Omega$ $V_{\text{CC}} = 12\text{ V}$ see <a href="#">Figure 11</a>		15 0.5		$\mu\text{s}$ $\mu\text{s}$

1. Pulsed duration = 300  $\mu\text{s}$ , duty cycle  $\leq 1.5\%$

## 4 Package mechanical data

In order to meet environmental requirements, ST offers these devices in ECOPACK® packages. These packages have a lead-free second level interconnect . The category of second level interconnect is marked on the package and on the inner box label, in compliance with JEDEC Standard JESD97. The maximum ratings related to soldering conditions are also marked on the inner box label. ECOPACK is an ST trademark.

**TO-3 mechanical data**

DIM.	mm.		
	min.	typ	max.
A	11.00		13.10
B	0.97		1.15
C	1.50		1.65
D	8.32		8.92
E	19.00		20.00
G	10.70		11.10
N	16.50		17.20
P	25.00		26.00
R	4.00		4.09
U	38.50		39.30
V	30.00		30.30

