



## BUL38D

# HIGH VOLTAGE FAST-SWITCHING NPN POWER TRANSISTOR

- STMicroelectronics PREFERRED SALESTYPE
- HIGH VOLTAGE CAPABILITY
- LOW SPREAD OF DYNAMIC PARAMETERS
- MINIMUM LOT-TO-LOT SPREAD FOR RELIABLE OPERATION
- LOW BASE-DRIVE REQUIREMENTS
- VERY HIGH SWITCHING SPEED
- FULLY CHARACTERISED AT 125°C
- HIGH RUGGEDNESS
- INTEGRATED ANTIPARALLEL COLLECTOR-EMITTER DIODE

### APPLICATIONS

- ELECTRONIC TRANSFORMERS FOR HALOGEN LAMPS
- SWITCH MODE POWER SUPPLIES

### DESCRIPTION

The BUL38D is manufactured using high voltage Multi Epitaxial Planar technology for high switching speeds and high voltage withstand capability.

The BUL series is designed for use in lighting applications and low cost switch-mode power supplies.

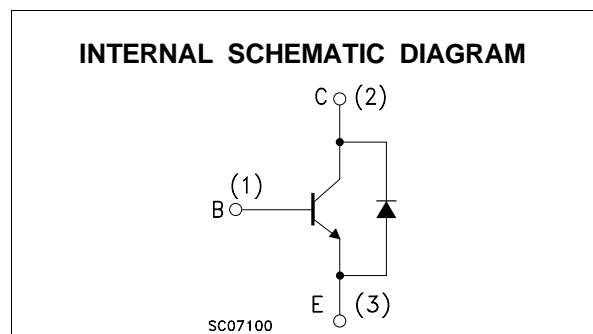
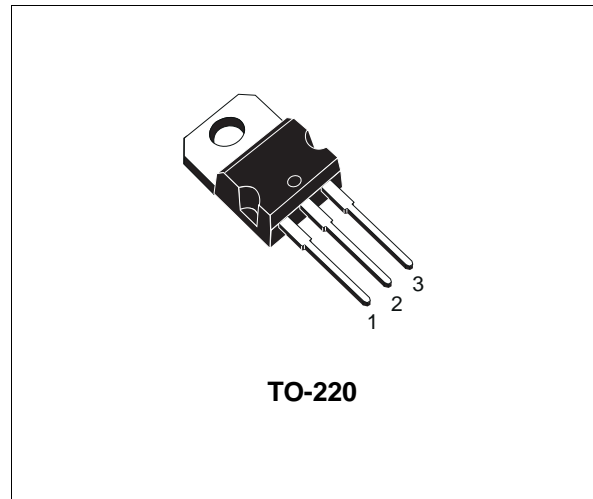

### ABSOLUTE MAXIMUM RATINGS

Symbol	Parameter	Value	Unit
$V_{CES}$	Collector-Emitter Voltage ( $V_{BE} = 0$ )	800	V
$V_{CEO}$	Collector-Emitter Voltage ( $I_B = 0$ )	450	V
$V_{EBO}$	Emitter-Base Voltage ( $I_C = 0$ )	9	V
$I_C$	Collector Current	5	A
$I_{CM}$	Collector Peak Current ( $t_p < 5$ ms)	10	A
$I_B$	Base Current	2	A
$I_{BM}$	Base Peak Current ( $t_p < 5$ ms)	4	A
$P_{tot}$	Total Dissipation at $T_c = 25$ °C	80	W
$T_{stg}$	Storage Temperature	-65 to 150	°C
$T_j$	Max. Operating Junction Temperature	150	°C

## BUL38D

### THERMAL DATA

R <sub>thj-case</sub>	Thermal Resistance Junction-Case	Max	1.56	°C/W
R <sub>thj-amb</sub>	Thermal Resistance Junction-Ambient	Max	62.5	°C/W

### ELECTRICAL CHARACTERISTICS (T<sub>case</sub> = 25 °C unless otherwise specified)

Symbol	Parameter	Test Conditions	Min.	Typ.	Max.	Unit
I <sub>CES</sub>	Collector Cut-off Current (V <sub>BE</sub> = 0)	V <sub>CE</sub> = 800 V			100	μA
		V <sub>CE</sub> = 800 V    T <sub>c</sub> = 125 °C			500	μA
I <sub>CEO</sub>	Collector Cut-off Current (I <sub>B</sub> = 0)	V <sub>CE</sub> = 450 V			250	μA
V <sub>CEO(sus)*</sub>	Collector-Emitter Sustaining Voltage (I <sub>B</sub> = 0)	I <sub>C</sub> = 100 mA    L = 25 mH	450			V
V <sub>EBO</sub>	Emitter-Base Voltage (I <sub>C</sub> = 0)	I <sub>E</sub> = 10 mA	9			V
V <sub>CE(sat)*</sub>	Collector-Emitter Saturation Voltage	I <sub>C</sub> = 1 A    I <sub>B</sub> = 0.2 A			0.5	V
		I <sub>C</sub> = 2 A    I <sub>B</sub> = 0.4 A			0.7	V
		I <sub>C</sub> = 3 A    I <sub>B</sub> = 0.75 A			1.1	V
V <sub>BE(sat)*</sub>	Base-Emitter Saturation Voltage	I <sub>C</sub> = 1 A    I <sub>B</sub> = 0.2 A			1.1	V
		I <sub>C</sub> = 2 A    I <sub>B</sub> = 0.4 A			1.2	V
h <sub>FE*</sub>	DC Current Gain	I <sub>C</sub> = 10 mA    V <sub>CE</sub> = 5 V	10			
		I <sub>C</sub> = 0.5 A    V <sub>CE</sub> = 5 V			60	
		I <sub>C</sub> = 2 A    V <sub>CE</sub> = 5 V				
		Group A	13		23	
	Group B	22		32		
t <sub>s</sub> t <sub>f</sub>	RESISTIVE LOAD	I <sub>C</sub> = 2.5 A    V <sub>CC</sub> = 150 V I <sub>B1</sub> = -I <sub>B2</sub> = 0.5 A    t <sub>p</sub> = 30 μs (see figure 2)	1.0		2.2	μs
	Storage Time					
t <sub>s</sub> t <sub>f</sub>	INDUCTIVE LOAD	I <sub>C</sub> = 2 A    I <sub>B1</sub> = 0.4 A V <sub>BE(off)</sub> = -5 V    R <sub>BB</sub> = 0 Ω V <sub>CL</sub> = 250 V    L = 200 μH (see figure 1)			1.8	μs
	Storage Time					
t <sub>s</sub> t <sub>f</sub>	INDUCTIVE LOAD	I <sub>C</sub> = 2 A    I <sub>B1</sub> = 0.4 A V <sub>BE(off)</sub> = -5 V    R <sub>BB</sub> = 0 Ω V <sub>CL</sub> = 250 V    L = 200 μH T <sub>c</sub> = 125 °C    (see figure 1)			100	ns
	Storage Time					
V <sub>f</sub>	Diode Forward Voltage	I <sub>C</sub> = 2 A			1.5	V

\* Pulsed: Pulse duration = 300 μs, duty cycle 1.5 %.

The product is pre-selected in DC current gain (Group A and Group B). STMicroelectronics reserves the right to ship either groups according to production availability. Please contact your nearest STMicroelectronics sales office for delivery details.

**TO-220 MECHANICAL DATA**

DIM.	mm			inch		
	MIN.	TYP.	MAX.	MIN.	TYP.	MAX.
A	4.40		4.60	0.173		0.181
C	1.23		1.32	0.048		0.052
D	2.40		2.72	0.094		0.107
E	0.49		0.70	0.019		0.027
F	0.61		0.88	0.024		0.034
F1	1.14		1.70	0.044		0.067
F2	1.14		1.70	0.044		0.067
G	4.95		5.15	0.194		0.202
G1	2.40		2.70	0.094		0.106
H2	10.00		10.40	0.394		0.409
L2		16.40			0.645	
L4	13.00		14.00	0.511		0.551
L5	2.65		2.95	0.104		0.116
L6	15.25		15.75	0.600		0.620
L7	6.20		6.60	0.244		0.260
L9	3.50		3.93	0.137		0.154
M		2.60			0.102	
DIA.	3.75		3.85	0.147		0.151

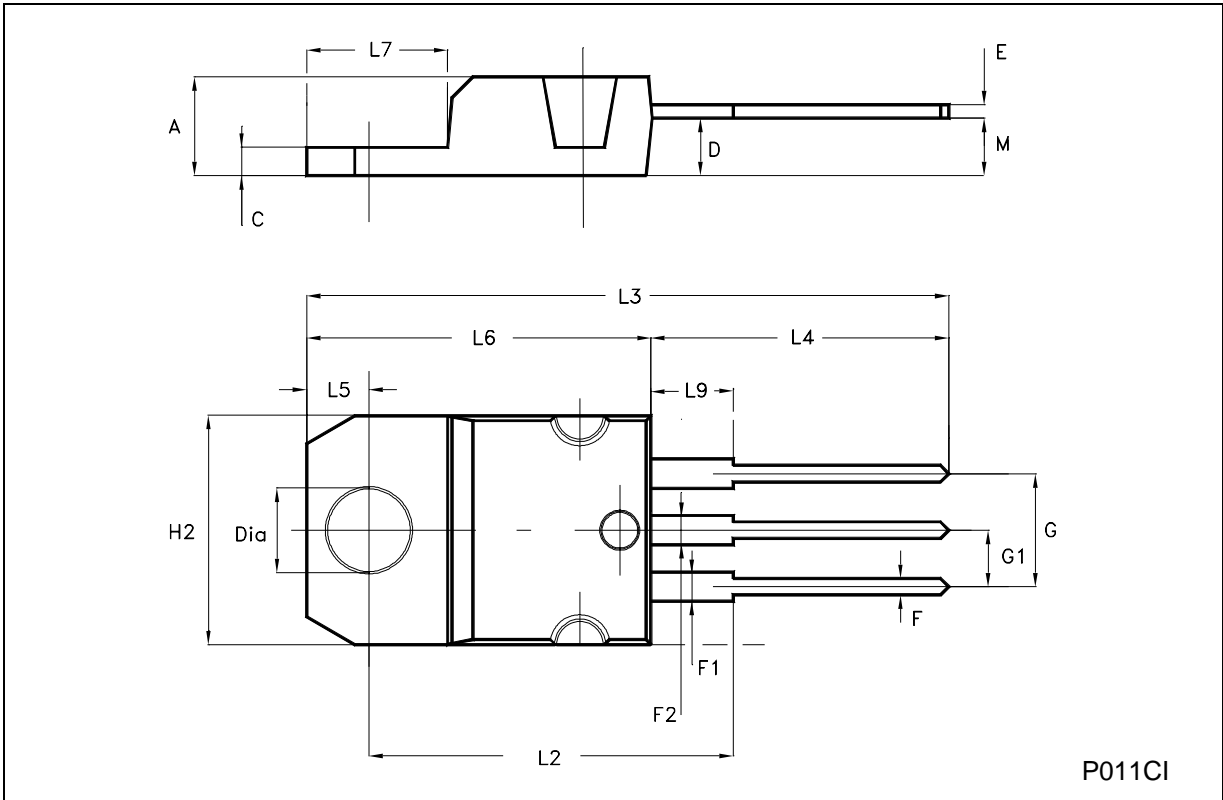

P011CI

