



# D45H5 D45H8 \ D45H11

## PNP SILICON POWER TRANSISTORS

- STMicroelectronics PREFERRED SALESTYPES
- LOW COLLECTOR-EMITTER SATURATION VOLTAGE
- FAST SWITCHING SPEED

### APPLICATIONS

- GENERAL PURPOSE SWITCHING AND AMPLIFIER

### DESCRIPTION

The D45H5, D45H8 and D45H11 are silicon Multi-Epitaxial Planar PNP transistors mounted in Jedec TO-220 plastic package.

They are intended for various switching and general purpose applications.

D45H8, D45H11 are complementary with D44H8, D44H11.

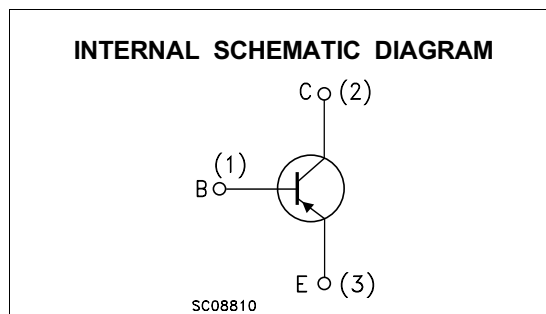
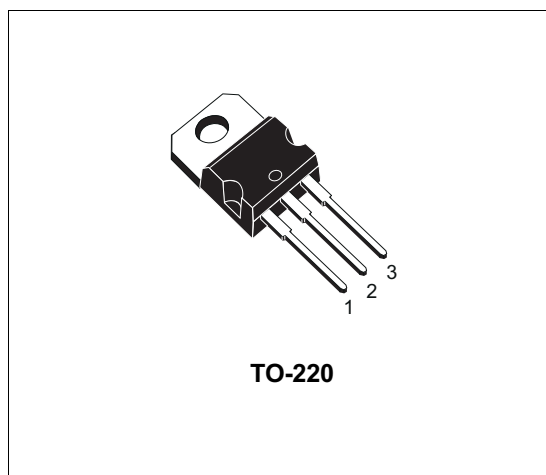

### ABSOLUTE MAXIMUM RATINGS

Symbol	Parameter	Value			Unit
		D45H5	D45H8	D45H11	
$V_{CEO}$	Collector-Emitter Voltage ( $I_B = 0$ )	-45	-60	-80	V
$V_{EBO}$	Emitter-Base Voltage ( $I_C = 0$ )	-5			V
$I_C$	Collector Current	-10			A
$I_{CM}$	Collector Peak Current	-20			A
$I_B$	Base Current	-5			A
$P_{tot}$	Total Dissipation at $T_c \leq 25^\circ\text{C}$	50			W
$T_{stg}$	Storage Temperature	-65 to 150			$^\circ\text{C}$
$T_j$	Max. Operating Junction Temperature	150			$^\circ\text{C}$

# D45H5/D45H8/D45H11

## THERMAL DATA

$R_{thj-case}$	Thermal Resistance Junction-case	Max	2.5	$^{\circ}C/W$
----------------	----------------------------------	-----	-----	---------------

## ELECTRICAL CHARACTERISTICS ( $T_{case} = 25^{\circ}C$ unless otherwise specified)

Symbol	Parameter	Test Conditions	Min.	Typ.	Max.	Unit
$I_{CBO}$	Collector Cut-off Current ( $I_E = 0$ )	$V_{CB} = \text{rated } V_{CEO}$			-10	$\mu A$
$I_{EBO}$	Emitter Cut-off Current ( $I_C = 0$ )	$V_{EB} = -5V$			-100	$\mu A$
$V_{CEO(sus)*}$	Collector-Emitter Sustaining Voltage ( $I_B = 0$ )	$I_C = -100 \text{ mA}$ for <b>D45H5</b> for <b>D45H8</b> for <b>D45H11</b>	-45 -60 -80			V V
$V_{CE(sat)*}$	Collector-Emitter Saturation Voltage	$I_C = -8 \text{ A}$ $I_B = -0.4 \text{ A}$ $I_C = -8 \text{ A}$ $I_B = -0.8 \text{ A}$			-1 -1	V V
$V_{BE(sat)*}$	Base-Emitter Saturation Voltage	$I_C = -8 \text{ A}$ $I_B = -0.8 \text{ A}$			-1.5	V
$h_{FE*}$	DC Current Gain	$I_C = -2 \text{ A}$ $V_{CE} = -1 \text{ V}$ $I_C = -4 \text{ A}$ $V_{CE} = -1 \text{ V}$	60 40	120 70		

\* Pulsed: Pulse duration = 300  $\mu s$ , duty cycle  $\leq 2\%$

## Safe Operating Area

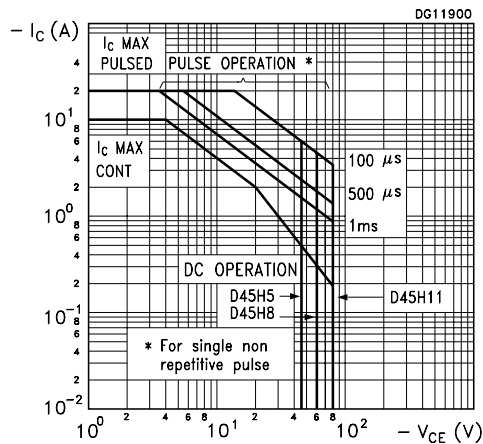

## Derating Curves

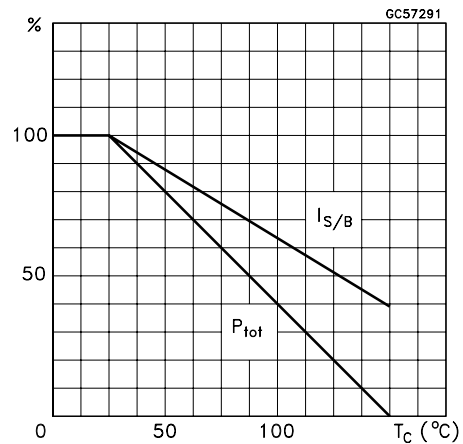

DC Current Gain

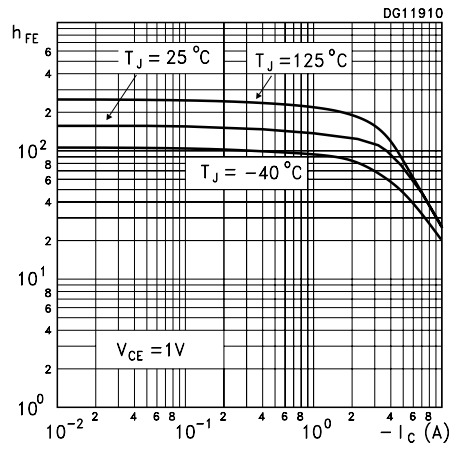

DC Current Gain

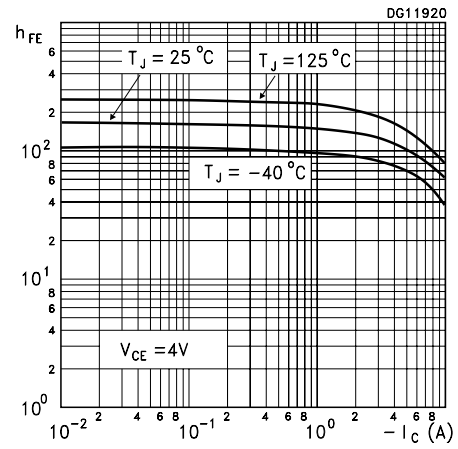

Collector-Emitter Saturation Voltage

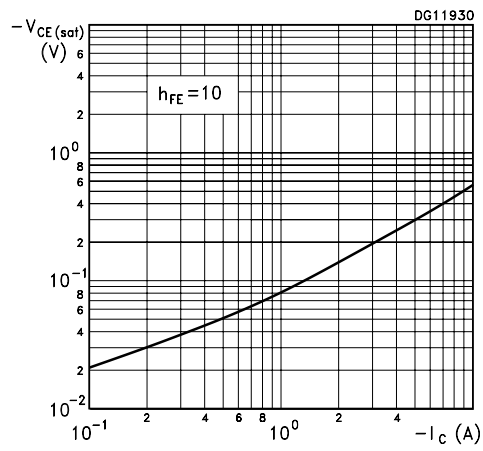

Base-Emitter Saturation Voltage

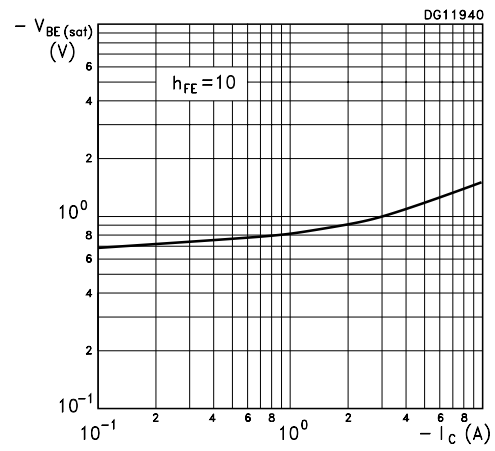

**TO-220 MECHANICAL DATA**

DIM.	mm			inch		
	MIN.	TYP.	MAX.	MIN.	TYP.	MAX.
A	4.40		4.60	0.173		0.181
C	1.23		1.32	0.048		0.052
D	2.40		2.72	0.094		0.107
E	0.49		0.70	0.019		0.027
F	0.61		0.88	0.024		0.034
F1	1.14		1.70	0.044		0.067
F2	1.14		1.70	0.044		0.067
G	4.95		5.15	0.194		0.202
G1	2.40		2.70	0.094		0.106
H2	10.00		10.40	0.394		0.409
L2		16.40			0.645	
L4	13.00		14.00	0.511		0.551
L5	2.65		2.95	0.104		0.116
L6	15.25		15.75	0.600		0.620
L7	6.20		6.60	0.244		0.260
L9	3.50		3.93	0.137		0.154
M		2.60			0.102	
DIA.	3.75		3.85	0.147		0.151

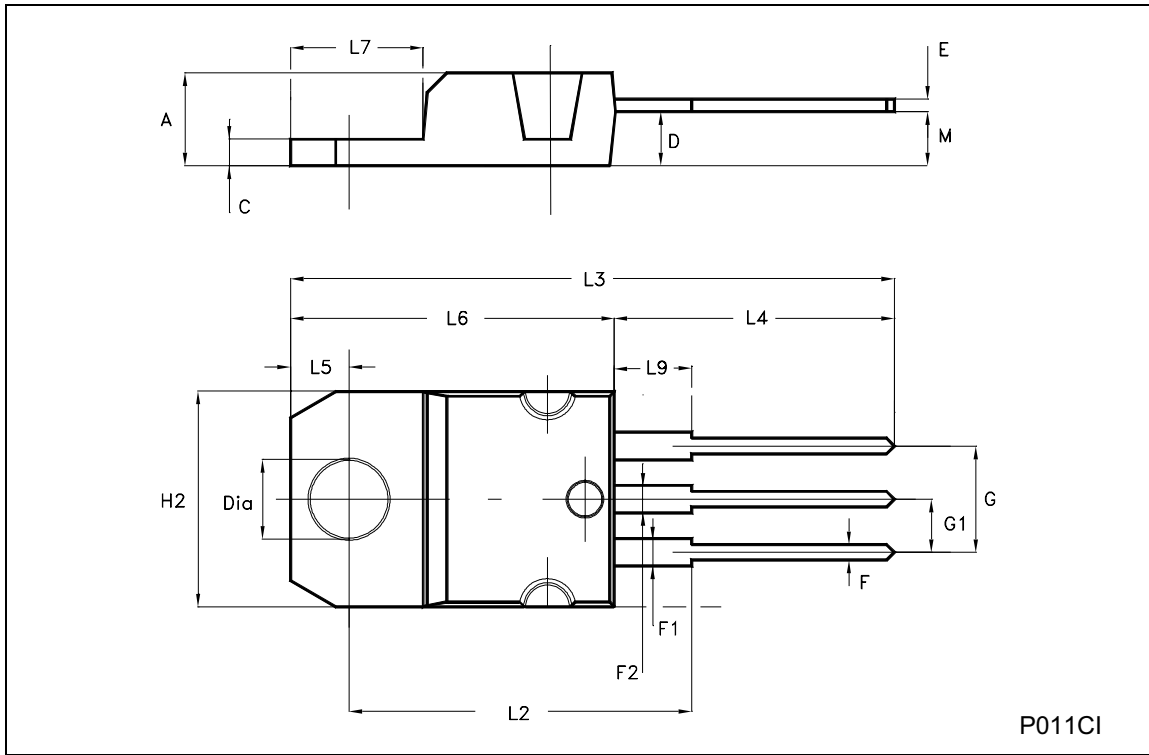

Information furnished is believed to be accurate and reliable. However, STMicroelectronics assumes no responsibility for the consequences of use of such information nor for any infringement of patents or other rights of third parties which may result from its use. No license is granted by implication or otherwise under any patent or patent rights of STMicroelectronics. Specification mentioned in this publication are subject to change without notice. This publication supersedes and replaces all information previously supplied. STMicroelectronics products are not authorized for use as critical components in life support devices or systems without express written approval of STMicroelectronics.

The ST logo is a trademark of STMicroelectronics

© 2003 STMicroelectronics – Printed in Italy – All Rights Reserved  
STMicroelectronics GROUP OF COMPANIES

Australia - Brazil - Canada - China - Finland - France - Germany - Hong Kong - India - Israel - Italy - Japan - Malaysia - Malta - Morocco - Singapore - Spain - Sweden - Switzerland - United Kingdom - United States.

<http://www.st.com>

