



# 1 Characteristics

**Table 1. Absolute ratings (limiting values)**

Symbol	Parameter and test conditions	Value	Unit
$T_j$	Maximum junction temperature	125	°C
$T_{op}$	Operating temperature range	- 40 to + 85	°C
$T_{stg}$	Storage temperature range	- 55 to + 150	°C

**Table 2. Electrical characteristics (Tamb = 25° C)**

Symbol	Parameter	
$V_{BR}$	Breakdown voltage	
$I_{RM}$	Leakage current @ $V_{RM}$	
$V_{RM}$	Stand-off voltage	
$C_{line}$	Input capacitance per line	

Symbol	Test conditions	Tolerance	Min.	Typ.	Max.	Unit
$V_{BR}$	$I_R = 1 \text{ mA}$		6		9	V
$I_{RM}$	$V_{RM} = 5 \text{ V per line}$				1	$\mu\text{A}$
$R_1, R_2$	$I = 10 \text{ mA}$	$\pm 5\%$		33		$\Omega$
$R_3$	$I = 1 \text{ mA}$	$\pm 5\%$		1.5		k $\Omega$
$C_{line}$	@ 0 V			30		pF
Matching	Serial resistance matching			1		%

**Figure 1. S21 (dB) attenuation measurement** **Figure 2. Analog crosstalk measurements**

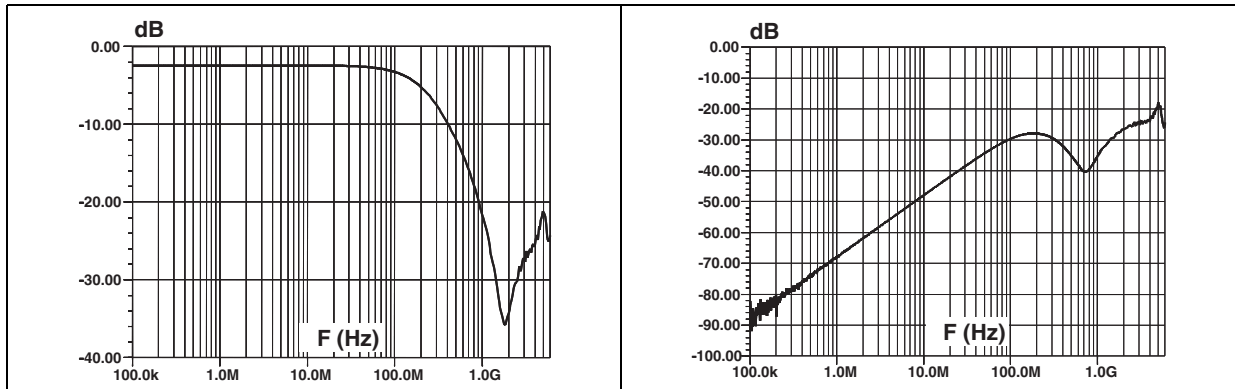

**Figure 3. ESD response to IEC 61000-4-2 (+15 kV air discharge) on one input (Vin) and on one output (Vout)**

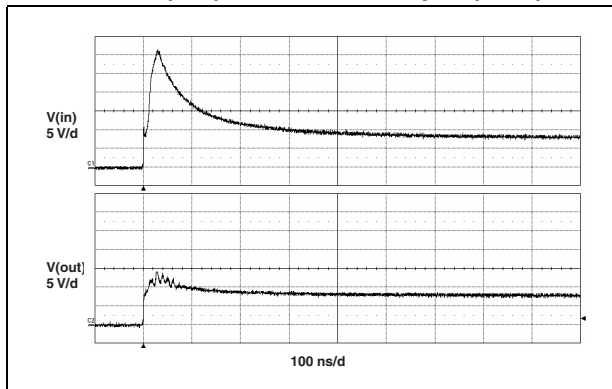

**Figure 4. ESD response to IEC 61000-4-2 (-15 kV air discharge) on one input (Vin) and on one output (Vout)**

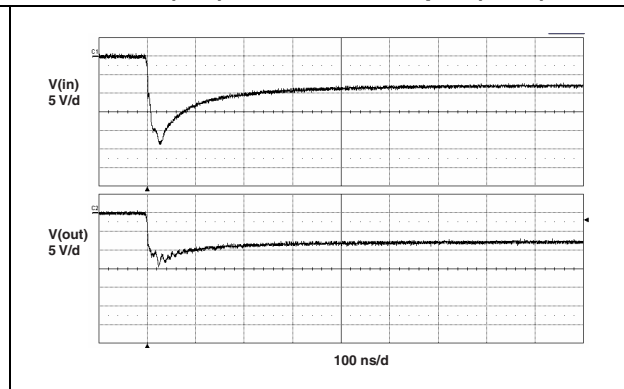

**Figure 5. Junction capacitance versus reverse voltage applied**

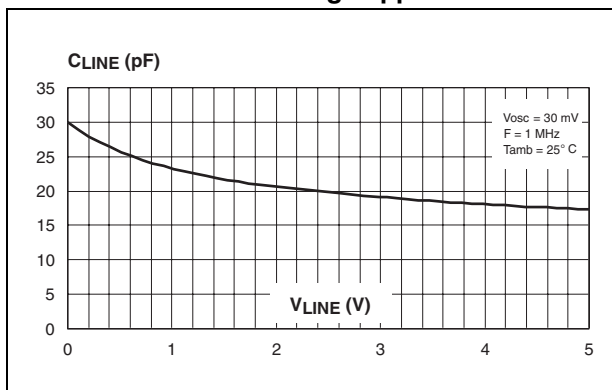

Figure 6. Aplac model device structure

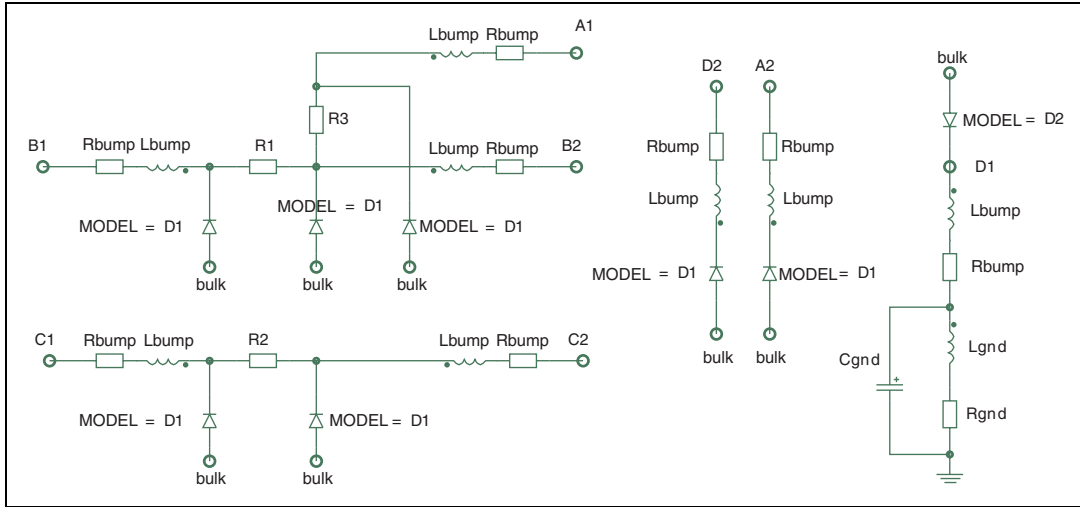
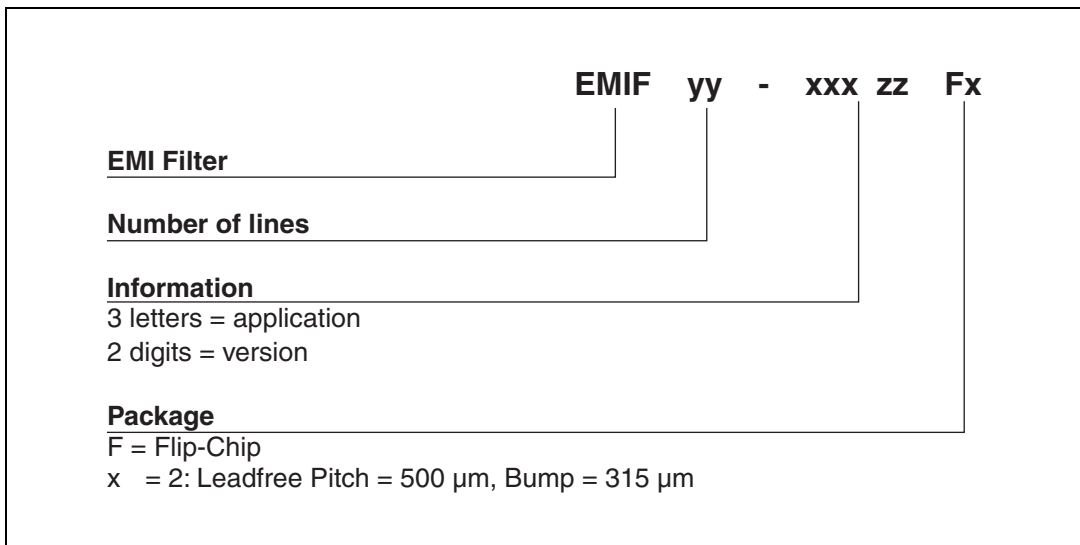

Figure 7. Aplac model parameters

<p>                     aplacvar R1 33                      aplacvar R2 33                      aplacvar R3 1.5k                      aplacvar Cz_D1 15pF                      aplacvar Rs_D1 1                      aplacvar Cz_D2 300pF                      aplacvar Rs_D2 0.3                      aplacvar Lgnd 100pH                      aplacvar Rgnd 100m                      aplacvar Cgnd 0.4pF                      aplacvar Lbump 50pH                      aplacvar Rbump 20m                 </p>	<p> <u>Diode D1</u>                      BV=7                      IBV=1m                      CJO=Cz_d1                      M=0.3333                      RS=Rs_d1                      VJ=0.6                      TT=100n                 </p>	<p> <u>Diode D2</u>                      BV=7                      IBV=1m                      CJO=Cz_d2                      M=0.3333                      RS=Rs_d2                      VJ=0.6                      TT=100n                 </p>
---	--	--

## 2 Ordering information scheme



### 3 Package information

Figure 8. Flip-Chip package dimensions

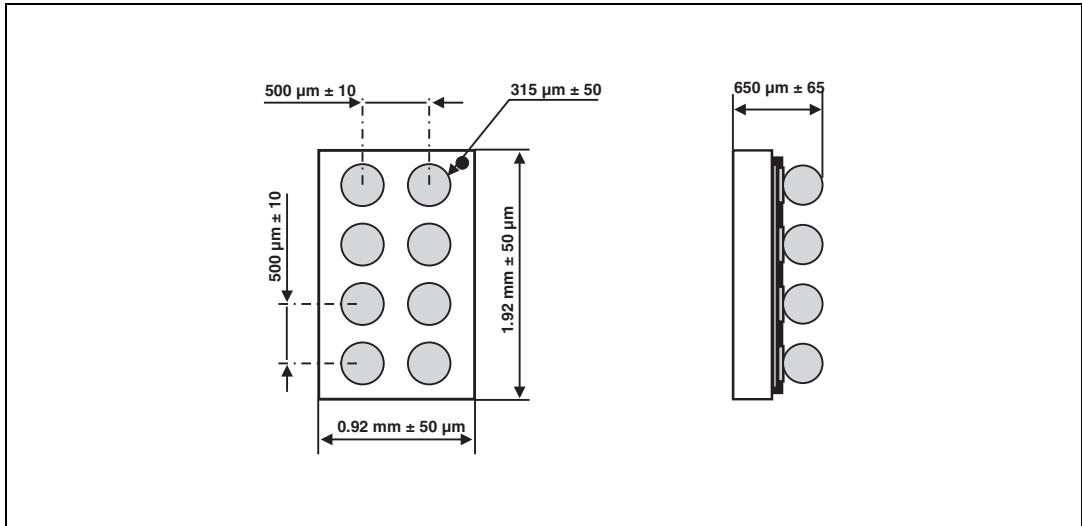

Figure 9. Foot print recommendations      Figure 10. Marking

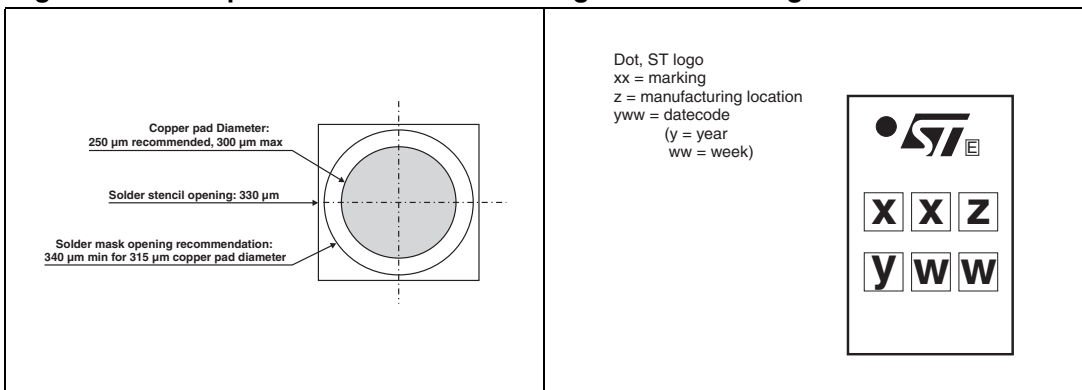
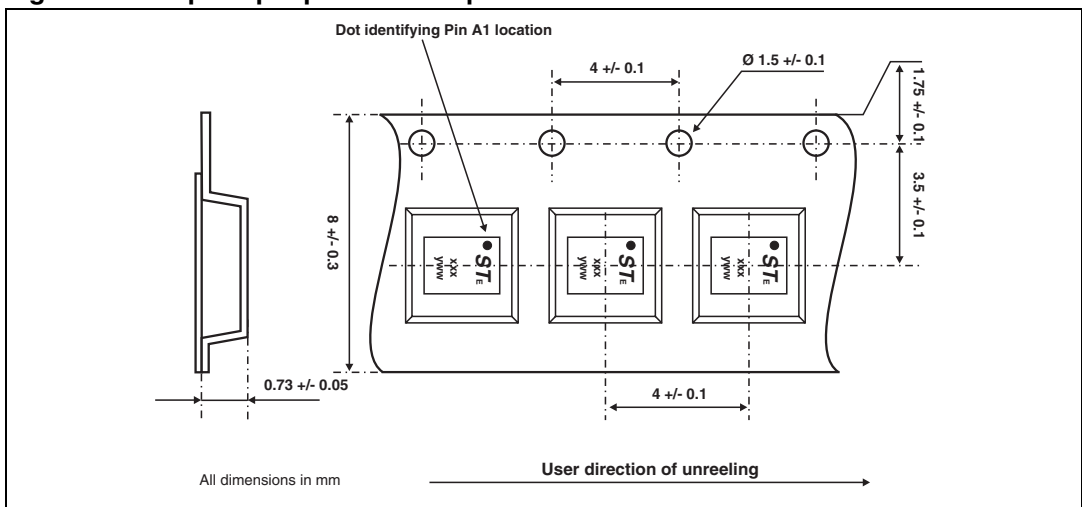

Figure 11. Flip-Chip tape and reel specification



*Note: More packing information is available in the application notes*

*AN1235: "Flip-Chip: Package description and recommendations for use"*

*AN1751: "EMI Filters: Recommendations and measurements"*

In order to meet environmental requirements, ST offers these devices in ECOPACK® packages. These packages have a lead-free second level interconnect. The category of second level interconnect is marked on the package and on the inner box label, in compliance with JEDEC Standard JESD97. The maximum ratings related to soldering conditions are also marked on the inner box label. ECOPACK is an ST trademark. ECOPACK specifications are available at: [www.st.com](http://www.st.com).

## 4 Ordering information

Ordering code	Marking	Package	Weight	Base qty	Delivery mode
EMIF02-USB05F2	GV	Flip-Chip	2.7 mg	5000	Tape and reel 7"

## 5 Revision history

Date	Revision	Changes
14-Mar-2005	1	Initial release.
13-Nov-2006	2	Reformatted to current standards. Modified functional diagram on page 1 to show connections. Updated Aplac model information.

**Please Read Carefully:**

Information in this document is provided solely in connection with ST products. STMicroelectronics NV and its subsidiaries ("ST") reserve the right to make changes, corrections, modifications or improvements, to this document, and the products and services described herein at any time, without notice.

All ST products are sold pursuant to ST's terms and conditions of sale.

Purchasers are solely responsible for the choice, selection and use of the ST products and services described herein, and ST assumes no liability whatsoever relating to the choice, selection or use of the ST products and services described herein.

No license, express or implied, by estoppel or otherwise, to any intellectual property rights is granted under this document. If any part of this document refers to any third party products or services it shall not be deemed a license grant by ST for the use of such third party products or services, or any intellectual property contained therein or considered as a warranty covering the use in any manner whatsoever of such third party products or services or any intellectual property contained therein.

**UNLESS OTHERWISE SET FORTH IN ST'S TERMS AND CONDITIONS OF SALE ST DISCLAIMS ANY EXPRESS OR IMPLIED WARRANTY WITH RESPECT TO THE USE AND/OR SALE OF ST PRODUCTS INCLUDING WITHOUT LIMITATION IMPLIED WARRANTIES OF MERCHANTABILITY, FITNESS FOR A PARTICULAR PURPOSE (AND THEIR EQUIVALENTS UNDER THE LAWS OF ANY JURISDICTION), OR INFRINGEMENT OF ANY PATENT, COPYRIGHT OR OTHER INTELLECTUAL PROPERTY RIGHT.**

**UNLESS EXPRESSLY APPROVED IN WRITING BY AN AUTHORIZED ST REPRESENTATIVE, ST PRODUCTS ARE NOT RECOMMENDED, AUTHORIZED OR WARRANTED FOR USE IN MILITARY, AIR CRAFT, SPACE, LIFE SAVING, OR LIFE SUSTAINING APPLICATIONS, NOR IN PRODUCTS OR SYSTEMS WHERE FAILURE OR MALFUNCTION MAY RESULT IN PERSONAL INJURY, DEATH, OR SEVERE PROPERTY OR ENVIRONMENTAL DAMAGE. ST PRODUCTS WHICH ARE NOT SPECIFIED AS "AUTOMOTIVE GRADE" MAY ONLY BE USED IN AUTOMOTIVE APPLICATIONS AT USER'S OWN RISK.**

Resale of ST products with provisions different from the statements and/or technical features set forth in this document shall immediately void any warranty granted by ST for the ST product or service described herein and shall not create or extend in any manner whatsoever, any liability of ST.

ST and the ST logo are trademarks or registered trademarks of ST in various countries.

Information in this document supersedes and replaces all information previously supplied.

The ST logo is a registered trademark of STMicroelectronics. All other names are the property of their respective owners.

© 2006 STMicroelectronics - All rights reserved

STMicroelectronics group of companies

Australia - Belgium - Brazil - Canada - China - Czech Republic - Finland - France - Germany - Hong Kong - India - Israel - Italy - Japan - Malaysia - Malta - Morocco - Singapore - Spain - Sweden - Switzerland - United Kingdom - United States of America

[www.st.com](http://www.st.com)