

4-line IPAD™, ultra-large bandwidth ESD protection

Features

- 4-line 15 kV ESD protection
- Ultra low line capacitance (0.7 pF typ.)
- Ultra-large bandwidth
 - no influence on signal rise and fall times
 - maximized number of signal harmonics
- Flow-through layout with Type C HDMI™ connector
- Low PCB space occupation - 1.76 mm² footprint
- Very low leakage current: 0.1 µA max.
- 0.4 mm pitch WLCSP package to minimize parasitic inductances
- RoHS compliant

Complies with the standards:

- IEC 61000-4-2 Level 4
 - ± 15 kV (air discharge)
 - ± 8 kV (contact discharge)

Applications

- Mobile phones
- HDMI ports at 1.65 Gb/s and up to 3.2 Gb/s
- USB 2.0 ports up to 480 Mb/s (Hi-Speed)
- Video line protection

TM: IPAD is a trademark of STMicroelectronics. HDMI, the HDMI logo and High-Definition Multimedia Interface are trademarks or registered trademarks of HDMI Licensing LLC.

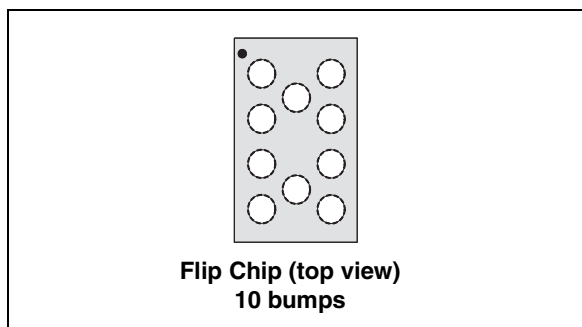
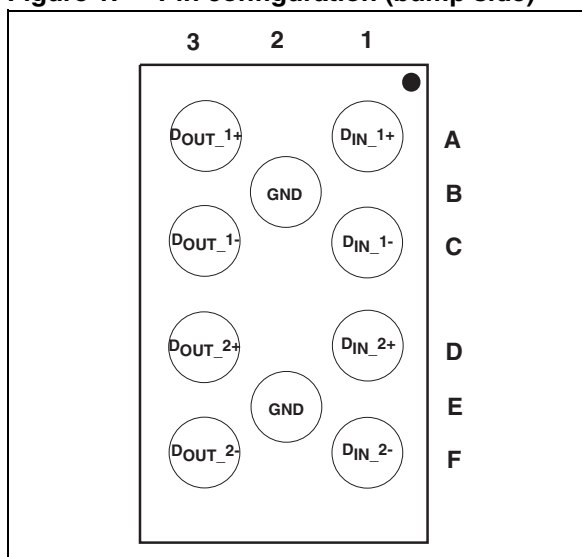

Figure 1. Pin configuration (bump side)



Description

The HDMIULC6-4F3 is a monolithic, application specific discrete device dedicated to ESD protection of the HDMI connection. It also offers the same high level of protection for IEEE 1394a and IEEE 1394b/c, USB 2.0, Ethernet links, and video lines.

Its ultra high cutoff frequency (7 GHz) secures a high level of signal integrity. The device topology provides this integrity without compromising the complete protection of ICs against the most stringent ESD strikes.

1 Characteristics

Figure 2. Internal circuit schematic (top view)

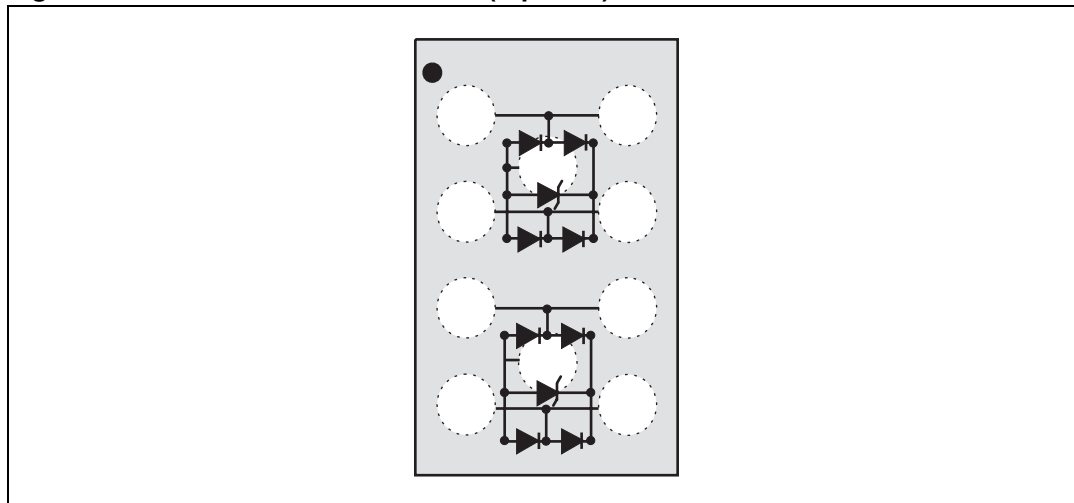

Table 1. Absolute maximum ratings ($T_{amb} = 25\text{ }^{\circ}\text{C}$)

Symbol	Parameter	Value	Unit
V_{PP}	ESD discharge IEC 61000-4-2		
	Air discharge	± 15	kV
	Contact discharge	± 15	
P_{PP}	Peak pulse power dissipation (8/20 μs)	70	W
T_j	Maximum junction temperature	125	$^{\circ}\text{C}$
T_{stg}	Storage temperature range	-55 to + 150	$^{\circ}\text{C}$

Table 2. Electrical characteristics (T_{amb} = 25 °C)

Symbol	Parameter	Test condition	Min.	Typ.	Max.	Unit
V _{BR}	Breakdown voltage between VBUS and GND	I _R = 1 mA	6		9	V
I _{RM}	Leakage current	V _{RM} = 3 V		3	100	nA
C _{I/O-GND} ⁽¹⁾	Capacitance between I/O and GND	V _{line} = 0 V, V _{osc} = 30 mV, F = 1 MHz		1.3		pF
		V _{line} = 0 V, V _{osc} = 30 mV, F = 825 MHz		0.7	0.9	pF
ΔC _{I/O-GND} ⁽¹⁾	Capacitance variation between I/O and GND	V _{line} = 0 V, V _{osc} = 30 mV, F = 1 MHz between two lines of the same lane		0.06		pF
C _{I/O-I/O}	Capacitance between I/O	V _{line} = 0 V, V _{osc} = 30 mV, F = 1 MHz		0.9		pF
		V _{line} = 0 V, V _{osc} = 30 mV, F = 825 MHz		0.55	0.65	pF
ΔC _{I/O-I/O}	Capacitance variation between I/O	V _{line} = 0 V, V _{osc} = 30 mV, F = 1 MHz		0.05		pF
BW	Bandwidth	- 3 dB		7		GHz

1. C_{I/O-GND} values are given per line and relative to one GND.

Figure 3. S21 versus frequency

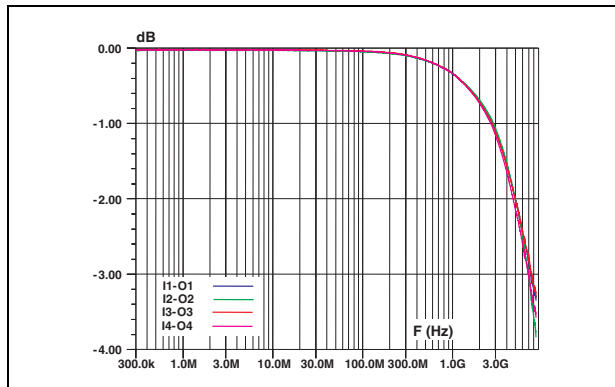

Figure 4. Analog crosstalk measurements

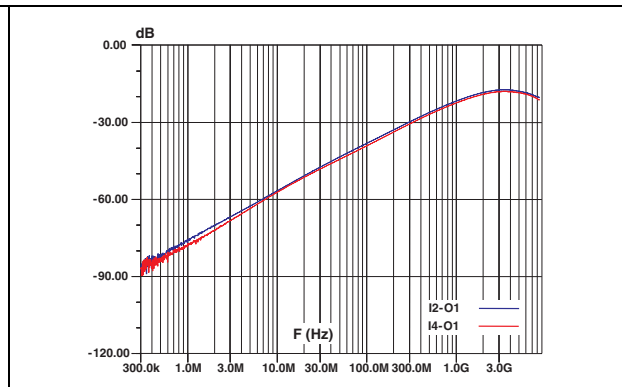

Figure 5. Digital crosstalk measurements I1 - O2

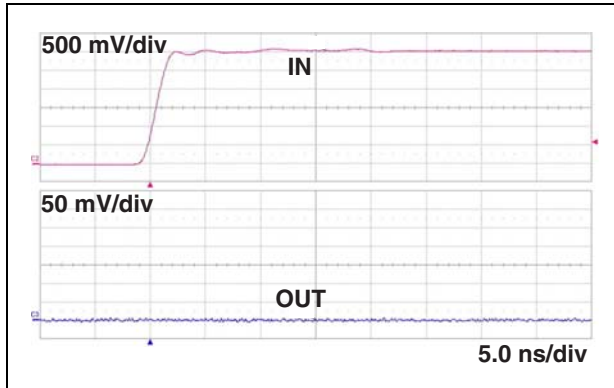

Figure 6. Digital crosstalk measurements I2 - O3

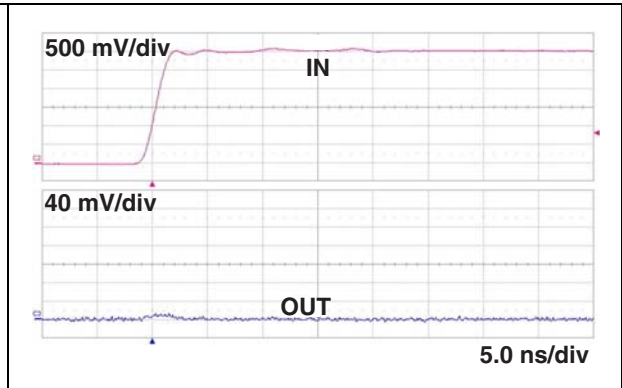

Figure 7. Step response attenuation I1 - O1

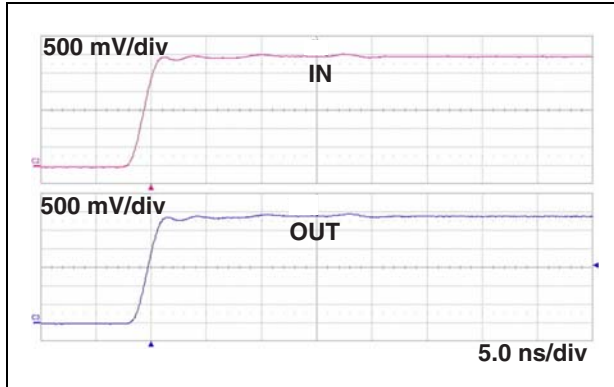

Figure 8. Step response attenuation I2 - O2



Figure 9. ESD response to IEC 61000-4-2 (+8 kV contact discharge) on I1 - O1

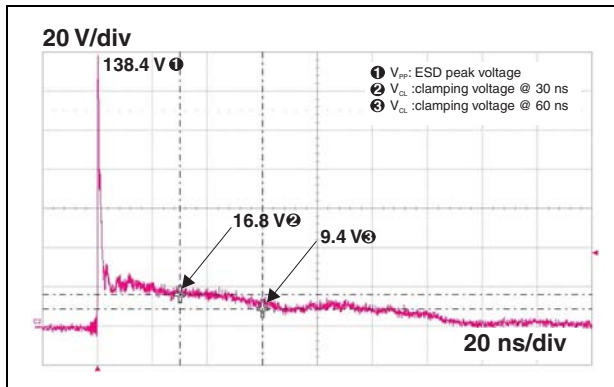

Figure 10. ESD response to IEC 61000-4-2 (-8 kV contact discharge) on I1 - O1

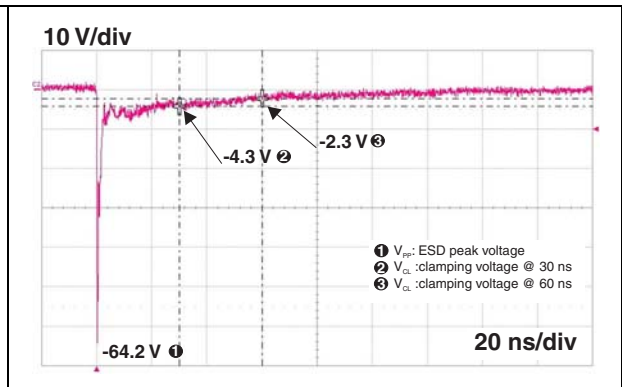

Figure 11. ESD response to IEC 61000-4-2 (+8 kV contact discharge) on I2 - O2

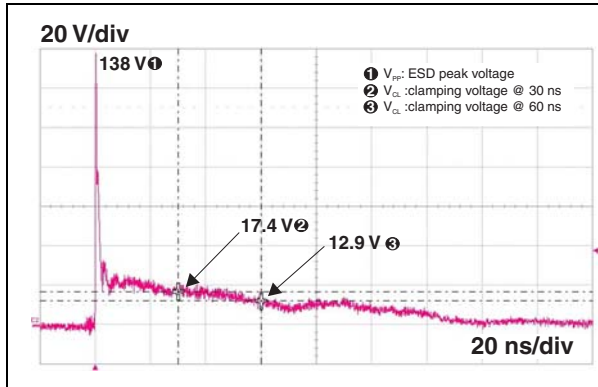

Figure 12. ESD response to IEC 61000-4-2 (-8 kV contact discharge) on I2 - O2

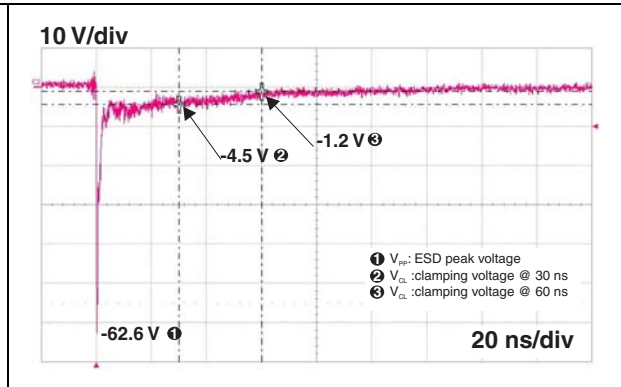

Figure 13. ESD response to IEC 61000-4-2 (+8 kV contact discharge) on I3 - O3

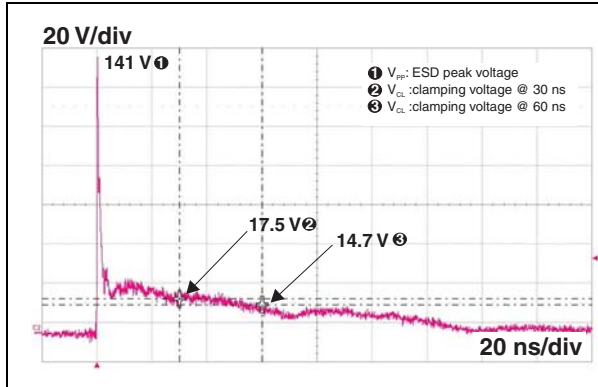

Figure 14. ESD response to IEC 61000-4-2 (-8 kV contact discharge) on I3 - O3

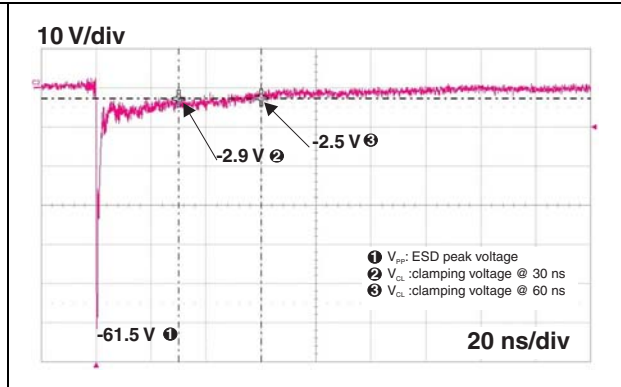
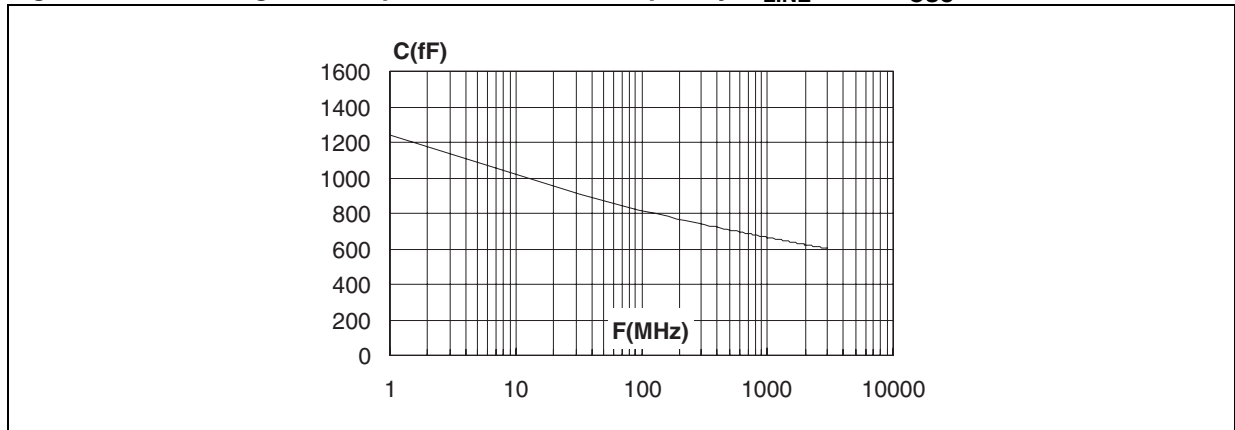
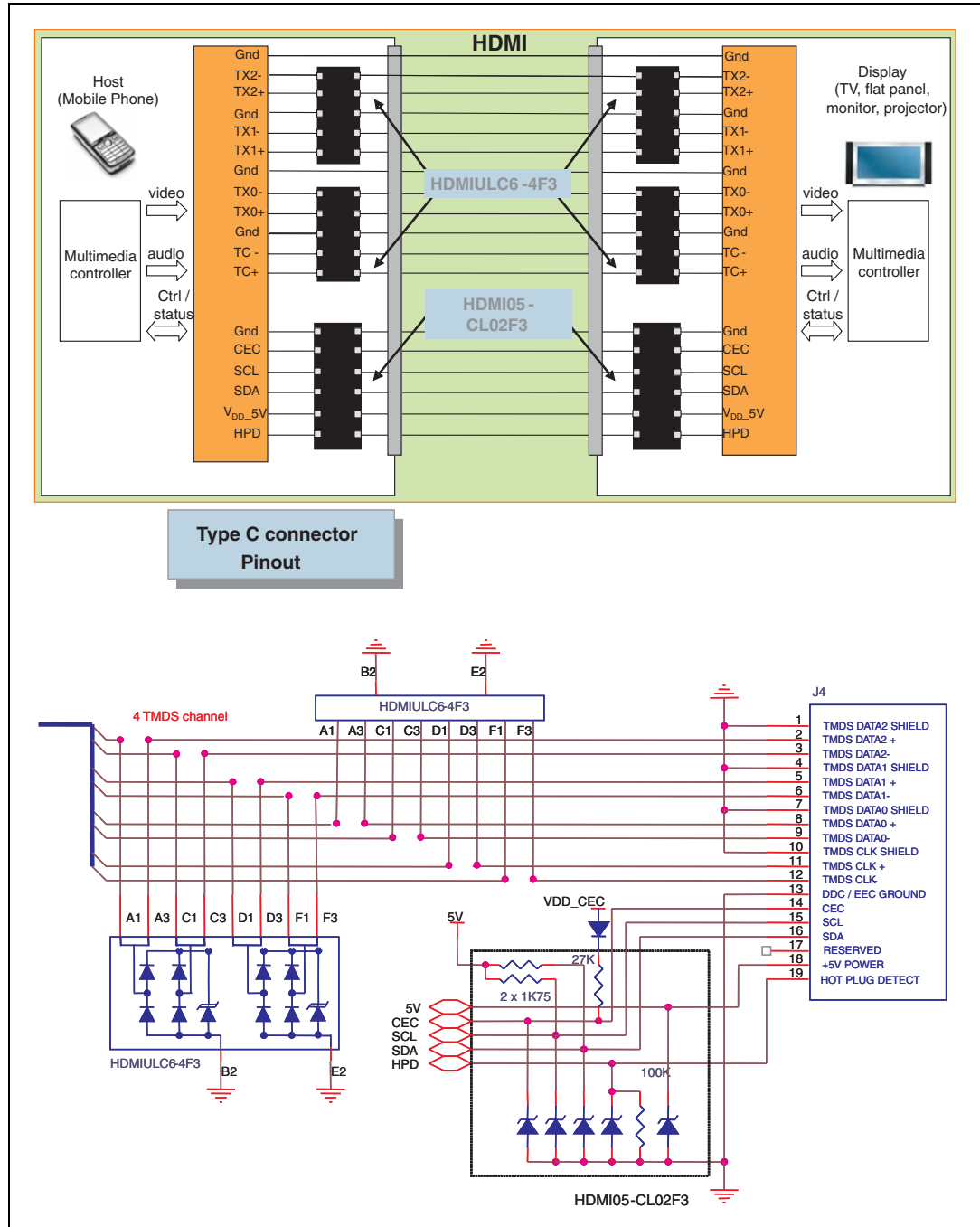

Figure 15. Line to ground capacitance versus frequency, $V_{LINE} = 0 V$, $V_{OSC} = 30 mV$



2 Typical application schematic

Figure 16. Implementation with HDMI type C connector



3 Layout recommendations

Figure 17. Layout recommendations

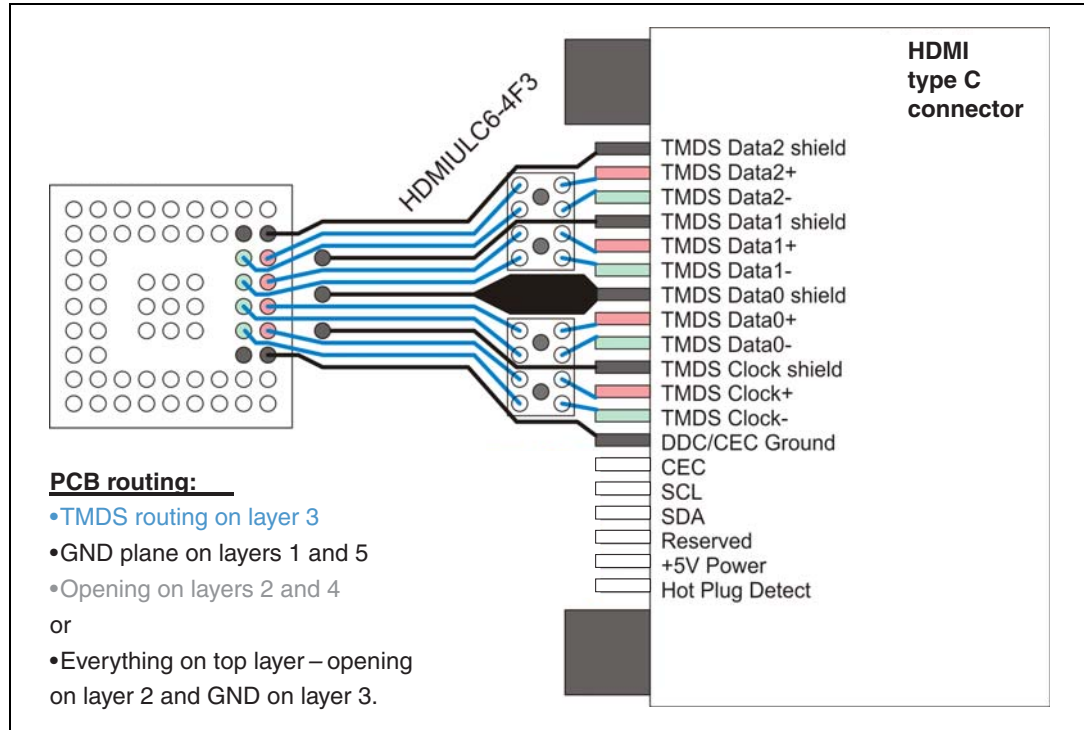

4 Ordering information scheme

Figure 18. Ordering information scheme

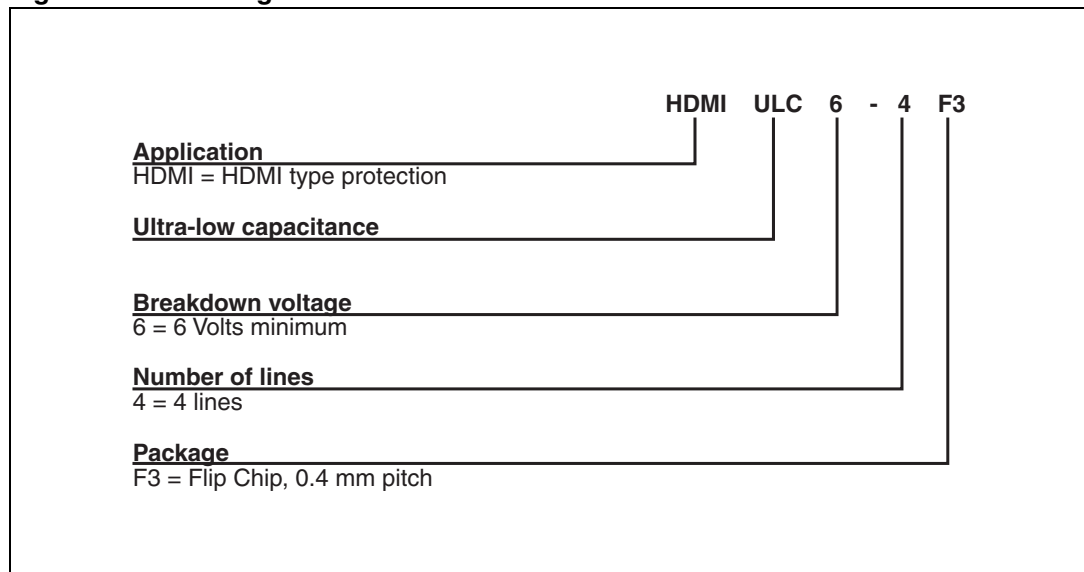

5 Package information

In order to meet environmental requirements, ST offers these devices in different grades of ECOPACK® packages, depending on their level of environmental compliance. ECOPACK® specifications, grade definitions and product status are available at: www.st.com. ECOPACK® is an ST trademark.

Figure 19. Flip Chip dimensions

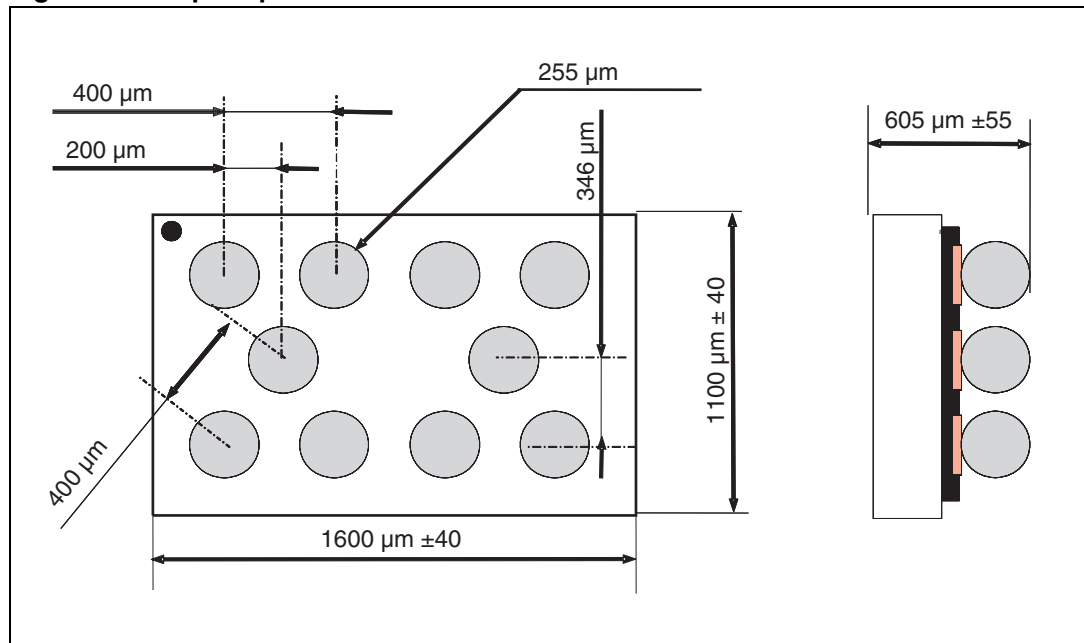

Figure 20. Footprint recommendations

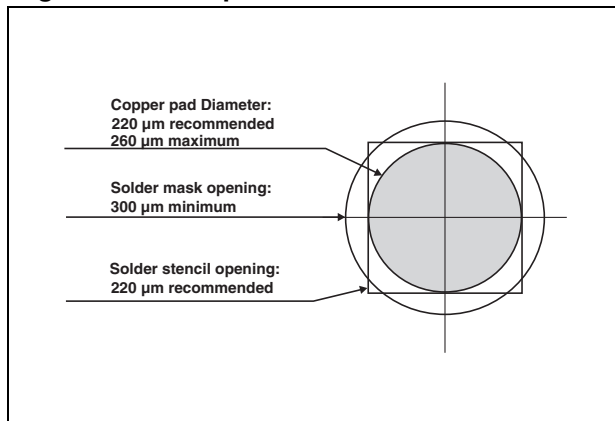

Figure 21. Marking

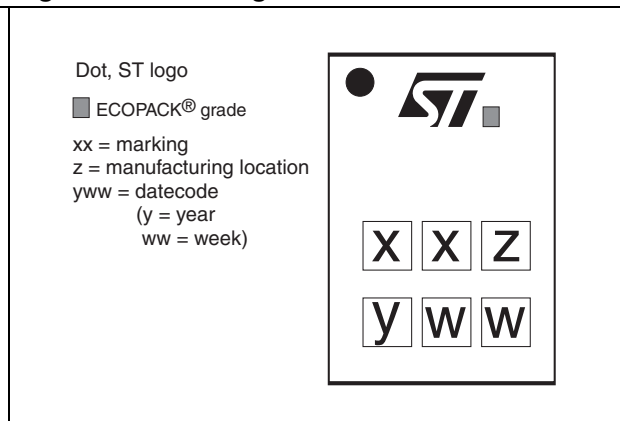
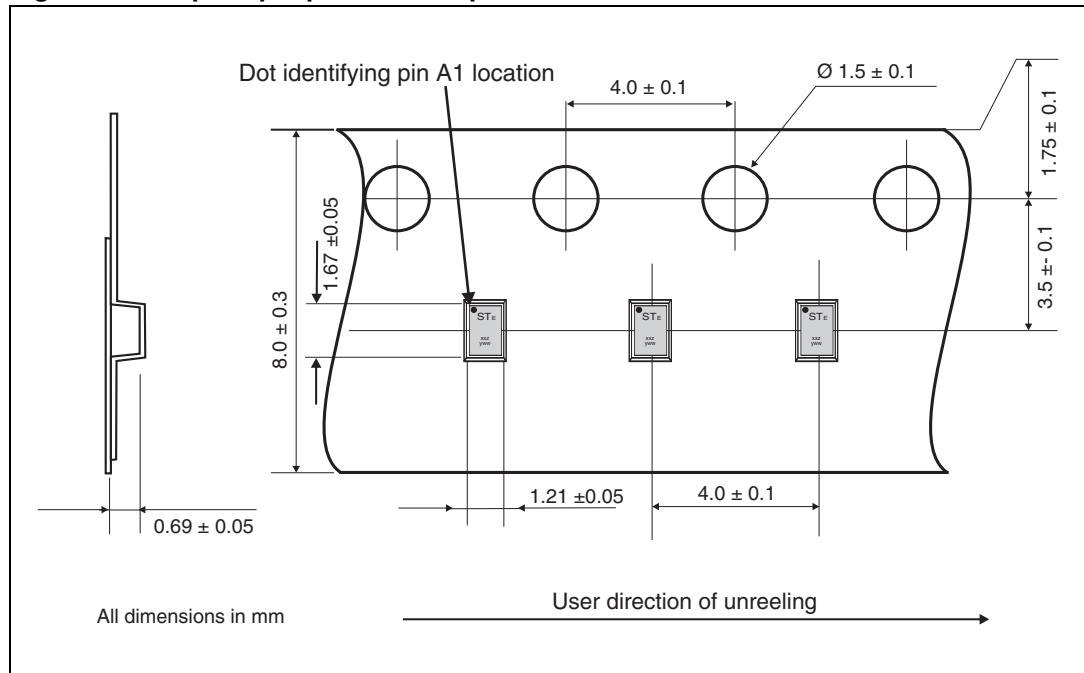

Figure 22. Flip Chip tape and reel specification



6 Ordering information

Table 3. Ordering information

Order code	Marking	Package	Weight	Base qty	Delivery mode
HDMIULC6-4F3	EP	Flip Chip	2.6 mg	5000	Tape and reel (7")

7 Revision history

Table 4. Document revision history

Date	Revision	Changes
24-Mar-2009	1	First issue.
10-Sep-2009	2	Removed "Electrical characteristics, parameters" table. Updated Table 2 and Table 3 . Updated Figure 18 . Added dimension in Figure 19 .

Please Read Carefully:

Information in this document is provided solely in connection with ST products. STMicroelectronics NV and its subsidiaries ("ST") reserve the right to make changes, corrections, modifications or improvements, to this document, and the products and services described herein at any time, without notice.

All ST products are sold pursuant to ST's terms and conditions of sale.

Purchasers are solely responsible for the choice, selection and use of the ST products and services described herein, and ST assumes no liability whatsoever relating to the choice, selection or use of the ST products and services described herein.

No license, express or implied, by estoppel or otherwise, to any intellectual property rights is granted under this document. If any part of this document refers to any third party products or services it shall not be deemed a license grant by ST for the use of such third party products or services, or any intellectual property contained therein or considered as a warranty covering the use in any manner whatsoever of such third party products or services or any intellectual property contained therein.

UNLESS OTHERWISE SET FORTH IN ST'S TERMS AND CONDITIONS OF SALE ST DISCLAIMS ANY EXPRESS OR IMPLIED WARRANTY WITH RESPECT TO THE USE AND/OR SALE OF ST PRODUCTS INCLUDING WITHOUT LIMITATION IMPLIED WARRANTIES OF MERCHANTABILITY, FITNESS FOR A PARTICULAR PURPOSE (AND THEIR EQUIVALENTS UNDER THE LAWS OF ANY JURISDICTION), OR INFRINGEMENT OF ANY PATENT, COPYRIGHT OR OTHER INTELLECTUAL PROPERTY RIGHT.

UNLESS EXPRESSLY APPROVED IN WRITING BY AN AUTHORIZED ST REPRESENTATIVE, ST PRODUCTS ARE NOT RECOMMENDED, AUTHORIZED OR WARRANTED FOR USE IN MILITARY, AIR CRAFT, SPACE, LIFE SAVING, OR LIFE SUSTAINING APPLICATIONS, NOR IN PRODUCTS OR SYSTEMS WHERE FAILURE OR MALFUNCTION MAY RESULT IN PERSONAL INJURY, DEATH, OR SEVERE PROPERTY OR ENVIRONMENTAL DAMAGE. ST PRODUCTS WHICH ARE NOT SPECIFIED AS "AUTOMOTIVE GRADE" MAY ONLY BE USED IN AUTOMOTIVE APPLICATIONS AT USER'S OWN RISK.

Resale of ST products with provisions different from the statements and/or technical features set forth in this document shall immediately void any warranty granted by ST for the ST product or service described herein and shall not create or extend in any manner whatsoever, any liability of ST.

ST and the ST logo are trademarks or registered trademarks of ST in various countries.

Information in this document supersedes and replaces all information previously supplied.

The ST logo is a registered trademark of STMicroelectronics. All other names are the property of their respective owners.

© 2009 STMicroelectronics - All rights reserved

STMicroelectronics group of companies

Australia - Belgium - Brazil - Canada - China - Czech Republic - Finland - France - Germany - Hong Kong - India - Israel - Italy - Japan - Malaysia - Malta - Morocco - Philippines - Singapore - Spain - Sweden - Switzerland - United Kingdom - United States of America

www.st.com