

Fully integrated master transceiver IC

Data brief

Features

- Supply voltage from 18 to 32.5 V
- Programmable 200 mA push pull power stage (<math><2 \Omega @ 125 \text{ }^\circ\text{C}</math>)
- Supports up to 230 kHz
- 500 mA protected high-side driver
- Short-circuit and overcurrent outputs protection through current limitation and programmable cut-off current
- 3.3 V/5 V selectable 50 mA linear
- Regulator with $V_H = V_{CC}$ (with maximum power dissipation = 200 mW)
- 5 mA quasi type-2 input with programmable filter time
- Additional IEC61131-2 type-1 input with programmable filter time
- Diagnostic dual LED sequence generator and driver
- 5 V and 3.3 V compatible I/Os
- Overvoltage protection (>36 V)
- Integrated IEC61000-4-5 surge protection, with source impedance 500 Ω
- Overtemperature protection
- ESD protection
- Conform to IEC 61000-4-4
- Miniaturized: QFN 3.5 x 5 x 1 26 lead package

Applications

- Industrial sensors power-stage
- 24 V push pull line driver
- Fast I/O PLC interface, IO-Link conform



Description

The L6360 is a monolithic PHY input and output device. One channel is designed as HSD, while Channel 2 is configured as push pull power stage, ideally usable as 24 line driver, supporting communication speed up to 230 kHz.

C/Q_O output stage is programmable: high-side, low-side or push-pull; also cut-off current and cut-off current delay time, restart delay are programmable. Cut-off current and cut-off current delay time, combined with thermal shutdown and automatic restart, protect the device against over-load and short circuit. C/Q_O and L+ output stages are able to drive resistive, inductive and capacitive loads. Inductive loads can be driven up to 10 mJ.

Supply voltage is monitored and low voltage condition is detected. L6360 transfers, through the PHY2, data received or transmitted in the digital block from microcontroller by USART. For more details on complete system please refer to application schematic. To enable full IC control, regarding configuration and monitoring (i.e. fault condition stored in the status register) the communication between the system microcontroller and L6360 is based on a fast mode 2 wires interface. The L6360 has nine registers to manage the programmable parameters and the status of the IC. Monitored fault conditions are: Power On (L+ line), Overtemperature, C/Q over-load, linear regulator under-voltage and parity check. Internal LED driver blocks, in open drain configuration, provide two programmable sequences to drive two LEDs.

Figure 1. Block diagram

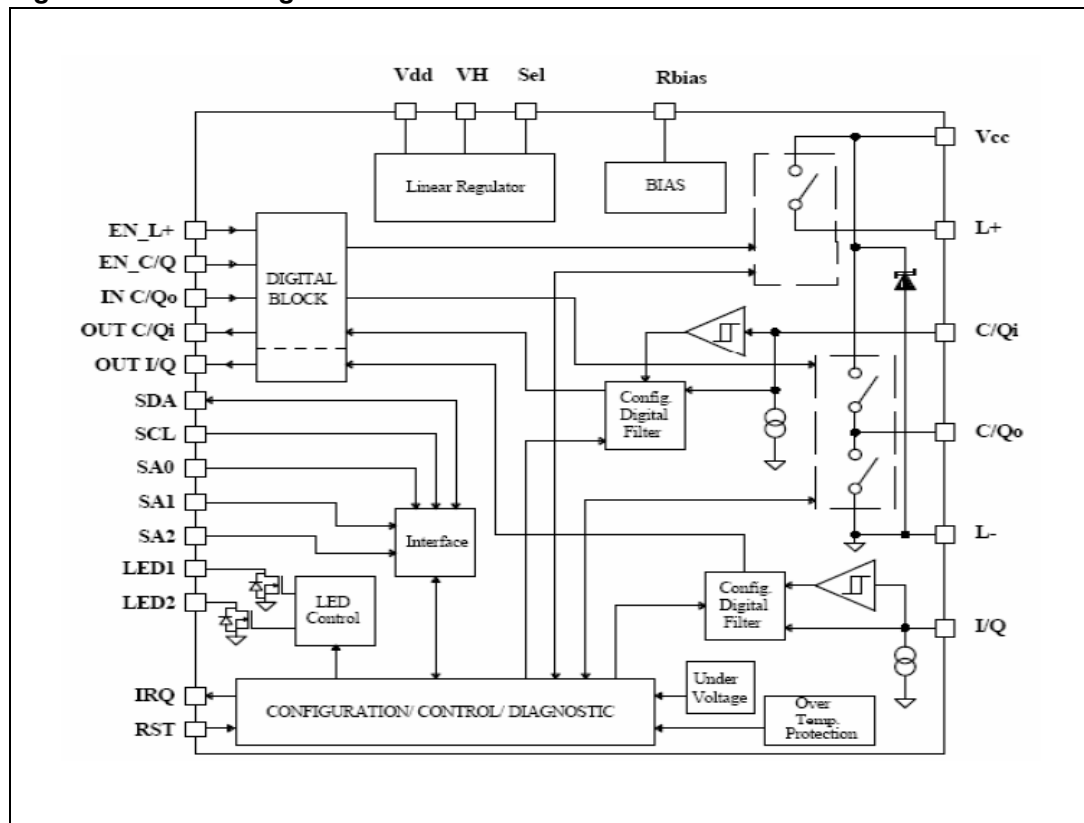

STMicroelectronics complete solution with device and master unit communicating each other and with μ C's.

Figure 2. Application schematic

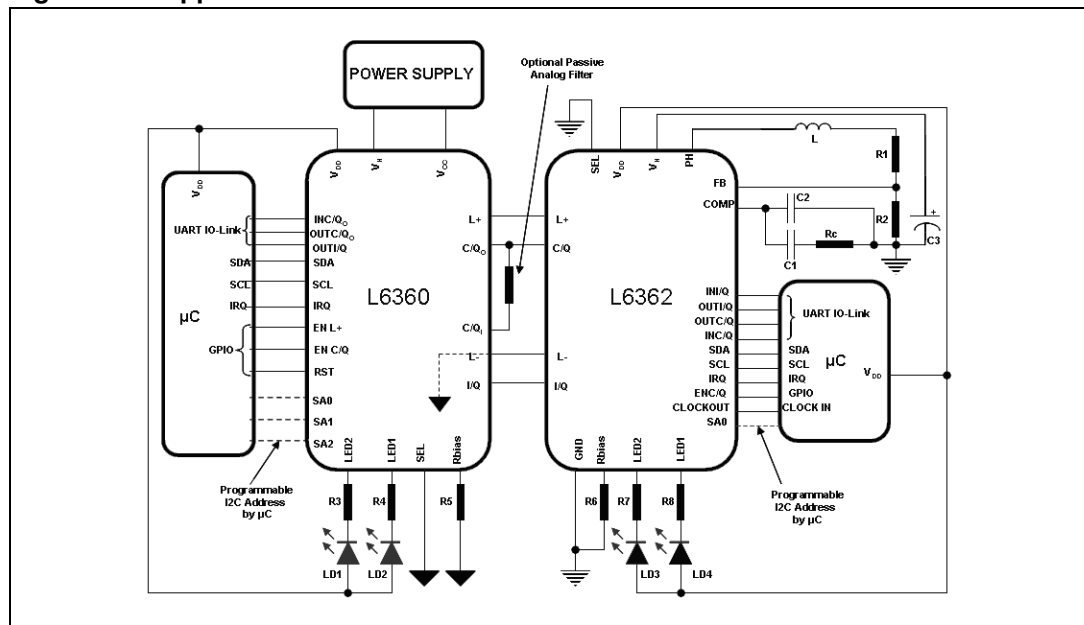

1 Revision history

Table 1. Document revision history

Date	Revision	Changes
22-Jul-2009	1	Initial release.

Please Read Carefully:

Information in this document is provided solely in connection with ST products. STMicroelectronics NV and its subsidiaries ("ST") reserve the right to make changes, corrections, modifications or improvements, to this document, and the products and services described herein at any time, without notice.

All ST products are sold pursuant to ST's terms and conditions of sale.

Purchasers are solely responsible for the choice, selection and use of the ST products and services described herein, and ST assumes no liability whatsoever relating to the choice, selection or use of the ST products and services described herein.

No license, express or implied, by estoppel or otherwise, to any intellectual property rights is granted under this document. If any part of this document refers to any third party products or services it shall not be deemed a license grant by ST for the use of such third party products or services, or any intellectual property contained therein or considered as a warranty covering the use in any manner whatsoever of such third party products or services or any intellectual property contained therein.

UNLESS OTHERWISE SET FORTH IN ST'S TERMS AND CONDITIONS OF SALE ST DISCLAIMS ANY EXPRESS OR IMPLIED WARRANTY WITH RESPECT TO THE USE AND/OR SALE OF ST PRODUCTS INCLUDING WITHOUT LIMITATION IMPLIED WARRANTIES OF MERCHANTABILITY, FITNESS FOR A PARTICULAR PURPOSE (AND THEIR EQUIVALENTS UNDER THE LAWS OF ANY JURISDICTION), OR INFRINGEMENT OF ANY PATENT, COPYRIGHT OR OTHER INTELLECTUAL PROPERTY RIGHT.

UNLESS EXPRESSLY APPROVED IN WRITING BY AN AUTHORIZED ST REPRESENTATIVE, ST PRODUCTS ARE NOT RECOMMENDED, AUTHORIZED OR WARRANTED FOR USE IN MILITARY, AIR CRAFT, SPACE, LIFE SAVING, OR LIFE SUSTAINING APPLICATIONS, NOR IN PRODUCTS OR SYSTEMS WHERE FAILURE OR MALFUNCTION MAY RESULT IN PERSONAL INJURY, DEATH, OR SEVERE PROPERTY OR ENVIRONMENTAL DAMAGE. ST PRODUCTS WHICH ARE NOT SPECIFIED AS "AUTOMOTIVE GRADE" MAY ONLY BE USED IN AUTOMOTIVE APPLICATIONS AT USER'S OWN RISK.

Resale of ST products with provisions different from the statements and/or technical features set forth in this document shall immediately void any warranty granted by ST for the ST product or service described herein and shall not create or extend in any manner whatsoever, any liability of ST.

ST and the ST logo are trademarks or registered trademarks of ST in various countries.

Information in this document supersedes and replaces all information previously supplied.

The ST logo is a registered trademark of STMicroelectronics. All other names are the property of their respective owners.

© 2009 STMicroelectronics - All rights reserved

STMicroelectronics group of companies

Australia - Belgium - Brazil - Canada - China - Czech Republic - Finland - France - Germany - Hong Kong - India - Israel - Italy - Japan - Malaysia - Malta - Morocco - Philippines - Singapore - Spain - Sweden - Switzerland - United Kingdom - United States of America

www.st.com