

Distributed by:

JAMECO[®]
ELECTRONICS

www.Jameco.com ♦ 1-800-831-4242

The content and copyrights of the attached
material are the property of its owner.

Jameco Part Number 924692



L7800AB/AC series

Precision 1A regulators

Feature summary

- Output current in excess of 1A
- Output voltages of 5; 6; 8; 9; 12; 15; 18; 20; 24V
- Thermal overload protection
- Output transition SOA protection
- 2% Output voltage tolerance
- Guaranteed in extended temperature range

Description

The L7800A series of three terminal positive regulators is available in TO-220, TO-220FP, and D²PAK packages and several fixed output voltages, making it useful in a wide range of applications. These regulators can provide local on-card regulation, eliminating the distribution problem associated with single point regulation. Each type employs internal current limiting, thermal shut-down and safe area protection, making it essentially indestructible. If adequate heat sinking is provided, they can

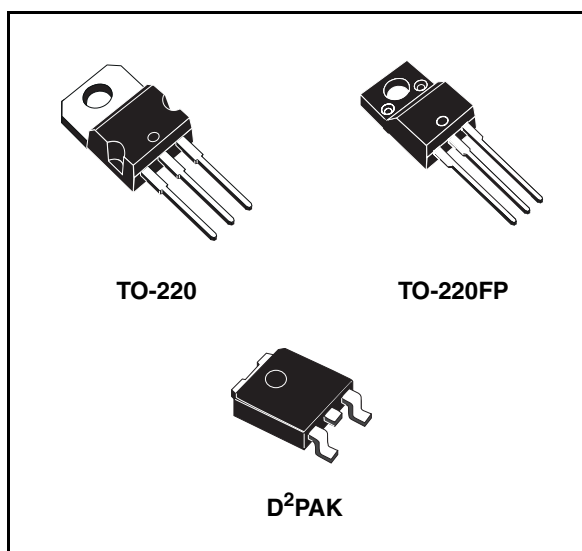

deliver over 1A output current, Although designed primarily as fixed voltage regulators, these devices can be used with external components to obtain adjustable voltage and currents.

Schematic diagram

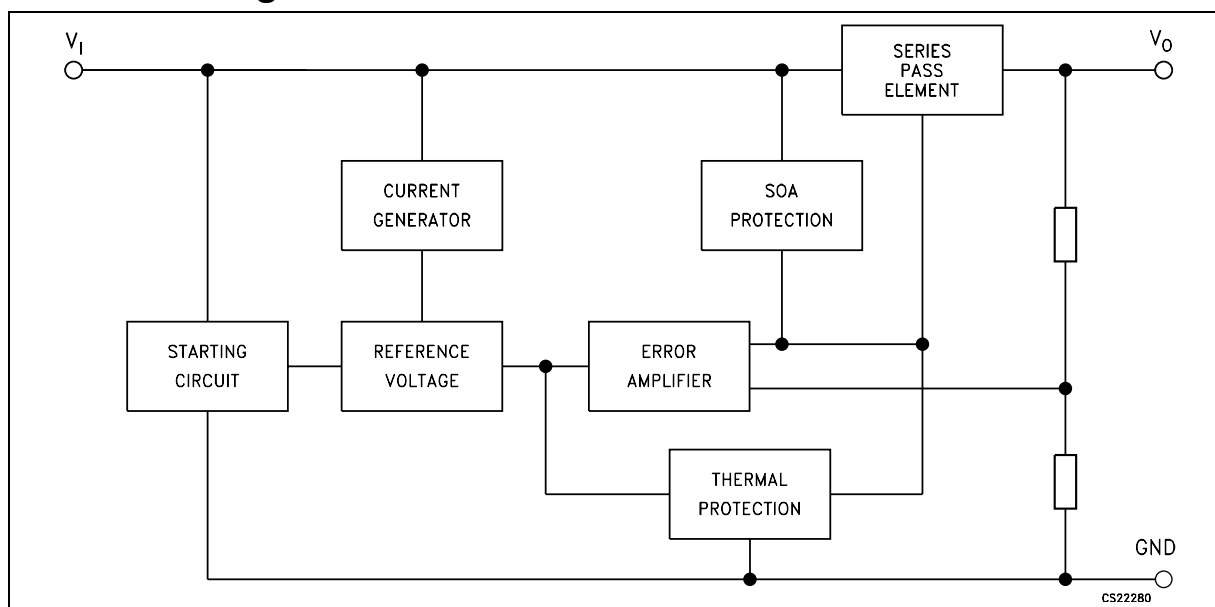

Contents

1	Pin configuration	3
2	Maximum ratings	4
3	Test circuits	5
4	Electrical characteristics	6
5	Application information	15
	5.1 Design consideration	15
6	Package mechanical data	18
7	Order code	25
8	Revision history	26

1 Pin configuration

Figure 1. Pin connections (top view)

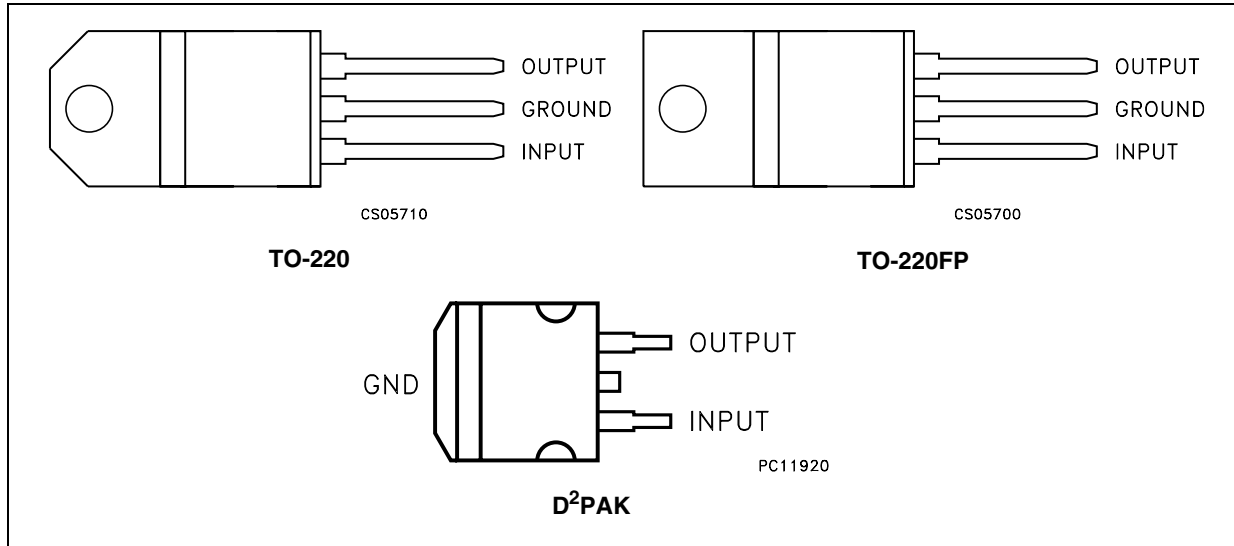
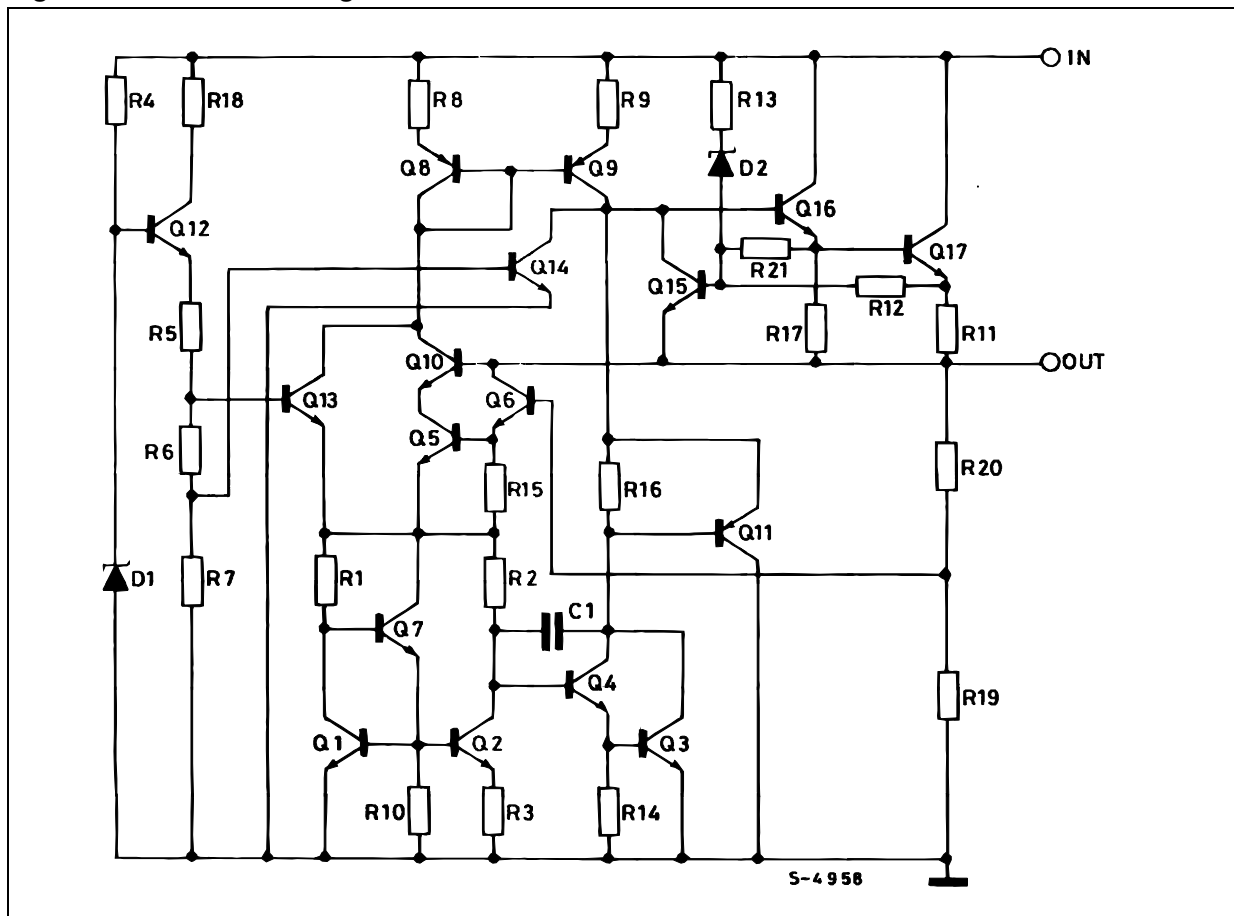

Figure 2. Schematic diagram



2 Maximum ratings

Table 1. Absolute maximum ratings

Symbol	Parameter		Value	Unit
V_I	DC Input voltage	for $V_O = 5$ to $18V$	35	V
		for $V_O = 20, 24V$	40	
I_O	Output current		Internally Limited	mA
P_D	Power dissipation		Internally Limited	mW
T_{STG}	Storage temperature range		-65 to 150	°C
T_{OP}	Operating junction temperature range	for L7800AC	0 to 150	°C
		for L7800AB	-40 to 125	

Note: Absolute Maximum Ratings are those values beyond which damage to the device may occur. Functional operation under these condition is not implied

Table 2. Thermal Data

Symbol	Parameter	TO-220	TO-220FP	D ² PAK	Unit
R_{thJC}	Thermal resistance junction-case	3	5	3	°C/W
R_{thJA}	Thermal resistance junction-ambient	50	60	62.5	°C/W

Figure 3. Application circuits

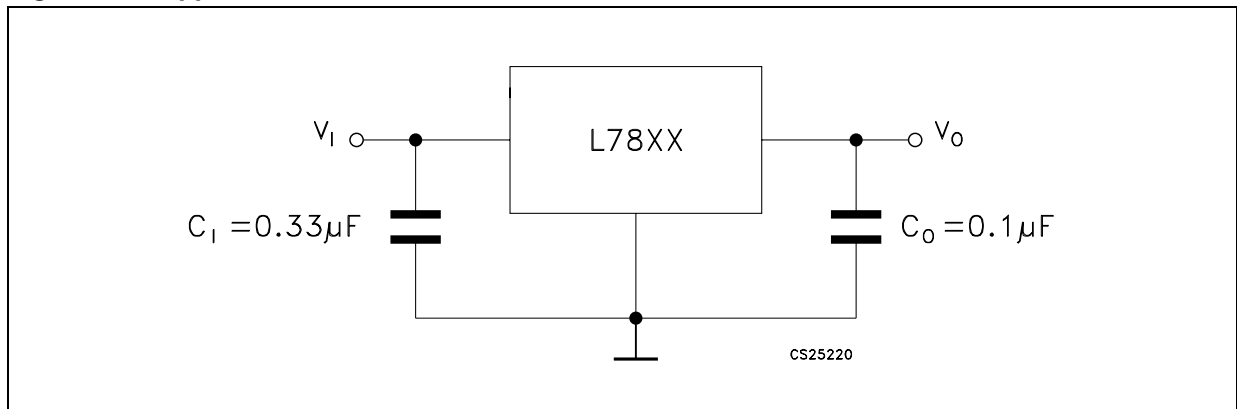

3 Test circuits

Figure 4. DC Parameter

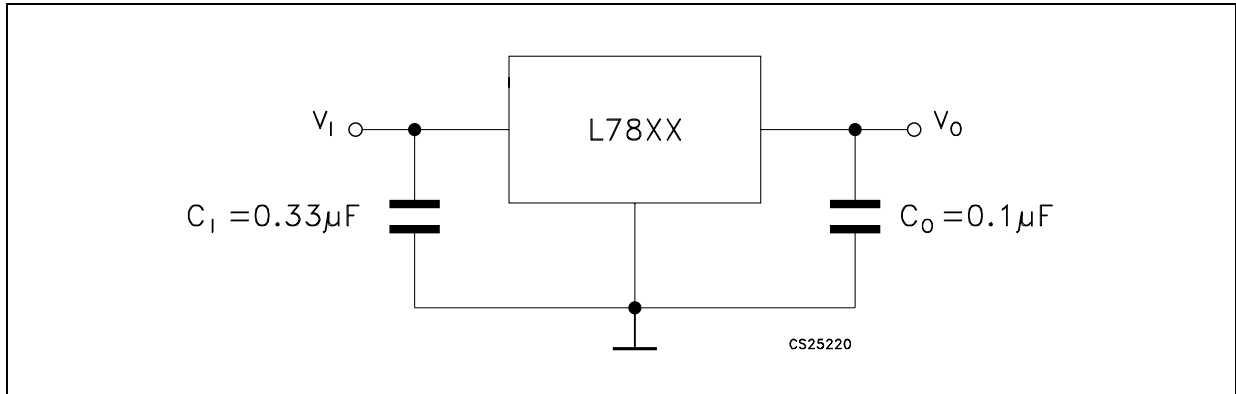

Figure 5. Load regulation

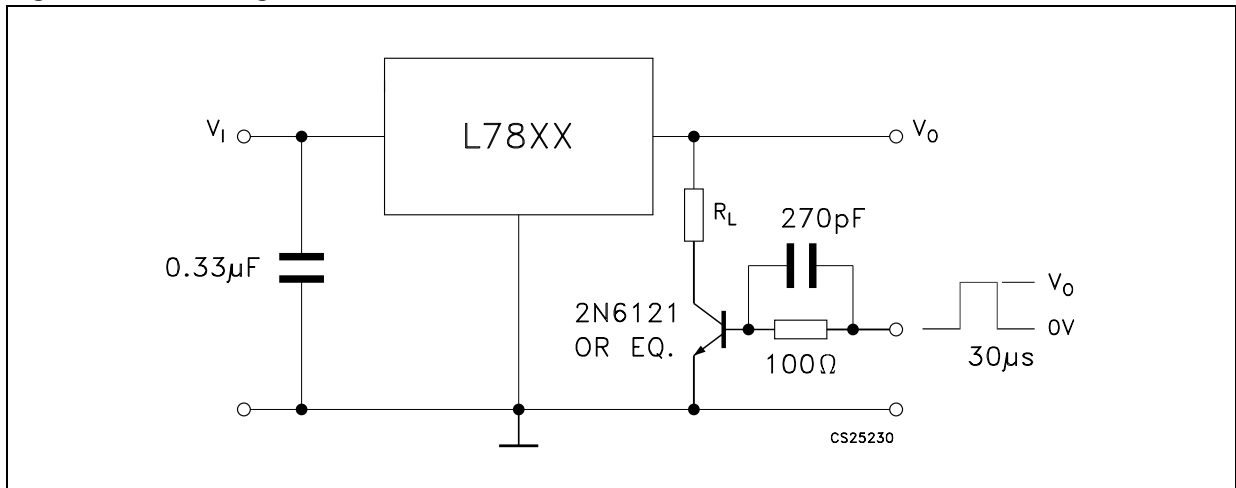
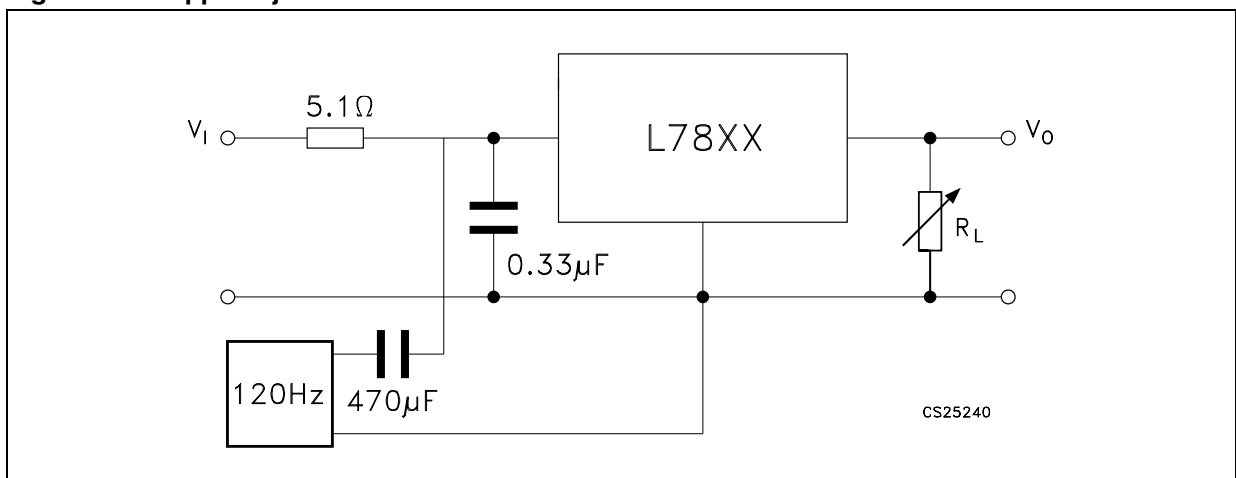

Figure 6. Ripple rejection



4 Electrical characteristics

Table 3. Electrical characteristics of L7805A ($V_I = 10V$, $I_O = 1A$, $T_J = 0$ to $150^\circ C$ (L7805AC), $T_J = -40$ to $125^\circ C$ (L7805AB), unless otherwise specified)

Symbol	Parameter	Test conditions	Min.	Typ.	Max.	Unit
V_O	Output voltage	$T_J = 25^\circ C$	4.9	5	5.1	V
V_O	Output voltage	$I_O = 5mA$ to $1A$, $P_O \leq 15W$ $V_I = 7.5$ to $20V$	4.8	5	5.2	V
$\Delta V_O^{(1)}$	Line regulation	$V_I = 7.5$ to $25V$, $I_O = 500$ mA		7	50	mV
		$V_I = 8$ to $12V$		10	50	mV
		$V_I = 8$ to $12V$, $T_J = 25^\circ C$		2	25	mV
		$V_I = 7.3$ to $20V$, $T_J = 25^\circ C$		7	50	mV
$\Delta V_O^{(*)}$	Load regulation	$I_O = 5mA$ to $1A$		25	100	mV
		$I_O = 5mA$ to $1.5A$, $T_J = 25^\circ C$		30	100	V
		$I_O = 250$ to $750mA$		8	50	V
I_q	Quiescent current	$T_J = 25^\circ C$		4.3	6	mA
					6	mA
ΔI_q	Quiescent current change	$V_I = 8$ to $25V$, $I_O = 500$ mA			0.8	mA
		$V_I = 7.5$ to $20V$, $T_J = 25^\circ C$			0.8	mA
		$I_O = 5mA$ to $1A$			0.5	mA
SVR	Supply voltage rejection	$V_I = 8$ to $18V$, $f = 120Hz$, $I_O = 500mA$		68		dB
V_d	Dropout voltage	$I_O = 1A$, $T_J = 25^\circ C$		2		V
eN	Output noise voltage	$T_A = 25^\circ C$, $B = 10Hz$ to $100KHz$		10		$\mu V/V_O$
R_O	Output resistance	$f = 1KHz$		17		$m\Omega$
I_{sc}	Short circuit current	$V_I = 35V$, $T_A = 25^\circ C$		0.2		A
I_{scp}	Short circuit peak current	$T_J = 25^\circ C$		2.2		A
$\Delta V_O/\Delta T$	Output voltage drift			-1.1		$mV/^\circ C$

1. Load and line regulation are specified at constant junction temperature. Changes in V_O due to heating effects must be taken into account separately. Pulse testing with low duty cycle is used.

Table 4. Electrical characteristics of L7806A ($V_I = 11V$, $I_O = 1A$, $T_J = 0$ to $150^\circ C$ (L7806AC), $T_J = -40$ to $125^\circ C$ (L7806AB), unless otherwise specified)

Symbol	Parameter	Test conditions	Min.	Typ.	Max.	Unit
V_O	Output voltage	$T_J = 25^\circ C$	5.88	6	6.12	V
V_O	Output voltage	$I_O = 5mA$ to $1A$, $P_O \leq 15W$ $V_I = 8.6$ to $21V$	5.76	6	6.24	V
$\Delta V_O^{(1)}$	Line regulation	$V_I = 8.6$ to $25V$, $I_O = 500$ mA		9	60	mV
		$V_I = 9$ to $13V$		11	60	mV
		$V_I = 9$ to $13V$, $T_J = 25^\circ C$		3	30	mV
		$V_I = 8.3$ to $21V$, $T_J = 25^\circ C$		9	60	mV
$\Delta V_O^{(1)}$	Load regulation	$I_O = 5mA$ to $1A$		25	100	mV
		$I_O = 5mA$ to $1.5A$, $T_J = 25^\circ C$		30	100	V
		$I_O = 250$ to $750mA$		10	50	V
I_q	Quiescent current	$T_J = 25^\circ C$		4.3	6	mA
					6	mA
ΔI_q	Quiescent current change	$V_I = 9$ to $25V$, $I_O = 500$ mA			0.8	mA
		$V_I = 8.6$ to $21V$, $T_J = 25^\circ C$			0.8	mA
		$I_O = 5mA$ to $1A$			0.5	mA
SVR	Supply voltage rejection	$V_I = 9$ to $19V$, $f = 120Hz$, $I_O = 500mA$		65		dB
V_d	Dropout voltage	$I_O = 1A$, $T_J = 25^\circ C$		2		V
eN	Output noise voltage	$T_A = 25^\circ C$, $B = 10Hz$ to $100KHz$		10		$\mu V/V_O$
R_O	Output resistance	$f = 1KHz$		17		$m\Omega$
I_{sc}	Short circuit current	$V_I = 35V$, $T_A = 25^\circ C$		0.2		A
I_{scp}	Short circuit peak current	$T_J = 25^\circ C$		2.2		A
$\Delta V_O/\Delta T$	Output voltage drift			-0.8		$mV/^\circ C$

1. Load and line regulation are specified at constant junction temperature. Changes in V_O due to heating effects must be taken into account separately. Pulse testing with low duty cycle is used.

Table 5. Electrical characteristics of L7808A ($V_I = 14V, I_O=1A, T_J = 0$ to $150^{\circ}C$ (L7808AC), $T_J = -40$ to $125^{\circ}C$ (L7808AB), unless otherwise specified)

Symbol	Parameter	Test conditions	Min.	Typ.	Max.	Unit
V_O	Output voltage	$T_J = 25^{\circ}C$	7.84	8	8.16	V
V_O	Output voltage	$I_O = 5mA$ to $1A, P_O \leq 5W$ $V_I = 10.6$ to $23V$	7.7	8	8.3	V
$\Delta V_O^{(1)}$	Line regulation	$V_I = 10.6$ to $25V, I_O = 500$ mA		12	80	mV
		$V_I = 11$ to $17V$		15	80	mV
		$V_I = 11$ to $17V, T_J = 25^{\circ}C$		5	40	mV
		$V_I = 10.4$ to $23V, T_J = 25^{\circ}C$		12	80	mV
$\Delta V_O^{(1)}$	Load regulation	$I_O = 5mA$ to $1A$		25	100	mV
		$I_O = 5mA$ to $1.5A, T_J = 25^{\circ}C$		30	100	V
		$I_O = 250$ to $750mA$		10	50	V
I_q	Quiescent current	$T_J = 25^{\circ}C$		4.3	6	mA
					6	mA
ΔI_q	Quiescent current change	$V_I = 11$ to $25V, I_O = 500$ mA			0.8	mA
		$V_I = 10.6$ to $23V, T_J = 25^{\circ}C$			0.8	mA
		$I_O = 5mA$ to $1A$			0.5	mA
SVR	Supply voltage rejection	$V_I = 11.5$ to $21.5V, f = 120Hz,$ $I_O = 500mA$		62		dB
V_d	Dropout voltage	$I_O = 1A, T_J = 25^{\circ}C$		2		V
eN	Output noise voltage	$T_A = 25^{\circ}C, B = 10Hz$ to $100KHz$		10		$\mu V/V_O$
R_O	Output resistance	$f = 1KHz$		18		$m\Omega$
I_{sc}	Short circuit current	$V_I = 35V, T_A = 25^{\circ}C$		0.2		A
I_{scp}	Short circuit peak current	$T_J = 25^{\circ}C$		2.2		A
$\Delta V_O/\Delta T$	Output voltage drift			-0.8		$mV/^{\circ}C$

1. Load and line regulation are specified at constant junction temperature. Changes in V_O due to heating effects must be taken into account separately. Pulse testing with low duty cycle is used.

Table 6. Electrical characteristics of L7809A ($V_I = 15V$, $I_O = 1A$, $T_J = 0$ to $150^\circ C$ (L7809AC), $T_J = -40$ to $125^\circ C$ (L7809AB), unless otherwise specified)

Symbol	Parameter	Test conditions	Min.	Typ.	Max.	Unit
V_O	Output voltage	$T_J = 25^\circ C$	8.82	9	9.18	V
V_O	Output voltage	$I_O = 5mA$ to $1A$, $P_O \leq 5W$ $V_I = 10.6$ to $23V$	8.65	9	9.35	V
$\Delta V_O^{(1)}$	Line regulation	$V_I = 10.6$ to $25V$, $I_O = 500$ mA		12	90	mV
		$V_I = 11$ to $17V$		15	90	mV
		$V_I = 11$ to $17V$, $T_J = 25^\circ C$		5	45	mV
		$V_I = 10.4$ to $23V$, $T_J = 25^\circ C$		12	90	mV
$\Delta V_O^{(1)}$	Load regulation	$I_O = 5mA$ to $1A$		25	100	mV
		$I_O = 5mA$ to $1.5A$, $T_J = 25^\circ C$		30	100	V
		$I_O = 250$ to $750mA$		10	50	V
I_q	Quiescent current	$T_J = 25^\circ C$		4.3	6	mA
					6	mA
ΔI_q	Quiescent current change	$V_I = 11$ to $25V$, $I_O = 500$ mA			0.8	mA
		$V_I = 10.6$ to $23V$, $T_J = 25^\circ C$			0.8	mA
		$I_O = 5mA$ to $1A$			0.5	mA
SVR	Supply voltage rejection	$V_I = 11.5$ to $21.5V$, $f = 120Hz$, $I_O = 500mA$		61		dB
V_d	Dropout voltage	$I_O = 1A$, $T_J = 25^\circ C$		2		V
eN	Output noise voltage	$T_A = 25^\circ C$, $B = 10Hz$ to $100KHz$		10		$\mu V/V_O$
R_O	Output resistance	$f = 1KHz$		18		$m\Omega$
I_{sc}	Short circuit current	$V_I = 35V$, $T_A = 25^\circ C$		0.2		A
I_{scp}	Short circuit peak current	$T_J = 25^\circ C$		2.2		A
$\Delta V_O/\Delta T$	Output voltage drift			-0.8		$mV/^\circ C$

1. Load and line regulation are specified at constant junction temperature. Changes in V_O due to heating effects must be taken into account separately. Pulse testing with low duty cycle is used.

Table 7. Electrical characteristics of L7812A ($V_I = 19V$, $I_O = 1A$, $T_J = 0$ to $150^\circ C$ (L7812AC), $T_J = -40$ to $125^\circ C$ (L7812AB), unless otherwise specified)

Symbol	Parameter	Test conditions	Min.	Typ.	Max.	Unit
V_O	Output voltage	$T_J = 25^\circ C$	11.75	12	12.25	V
V_O	Output voltage	$I_O = 5mA$ to $1A$, $P_O \leq 5W$ $V_I = 14.8$ to $27V$	11.5	12	12.5	V
$\Delta V_O^{(1)}$	Line regulation	$V_I = 14.8$ to $30V$, $I_O = 500$ mA		13	120	mV
		$V_I = 16$ to $12V$		16	120	mV
		$V_I = 16$ to $12V$, $T_J = 25^\circ C$		6	60	mV
		$V_I = 14.5$ to $27V$, $T_J = 25^\circ C$		13	120	mV
$\Delta V_O^{(1)}$	Load regulation	$I_O = 5mA$ to $1A$		25	100	mV
		$I_O = 5mA$ to $1.5A$, $T_J = 25^\circ C$		30	100	V
		$I_O = 250$ to $750mA$		10	50	V
I_q	Quiescent current	$T_J = 25^\circ C$		4.4	6	mA
					6	mA
ΔI_q	Quiescent current change	$V_I = 15$ to $30V$, $I_O = 500$ mA			0.8	mA
		$V_I = 14.8$ to $27V$, $T_J = 25^\circ C$			0.8	mA
		$I_O = 5mA$ to $1A$			0.5	mA
SVR	Supply voltage rejection	$V_I = 15$ to $25V$, $f = 120Hz$, $I_O = 500mA$		60		dB
V_d	Dropout voltage	$I_O = 1A$, $T_J = 25^\circ C$		2		V
eN	Output noise voltage	$T_A = 25^\circ C$, $B = 10Hz$ to $100KHz$		10		$\mu V/V_O$
R_O	Output resistance	$f = 1KHz$		18		$m\Omega$
I_{sc}	Short circuit current	$V_I = 35V$, $T_A = 25^\circ C$		0.2		A
I_{scp}	Short circuit peak current	$T_J = 25^\circ C$		2.2		A
$\Delta V_O/\Delta T$	Output voltage drift			-1		$mV/^\circ C$

1. Load and line regulation are specified at constant junction temperature. Changes in V_O due to heating effects must be taken into account separately. Pulse testing with low duty cycle is used.

Table 8. Electrical characteristics of L7815A ($V_I = 23V$, $I_O = 1A$, $T_J = 0$ to $150^\circ C$ (L7815AC), $T_J = -40$ to $125^\circ C$ (L7815AB), unless otherwise specified)

Symbol	Parameter	Test conditions	Min.	Typ.	Max.	Unit
V_O	Output voltage	$T_J = 25^\circ C$	14.7	15	15.3	V
V_O	Output voltage	$I_O = 5mA$ to $1A$, $P_O \leq 5W$ $V_I = 17.9$ to $30V$	14.4	15	15.6	V
$\Delta V_O^{(1)}$	Line regulation	$V_I = 17.9$ to $30V$, $I_O = 500$ mA		13	150	mV
		$V_I = 20$ to $26V$		16	150	mV
		$V_I = 20$ to $26V$, $T_J = 25^\circ C$		6	75	mV
		$V_I = 17.5$ to $30V$, $T_J = 25^\circ C$		13	150	mV
$\Delta V_O^{(1)}$	Load regulation	$I_O = 5mA$ to $1A$		25	100	mV
		$I_O = 5mA$ to $1.5A$, $T_J = 25^\circ C$		30	100	V
		$I_O = 250$ to $750mA$		10	50	V
I_q	Quiescent current	$T_J = 25^\circ C$		4.4	6	mA
					6	mA
ΔI_q	Quiescent current change	$V_I = 17.5$ to $30V$, $I_O = 500$ mA			0.8	mA
		$V_I = 17.5$ to $30V$, $T_J = 25^\circ C$			0.8	mA
		$I_O = 5mA$ to $1A$			0.5	mA
SVR	Supply voltage rejection	$V_I = 18.5$ to $28.5V$, $f = 120Hz$, $I_O = 500mA$		58		dB
V_d	Dropout voltage	$I_O = 1A$, $T_J = 25^\circ C$		2		V
eN	Output noise voltage	$T_A = 25^\circ C$, $B = 10Hz$ to $100KHz$		10		$\mu V/V_O$
R_O	Output resistance	$f = 1KHz$		19		$m\Omega$
I_{sc}	Short circuit current	$V_I = 35V$, $T_A = 25^\circ C$		0.2		A
I_{scp}	Short circuit peak current	$T_J = 25^\circ C$		2.2		A
$\Delta V_O/\Delta T$	Output voltage drift			-1		$mV/^\circ C$

1. Load and line regulation are specified at constant junction temperature. Changes in V_O due to heating effects must be taken into account separately. Pulse testing with low duty cycle is used.

Table 9. Electrical characteristics of L7818A ($V_I = 27V$, $I_O = 1A$, $T_J = 0$ to $150^\circ C$ (L7818AC), $T_J = -40$ to $125^\circ C$ (L7818AB), unless otherwise specified)

Symbol	Parameter	Test conditions	Min.	Typ.	Max.	Unit
V_O	Output voltage	$T_J = 25^\circ C$	17.64	18	18.36	V
V_O	Output voltage	$I_O = 5mA$ to $1A$, $P_O \leq 15W$ $V_I = 21$ to $33V$	17.3	18	18.7	V
$\Delta V_O^{(1)}$	Line regulation	$V_I = 21$ to $33V$, $I_O = 500$ mA		25	180	mV
		$V_I = 24$ to $30V$		28	180	mV
		$V_I = 24$ to $30V$, $T_J = 25^\circ C$		10	90	mV
		$V_I = 20.6$ to $33V$, $T_J = 25^\circ C$		5	180	mV
$\Delta V_O^{(1)}$	Load regulation	$I_O = 5mA$ to $1A$		25	100	mV
		$I_O = 5mA$ to $1.5A$, $T_J = 25^\circ C$		30	100	V
		$I_O = 250$ to $750mA$		10	50	V
I_q	Quiescent current	$T_J = 25^\circ C$		4.5	6	mA
					6	mA
ΔI_q	Quiescent current change	$V_I = 21$ to $33V$, $I_O = 500$ mA			0.8	mA
		$V_I = 21$ to $33V$, $T_J = 25^\circ C$			0.8	mA
		$I_O = 5mA$ to $1A$			0.5	mA
SVR	Supply voltage rejection	$V_I = 22$ to $32V$, $f = 120Hz$, $I_O = 500mA$		57		dB
V_d	Dropout voltage	$I_O = 1A$, $T_J = 25^\circ C$		2		V
eN	Output noise voltage	$T_A = 25^\circ C$, $B = 10Hz$ to $100KHz$		10		$\mu V/V_O$
R_O	Output resistance	$f = 1KHz$		19		m Ω
I_{sc}	Short circuit current	$V_I = 35V$, $T_A = 25^\circ C$		0.2		A
I_{scp}	Short circuit peak current	$T_J = 25^\circ C$		2.2		A
$\Delta V_O/\Delta T$	Output voltage drift			-1		mV/ $^\circ C$

1. Load and line regulation are specified at constant junction temperature. Changes in V_O due to heating effects must be taken into account separately. Pulse testing with low duty cycle is used.

Table 10. Electrical characteristics of L7820A ($V_I = 28V$, $I_O = 1A$, $T_J = 0$ to $150^\circ C$ (L7820AC), $T_J = -40$ to $125^\circ C$ (L7820AB), unless otherwise specified)

Symbol	Parameter	Test conditions	Min.	Typ.	Max.	Unit
V_O	Output voltage	$T_J = 25^\circ C$	19.6	20	20.4	V
V_O	Output voltage	$I_O = 5mA$ to $1A$, $P_O \leq 15W$ $V_I = 23$ to $35V$	19.2	20	20.8	V
$\Delta V_O^{(1)}$	Line regulation	$V_I = 23$ to $35V$, $I_O = 500$ mA			200	mV
		$V_I = 26$ to $32V$			200	mV
		$V_I = 26$ to $32V$, $T_J = 25^\circ C$			100	mV
		$V_I = 23$ to $32V$, $T_J = 25^\circ C$			200	mV
$\Delta V_O^{(1)}$	Load regulation	$I_O = 5mA$ to $1A$		25	100	mV
		$I_O = 5mA$ to $1.5A$, $T_J = 25^\circ C$		30	100	V
		$I_O = 250$ to $750mA$		10	50	V
I_q	Quiescent current	$T_J = 25^\circ C$		4.5	6	mA
					6	mA
ΔI_q	Quiescent current change	$V_I = 23$ to $35V$, $I_O = 500$ mA			0.8	mA
		$V_I = 23$ to $35V$, $T_J = 25^\circ C$			0.8	mA
		$I_O = 5mA$ to $1A$			0.5	mA
SVR	Supply voltage rejection	$V_I = 24$ to $35V$, $f = 120Hz$, $I_O = 500mA$		56		dB
V_d	Dropout voltage	$I_O = 1A$, $T_J = 25^\circ C$		2		V
eN	Output noise voltage	$T_A = 25^\circ C$, $B = 10Hz$ to $100KHz$		10		$\mu V/V_O$
R_O	Output resistance	$f = 1KHz$		20		m Ω
I_{sc}	Short circuit current	$V_I = 35V$, $T_A = 25^\circ C$		0.2		A
I_{scp}	Short circuit peak current	$T_J = 25^\circ C$		2.2		A
$\Delta V_O/\Delta T$	Output voltage drift			-1		mV/ $^\circ C$

1. Load and line regulation are specified at constant junction temperature. Changes in V_O due to heating effects must be taken into account separately. Pulse testing with low duty cycle is used.

Table 11. Electrical characteristics of L7824A ($V_I = 33V$, $I_O = 1A$, $T_J = 0$ to $150^\circ C$ (L7824AC), $T_J = -40$ to $125^\circ C$ (L7824AB), unless otherwise specified)

Symbol	Parameter	Test conditions	Min.	Typ.	Max.	Unit
V_O	Output voltage	$T_J = 25^\circ C$	19.6	20	20.4	V
V_O	Output voltage	$I_O = 5mA$ to $1A$, $P_O \leq 15W$ $V_I = 27.3$ to $38V$	19.2	20	20.8	V
$\Delta V_O^{(1)}$	Line regulation	$V_I = 27$ to $38V$, $I_O = 500$ mA			200	mV
		$V_I = 30$ to $36V$			200	mV
		$V_I = 30$ to $36V$, $T_J = 25^\circ C$			100	mV
		$V_I = 26.7$ to $38V$, $T_J = 25^\circ C$			200	mV
$\Delta V_O^{(1)}$	Load regulation	$I_O = 5mA$ to $1A$		25	100	mV
		$I_O = 5mA$ to $1.5A$, $T_J = 25^\circ C$		30	100	V
		$I_O = 250$ to $750mA$		10	50	V
I_q	Quiescent current	$T_J = 25^\circ C$		4.5	6	mA
					6	mA
ΔI_q	Quiescent current change	$V_I = 27.3$ to $38V$, $I_O = 500$ mA			0.8	mA
		$V_I = 27.3$ to $38V$, $T_J = 25^\circ C$			0.8	mA
		$I_O = 5mA$ to $1A$			0.5	mA
SVR	Supply voltage rejection	$V_I = 28$ to $38V$, $f = 120Hz$, $I_O = 500mA$		56		dB
V_d	Dropout voltage	$I_O = 1A$, $T_J = 25^\circ C$		2		V
eN	Output noise voltage	$T_A = 25^\circ C$, $B = 10Hz$ to $100KHz$		10		$\mu V/V_O$
R_O	Output resistance	$f = 1KHz$		20		$m\Omega$
I_{sc}	Short circuit current	$V_I = 35V$, $T_A = 25^\circ C$		0.2		A
I_{scp}	Short circuit peak current	$T_J = 25^\circ C$		2.2		A
$\Delta V_O/\Delta T$	Output voltage drift			-1		$mV/^\circ C$

1. Load and line regulation are specified at constant junction temperature. Changes in V_O due to heating effects must be taken into account separately. Pulse testing with low duty cycle is used.

5 Application information

5.1 Design consideration

The L7800A Series of fixed voltage regulators are designed with Thermal Overload Protection that shuts down the circuit when subjected to an excessive power overload condition, Internal Short-circuit Protection that limits the maximum current the circuit will pass, and Output transistor Safe-Area Compensation that reduces the output short-circuit current as the voltage across the pass transistor is increased. In many low current applications, compensation capacitors are not required. However, it is recommended that the regulator input be bypassed with capacitor if the regulator is connected to the power supply filter with long lengths, or if the output load capacitance is large. An input bypass capacitor should be selected to provide good high frequency characteristics to insure stable operation under all load conditions. A $0.33\mu\text{F}$ or larger tantalum, mylar or other capacitor having low internal impedance at high frequencies should be chosen. The bypass capacitor should be mounted with the shortest possible leads directly across the regulators input terminals. Normally good construction techniques should be used to minimize ground loops and lead resistance drops since the regulator has no external sense lead.

The addition of an operational amplifier allows adjustment to higher or intermediate values while retaining regulation characteristics. The minimum voltage obtained with the arrangement is 2V greater than the regulator voltage.

The circuit of figure 6 can be modified to provide supply protection against short circuit by adding a short circuit sense resistor, RSC, and an additional PNP transistor. The current sensing PNP must be able to handle the short circuit current of the three terminal regulator. Therefore a four ampere plastic power transistor is specified.

Figure 7. DC Parameter

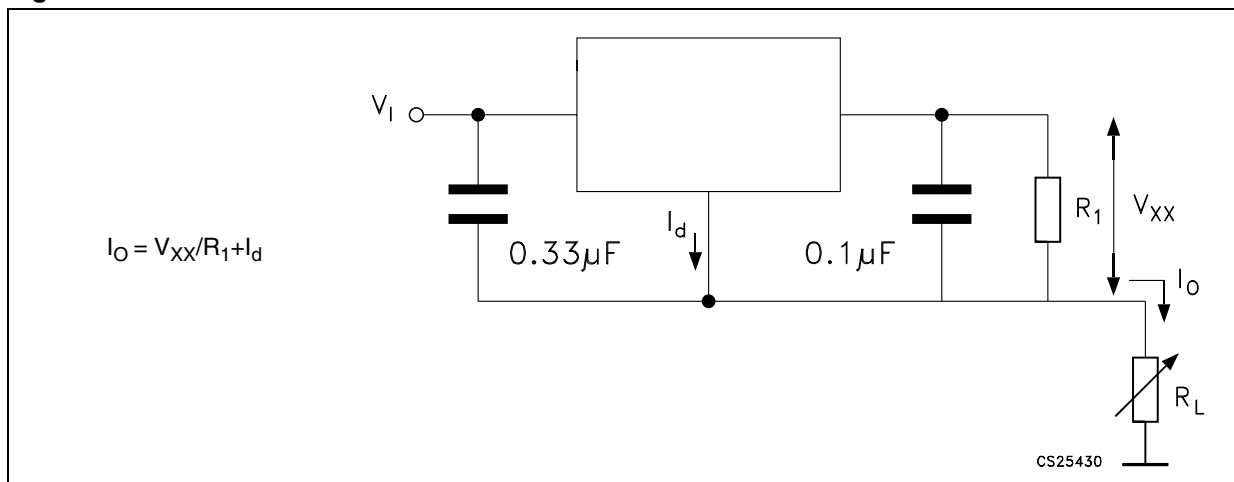

Figure 8. DC Parameter

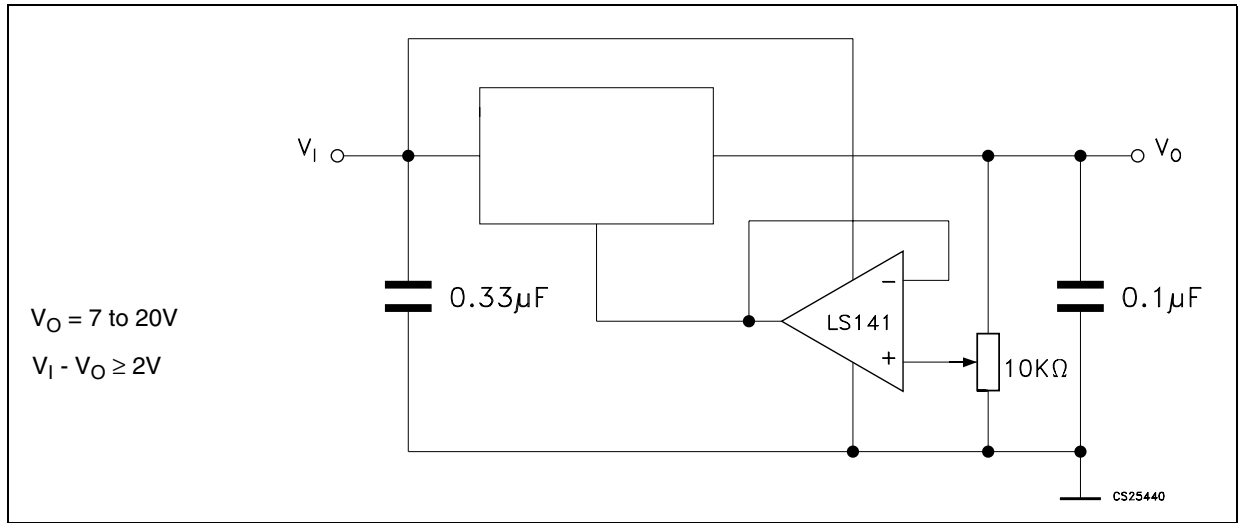

Figure 9. DC Parameter

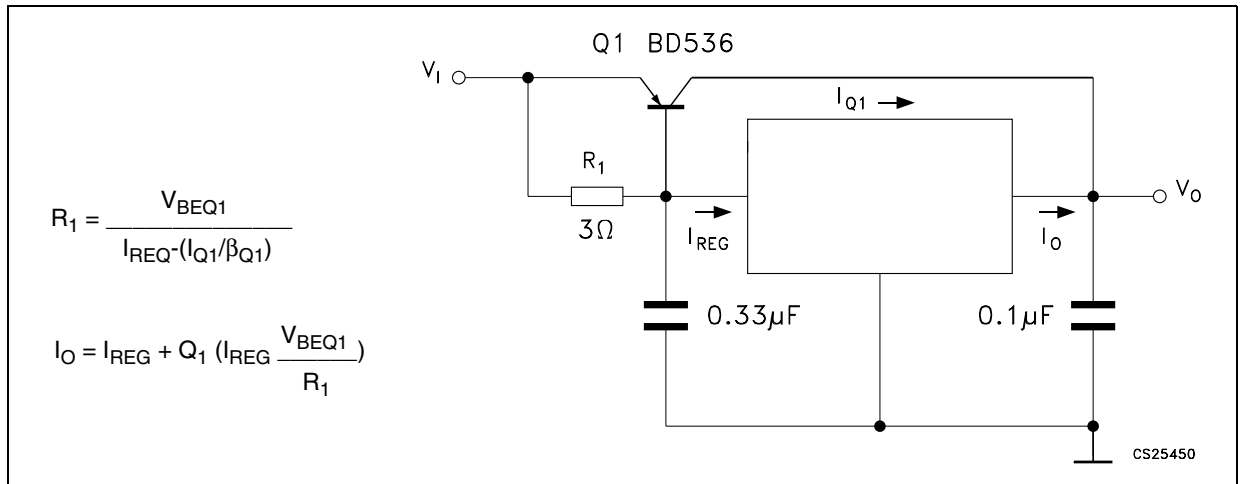
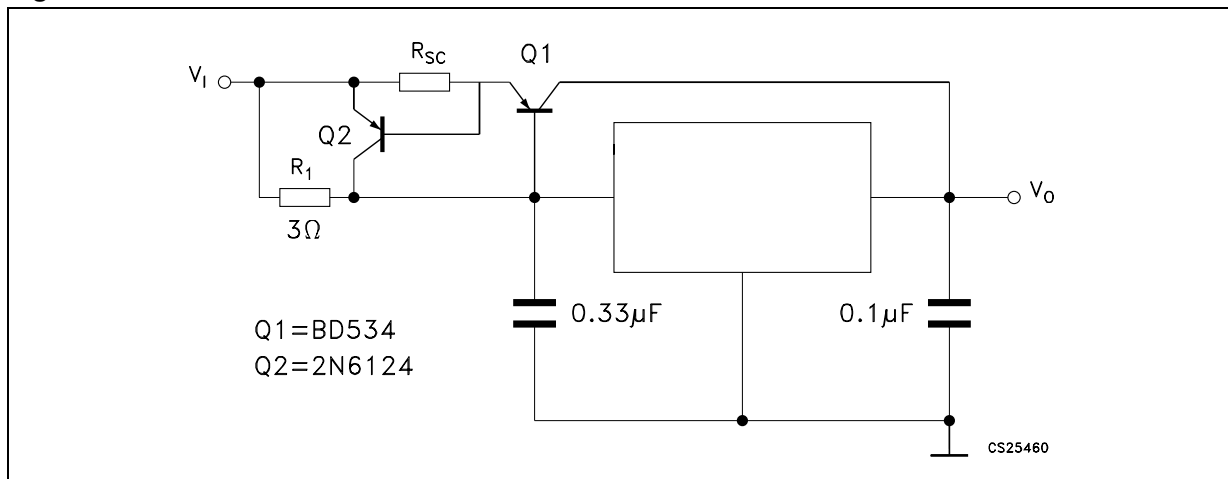

Figure 10. DC Parameter



6 Package mechanical data

In order to meet environmental requirements, ST offers these devices in ECOPACK® packages. These packages have a Lead-free second level interconnect. The category of second Level Interconnect is marked on the package and on the inner box label, in compliance with JEDEC Standard JESD97. The maximum ratings related to soldering conditions are also marked on the inner box label. ECOPACK is an ST trademark. ECOPACK specifications are available at: www.st.com.

TO-220 MECHANICAL DATA

DIM.	mm.			inch		
	MIN.	TYP	MAX.	MIN.	TYP.	MAX.
A	4.40		4.60	0.173		0.181
C	1.23		1.32	0.048		0.051
D	2.40		2.72	0.094		0.107
D1		1.27			0.050	
E	0.49		0.70	0.019		0.027
F	0.61		0.88	0.024		0.034
F1	1.14		1.70	0.044		0.067
F2	1.14		1.70	0.044		0.067
G	4.95		5.15	0.194		0.203
G1	2.4		2.7	0.094		0.106
H2	10.0		10.40	0.393		0.409
L2		16.4			0.645	
L4	13.0		14.0	0.511		0.551
L5	2.65		2.95	0.104		0.116
L6	15.25		15.75	0.600		0.620
L7	6.2		6.6	0.244		0.260
L9	3.5		3.93	0.137		0.154
DIA.	3.75		3.85	0.147		0.151

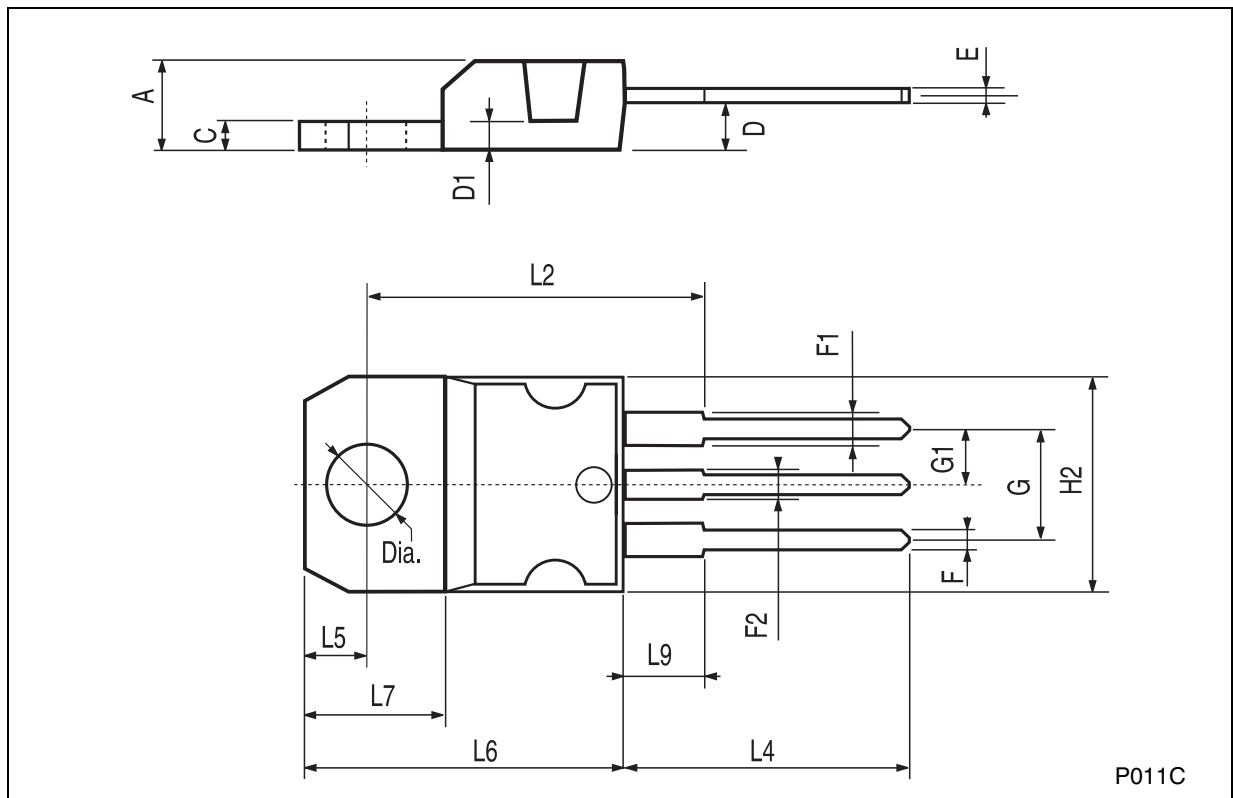

TO-220FP MECHANICAL DATA

DIM.	mm.			inch		
	MIN.	TYP	MAX.	MIN.	TYP.	MAX.
A	4.40		4.60	0.173		0.181
B	2.5		2.7	0.098		0.106
D	2.5		2.75	0.098		0.108
E	0.45		0.70	0.017		0.027
F	0.75		1	0.030		0.039
F1	1.15		1.50	0.045		0.059
F2	1.15		1.50	0.045		0.059
G	4.95		5.2	0.194		0.204
G1	2.4		2.7	0.094		0.106
H	10.0		10.40	0.393		0.409
L2		16			0.630	
L3	28.6		30.6	1.126		1.204
L4	9.8		10.6	0.385		0.417
L5	2.9		3.6	0.114		0.142
L6	15.9		16.4	0.626		0.645
L7	9		9.3	0.354		0.366
DIA.	3		3.2	0.118		0.126

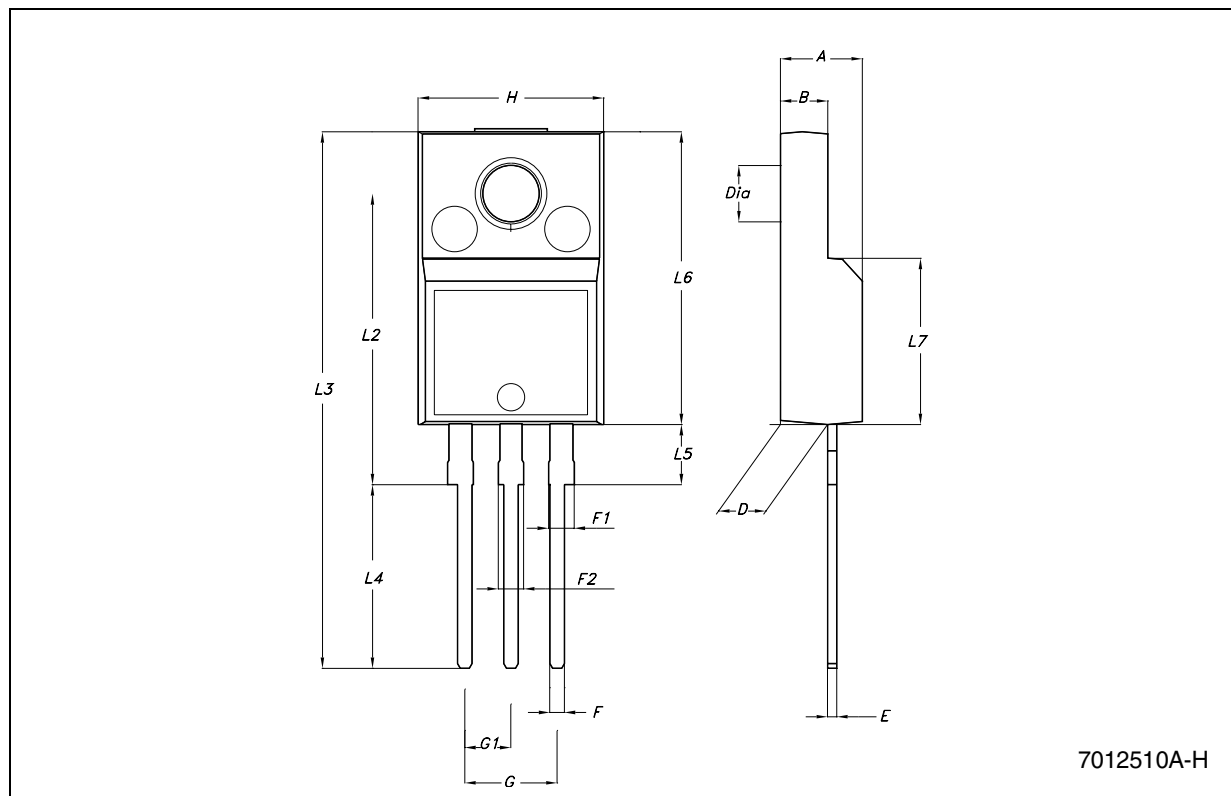

D²PAK (A TYPE) MECHANICAL DATA

DIM.	mm.			inch		
	MIN.	TYP	MAX.	MIN.	TYP.	MAX.
A	4.4		4.6	0.173		0.181
A1	0.03		0.23	0.001		0.009
b	0.7		0.93	0.027		0.036
b2	1.14		1.7	0.044		0.067
c	0.45		0.6	0.017		0.023
c2	1.23		1.36	0.048		0.053
D	8.95		9.35	0.352		0.368
D1	8			0.315		
E	10		10.4	0.393		0.409
E1	8.5			0.335		
e		2.54			0.100	
e1	4.88		5.28	0.192		0.208
H	15		15.85	0.590		0.624
J1	2.49		2.69	0.098		0.106
L	2.29		2.79	0.090		0.110
L1	1.27		1.4	0.050		0.055
L2	1.3		1.75	0.051		0.069
R		0.4			0.016	
V2	0°		8°	0°		8°

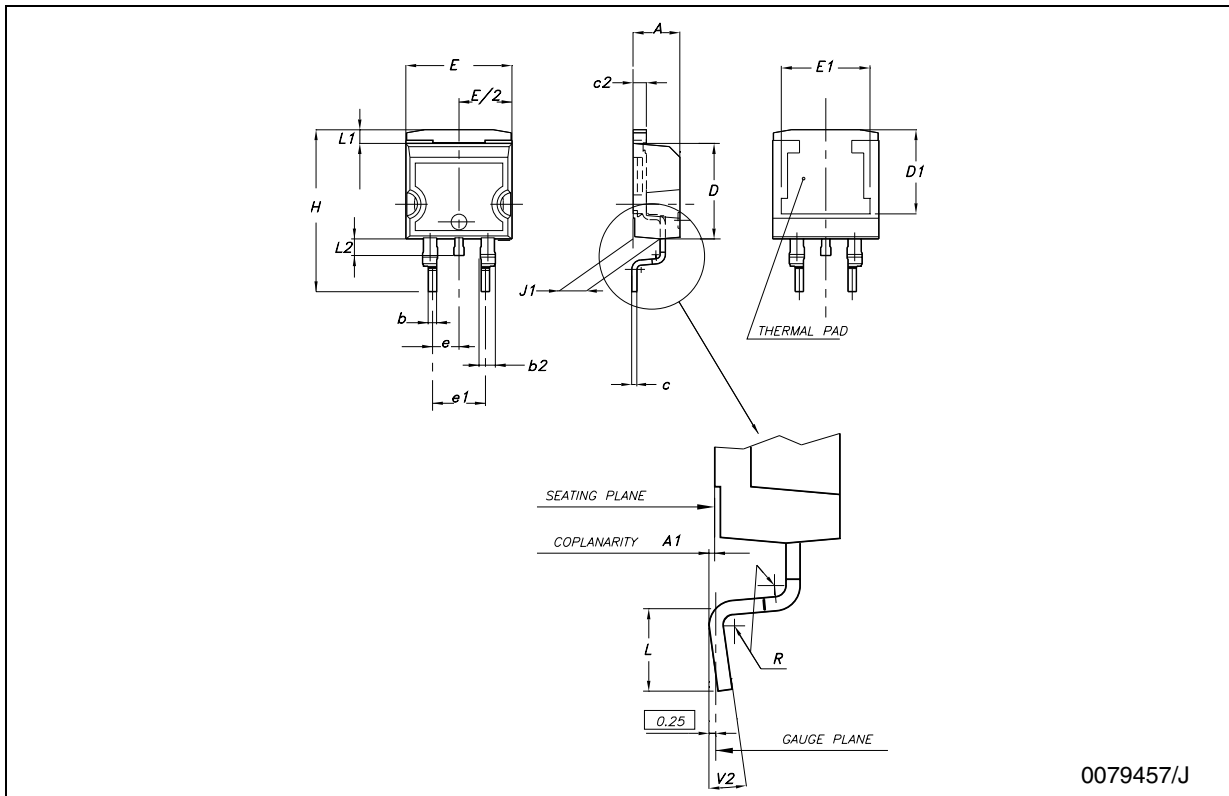

0079457/J

D²PAK (C TYPE) MECHANICAL DATA

DIM.	mm.			inch		
	MIN.	TYP	MAX.	MIN.	TYP.	MAX.
A	4.3		4.7	0.169		0.185
A1	0		0.20	0.000		0.008
b	0.70		0.90	0.028		0.035
b2	1.17		1.37	0.046		0.054
c	0.45	0.50	0.6	0.018	0.020	0.024
c2	1.25	1.30	1.40	0.049	0.051	0.055
D	9.0	9.2	9.4	0.354	0.362	0.370
D1	7.5			0.295		
E	9.8		10.2	0.386		0.402
E1	7.5			0.295		
e		2.54			0.100	
e1		5.08			0.200	
H	15	15.30	15.60	0.591	0.602	0.614
J1	2.20		2.60	0.087		0.102
L	1.79		2.79	0.070		0.110
L1	1.0		1.4	0.039		0.055
L2	1.2		1.6	0.047		0.063
R		0.3			0.012	
V2	0°		3°	0°		3°

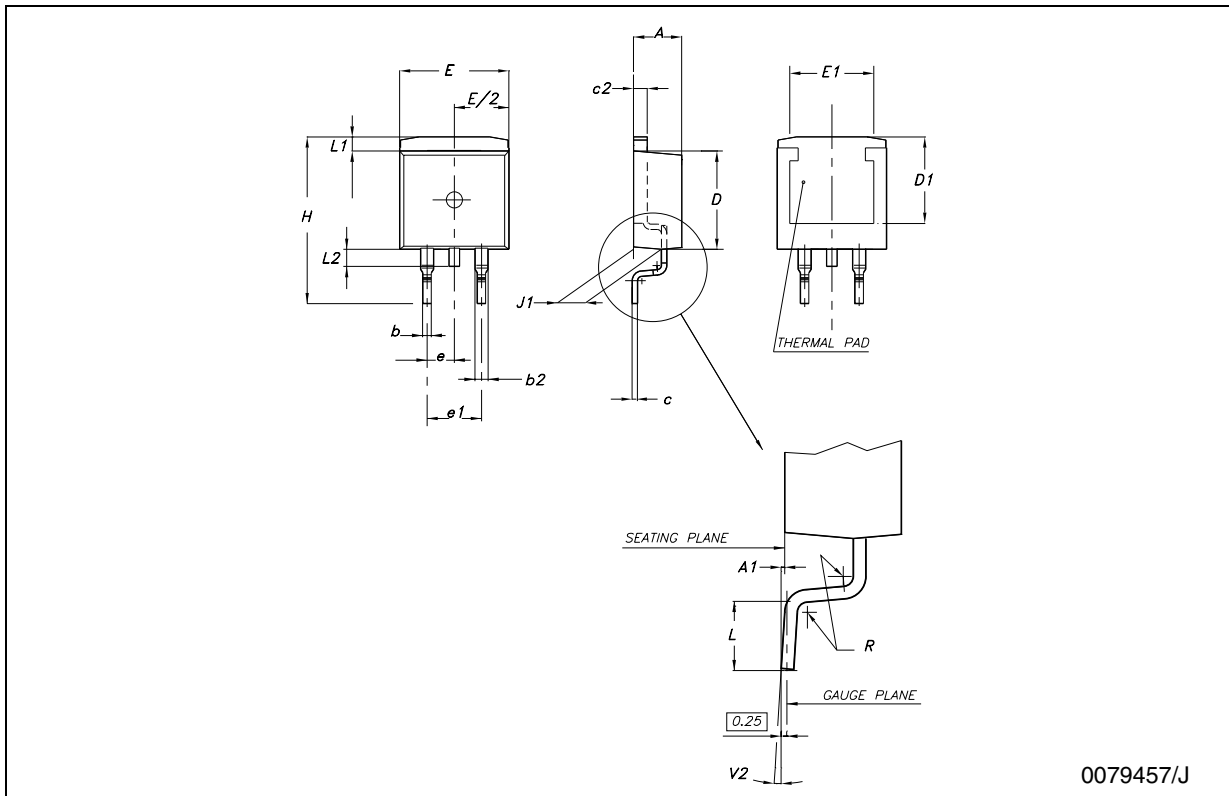

0079457/J

Tape & Reel D²PAK-P²PAK-D²PAK/A-P²PAK/A MECHANICAL DATA

DIM.	mm.			inch		
	MIN.	TYP	MAX.	MIN.	TYP.	MAX.
A			180			7.086
C	12.8	13.0	13.2	0.504	0.512	0.519
D	20.2			0.795		
N	60			2.362		
T			14.4			0.567
Ao	10.50	10.6	10.70	0.413	0.417	0.421
Bo	15.70	15.80	15.90	0.618	0.622	0.626
Ko	4.80	4.90	5.00	0.189	0.193	0.197
Po	3.9	4.0	4.1	0.153	0.157	0.161
P	11.9	12.0	12.1	0.468	0.472	0.476

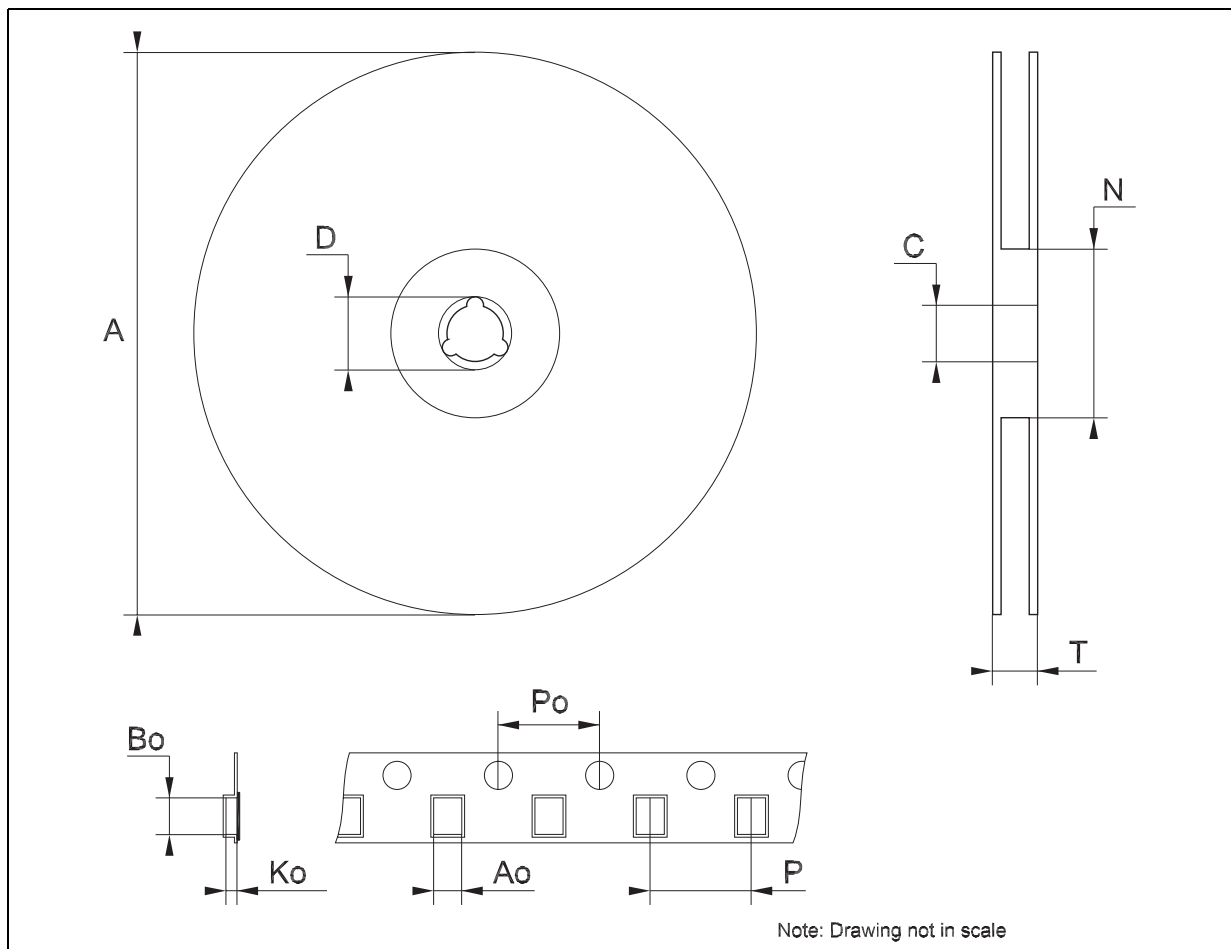

7 Order code

Table 12. Order code

Part numbers	Packaging				Output voltage
	TO-220	TO-220FP	D ² PAK (A Type)	D ² PAK (C Type)	
L7805AB	L7805ABV	L7805ABP	L7805ABD2T-TR		5 V
L7805AC	L7805ACV	L7805ACP	L7805ACD2T-TR	L7805AC-D2TR	5 V
L7806AB	L7806ABV	L7806ABP ⁽¹⁾	L7806ABD2T-TR		6 V
L7806AC	L7806ACV	L7806ACP ⁽¹⁾	L7806ACD2T-TR		6 V
L7808AB	L7808ABV	L7808ABP	L7808ABD2T-TR		8 V
L7808AC	L7808ACV	L7808ACP	L7808ACD2T-TR		8 V
L7809AB	L7809ABV	L7809ABP	L7809ABD2T-TR		9 V
L7809AC	L7809ACV	L7809ACP	L7809ACD2T-TR		9 V
L7812AB	L7812ABV	L7812ABP ⁽¹⁾	L7812ABD2T-TR		12 V
L7812AC	L7812ACV	L7812ACP	L7812ACD2T-TR		12 V
L7815AB	L7815ABV	L7815ABP	L7815ABD2T-TR		15 V
L7815AC	L7815ACV	L7815ACP ⁽¹⁾	L7815ACD2T-TR		15 V
L7818AB	L7818ABV	L7818ABP	L7818ABD2T-TR ⁽¹⁾		18 V
L7818AC	L7818ACV	L7818ACP ⁽¹⁾	L7818ACD2T-TR ⁽¹⁾		18 V
L7820AB	L7820ABV ⁽¹⁾	L7820ABP ⁽¹⁾	L7820ABD2T-TR ⁽¹⁾		20 V
L7820AC	L7820ACV	L7820ACP ⁽¹⁾	L7820ACD2T-TR ⁽¹⁾		20 V
L7824AB	L7824ABV	L7824ABP	L7824ABD2T-TR ⁽¹⁾		24 V
L7824AC	L7824ACV	L7824ACP ⁽¹⁾	L7824ACD2T-TR ⁽¹⁾		24 V

1. Available on request.

8 Revision history

Table 13. Revision history

Date	Revision	Changes
21-Jun-2004	9	Document updating.
04-Aug-2006	10	Order Codes has been updated and new template.

Please Read Carefully:

Information in this document is provided solely in connection with ST products. STMicroelectronics NV and its subsidiaries ("ST") reserve the right to make changes, corrections, modifications or improvements, to this document, and the products and services described herein at any time, without notice.

All ST products are sold pursuant to ST's terms and conditions of sale.

Purchasers are solely responsible for the choice, selection and use of the ST products and services described herein, and ST assumes no liability whatsoever relating to the choice, selection or use of the ST products and services described herein.

No license, express or implied, by estoppel or otherwise, to any intellectual property rights is granted under this document. If any part of this document refers to any third party products or services it shall not be deemed a license grant by ST for the use of such third party products or services, or any intellectual property contained therein or considered as a warranty covering the use in any manner whatsoever of such third party products or services or any intellectual property contained therein.

UNLESS OTHERWISE SET FORTH IN ST'S TERMS AND CONDITIONS OF SALE ST DISCLAIMS ANY EXPRESS OR IMPLIED WARRANTY WITH RESPECT TO THE USE AND/OR SALE OF ST PRODUCTS INCLUDING WITHOUT LIMITATION IMPLIED WARRANTIES OF MERCHANTABILITY, FITNESS FOR A PARTICULAR PURPOSE (AND THEIR EQUIVALENTS UNDER THE LAWS OF ANY JURISDICTION), OR INFRINGEMENT OF ANY PATENT, COPYRIGHT OR OTHER INTELLECTUAL PROPERTY RIGHT.

UNLESS EXPRESSLY APPROVED IN WRITING BY AN AUTHORIZED ST REPRESENTATIVE, ST PRODUCTS ARE NOT RECOMMENDED, AUTHORIZED OR WARRANTED FOR USE IN MILITARY, AIR CRAFT, SPACE, LIFE SAVING, OR LIFE SUSTAINING APPLICATIONS, NOR IN PRODUCTS OR SYSTEMS WHERE FAILURE OR MALFUNCTION MAY RESULT IN PERSONAL INJURY, DEATH, OR SEVERE PROPERTY OR ENVIRONMENTAL DAMAGE. ST PRODUCTS WHICH ARE NOT SPECIFIED AS "AUTOMOTIVE GRADE" MAY ONLY BE USED IN AUTOMOTIVE APPLICATIONS AT USER'S OWN RISK.

Resale of ST products with provisions different from the statements and/or technical features set forth in this document shall immediately void any warranty granted by ST for the ST product or service described herein and shall not create or extend in any manner whatsoever, any liability of ST.

ST and the ST logo are trademarks or registered trademarks of ST in various countries.

Information in this document supersedes and replaces all information previously supplied.

The ST logo is a registered trademark of STMicroelectronics. All other names are the property of their respective owners.

© 2006 STMicroelectronics - All rights reserved

STMicroelectronics group of companies

Australia - Belgium - Brazil - Canada - China - Czech Republic - Finland - France - Germany - Hong Kong - India - Israel - Italy - Japan - Malaysia - Malta - Morocco - Singapore - Spain - Sweden - Switzerland - United Kingdom - United States of America

www.st.com