



# LM2931XX - LM2931AXX33 LM2931AXX50 - LM2931BXX50

## Very low drop voltage regulators with inhibit function

### Features

- Very low dropout voltage (0.15 V typ. at 10 mA load)
- Low quiescent current (typ. 2.5 mA, at 100 mA load)
- Output current up to 100 mA
- Adjustable (from  $V_{OUT} = 2.5$  V only SO-8) and fixed (3.3 V & 5 V) output voltage version
- Internal current and thermal limit
- Load dump protection up to 60 V
- Reverse transient protection up to -50 V
- Temperature range: -40 to 125 °C
- Package available: TO-92, DPAK, TO-220, SO-8 (with inhibit control)

### Description

The LM2931xx are very low drop regulators. The very low drop voltage and the low quiescent current make them particular suitable for low noise, low power applications and in battery powered systems. In the 8 pin configuration (SO-8), fully compatible to the older L78L00 family, a shut down Logic Control function is available.

This means that when the device is used as a local regulator is possible to put a part of the

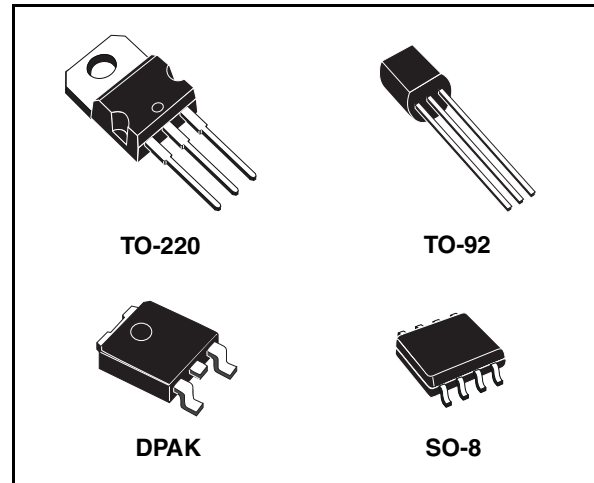

board in stand-by decreasing the total power consumption. Ideal for automotive application the LM2931 is protected from reverse battery installations or 2 battery jumps. During the transient, such as a load dump (60 V) when the input voltage can exceed the specified maximum operating input voltage (26 V), the regulator will automatically shut down to protect both internal circuit and the load.

**Table 1. Device summary**

Order codes					Output voltage
Packages					
TO-220	DPAK	TO-92 (BAG)	TO-92 (Ammopak) <sup>(1)</sup>	SO-8	
		LM2931AZ33R		LM2931AD33R	3.3 V
LM2931AV50	LM2931ADT50R	LM2931AZ50R	LM2931AZ50AP	LM2931AD50R	5.0 V
LM2931BV50	LM2931BDT50R	LM2931BZ50R	LM2931BZ50AP	LM2931BD50R	5.0 V
				LM2931D-R	2.5 to 26 V

1. Please note that in these cases pins are shaped according to tape & reel specifications.

# Contents

1	Diagram .....	3
2	Pin configuration .....	4
3	Maximum ratings .....	5
4	Application circuits .....	6
5	Electrical characteristics .....	7
6	Typical characteristics .....	11
7	Package mechanical data .....	15
8	Revision history .....	23

# 1 Diagram

Figure 1. Schematic diagram

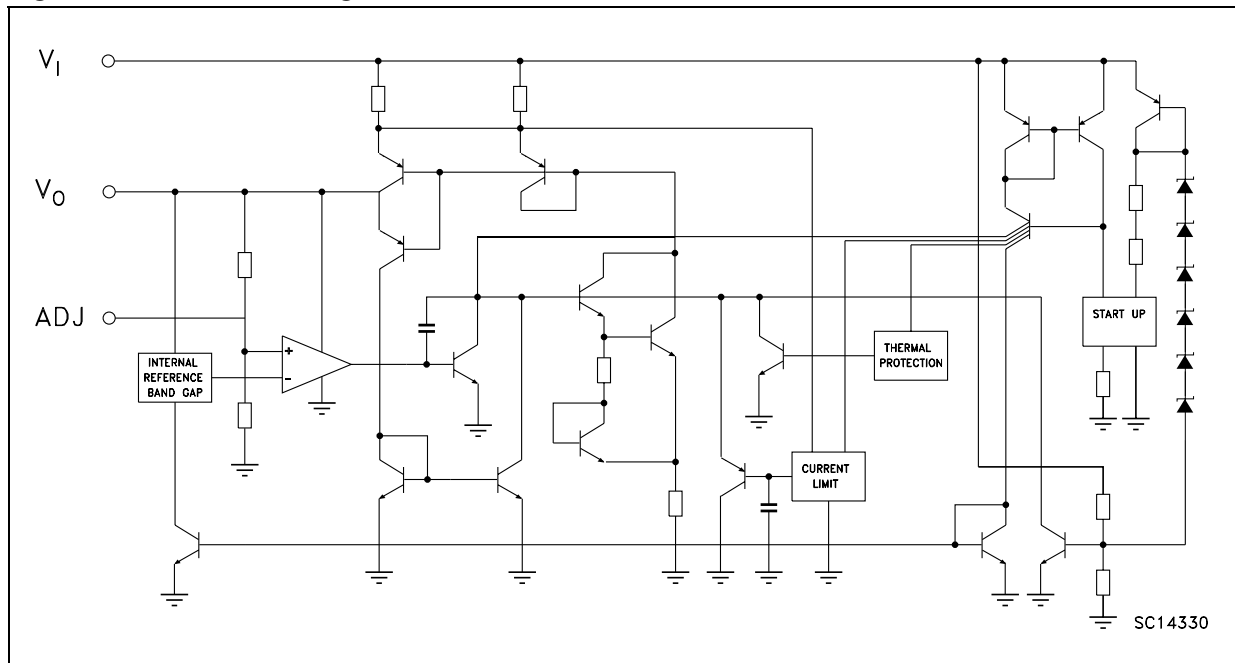

## 2 Pin configuration

Figure 2. Pin connections (top view)

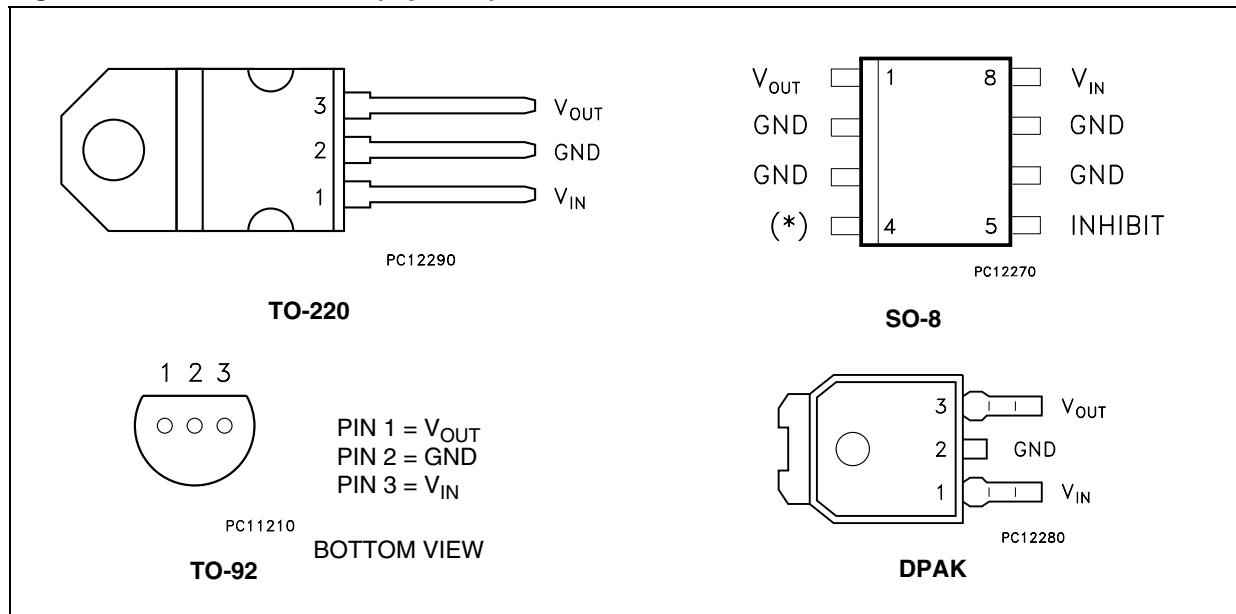

### 3 Maximum ratings

**Table 2. Absolute maximum ratings**

Symbol	Parameter	Value	Unit
$V_I$	DC positive input voltage	40	V
$V_I$	DC reverse input voltage	-15	V
$V_I$	Transient input voltage ( $\tau < 100$ ms)	60	V
$V_I$	Transient reverse input voltage ( $\tau < 100$ ms)	-50	V
$V_{INH}$	Inhibit input voltage	40	V
$I_O$	Output current	Internally Limited	
$T_{STG}$	Storage temperature range	-65 to 150	°C
$T_{OP}$	Operating junction temperature range	-40 to 125	°C

*Note: Absolute maximum ratings are those values beyond which damage to the device may occur. Functional operation under these condition is not implied*

**Table 3. Thermal data**

Symbol	Parameter	TO-220	SO-8	DPAK	TO-92	Unit
$R_{thJC}$	Thermal resistance junction-case	3	20	8		°C/W
$R_{thJA}$	Thermal resistance junction-ambient	50	55 <sup>(1)</sup>	100	200	°C/W

1. Considering 6 cm<sup>2</sup> of copper board heat-sink.

## 4 Application circuits

Figure 3. Application circuit for fixed output

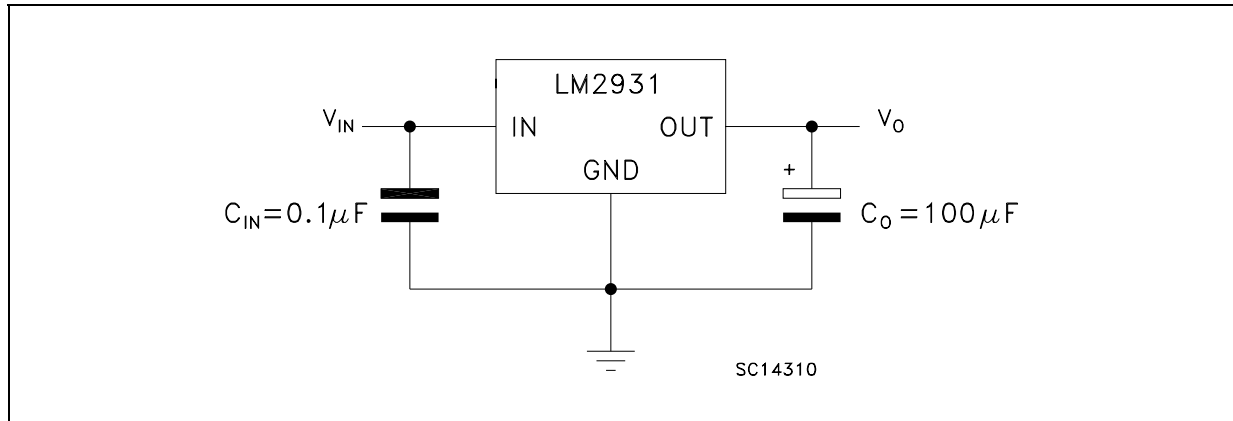
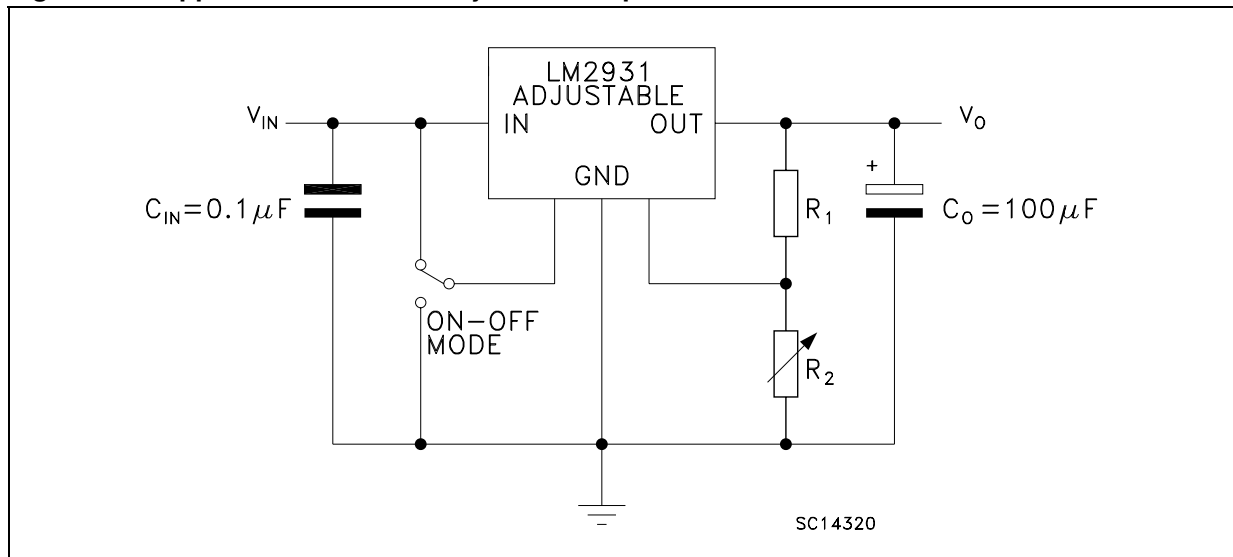

Figure 4. Application circuit for adjustable output



$R_1$  suggested value = 27 K $\Omega$

$$V_O = V_{REF} (R_1 + R_2) / R_1$$

## 5 Electrical characteristics

**Table 4. Electrical characteristics of LM2931Axx33** (refer to the application circuit [Figure 3](#),  $T_J = 25^\circ\text{C}$ ,  $C_I = 0.1\ \mu\text{F}$ ,  $C_O = 100\ \mu\text{F}$ ,  $V_I = 14\ \text{V}$ ,  $I_O = 10\ \text{mA}$ ,  $V_{INH} = 0\ \text{V}$ , unless otherwise specified).

Symbol	Parameter	Test conditions	Min.	Typ.	Max.	Unit
$V_I$	Maximum operating input voltage	$I_O = 10\ \text{mA}$ , $T_J = -40\ \text{to}\ 125^\circ\text{C}$	26	37		V
$V_O$	Output voltage		3.135	3.3	3.425	V
$V_O$	Output voltage	$I_O = 100\ \text{mA}$ , $V_I = 6\ \text{to}\ 26\ \text{V}$ $T_J = -40\ \text{to}\ 125^\circ\text{C}$	3.135	3.3	3.465	V
$\Delta V_O$	Line regulation	$V_I = 9\ \text{to}\ 16\ \text{V}$		2	10	mV
		$V_I = 6\ \text{to}\ 26\ \text{V}$		4	33	
$\Delta V_O$	Load regulation	$I_O = 5\ \text{to}\ 100\ \text{mA}$		10	33	mV
$V_d$	Dropout voltage <sup>(1)</sup> <sup>(2)</sup>	$I_O = 10\ \text{mA}$		90	250	mV
		$I_O = 100\ \text{mA}$		250	600	
$I_d$	Quiescent current ON MODE	$I_O = 100\ \text{mA}$		2.5	30	mA
	OFF MODE	$V_{INH} = 2.5\ \text{V}$ , $R_{LOAD} = 330\ \Omega$		0.3	1	mA
$I_{SC}$	Short circuit current		100	300		mA
SVR	Supply voltage rejection	$I_O = 100\ \text{mA}$ , $V_I = 14 \pm 2\ \text{V}$ $f = 120\ \text{Hz}$ , $T_J = -40\ \text{to}\ 125^\circ\text{C}$	55	78		dB
$V_{IL}$	Control input voltage low	$T_J = -40\ \text{to}\ 125^\circ\text{C}$		2	1.2	V
$V_{IH}$	Control input voltage high	$T_J = -40\ \text{to}\ 125^\circ\text{C}$	3.25	2		V
$I_{INH}$	Inhibit input current	$V_{INH} = 2.5\ \text{V}$		22	50	$\mu\text{A}$
$V_I$	Transient input voltage	$R_{LOAD} = 330\ \Omega$ , $\tau < 100\ \text{ms}$	60	70		V
$V_I$	Reverse polarity input voltage	$V_O = \pm 0.3\ \text{V}$ , $R_{LOAD} = 330\ \Omega$	-15	-50		V
$V_I$	Reverse polarity input voltage transient	$R_{LOAD} = 330\ \Omega$ , $\tau < 100\ \text{ms}$	-50			V
eN	Output noise voltage	$B = 10\ \text{Hz to}\ 100\ \text{KHz}$		330		$\mu\text{V}_{RMS}$

1. Reference Voltage is measured from  $V_{OUT}$  to ADJ pin.

2.  $V_d$  measured when the output voltage has dropped 100mV from the nominal value obtained at 14V.

**Table 5. Electrical characteristics of LM2931Axx50** (refer to the application circuit [Figure 3](#),  $T_J = 25\text{ }^\circ\text{C}$ ,  $C_I = 0.1\text{ }\mu\text{F}$ ,  $C_O = 100\text{ }\mu\text{F}$ ,  $V_I = 14\text{ V}$ ,  $I_O = 10\text{ mA}$ ,  $V_{INH} = 0\text{ V}$ , unless otherwise specified).

Symbol	Parameter	Test conditions	Min.	Typ.	Max.	Unit
$V_I$	Maximum operating input voltage	$I_O = 10\text{ mA}$ , $T_J = -40\text{ to }125^\circ\text{C}$	26	37		V
$V_O$	Output voltage		4.81	5	5.19	V
$V_O$	Output voltage	$I_O = 100\text{ mA}$ , $V_I = 6\text{ to }26\text{ V}$ $T_J = -40\text{ to }125^\circ\text{C}$	4.75	5	5.25	V
$\Delta V_O$	Line regulation	$V_I = 9\text{ to }16\text{ V}$		2	10	mV
		$V_I = 6\text{ to }26\text{ V}$		4	30	
$\Delta V_O$	Load regulation	$I_O = 5\text{ to }100\text{ mA}$		15	50	mV
$V_d$	Dropout voltage <sup>(1)</sup> <sup>(2)</sup>	$I_O = 10\text{ mA}$		90	200	mV
		$I_O = 100\text{ mA}$		250	600	
$I_d$	Quiescent current ON MODE	$I_O = 100\text{ mA}$		2.5	30	mA
	OFF MODE	$V_{INH} = 2.5\text{ V}$ , $R_{LOAD} = 500\text{ }\Omega$		0.3	1	mA
$I_{SC}$	Short circuit current		100	300		mA
SVR	Supply voltage rejection	$I_O = 100\text{ mA}$ , $V_I = 14 \pm 2\text{ V}$ $f = 120\text{ Hz}$ , $T_J = -40\text{ to }125^\circ\text{C}$	55	75		dB
$V_{IL}$	Control input voltage low	$T_J = -40\text{ to }125^\circ\text{C}$		2	1.2	V
$V_{IH}$	Control input voltage high	$T_J = -40\text{ to }125^\circ\text{C}$	3.25	2		V
$I_{INH}$	Inhibit input current	$V_{INH} = 2.5\text{ V}$		22	50	$\mu\text{A}$
$V_I$	Transient input voltage	$R_{LOAD} = 500\text{ }\Omega$ , $\tau < 100\text{ms}$	60	70		V
$V_I$	Reverse polarity input voltage	$V_O = \pm 0.3\text{ V}$ , $R_{LOAD} = 500\text{ }\Omega$	-15	-50		V
$V_I$	Reverse polarity input voltage transient	$R_{LOAD} = 500\text{ }\Omega$ , $\tau < 100\text{ms}$	-50			V
eN	Output noise voltage	$B = 10\text{ Hz to }100\text{ KHz}$		500		$\mu\text{V}_{RMS}$

1. Reference Voltage is measured from  $V_{OUT}$  to ADJ pin.

2.  $V_d$  measured when the output voltage has dropped 100mV from the nominal value obtained at 14V.

**Table 6. Electrical characteristics of LM2931Bxx50** (refer to the application circuit [Figure 3](#),  $T_J = 25\text{ }^\circ\text{C}$ ,  $C_I = 0.1\text{ }\mu\text{F}$ ,  $C_O = 100\text{ }\mu\text{F}$ ,  $V_I = 14\text{ V}$ ,  $I_O = 10\text{ mA}$ ,  $V_{INH} = 0\text{ V}$ , unless otherwise specified).

Symbol	Parameter	Test conditions	Min.	Typ.	Max.	Unit
$V_I$	Maximum operating input voltage	$I_O = 10\text{ mA}$ , $T_J = -40\text{ to }125^\circ\text{C}$	26	37		V
$V_O$	Output voltage		4.75	5	5.25	V
$V_O$	Output voltage	$I_O = 100\text{ mA}$ , $V_I = 6\text{ to }26\text{ V}$ $T_J = -40\text{ to }125^\circ\text{C}$	4.5	5	5.5	V
$\Delta V_O$	Line regulation	$V_I = 9\text{ to }16\text{ V}$		2	10	mV
		$V_I = 6\text{ to }26\text{ V}$		4	30	
$\Delta V_O$	Load regulation	$I_O = 5\text{ to }100\text{ mA}$		15	50	mV
$V_d$	Dropout voltage <sup>(1)</sup> <sup>(2)</sup>	$I_O = 10\text{ mA}$		90	200	mV
		$I_O = 100\text{ mA}$		250	600	
$I_d$	Quiescent current ON MODE	$I_O = 100\text{ mA}$		2.5	30	mA
	OFF MODE	$V_{INH} = 2.5\text{ V}$ , $R_{LOAD} = 500\text{ }\Omega$		0.3	1	mA
$I_{SC}$	Short circuit current		100	300		mA
SVR	Supply voltage rejection	$I_O = 100\text{ mA}$ , $V_I = 14 \pm 2\text{ V}$ $f = 120\text{ Hz}$ , $T_J = -40\text{ to }125^\circ\text{C}$	55	75		dB
$V_{IL}$	Control input voltage low	$T_J = -40\text{ to }125^\circ\text{C}$		2	1.2	V
$V_{IH}$	Control input voltage high	$T_J = -40\text{ to }125^\circ\text{C}$	3.25	2		V
$I_{INH}$	Inhibit input current	$V_{INH} = 2.5\text{ V}$		22	50	$\mu\text{A}$
$V_I$	Transient input voltage	$R_{LOAD} = 500\text{ }\Omega$ , $\tau < 100\text{ms}$	60	70		V
$V_I$	Reverse polarity input voltage	$V_O = \pm 0.3\text{ V}$ , $R_{LOAD} = 500\text{ }\Omega$	-15	-50		V
$V_I$	Reverse polarity input voltage transient	$R_{LOAD} = 500\text{ }\Omega$ , $\tau < 100\text{ms}$	-50			V
eN	Output noise voltage	$B = 10\text{ Hz to }100\text{ KHz}$		500		$\mu\text{V}_{RMS}$

1. Reference Voltage is measured from  $V_{OUT}$  to ADJ pin.

2.  $V_d$  measured when the output voltage has dropped 100mV from the nominal value obtained at 14V.

**Table 7. Electrical characteristics of LM2931xx** (refer to the application circuit [Figure 4](#) with  $R_1 = 27\text{ k}\Omega$  and  $R_2 = 40.5\text{ k}\Omega$ ,  $T_J = 25\text{ }^\circ\text{C}$ ,  $C_1 = 0.1\text{ }\mu\text{F}$ ,  $C_O = 100\text{ }\mu\text{F}$ ,  $V_I = 14\text{ V}$ ,  $I_O = 10\text{ mA}$ ,  $V_{INH} = 0\text{ V}$ , unless otherwise specified).

Symbol	Parameter	Test conditions	Min.	Typ.	Max.	Unit
$V_I$	Maximum Operating Input Voltage	$I_O = 10\text{ mA}$ , $T_J = -40\text{ to }125^\circ\text{C}$	26	37		V
$V_{REF}$	Reference Voltage <sup>(1)</sup>		1.14	1.2	1.26	V
$V_{REF}$	Reference Voltage <sup>(1)</sup>	$I_O = 100\text{ mA}$ , $T_J = -40\text{ to }125^\circ\text{C}$	1.08	1.2	1.32	V
$\Delta V_O$	Line Regulation	$V_I = 3.6\text{ to }26\text{ V}$		0.6	4.5	mV
$\Delta V_O$	Load Regulation	$I_O = 5\text{ to }100\text{ mA}$		9	30	mV
$V_d$	Dropout Voltage <sup>(1) (2)</sup>	$I_O = 10\text{ mA}$		90	200	mV
		$I_O = 100\text{ mA}$		250	600	
$I_d$	Quiescent Current ON MODE	$I_O = 100\text{ mA}$		2.5	30	mA
	OFF MODE	$V_{INH} = 2.5\text{ V}$ , $R_{LOAD} = 300\text{ }\Omega$		0.3	1	mA
$I_{SC}$	Short Circuit Current		100	300		mA
SVR	Supply Voltage Rejection	$I_O = 100\text{ mA}$ , $V_I = 14 \pm 2\text{ V}$ $f = 120\text{ Hz}$ , $T_J = -40\text{ to }125^\circ\text{C}$	55	80		dB
$V_{IL}$	Control Input Voltage Low	$T_J = -40\text{ to }125^\circ\text{C}$		2	1.2	V
$V_{IH}$	Control Input Voltage High	$T_J = -40\text{ to }125^\circ\text{C}$	3.25	2		V
$I_{INH}$	Inhibit Input Current	$V_{INH} = 2.5\text{ V}$		22	50	$\mu\text{A}$
$V_I$	Transient Input Voltage	$R_{LOAD} = 300\text{ }\Omega$ , $\tau < 100\text{ms}$	60	70		V
$V_I$	Reverse Polarity Input Voltage	$V_O = \pm 0.3\text{ V}$ , $R_{LOAD} = 300\text{ }\Omega$	-15	-50		V
$V_I$	Reverse Polarity Input Voltage Transient	$R_{LOAD} = 300\text{ }\Omega$ , $\tau < 100\text{ms}$	-50			V
eN	Output Noise Voltage	$B = 10\text{ Hz to }100\text{ KHz}$		330		$\mu\text{V}_{RMS}$

1. Reference Voltage is measured from  $V_{OUT}$  to ADJ pin.

2.  $V_d$  measured when the output voltage has dropped 100mV from the nominal value obtained at 14V.

## 6 Typical characteristics

(unless otherwise specified  $C_I = 0.1 \mu\text{F}$ ,  $C_O = 100 \mu\text{F}$ )

**Figure 5. Output voltage vs temperature**

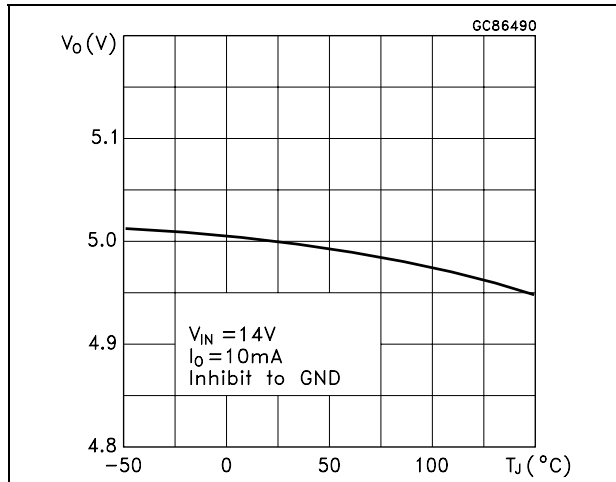

**Figure 6. Output voltage vs temperature**

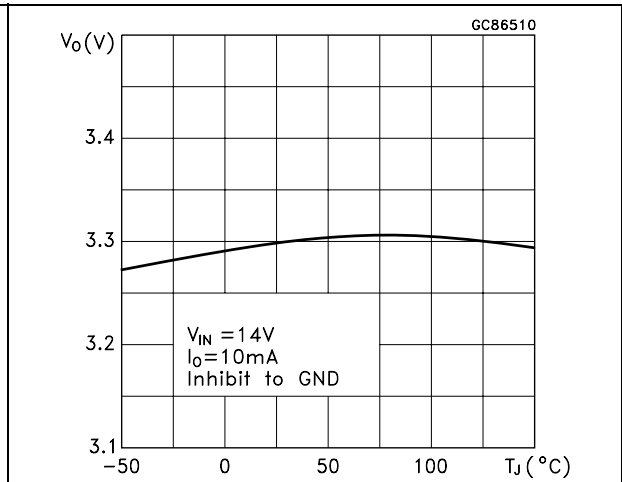

**Figure 7. Reference voltage vs temperature**

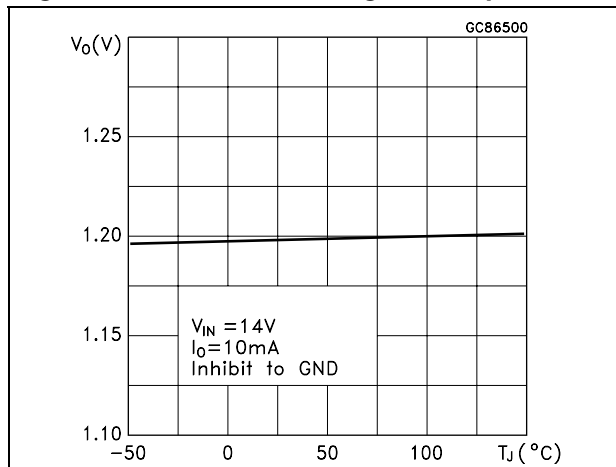

**Figure 8. Line regulation vs temperature**

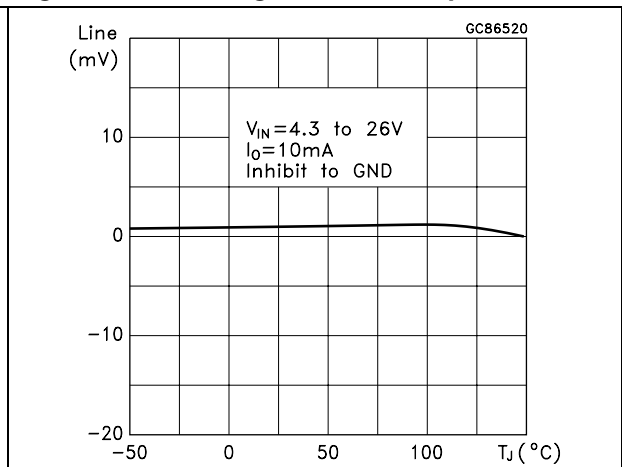

**Figure 9. Load regulation vs temperature**

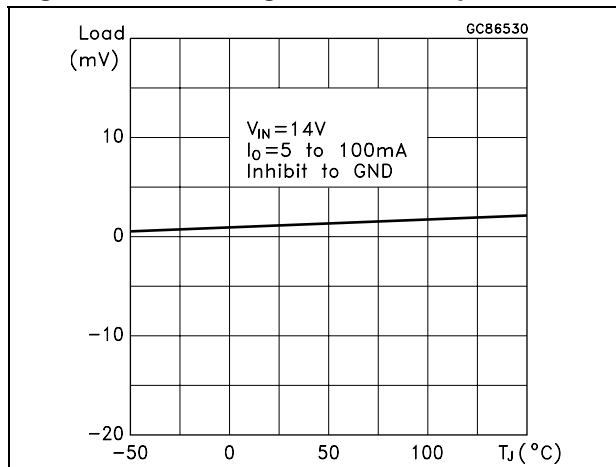

**Figure 10. Dropout voltage vs temperature**

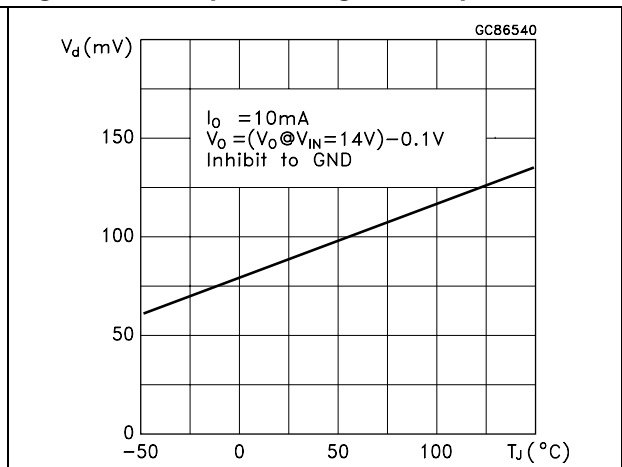

Figure 11. Dropout voltage vs temperature

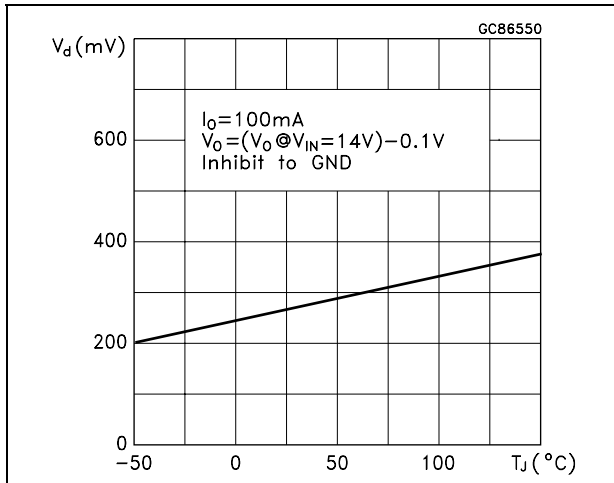

Figure 12. Dropout voltage vs output current

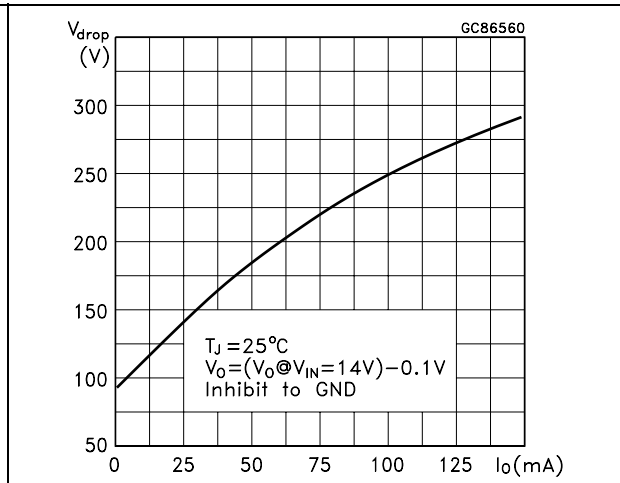

Figure 13. Output voltage vs input voltage

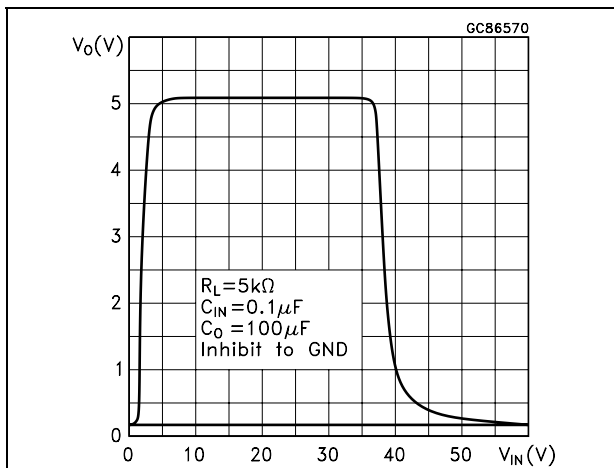

Figure 14. Short circuit current vs drop voltage

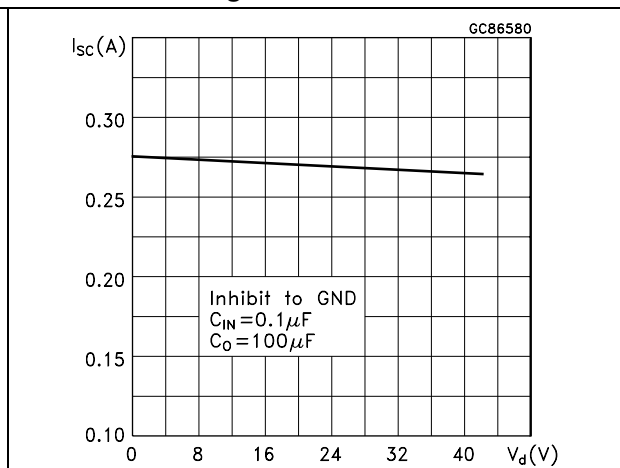

Figure 15. Quiescent current vs temperature

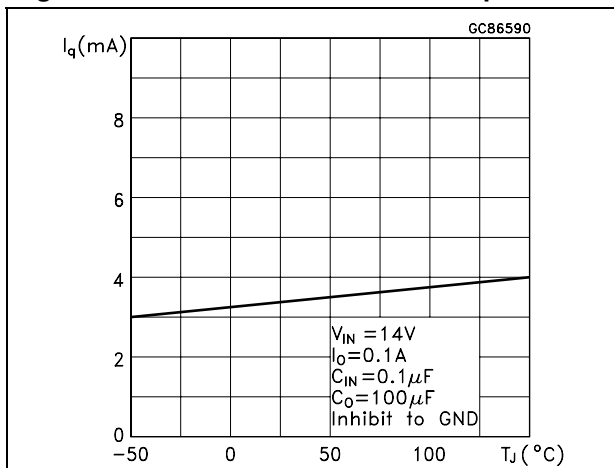

Figure 16. Quiescent current vs input voltage

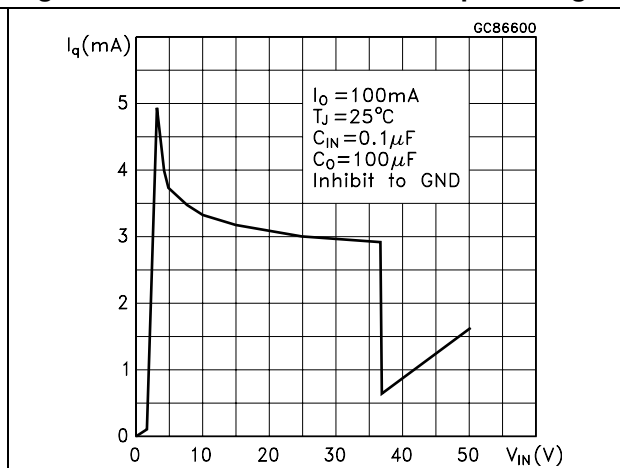

Figure 17. Quiescent current vs output current Figure 18. Supply voltage rejection vs temperature

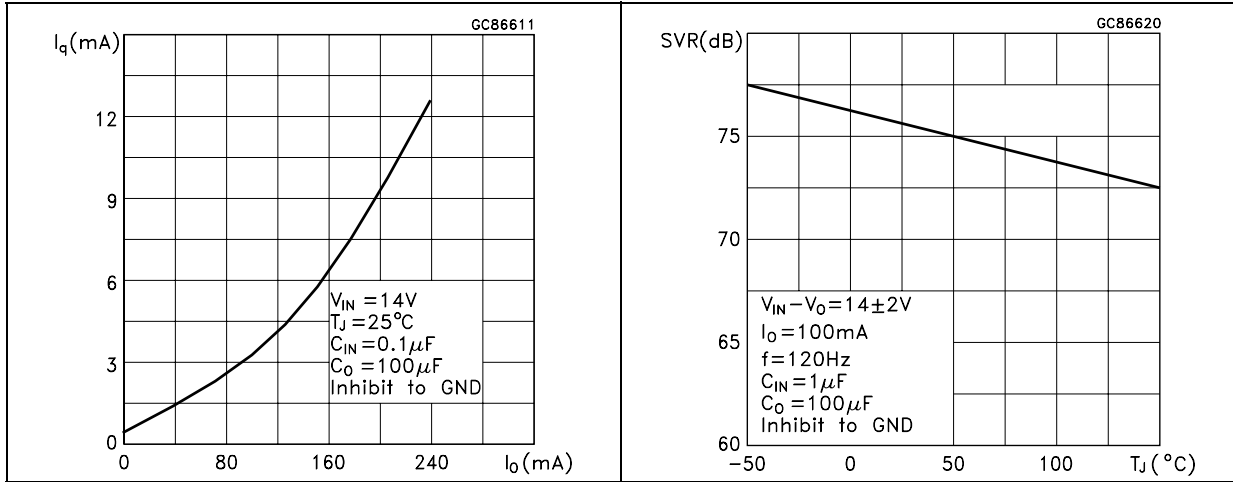

Figure 19. Supply voltage rejection vs frequency

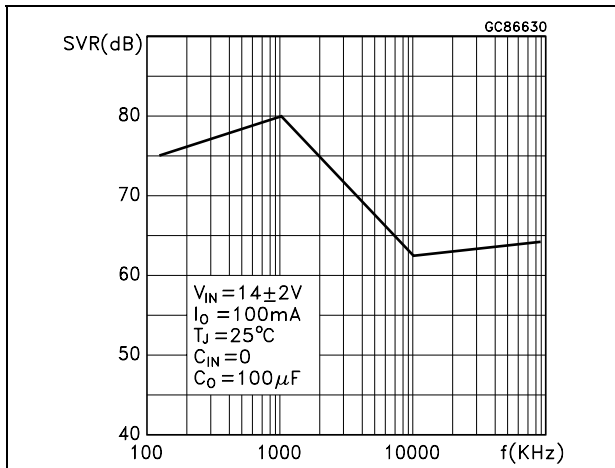

Figure 20. Supply voltage rejection vs output current

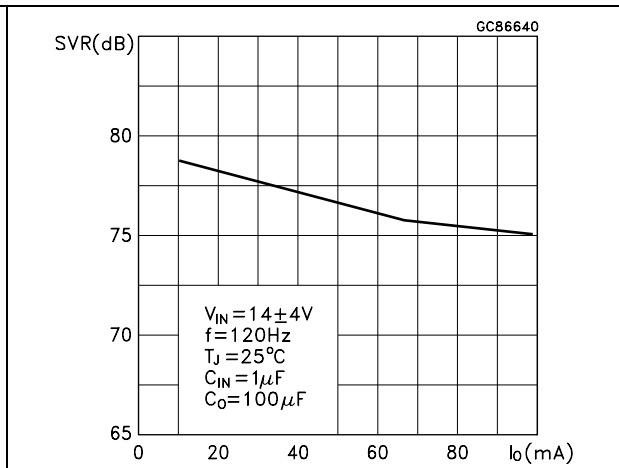

Figure 21. Stability vs  $C_O$

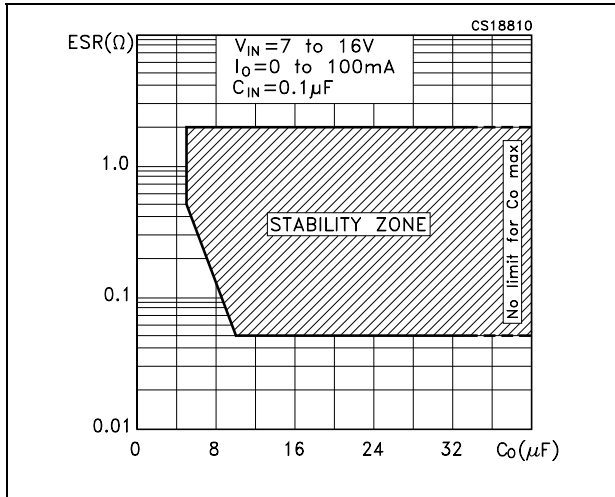

Figure 22. Line transient

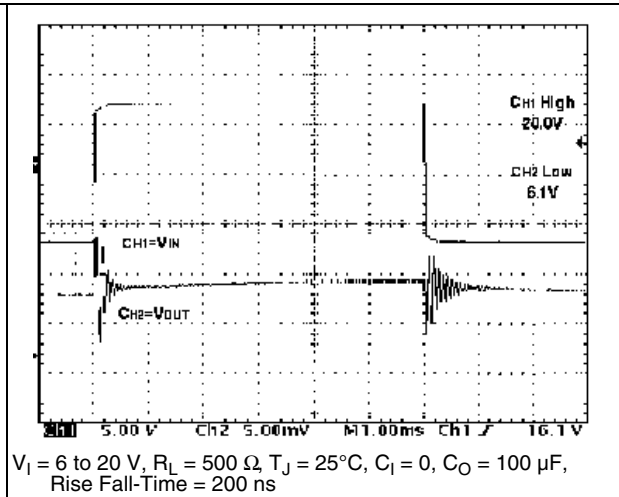
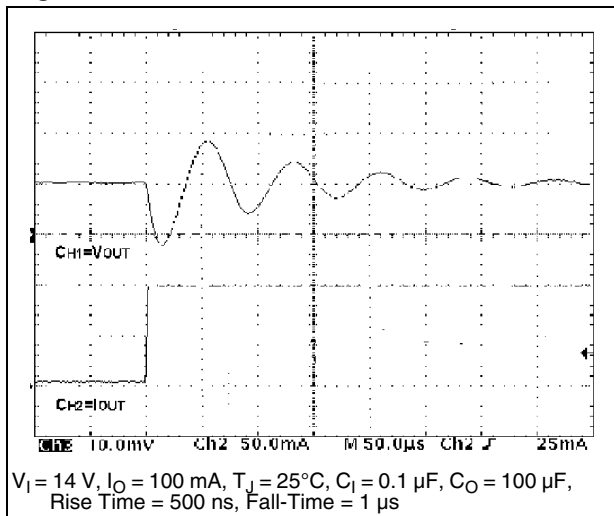

Figure 23. Line transient



## 7 Package mechanical data

In order to meet environmental requirements, ST offers these devices in ECOPACK<sup>®</sup> packages. These packages have a lead-free second level interconnect. The category of second Level Interconnect is marked on the package and on the inner box label, in compliance with JEDEC Standard JESD97. The maximum ratings related to soldering conditions are also marked on the inner box label. ECOPACK is an ST trademark. ECOPACK specifications are available at: [www.st.com](http://www.st.com).

**TO-220 mechanical data**

Dim.	mm.			inch.		
	Min.	Typ.	Max.	Min.	Typ.	Max.
A	4.40		4.60	0.173		0.181
C	1.23		1.32	0.048		0.051
D	2.40		2.72	0.094		0.107
D1		1.27			0.050	
E	0.49		0.70	0.019		0.027
F	0.61		0.88	0.024		0.034
F1	1.14		1.70	0.044		0.067
F2	1.14		1.70	0.044		0.067
G	4.95		5.15	0.194		0.203
G1	2.4		2.7	0.094		0.106
H2	10.0		10.40	0.393		0.409
L2		16.4			0.645	
L4	13.0		14.0	0.511		0.551
L5	2.65		2.95	0.104		0.116
L6	15.25		15.75	0.600		0.620
L7	6.2		6.6	0.244		0.260
L9	3.5		3.93	0.137		0.154
DIA.	3.75		3.85	0.147		0.151

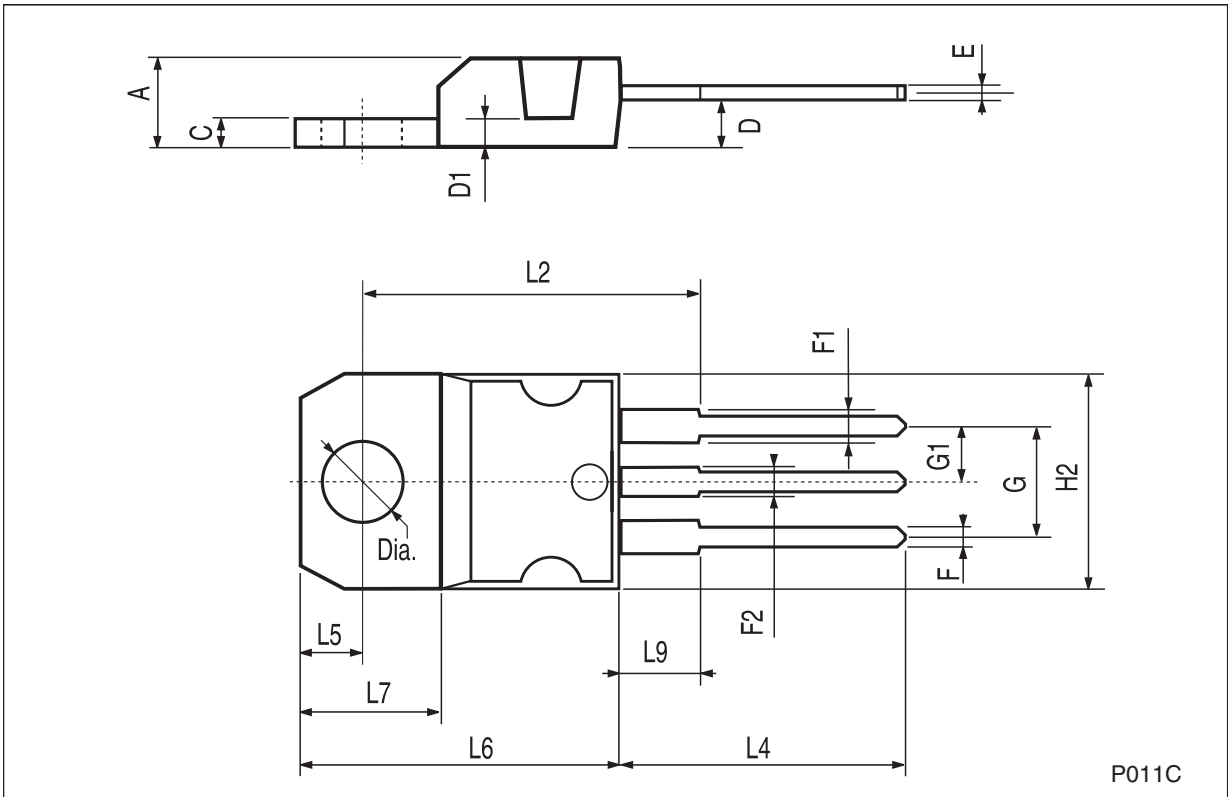

P011C

**TO-92 mechanical data**

Dim.	mm.			mils.		
	Min.	Typ.	Max.	Min.	Typ.	Max.
A	4.32		4.95	170.1		194.9
b	0.36		0.51	14.2		20.1
D	4.45		4.95	175.2		194.9
E	3.30		3.94	129.9		155.1
e	2.41		2.67	94.9		105.1
e1	1.14		1.40	44.9		55.1
L	12.7		15.49	500.0		609.8
R	2.16		2.41	85.0		94.9
S1	0.92		1.52	36.2		59.8
W	0.41		0.56	16.1		22.0
$\alpha$		5°			5°	

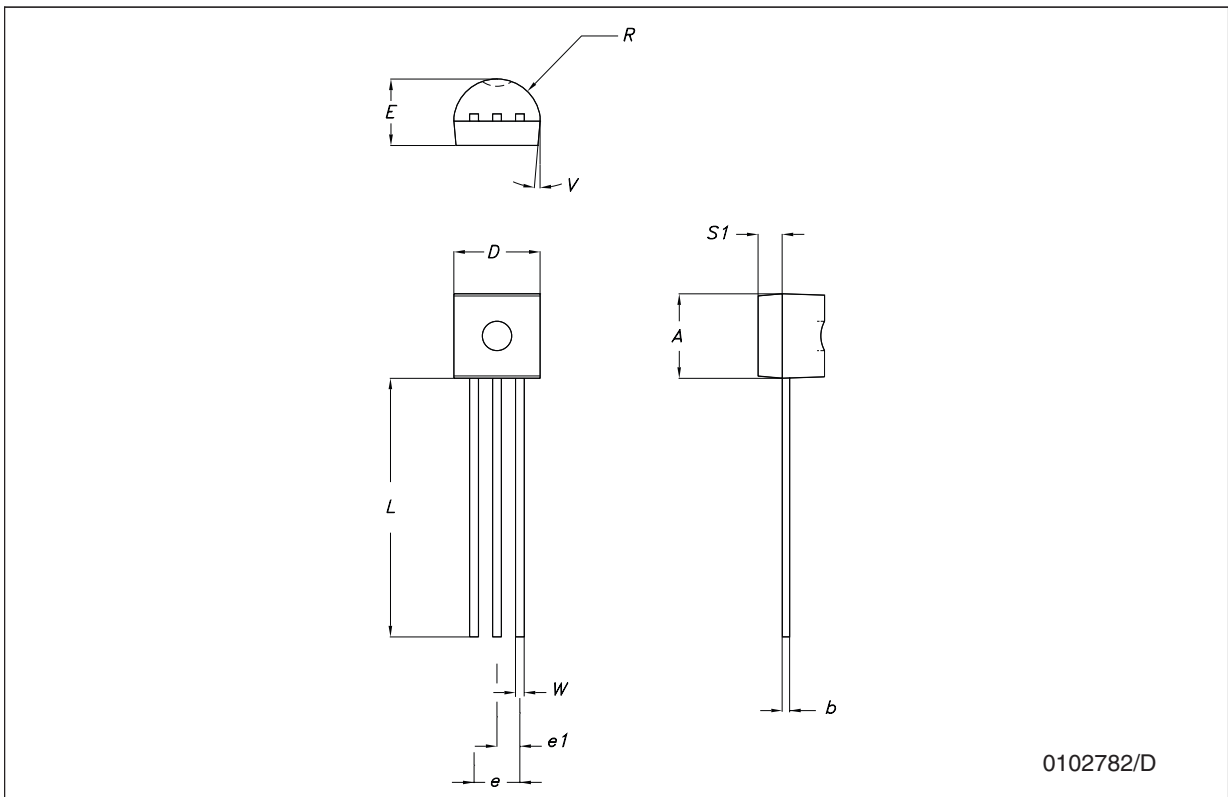

**DPAK mechanical data**

Dim.	mm.			inch.		
	Min.	Typ.	Max.	Min.	Typ.	Max.
A	2.2		2.4	0.086		0.094
A1	0.9		1.1	0.035		0.043
A2	0.03		0.23	0.001		0.009
B	0.64		0.9	0.025		0.035
b4	5.2		5.4	0.204		0.212
C	0.45		0.6	0.017		0.023
C2	0.48		0.6	0.019		0.023
D	6		6.2	0.236		0.244
D1		5.1			0.200	
E	6.4		6.6	0.252		0.260
E1		4.7			0.185	
e		2.28			0.090	
e1	4.4		4.6	0.173		0.181
H	9.35		10.1	0.368		0.397
L	1			0.039		
(L1)		2.8			0.110	
L2		0.8			0.031	
L4	0.6		1	0.023		0.039
R		0.2			0.008	
V2	0°		8°	0°		8°

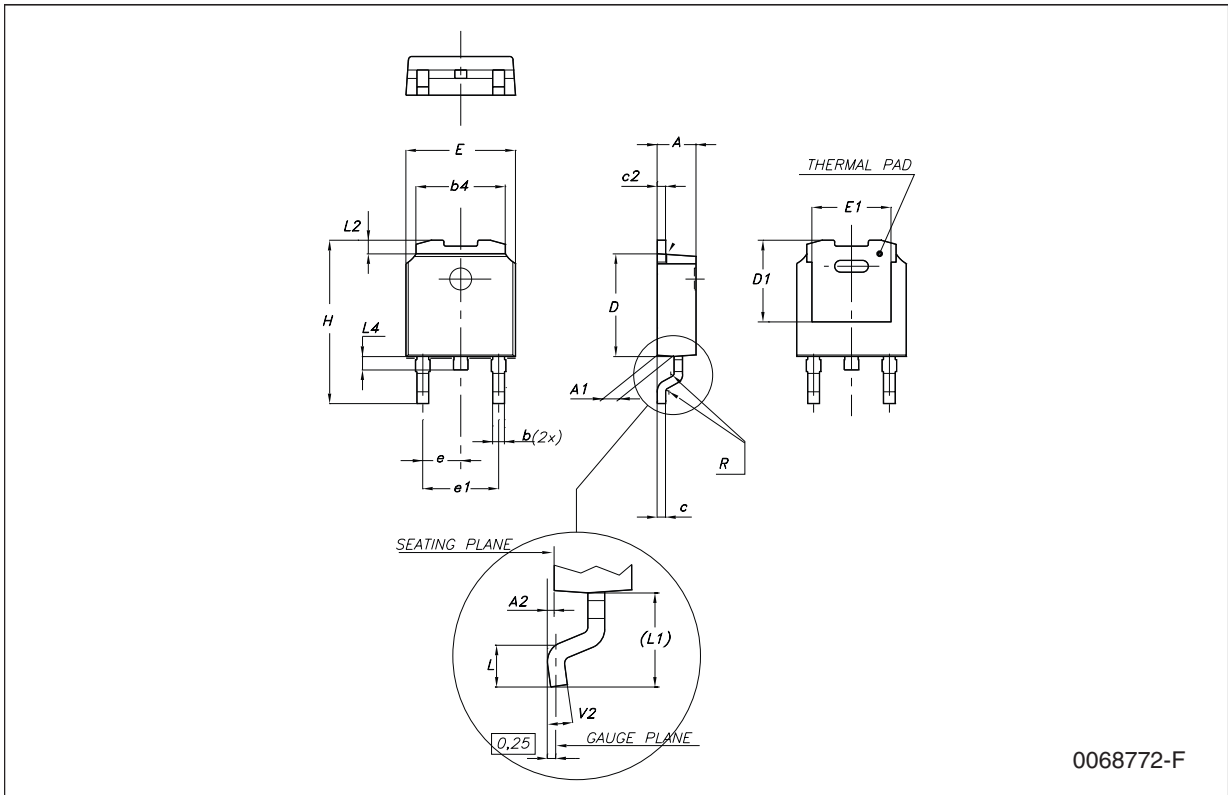

0068772-F

**SO-8 mechanical data**

Dim.	mm.			inch.		
	Min.	Typ.	Max.	Min.	Typ.	Max.
A	1.35		1.75	0.053		0.069
A1	0.10		0.25	0.04		0.010
A2	1.10		1.65	0.043		0.065
B	0.33		0.51	0.013		0.020
C	0.19		0.25	0.007		0.010
D	4.80		5.00	0.189		0.197
E	3.80		4.00	0.150		0.157
e		1.27			0.050	
H	5.80		6.20	0.228		0.244
h	0.25		0.50	0.010		0.020
L	0.40		1.27	0.016		0.050
k	8° (max.)					
ddd			0.1			0.04

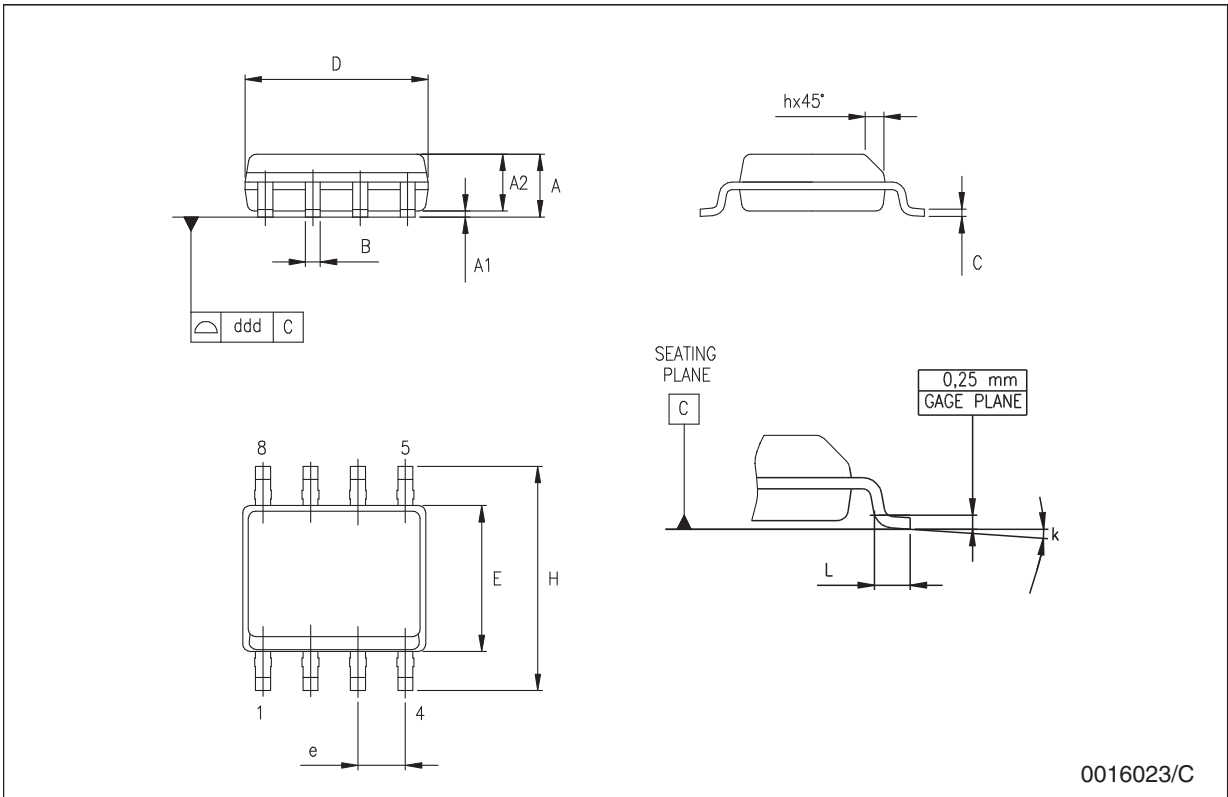

**Tape & reel DPAK-PPAK mechanical data**

Dim.	mm.			inch.		
	Min.	Typ.	Max.	Min.	Typ.	Max.
A			330			12.992
C	12.8	13.0	13.2	0.504	0.512	0.519
D	20.2			0.795		
N	60			2.362		
T			22.4			0.882
Ao	6.80	6.90	7.00	0.268	0.272	0.276
Bo	10.40	10.50	10.60	0.409	0.413	0.417
Ko	2.55	2.65	2.75	0.100	0.104	0.105
Po	3.9	4.0	4.1	0.153	0.157	0.161
P	7.9	8.0	8.1	0.311	0.315	0.319

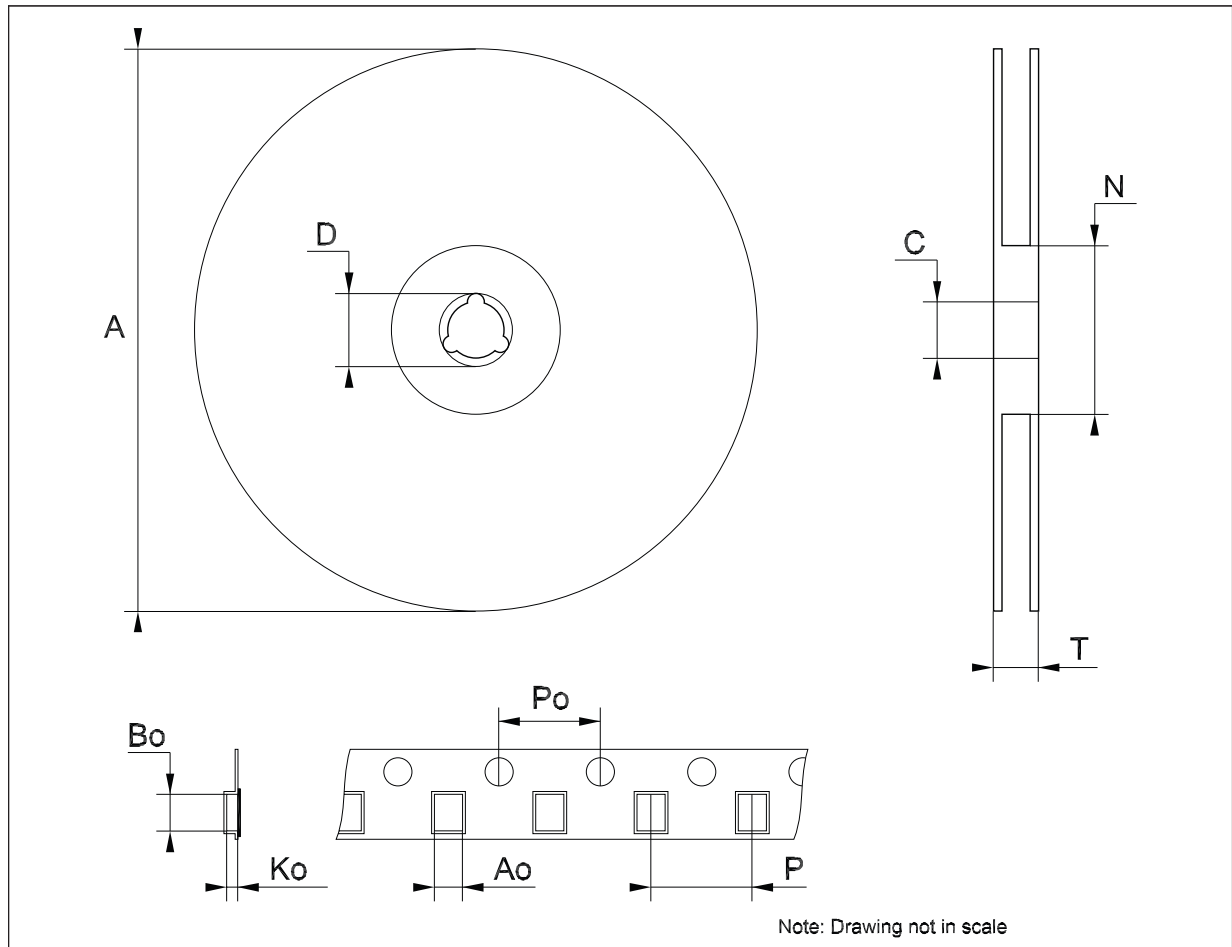

**Tape & reel SO-8 mechanical data**

Dim.	mm.			inch.		
	Min.	Typ.	Max.	Min.	Typ.	Max.
A			330			12.992
C	12.8		13.2	0.504		0.519
D	20.2			0.795		
N	60			2.362		
T			22.4			0.882
Ao	8.1		8.5	0.319		0.335
Bo	5.5		5.9	0.216		0.232
Ko	2.1		2.3	0.082		0.090
Po	3.9		4.1	0.153		0.161
P	7.9		8.1	0.311		0.319

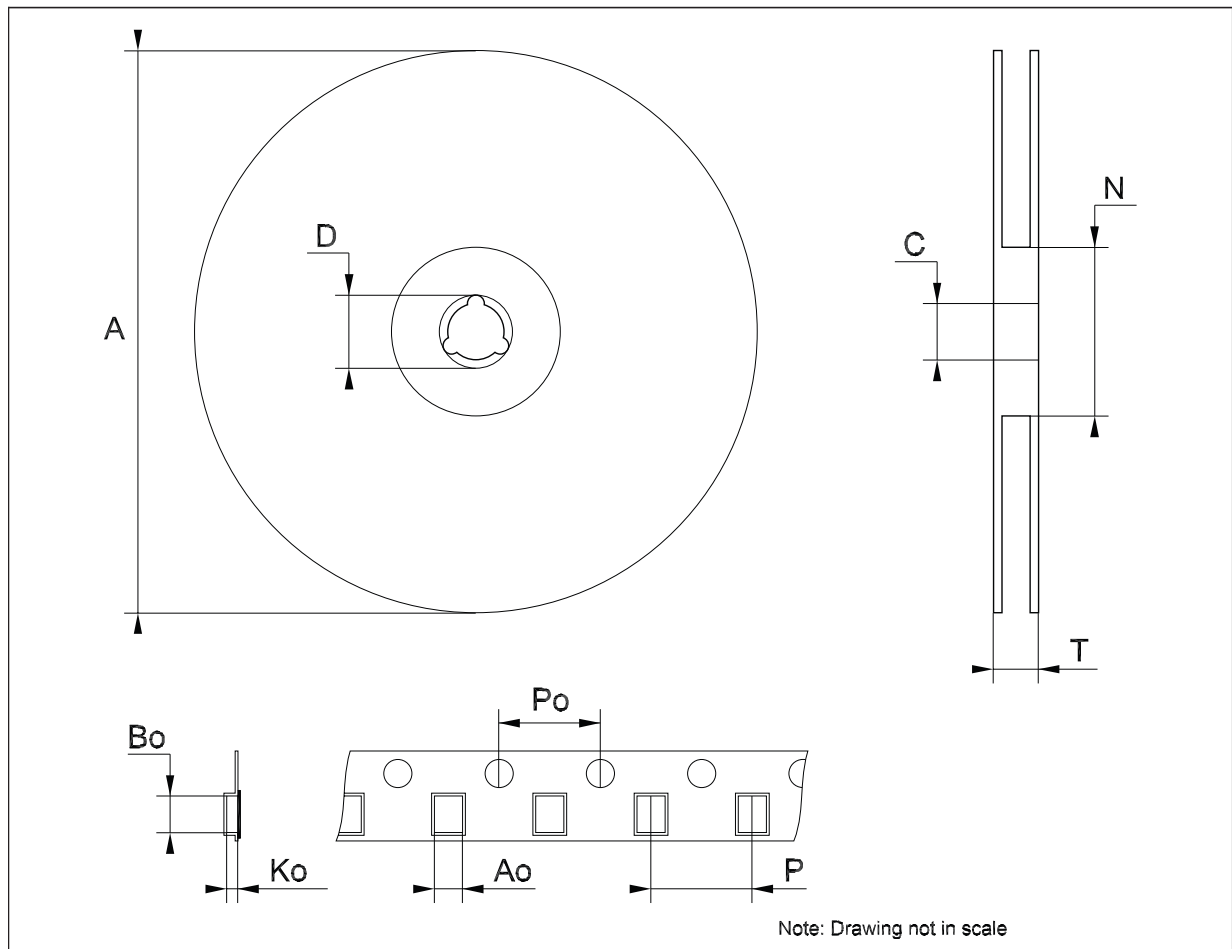

**Tape & reel for TO-92 mechanical data**

Dim.	mm.			inch.		
	Min.	Typ.	Max.	Min.	Typ.	Max.
A1		4.80			0.189	
T		3.80			0.150	
T1		1.60			0.063	
T2		2.30			0.091	
d		0.48			0.019	
P0	12.5		12.9	0.492		0.508
P2	5.65		7.05	0.222		0.278
F1, F2	2.44	2.54	2.94	0.096	0.100	0.116
delta H		±2			0.079	
W	17.5	18.00	19.0	0.689	0.709	0.748
W0	5.7		6.3	0.224		0.248
W1	8.5		9.25	0.335		0.364
W2		0.50			0.20	
H		18.50	18.70		0.728	0.726
H0	15.50		16.50	0.610		0.650
H1		25.00			0.984	
D0	3.8		4.2	0.150		0.165
t		0.90			0.035	
L1		3			0.118	
delta P		±1			0.039	
u		50			1.968	
Φ1		360			14.173	
Φ2		30			1.181	

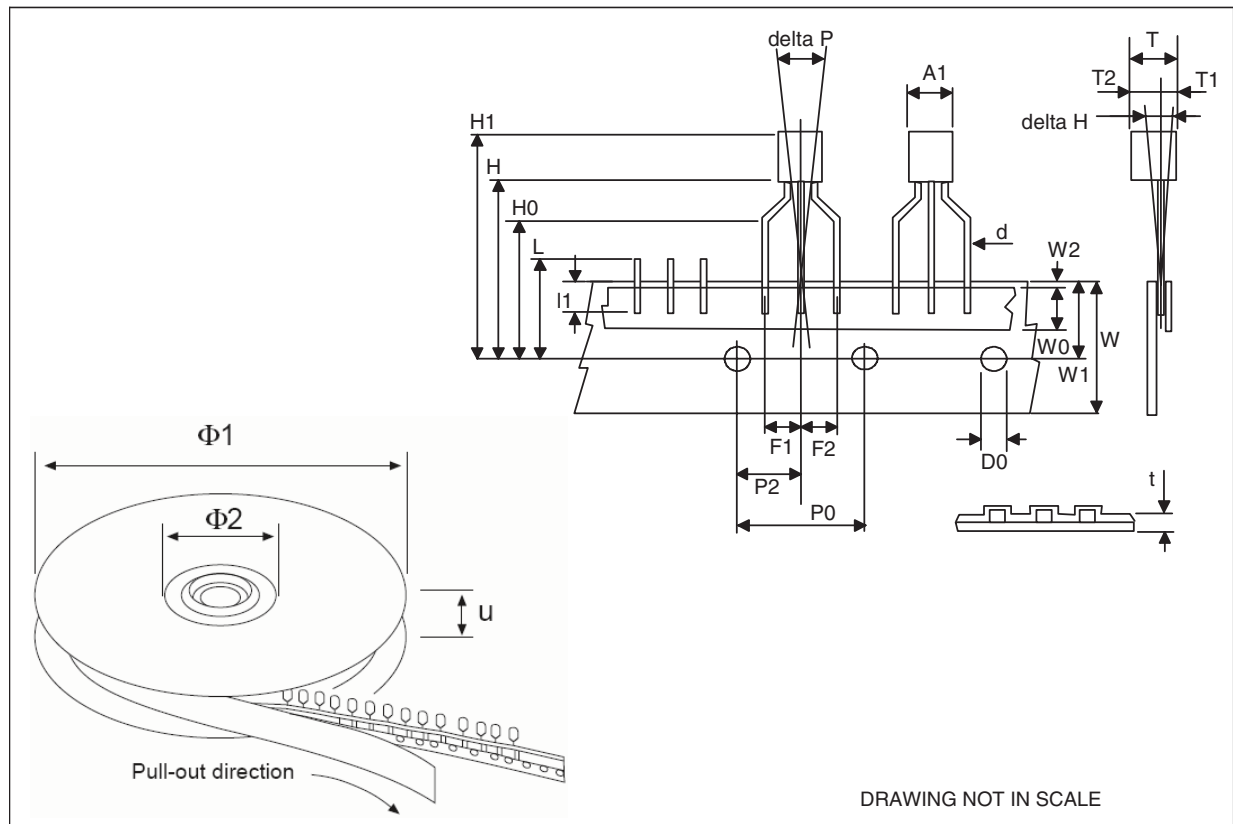

## 8 Revision history

**Table 8. Document revision history**

Date	Revision	Changes
21-Jun-2004	12	Document updated.
16-Jun-2006	13	Order codes updated.
27-Jul-2007	14	Add <a href="#">Table 1</a> in cover page.
21-Aug-2007	15	Added root part number - (see <a href="#">Table 1</a> )
22-Nov-2007	16	Modified: <a href="#">Table 1</a> .

**Please Read Carefully:**

Information in this document is provided solely in connection with ST products. STMicroelectronics NV and its subsidiaries ("ST") reserve the right to make changes, corrections, modifications or improvements, to this document, and the products and services described herein at any time, without notice.

All ST products are sold pursuant to ST's terms and conditions of sale.

Purchasers are solely responsible for the choice, selection and use of the ST products and services described herein, and ST assumes no liability whatsoever relating to the choice, selection or use of the ST products and services described herein.

No license, express or implied, by estoppel or otherwise, to any intellectual property rights is granted under this document. If any part of this document refers to any third party products or services it shall not be deemed a license grant by ST for the use of such third party products or services, or any intellectual property contained therein or considered as a warranty covering the use in any manner whatsoever of such third party products or services or any intellectual property contained therein.

**UNLESS OTHERWISE SET FORTH IN ST'S TERMS AND CONDITIONS OF SALE ST DISCLAIMS ANY EXPRESS OR IMPLIED WARRANTY WITH RESPECT TO THE USE AND/OR SALE OF ST PRODUCTS INCLUDING WITHOUT LIMITATION IMPLIED WARRANTIES OF MERCHANTABILITY, FITNESS FOR A PARTICULAR PURPOSE (AND THEIR EQUIVALENTS UNDER THE LAWS OF ANY JURISDICTION), OR INFRINGEMENT OF ANY PATENT, COPYRIGHT OR OTHER INTELLECTUAL PROPERTY RIGHT.**

**UNLESS EXPRESSLY APPROVED IN WRITING BY AN AUTHORIZED ST REPRESENTATIVE, ST PRODUCTS ARE NOT RECOMMENDED, AUTHORIZED OR WARRANTED FOR USE IN MILITARY, AIR CRAFT, SPACE, LIFE SAVING, OR LIFE SUSTAINING APPLICATIONS, NOR IN PRODUCTS OR SYSTEMS WHERE FAILURE OR MALFUNCTION MAY RESULT IN PERSONAL INJURY, DEATH, OR SEVERE PROPERTY OR ENVIRONMENTAL DAMAGE. ST PRODUCTS WHICH ARE NOT SPECIFIED AS "AUTOMOTIVE GRADE" MAY ONLY BE USED IN AUTOMOTIVE APPLICATIONS AT USER'S OWN RISK.**

Resale of ST products with provisions different from the statements and/or technical features set forth in this document shall immediately void any warranty granted by ST for the ST product or service described herein and shall not create or extend in any manner whatsoever, any liability of ST.

ST and the ST logo are trademarks or registered trademarks of ST in various countries.

Information in this document supersedes and replaces all information previously supplied.

The ST logo is a registered trademark of STMicroelectronics. All other names are the property of their respective owners.

© 2007 STMicroelectronics - All rights reserved

STMicroelectronics group of companies

Australia - Belgium - Brazil - Canada - China - Czech Republic - Finland - France - Germany - Hong Kong - India - Israel - Italy - Japan - Malaysia - Malta - Morocco - Singapore - Spain - Sweden - Switzerland - United Kingdom - United States of America

[www.st.com](http://www.st.com)