



# LPY410AL

## MEMS motion sensor: dual-axis pitch and yaw $\pm 100$ dps analog gyroscope

### Features

- 2.7 V to 3.6 V single-supply operation
- Wide operating temperature range (-40 °C to +85 °C)
- High stability over temperature
- Analog absolute angular-rate outputs
- Two separate outputs for each axis (1x and 4x amplified)
- Integrated low-pass filters
- Low power consumption
- Embedded power-down
- Embedded self-test
- Sleep mode
- High shock and vibration survivability
- ECOPACK<sup>®</sup> RoHS and “Green” compliant (see [Section 6](#))

### Applications

- GPS navigation systems
- Motion tracking
- Pointing devices, remote and game controllers
- Motion control with user interface
- Industrial and robotics

### Description

The LPY410AL is a low-power dual-axis micromachined gyroscope capable of measuring angular rate along pitch and yaw axes.

It provides excellent temperature stability and high resolution over an extended operating temperature range (-40 °C to +85 °C).

**Table 1. Device summary**

Order code	Temperature range (°C)	Package	Packing
LPY410AL	-40 to +85	LGA-28 (4x5x1)	Tray
LPY410ALTR	-40 to +85	LGA-28 (4x5x1)	Tape and reel

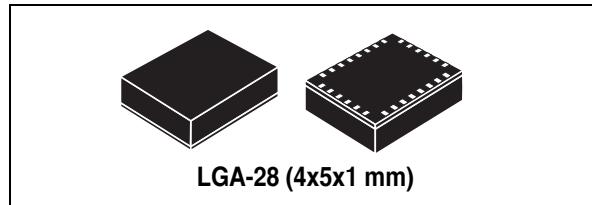

The LPY410AL has a full scale of  $\pm 100$  dps and is capable of detecting rates with a -3 dB bandwidth up to 560 Hz.

The device includes a sensing element composed of a single driving mass, kept in continuous oscillation and capable of reacting, based on the Coriolis principle, when an angular rate is applied.

A CMOS IC provides the measured angular rate to the external world through an analog output voltage, allowing high levels of integration and production trimming to better match sensing element characteristics.

ST's family of gyroscopes leverages on the mature and robust manufacturing process already used for the production of micro-machined accelerometers.

ST is already in the field with several hundred million sensors which have received excellent acceptance from the market in terms of quality, reliability and performance.

The LPY410AL is available in a plastic land grid array (LGA) package, which ST successfully pioneered for accelerometers. Today ST has the widest manufacturing capability and strongest expertise in the world for production of sensors in plastic LGA packages.

# Contents

- 1      Block diagram and pin description ..... 3**
  - 1.1    Pin description ..... 3
  
- 2      Mechanical and electrical specifications ..... 5**
  - 2.1    Mechanical characteristics ..... 5
  - 2.2    Electrical characteristics ..... 6
  
- 3      Absolute maximum ratings ..... 7**
  
- 4      Terminology ..... 8**
  - 4.1    Sensitivity ..... 8
  - 4.2    Zero-rate level ..... 8
  - 4.3    Self-test ..... 8
  - 4.4    High pass filter reset (HP) ..... 8
  - 4.5    Sleep mode, self-test and power-down ..... 8
  
- 5      Application hints ..... 10**
  - 5.1    Output response vs. rotation ..... 11
  - 5.2    Soldering information ..... 11
  
- 6      Package information ..... 12**
  
- 7      Revision history ..... 13**

# 1 Block diagram and pin description

Figure 1. Block diagram

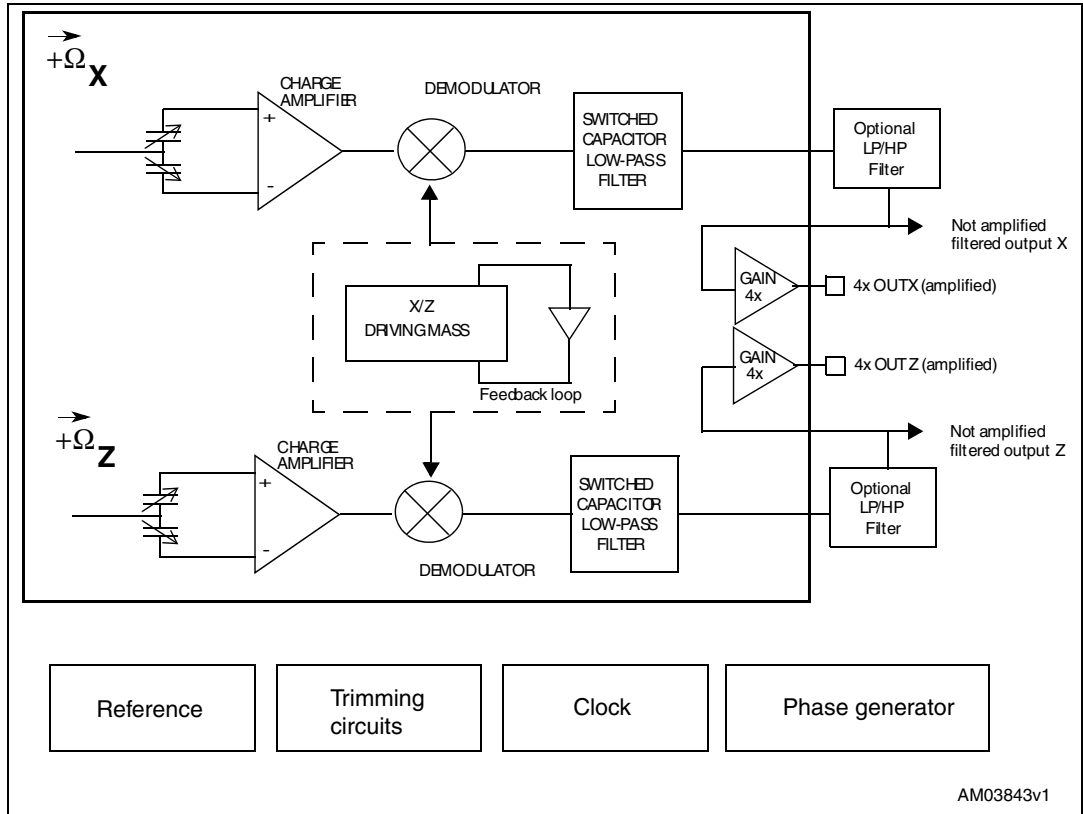

## 1.1 Pin description

Figure 2. Pin connection

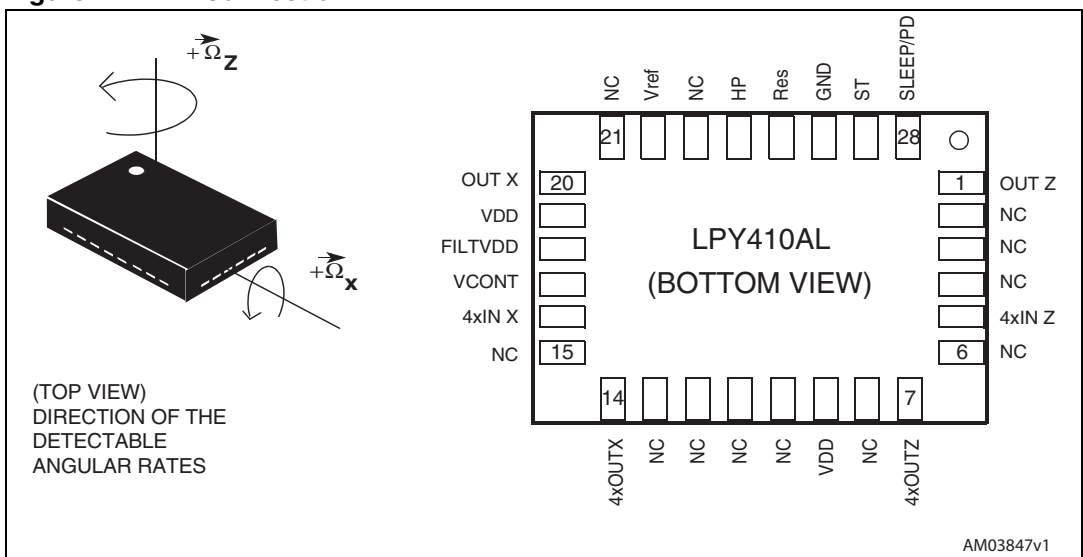

**Table 2. Pin description**

Pin #	Pin name	Analog function
1	OUT Z	Z rate signal output voltage (not amplified)
2	NC	Internally not connected
3	NC	Internally not connected
4	NC	Internally not connected
5	4xIN Z	Input of 4x amplifier
6	NC	Internally not connected
7	4xOUTZ	Z rate signal output voltage (amplified)
8	NC	Internally not connected
9	Vdd	Power supply
10	NC	Internally not connected
11	NC	Internally not connected
12	NC	Internally not connected
13	NC	Internally not connected
14	4xOUTX	X rate signal output voltage (amplified)
15	NC	Internally not connected
16	4xIN X	Input of 4x amplifier
17	VCONT	PLL filter connection pin #17
18	FILTVDD	PLL filter connection pin #18
19	Vdd	Reserved. connect to Vdd
20	OUTX	X rate signal output voltage (not amplified)
21	NC	Internally not connected
22	Vref	Reference voltage
23	NC	Internally not connected
24	HP	High-pass filter reset (logic 0: normal operation mode; logic1: external high-pass filter is reset)
25	Res	Reserved. Leave unconnected or connect to Vdd
26	GND	0V supply voltage
27	ST	Self-test (see <a href="#">Table 6</a> )
28	SLEEP/PD	Sleep mode / power-down mode (see <a href="#">Table 6</a> )

## 2 Mechanical and electrical specifications

### 2.1 Mechanical characteristics

V<sub>dd</sub> = 3 V, T = 25 °C unless otherwise noted<sup>(a)</sup>

**Table 3. Mechanical characteristics**

Symbol	Parameter	Test condition	Min.	Typ. <sup>(1)</sup>	Max.	Unit
FSA	Measurement range	4x OUT (amplified)		±100		dps
FS		OUT (not amplified)		±400		dps
SoA	Sensitivity <sup>(2)</sup>	4x OUT (amplified)		10		mV/dps
So		OUT (not amplified)		2.5		mV/dps
SoDr	Sensitivity change vs. temperature	Delta from 25°C		0.07		%/°C
Voff	Zero-rate level <sup>(3)</sup>			1.5		V
Vref	Reference voltage			1.5		V
OffDr	Zero-rate level change vs. temperature	Delta from 25°C		0.03		dps/°C
NL	Non linearity	Best fit straight line		±1		% FS
BW	Bandwidth <sup>(3)</sup>			560		Hz
Vst	Self-test output change			250 <sup>(4)</sup>		mV
Rn	Rate noise density			0.014		dps/√Hz
Top	Operating temperature range		-40		+85	°C

1. Typical specifications are not guaranteed.
2. Sensitivity and zero-rate level are not ratiometric to supply voltage.
3. The product is capable of measuring angular rates extending from DC to the selected BW.
4. Self test typical absolute value.

a. The product is factory calibrated at 3 V. The operational power supply range is specified in [Table 4](#).

## 2.2 Electrical characteristics

Vdd =3 V, T=25 °C unless otherwise noted<sup>(b)</sup>

**Table 4. Electrical characteristics**

Symbol	Parameter	Test condition	Min.	Typ. <sup>(1)</sup>	Max.	Unit
Vdd	Supply voltage		2.7	3	3.6	V
Idd	Supply current	SLEEP/PD pin connected to GND		6.8		mA
IddSI	Supply current sleep mode	SLEEP/PD, ST pin connected to Vdd		2.1		mA
IddPdn	Supply current in power-down mode	SLEEP/PD pin connected to Vdd		1	5	μA
VST	Self-test input	Logic 0 level	0		0.2*Vdd	V
		Logic 1 level	0.8*Vdd		Vdd	
VPD	Power-down input	Logic 0 level	0		0.2*Vdd	V
		Logic 1 level	0.8*Vdd		Vdd	
Top	Operating temperature range		-40		+85	°C

1. Typical specifications are not guaranteed.

b. The product is factory calibrated at 3 V

### 3 Absolute maximum ratings

Stresses above those listed as “Absolute maximum ratings” may cause permanent damage to the device. This is a stress rating only and functional operation of the device under these conditions is not implied. Exposure to maximum rating conditions for extended periods may affect device reliability.

**Table 5. Absolute maximum ratings**

Symbol	Ratings	Maximum value	Unit
Vdd	Supply voltage	-0.3 to 6	V
Vin	Input voltage on any control pin (SLEEP/PD, ST)	-0.3 to Vdd +0.3	V
T <sub>STG</sub>	Storage temperature range	-40 to +125	°C
A	Acceleration	3000 for 0.5 ms	<i>g</i>
		10000 for 0.1 ms	<i>g</i>
ESD	Electrostatic discharge protection	2 (HBM)	kV

 This is a mechanical shock sensitive device, improper handling can cause permanent damage to the part

 This is an ESD sensitive device, improper handling can cause permanent damage to the part

## 4 Terminology

### 4.1 Sensitivity

An angular rate gyroscope is a device that produces a positive-going output voltage for counterclockwise rotation around the sensitive axis considered. Sensitivity describes the gain of the sensor and can be determined by applying a defined angular velocity to it. This value changes very little over temperature and time.

### 4.2 Zero-rate level

Zero-rate level describes the actual output signal if there is no angular rate present. The zero-rate level of precise MEMS sensors is, to some extent, a result of stress to the sensor and therefore zero-rate level can slightly change after mounting the sensor onto a printed circuit board or after exposing it to extensive mechanical stress. This value changes very little over temperature and time.

### 4.3 Self-test

Self-test allows testing of the mechanical and electrical part of the sensor, allowing the seismic mass to be moved by means of an electrostatic test-force. The self-test function is off when the ST pin is connected to GND. When the ST pin is tied to Vdd, an actuation force is applied to the sensor, emulating a definite Coriolis force. In this case the sensor output exhibits a voltage change in its DC level which is also dependent on the supply voltage. When ST is active, the device output level is given by the algebraic sum of the signals produced by the velocity acting on the sensor and by the electrostatic test-force. If the output signals change within the amplitude specified in [Table 3](#), then the mechanical element is working properly and the parameters of the interface chip are within the defined specifications.

### 4.4 High pass filter reset (HP)

The LPY410AL provides the possibility to reset the optional external high-pass filter by applying a high logic value to the HP pad. This procedure ensures faster response, especially during overload conditions. Moreover, this operation is recommended each time the device is powered.

### 4.5 Sleep mode, self-test and power-down

The LPY410AL enables advanced power-saving features thanks to the availability of three different operating modes. When the device is set in a Sleep mode configuration, the reading chain is completely turned off, resulting in low power consumption. In this condition the device turn-on time is significantly reduced, allowing simple external power cycling.

In accordance with the table below, the user can select the desired operating mode using two dedicated pins (ST and SLEEP/PD).

**Table 6. Sleep-mode and Power-down mode configuration**

<b>Operating mode</b>	<b>ST pin</b>	<b>SLEEP/PD pin</b>
Normal mode	0	0
Power-down	0	1
Self-test	1	0
Sleep mode	1	1

## 5 Application hints

**Figure 3. LPY410AL electrical connections and external components values**

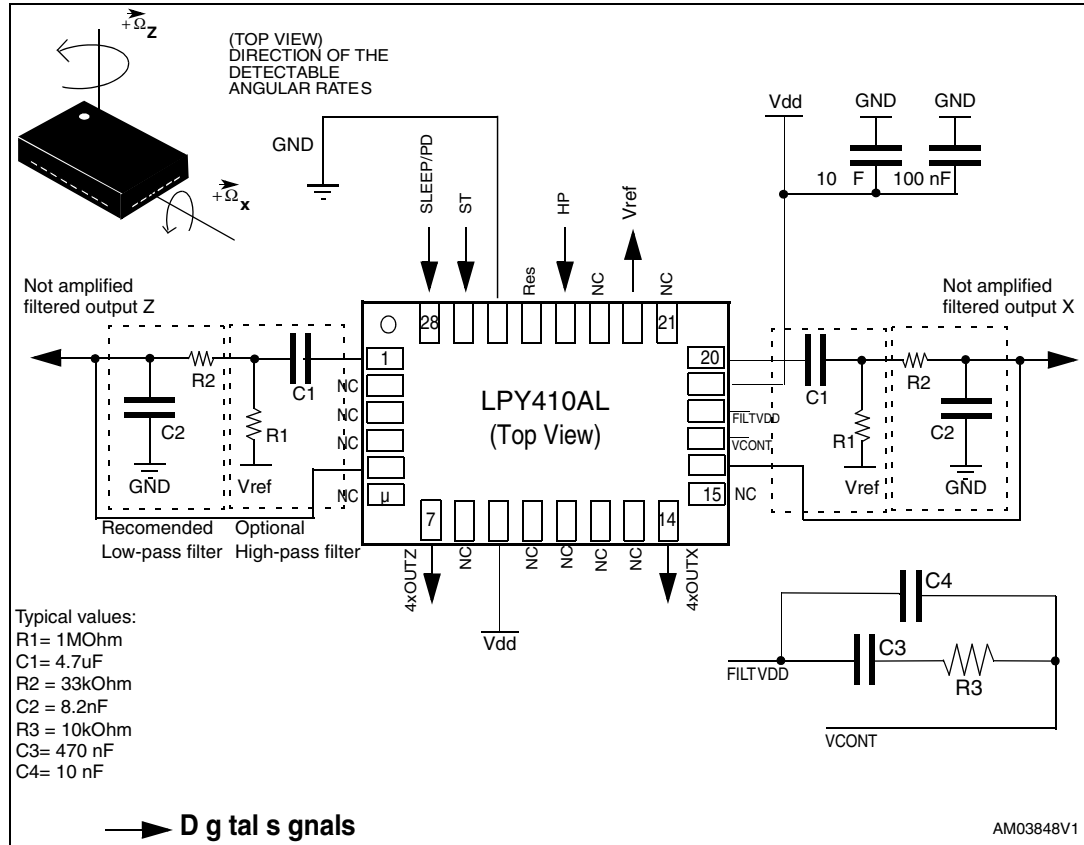

Power supply decoupling capacitors (100 nF ceramic or polyester + 10 μF aluminum) should be placed as near as possible to the device (common design practice).

The LPY410AL allows band limiting of the output rate response through the use of an external low-pass filter (recommended) in addition to the embedded low-pass filter ( $f_t = 560$  Hz).

The 4xOUTX and 4xOUTZ are, respectively, OUTX and OUTZ amplified output lines, internally buffered to ensure low output impedance.

If external low-pass filtering is not applied, it is mandatory to short-circuit pin 1 to pin 5 and pin 16 to pin 20, respectively, when amplified outputs are used.

When only a non-amplified output is used (OUTX/OUTZ), it is recommended to set pin 5 and 16 to a fixed reference voltage (Vref).

The LPY410AL IC includes a PLL (phase-locked loop) circuit to synchronize driving and sensing interfaces. Capacitors and resistors must be added at the **FILTVDD** and **VCONT** pins (as shown in [Figure 3](#)) to implement a low-pass filter.

## 5.1 Output response vs. rotation

Figure 4. Output response vs. rotation

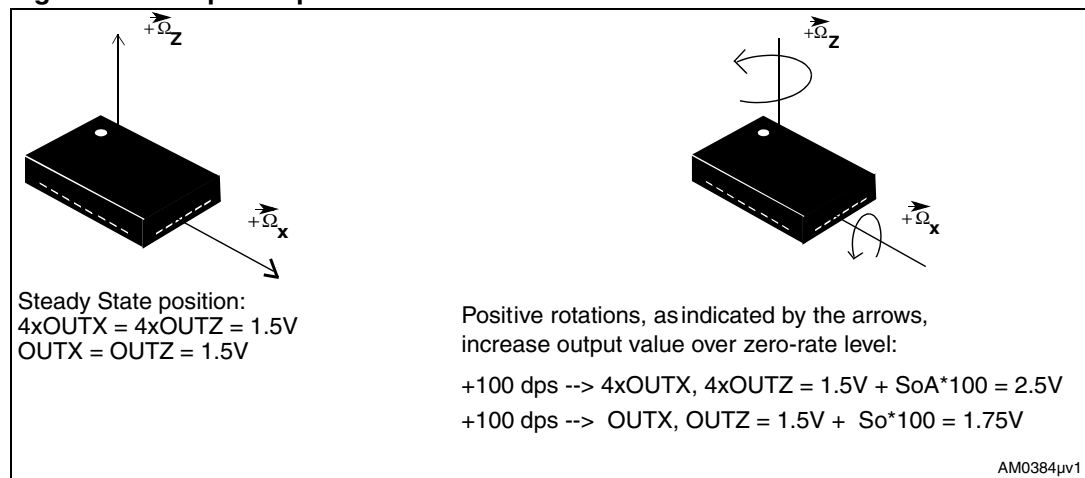

## 5.2 Soldering information

The LGA package is compliant with the ECOPACK<sup>®</sup>, RoHS and “Green” standards. It is qualified for soldering heat resistance in accordance with JEDEC J-STD-020.

Leave “pin 1 indicator” unconnected during soldering.

Land pattern and soldering recommendations are available at [www.st.com](http://www.st.com)

# 6 Package information

In order to meet environmental requirements, ST offers these devices in different grades of ECOPACK® packages, depending on their level of environmental compliance. ECOPACK® specifications, grade definitions and product status are available at: [www.st.com](http://www.st.com). ECOPACK is an ST trademark.

**Figure 5. LGA-28: mechanical data and package dimensions**

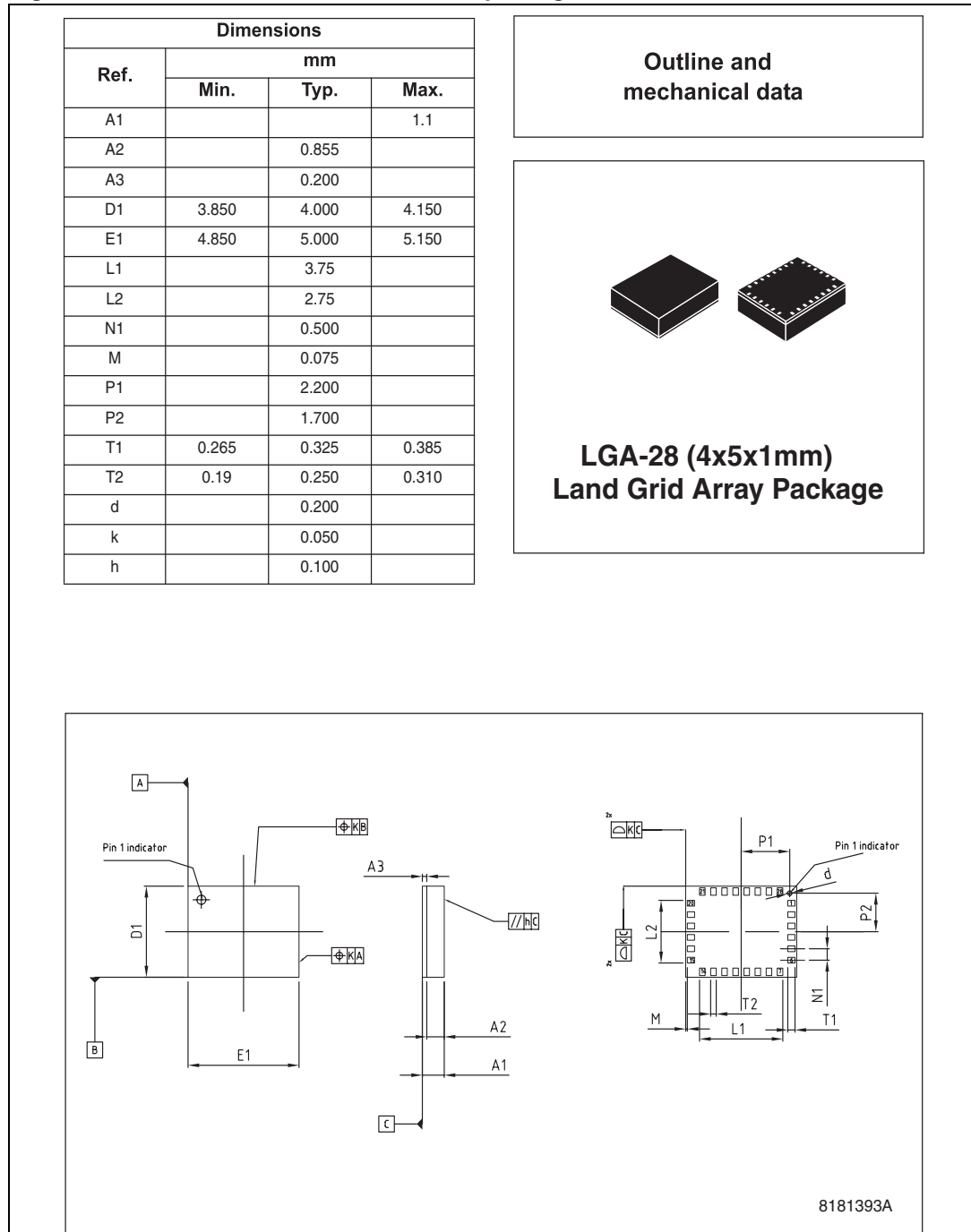

## 7 Revision history

**Table 7. Document revision history**

Date	Revision	Changes
29-Oct-2009	1	Initial release

**Please Read Carefully:**

Information in this document is provided solely in connection with ST products. STMicroelectronics NV and its subsidiaries ("ST") reserve the right to make changes, corrections, modifications or improvements, to this document, and the products and services described herein at any time, without notice.

All ST products are sold pursuant to ST's terms and conditions of sale.

Purchasers are solely responsible for the choice, selection and use of the ST products and services described herein, and ST assumes no liability whatsoever relating to the choice, selection or use of the ST products and services described herein.

No license, express or implied, by estoppel or otherwise, to any intellectual property rights is granted under this document. If any part of this document refers to any third party products or services it shall not be deemed a license grant by ST for the use of such third party products or services, or any intellectual property contained therein or considered as a warranty covering the use in any manner whatsoever of such third party products or services or any intellectual property contained therein.

**UNLESS OTHERWISE SET FORTH IN ST'S TERMS AND CONDITIONS OF SALE ST DISCLAIMS ANY EXPRESS OR IMPLIED WARRANTY WITH RESPECT TO THE USE AND/OR SALE OF ST PRODUCTS INCLUDING WITHOUT LIMITATION IMPLIED WARRANTIES OF MERCHANTABILITY, FITNESS FOR A PARTICULAR PURPOSE (AND THEIR EQUIVALENTS UNDER THE LAWS OF ANY JURISDICTION), OR INFRINGEMENT OF ANY PATENT, COPYRIGHT OR OTHER INTELLECTUAL PROPERTY RIGHT.**

**UNLESS EXPRESSLY APPROVED IN WRITING BY AN AUTHORIZED ST REPRESENTATIVE, ST PRODUCTS ARE NOT RECOMMENDED, AUTHORIZED OR WARRANTED FOR USE IN MILITARY, AIR CRAFT, SPACE, LIFE SAVING, OR LIFE SUSTAINING APPLICATIONS, NOR IN PRODUCTS OR SYSTEMS WHERE FAILURE OR MALFUNCTION MAY RESULT IN PERSONAL INJURY, DEATH, OR SEVERE PROPERTY OR ENVIRONMENTAL DAMAGE. ST PRODUCTS WHICH ARE NOT SPECIFIED AS "AUTOMOTIVE GRADE" MAY ONLY BE USED IN AUTOMOTIVE APPLICATIONS AT USER'S OWN RISK.**

Resale of ST products with provisions different from the statements and/or technical features set forth in this document shall immediately void any warranty granted by ST for the ST product or service described herein and shall not create or extend in any manner whatsoever, any liability of ST.

ST and the ST logo are trademarks or registered trademarks of ST in various countries.

Information in this document supersedes and replaces all information previously supplied.

The ST logo is a registered trademark of STMicroelectronics. All other names are the property of their respective owners.

© 2009 STMicroelectronics - All rights reserved

STMicroelectronics group of companies

Australia - Belgium - Brazil - Canada - China - Czech Republic - Finland - France - Germany - Hong Kong - India - Israel - Italy - Japan - Malaysia - Malta - Morocco - Philippines - Singapore - Spain - Sweden - Switzerland - United Kingdom - United States of America

[www.st.com](http://www.st.com)