

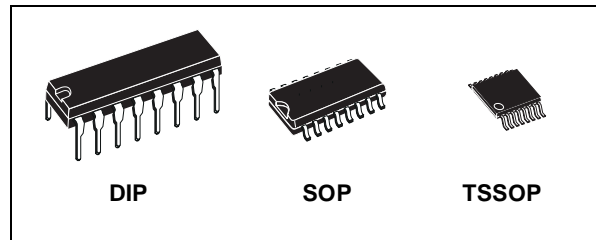

M74HC4050

HEX BUFFER/CONVERTER

- HIGH SPEED:
 $t_{PD} = 8\text{ns}$ (TYP.) at $V_{CC} = 6\text{V}$
- LOW POWER DISSIPATION:
 $I_{CC} = 1\mu\text{A}$ (MAX.) at $T_A = 25^\circ\text{C}$
- HIGH NOISE IMMUNITY:
 $V_{NIH} = V_{NIL} = 28\% V_{CC}$ (MIN.)
- SYMMETRICAL OUTPUT IMPEDANCE:
 $|I_{OH}| = I_{OL} = 6\text{mA}$ (MIN)
- BALANCED PROPAGATION DELAYS:
 $t_{PLH} \approx t_{PHL}$
- WIDE OPERATING VOLTAGE RANGE:
 V_{CC} (OPR) = 2V to 6V
- PIN AND FUNCTION COMPATIBLE WITH
 74 SERIES 4050



ORDER CODES

PACKAGE	TUBE	T & R
DIP	M74HC4050B1R	
SOP	M74HC4050M1R	M74HC4050RM13TR
TSSOP		M74HC4050TTR

DESCRIPTION

The M74HC4049 is an high speed CMOS HEX BUFFER fabricated with silicon gate C²MOS technology.

The internal circuit is composed of 3 stages, which enables high noise immunity and a stable output.

Input protection circuits are different from those of the high speed CMOS IC's.

The V_{cc} side diodes are designed to allow logic-level conversion from high-level voltages (up to 13V) to low level voltages.

PIN CONNECTION AND IEC LOGIC SYMBOLS

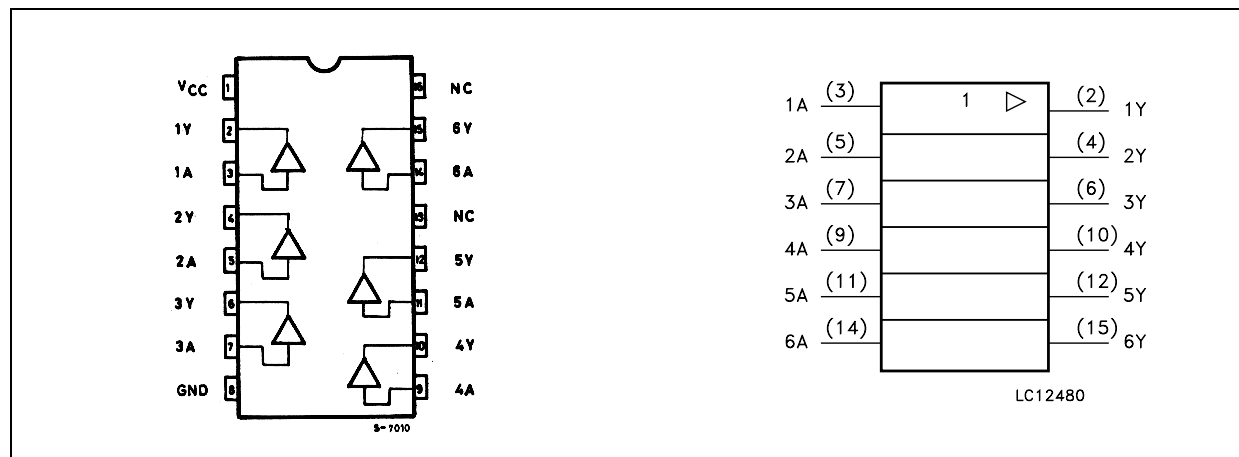

INPUT AND OUTPUT EQUIVALENT CIRCUIT

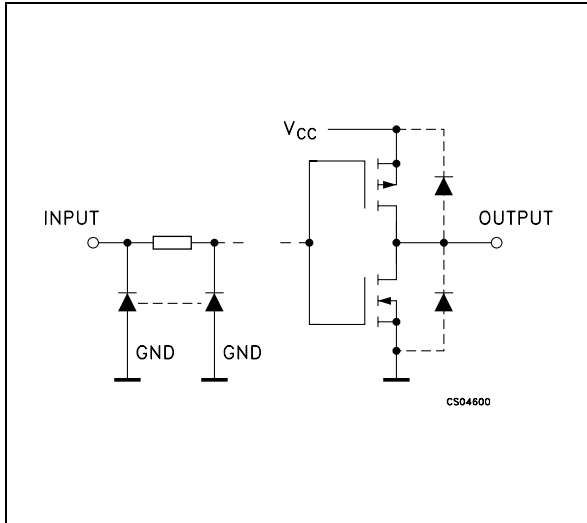

PIN DESCRIPTION

PIN No	SYMBOL	NAME AND FUNCTION
2, 4, 6, 10, 12, 15	1Y to 6Y	Data Outputs
3, 5, 7, 9, 11, 14	1A to 6A	Data Inputs
13, 16	NC	Not Connected
8	GND	Ground (0V)
1	V _{CC}	Positive Supply Voltage

TRUTH TABLE

INPUT	OUTPUT
nA	nY
L	L
H	H

ABSOLUTE MAXIMUM RATINGS

Symbol	Parameter	Value	Unit
V _{CC}	Supply Voltage	-0.5 to +7	V
V _I	DC Input Voltage	-0.5 to 15	V
V _O	DC Output Voltage	-0.5 to V _{CC} + 0.5	V
I _{IK}	DC Input Diode Current	- 20	mA
I _{OK}	DC Output Diode Current	± 20	mA
I _O	DC Output Current	± 25	mA
I _{CC} or I _{GND}	DC V _{CC} or Ground Current	± 50	mA
P _D	Power Dissipation	500(*)	mW
T _{stg}	Storage Temperature	-65 to +150	°C
T _L	Lead Temperature (10 sec)	300	°C

Absolute Maximum Ratings are those values beyond which damage to the device may occur. Functional operation under these conditions is not implied
 (*) 500mW at 65 °C; derate to 300mW by 10mW/°C from 65°C to 85°C

RECOMMENDED OPERATING CONDITIONS

Symbol	Parameter	Value	Unit	
V _{CC}	Supply Voltage	2 to 6	V	
V _I	Input Voltage	0 to 13	V	
V _O	Output Voltage	0 to V _{CC}	V	
T _{op}	Operating Temperature	-55 to 125	°C	
t _r , t _f	Input Rise and Fall Time	V _{CC} = 2.0V	0 to 1000	ns
		V _{CC} = 4.5V	0 to 500	ns
		V _{CC} = 6.0V	0 to 400	ns

DC SPECIFICATIONS

Symbol	Parameter	Test Condition		Value						Unit	
		V _{CC} (V)		T _A = 25°C			-40 to 85°C		-55 to 125°C		
				Min.	Typ.	Max.	Min.	Max.	Min.		Max.
V _{IH}	High Level Input Voltage	2.0		1.5			1.5		1.5		V
		4.5		3.15			3.15		3.15		
		6.0		4.2			4.2		4.2		
V _{IL}	Low Level Input Voltage	2.0				0.5		0.5		0.5	V
		4.5				1.35		1.35		1.35	
		6.0				1.8		1.8		1.8	
V _{OH}	High Level Output Voltage	2.0	I _O =-20 μA	1.9	2.0		1.9		1.9		V
		4.5	I _O =-20 μA	4.4	4.5		4.4		4.4		
		6.0	I _O =-20 μA	5.9	6.0		5.9		5.9		
		4.5	I _O =-4.0 mA	4.18	4.31		4.13		4.10		
		6.0	I _O =-5.2 mA	5.68	5.8		5.63		5.60		
V _{OL}	Low Level Output Voltage	2.0	I _O =20 μA		0.0	0.1		0.1		0.1	V
		4.5	I _O =20 μA		0.0	0.1		0.1		0.1	
		6.0	I _O =20 μA		0.0	0.1		0.1		0.1	
		4.5	I _O =4.0 mA		0.17	0.26		0.33		0.40	
		6.0	I _O =5.2 mA		0.18	0.26		0.33		0.40	
I _I	Input Leakage Current	6.0	V _I = V _{CC} or GND V _I = 13 V			± 0.1 ± 0.5		± 1 ± 5		± 1	μA
I _{CC}	Quiescent Supply Current	6.0	V _I = V _{CC} or GND			1		10		20	μA

AC ELECTRICAL CHARACTERISTICS (C_L = 50 pF, Input t_r = t_f = 6ns)

Symbol	Parameter	Test Condition		Value						Unit	
		V _{CC} (V)	C _L (pF)	T _A = 25°C			-40 to 85°C		-55 to 125°C		
				Min.	Typ.	Max.	Min.	Max.	Min.		Max.
t _{TLH} t _{THL}	Output Transition Time	2.0	50		25	60		75		90	ns
		4.5		7	12		15		18		
		6.0		6	10		13		15		
t _{PLH} t _{PHL}	Propagation Delay Time	2.0	50		30	75		95		115	ns
		4.5		9	15		19		23		
		6.0		8	13		16		20		
		2.0	150		45	100		125		150	
		4.5		14	20		25		30		
		6.0		12	17		21		26		

CAPACITIVE CHARACTERISTICS

Symbol	Parameter	Test Condition		Value						Unit	
		V _{CC} (V)		T _A = 25°C			-40 to 85°C		-55 to 125°C		
				Min.	Typ.	Max.	Min.	Max.	Min.		Max.
C _{IN}	Input Capacitance	5.0			5	10		10		10	pF
C _{PD}	Power Dissipation Capacitance (note 1)	5.0			26						pF

1) C_{PD} is defined as the value of the IC's internal equivalent capacitance which is calculated from the operating current consumption without load. (Refer to Test Circuit). Average operating current can be obtained by the following equation. I_{CC(oper)} = C_{PD} × V_{CC} × f_{IN} + I_{CC}/6 (per gate)

TEST CIRCUIT

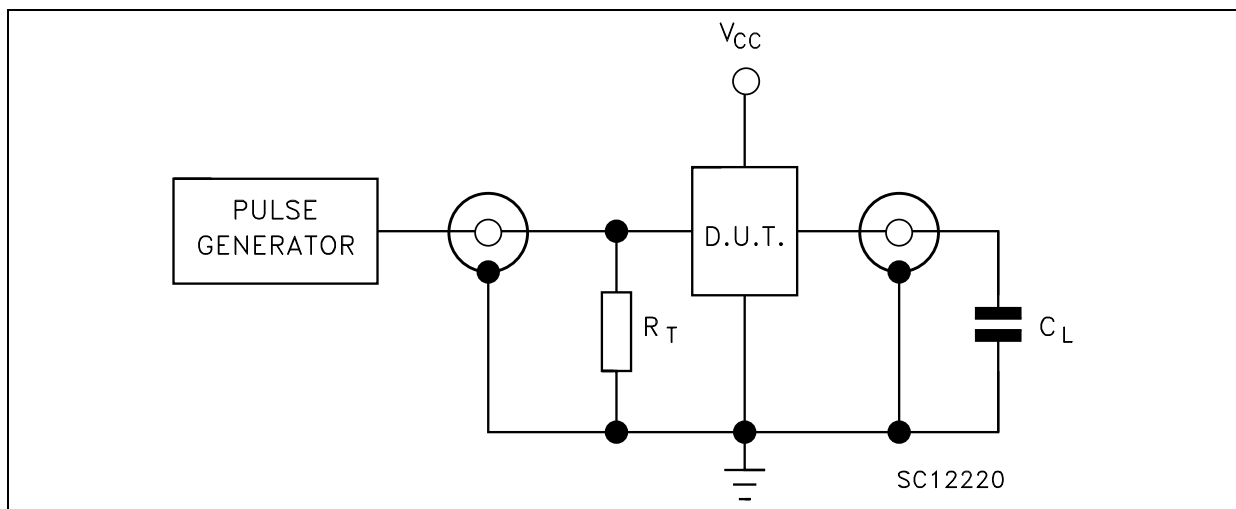

C_L = 50pF or equivalent (includes jig and probe capacitance)
 R_T = Z_{OUT} of pulse generator (typically 50Ω)

WAVEFORM : PROPAGATION DELAY TIMES (f=1MHz; 50% duty cycle)

