



PD85015-E

RF power transistor, LdmoST plastic family N-channel enhancement-mode lateral MOSFETs

Features

- Excellent thermal stability
- Common source configuration
- $P_{OUT} = 15\text{ W}$ with 16 dB gain @ 870 MHz / 13.6 V
- Plastic package
- ESD protection
- In compliance with the 2002/95/EC European directive

Description

The PD85015-E is a common source N-channel, enhancement-mode, lateral field-effect RF power transistor. It is designed for high gain, broadband, commercial and industrial applications. It operates at 13.6 V in common source mode at frequencies of up to 1 GHz. The PD85015-E boasts excellent gain, linearity and reliability thanks to ST's latest LDMOS technology mounted on the first true SMD plastic RF power package, the PowerSO-10RF. The superior linearity of the device makes it an ideal solution for car radios. The PowerSO-10 plastic package, designed for high reliability, is the first JEDEC approved, high power SMD package from ST. It is optimized for RF requirements, and offers excellent RF performance and ease of assembly.

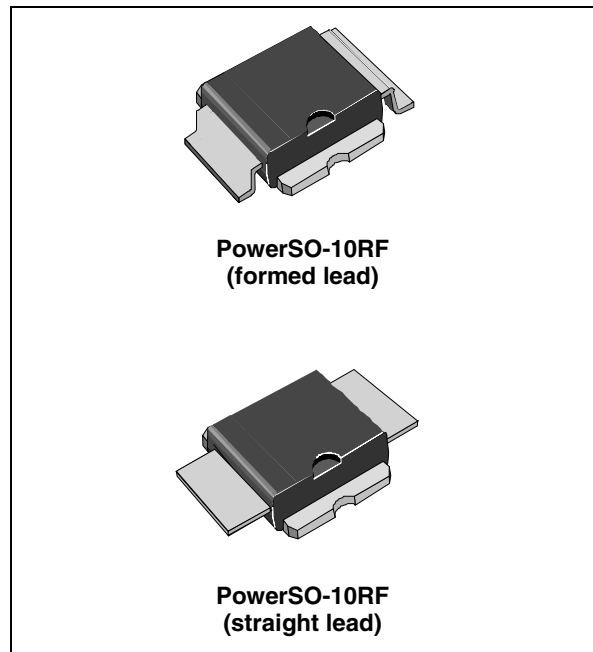

Figure 1. Pin connection

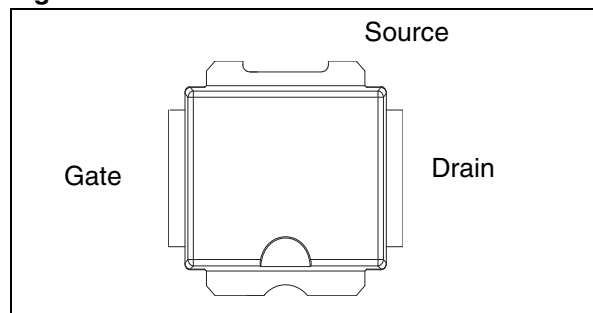

Table 1. Device summary

Order codes	Package	Packaging
PD85015-E	PowerSO-10RF (formed lead)	Tube
PD85015S-E	PowerSO-10RF (straight lead)	Tube
PD85015TR-E	PowerSO-10RF (formed lead)	Tape and reel
PD85015STR-E	PowerSO-10RF (straight lead)	Tape and reel

Contents

1	Electrical data	3
1.1	Maximum ratings	3
1.2	Thermal data	3
2	Electrical characteristics	4
2.1	Static	4
2.2	Dynamic	4
2.3	ESD protection characteristics	4
3	Impedance	5
4	Typical performances	6
5	Package mechanical data	7
6	Revision history	12

1 Electrical data

1.1 Maximum ratings

Table 2. Absolute maximum ratings ($T_{CASE} = 25\text{ °C}$)

Symbol	Parameter	Value	Unit
$V_{(BR)DSS}$	Drain-source voltage	40	V
V_{GS}	Gate-source voltage	-0.5 to +15	V
I_D	Drain current	5	A
P_{DISS}	Power dissipation (@ $T_C = 70\text{ °C}$)	59	W
T_J	Max. operating junction temperature	165	°C
T_{STG}	Storage temperature	-65 to +150	°C

1.2 Thermal data

Table 3. Thermal data

Symbol	Parameter	Value	Unit
R_{thJC}	Junction - case thermal resistance	1.6	°C/W

2 Electrical characteristics

$$T_{CASE} = +25\text{ }^{\circ}\text{C}$$

2.1 Static

Table 4. Static

Symbol	Test conditions		Min	Typ	Max	Unit
I_{DSS}	$V_{GS} = 0V$	$V_{DS} = 25 V$	-		1	μA
I_{GSS}	$V_{GS} = 5 V$	$V_{DS} = 0 V$			1	μA
$V_{GS(Q)}$	$V_{DS} = 10 V$	$I_D = 150\text{ mA}$			3.4	V
$V_{DS(ON)}$	$V_{GS} = 10 V$	$I_D = 1 A$			0.34	V
C_{ISS}	$V_{GS} = 0V$	$V_{DS} = 12.5 V$			45	pF
C_{OSS}	$V_{GS} = 0V$	$V_{DS} = 12.5 V$			36	pF
C_{RSS}	$V_{GS} = 0V$	$V_{DS} = 12.5 V$			1.2	pF

2.2 Dynamic

Table 5. Dynamic

Symbol	Test conditions		Min	Typ	Max	Unit
P3dB	$V_{DD} = 13.6 V, I_{DQ} = 150\text{ mA}$	$f = 870\text{ MHz}$	15	20	-	W
G_P	$V_{DD} = 13.6 V, I_{DQ} = 150\text{ mA}, P_{OUT} = 15\text{ W}, f = 870\text{ MHz}$		16			dB
h_D	$V_{DD} = 13.6 V, I_{DQ} = 150\text{ mA}, P_{OUT} = P_{3dB}, f = 870\text{ MHz}$		60	70		%
Load mismatch	$V_{DD} = 1.7 V, I_{DQ} = 300\text{ mA}, P_{OUT} = 25\text{ W}, f = 870\text{ MHz}$ All phase angles		20:1			VSWR

2.3 ESD protection characteristics

Table 6. ESD protection characteristics

Test conditions	Class
Human body model	2
Machine model	M3

3 Impedance

Figure 2. Current conventions

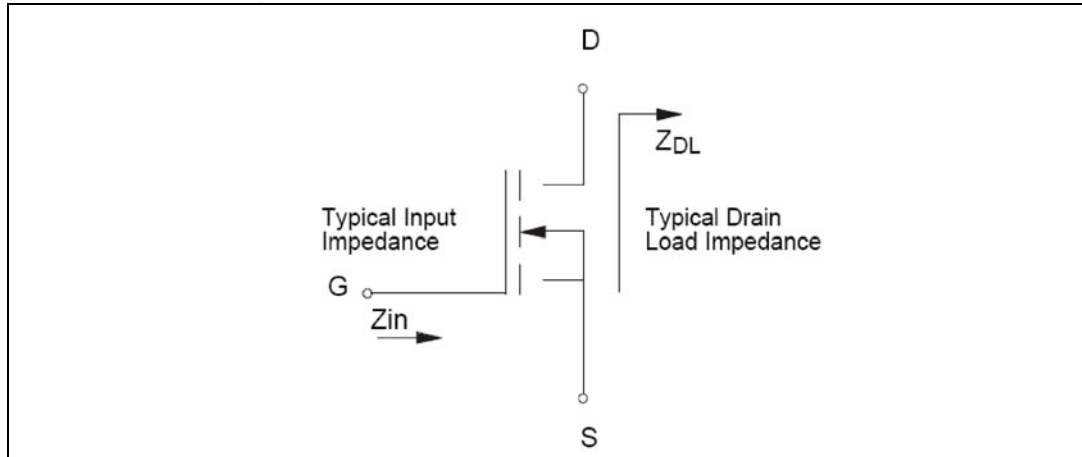

Table 7. Impedance data

Frequency	$Z_{IN} (\Omega)$	$Z_{DL} (\Omega)$
500 MHz	$0.536 - j 2.968$	$4.930 + j 1.083$
600 MHz	$0.557 - j 1.224$	$4.329 + j 0.811$
700 MHz	$0.595 + j 0.236$	$3.784 + j 0.429$
800 MHz	$0.651 + j 1.512$	$3.305 - j 0.031$
900 MHz	$0.708 + j 2.671$	$2.889 - j 0.542$
1000 MHz	$0.761 + j 3.759$	$2.534 - j 1.085$

4 Typical performances

Figure 3. Drain current vs gate voltage Figure 4. DC output characteristics

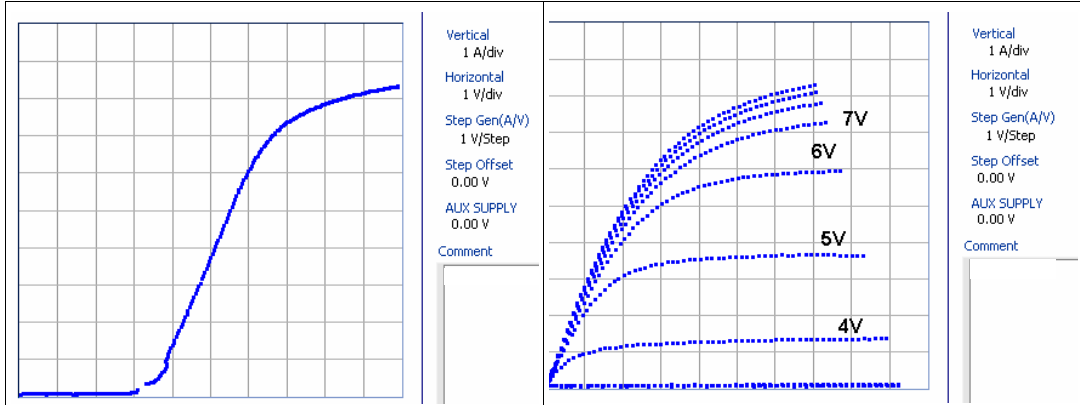
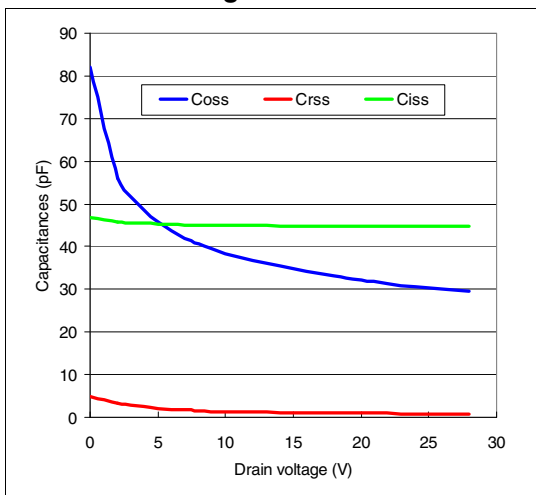

Figure 5. Capacitances vs drain voltage



5 Package mechanical data

In order to meet environmental requirements, ST offers these devices in different grades of ECOPACK[®] packages, depending on their level of environmental compliance. ECOPACK[®] specifications, grade definitions and product status are available at: www.st.com. ECOPACK[®] is an ST trademark.

Table 8. PowerSO-10RF formed lead (gull wing) mechanical data

Dim.	mm.			Inch		
	Min	Typ	Max	Min	Typ	Max
A1	0	0.05	0.1	0.	0.0019	0.0038
A2	3.4	3.5	3.6	0.134	0.137	0.142
A3	1.2	1.3	1.4	0.046	0.05	0.054
A4	0.15	0.2	0.25	0.005	0.007	0.009
a		0.2			0.007	
b	5.4	5.53	5.65	0.212	0.217	0.221
c	0.23	0.27	0.32	0.008	0.01	0.012
D	9.4	9.5	9.6	0.370	0.374	0.377
D1	7.4	7.5	7.6	0.290	0.295	0.298
E	13.85	14.1	14.35	0.544	0.555	0.565
E1	9.3	9.4	9.5	0.365	0.37	0.375
E2	7.3	7.4	7.5	0.286	0.292	0.294
E3	5.9	6.1	6.3	0.231	0.24	0.247
F		0.5			0.019	
G		1.2			0.047	
L	0.8	1	1.1	0.030	0.039	0.042
R1			0.25			0.01
R2		0.8			0.031	
T	2 deg	5 deg	8 deg	2 deg	5 deg	8 deg
T1		6 deg			6 deg	
T2		10 deg			10 deg	

Note: Resin protrusions not included (max value: 0.15 mm per side)

Figure 6. Package dimensions

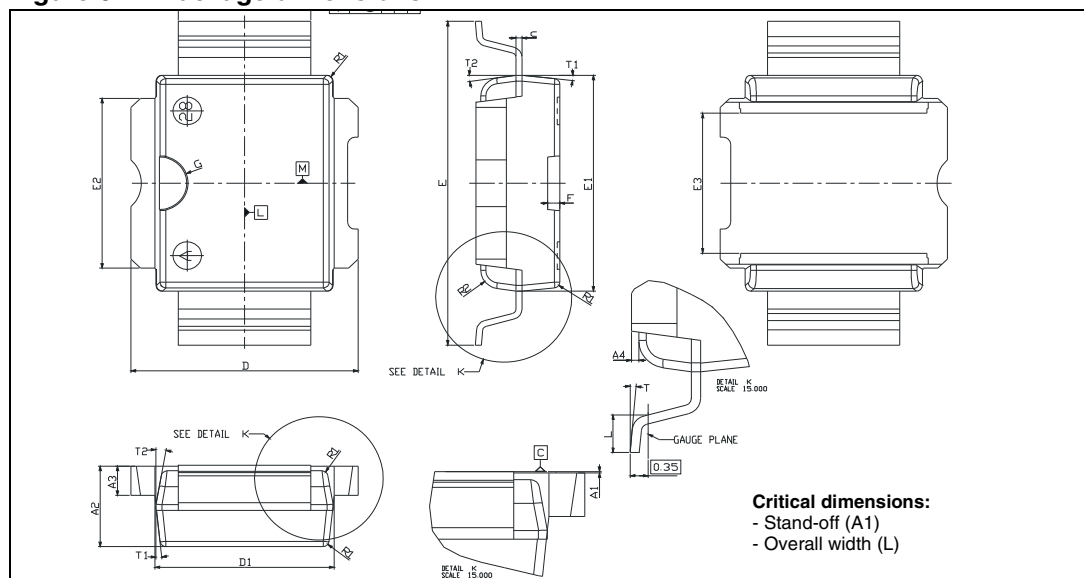

Table 9. PowerSO-10RF straight lead mechanical data

Dim.	mm.			Inch		
	Min	Typ	Max	Min	Typ	Max
A1	1.62	1.67	1.72	0.064	0.065	0.068
A2	3.4	3.5	3.6	0.134	0.137	0.142
A3	1.2	1.3	1.4	0.046	0.05	0.054
A4	0.15	0.2	0.25	0.005	0.007	0.009
a		0.2			0.007	
b	5.4	5.53	5.65	0.212	0.217	0.221
c	0.23	0.27	0.32	0.008	0.01	0.012
D	9.4	9.5	9.6	0.370	0.374	0.377
D1	7.4	7.5	7.6	0.290	0.295	0.298
E	15.15	15.4	15.65	0.595	0.606	0.615
E1	9.3	9.4	9.5	0.365	0.37	0.375
E2	7.3	7.4	7.5	0.286	0.292	0.294
E3	5.9	6.1	6.3	0.231	0.24	0.247
F		0.5			0.019	
G		1.2			0.047	
R1			0.25			0.01
R2		0.8			0.031	
T1		6 deg			6 deg	
T2		10 deg			10 deg	

Note: Resin protrusions not included (max value: 0.15 mm per side)

Figure 7. Package dimensions

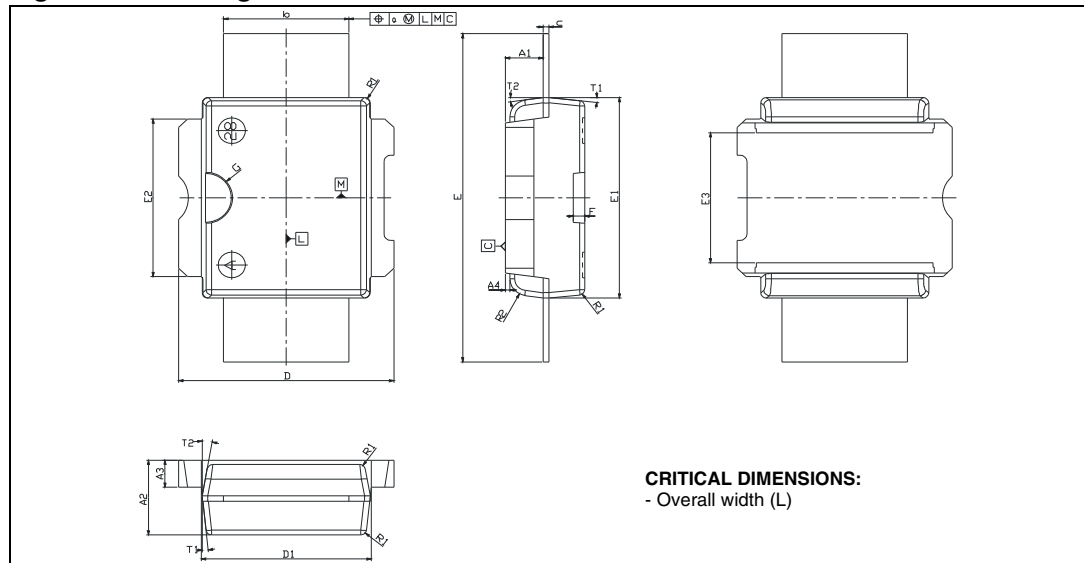

Figure 8. Tube information

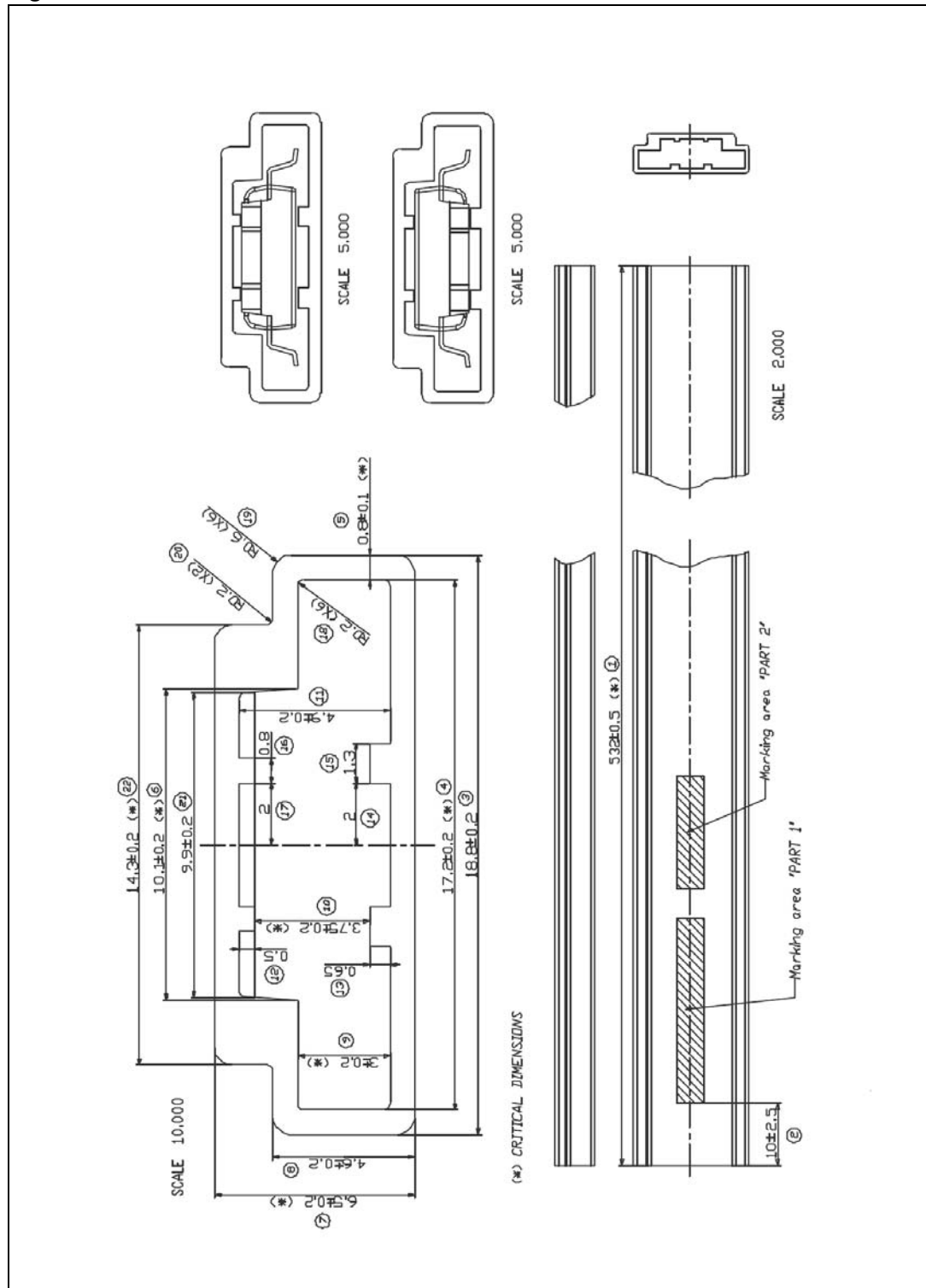
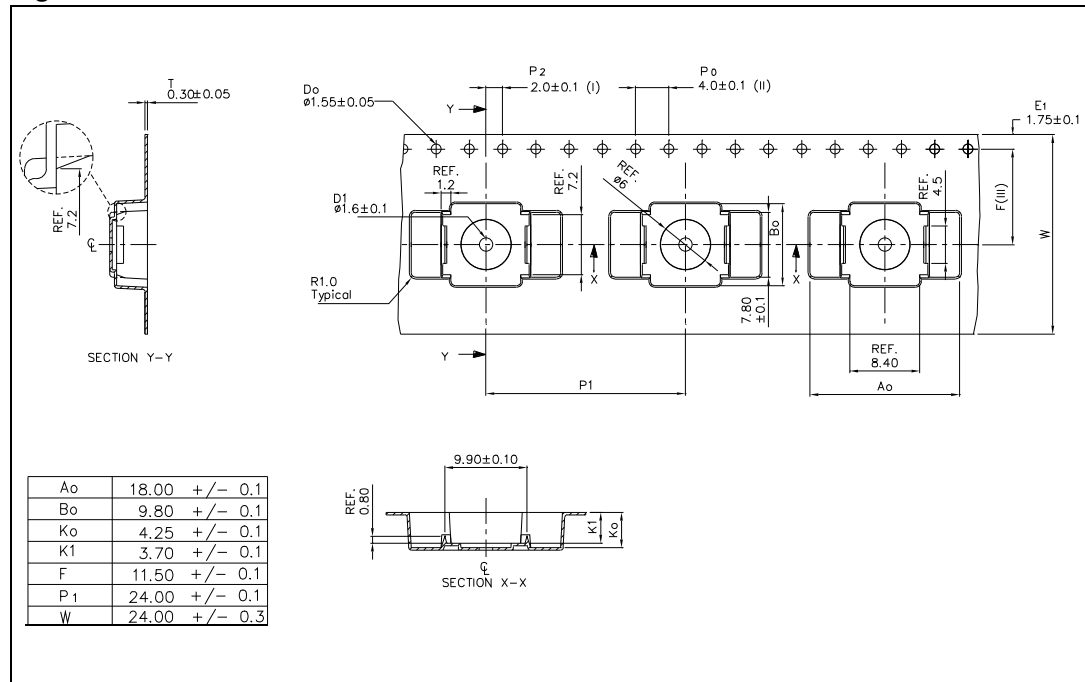

Figure 9. Reel information



6 Revision history

Table 10. Document revision history

Date	Revision	Changes
10-Mar-2008	1	Initial release
06-Jul-2009	2	Document status promoted from preliminary data to datasheet.
13-Dec-2011	3	Updated values in Table 7: Impedance data .

Please Read Carefully:

Information in this document is provided solely in connection with ST products. STMicroelectronics NV and its subsidiaries ("ST") reserve the right to make changes, corrections, modifications or improvements, to this document, and the products and services described herein at any time, without notice.

All ST products are sold pursuant to ST's terms and conditions of sale.

Purchasers are solely responsible for the choice, selection and use of the ST products and services described herein, and ST assumes no liability whatsoever relating to the choice, selection or use of the ST products and services described herein.

No license, express or implied, by estoppel or otherwise, to any intellectual property rights is granted under this document. If any part of this document refers to any third party products or services it shall not be deemed a license grant by ST for the use of such third party products or services, or any intellectual property contained therein or considered as a warranty covering the use in any manner whatsoever of such third party products or services or any intellectual property contained therein.

UNLESS OTHERWISE SET FORTH IN ST'S TERMS AND CONDITIONS OF SALE ST DISCLAIMS ANY EXPRESS OR IMPLIED WARRANTY WITH RESPECT TO THE USE AND/OR SALE OF ST PRODUCTS INCLUDING WITHOUT LIMITATION IMPLIED WARRANTIES OF MERCHANTABILITY, FITNESS FOR A PARTICULAR PURPOSE (AND THEIR EQUIVALENTS UNDER THE LAWS OF ANY JURISDICTION), OR INFRINGEMENT OF ANY PATENT, COPYRIGHT OR OTHER INTELLECTUAL PROPERTY RIGHT.

UNLESS EXPRESSLY APPROVED IN WRITING BY TWO AUTHORIZED ST REPRESENTATIVES, ST PRODUCTS ARE NOT RECOMMENDED, AUTHORIZED OR WARRANTED FOR USE IN MILITARY, AIR CRAFT, SPACE, LIFE SAVING, OR LIFE SUSTAINING APPLICATIONS, NOR IN PRODUCTS OR SYSTEMS WHERE FAILURE OR MALFUNCTION MAY RESULT IN PERSONAL INJURY, DEATH, OR SEVERE PROPERTY OR ENVIRONMENTAL DAMAGE. ST PRODUCTS WHICH ARE NOT SPECIFIED AS "AUTOMOTIVE GRADE" MAY ONLY BE USED IN AUTOMOTIVE APPLICATIONS AT USER'S OWN RISK.

Resale of ST products with provisions different from the statements and/or technical features set forth in this document shall immediately void any warranty granted by ST for the ST product or service described herein and shall not create or extend in any manner whatsoever, any liability of ST.

ST and the ST logo are trademarks or registered trademarks of ST in various countries.

Information in this document supersedes and replaces all information previously supplied.

The ST logo is a registered trademark of STMicroelectronics. All other names are the property of their respective owners.

© 2011 STMicroelectronics - All rights reserved

STMicroelectronics group of companies

Australia - Belgium - Brazil - Canada - China - Czech Republic - Finland - France - Germany - Hong Kong - India - Israel - Italy - Japan - Malaysia - Malta - Morocco - Philippines - Singapore - Spain - Sweden - Switzerland - United Kingdom - United States of America

www.st.com

