

## Rad-hard adjustable positive voltage regulator

### Features

- 3 A low dropout voltage
- Embedded overtemperature and overcurrent protection
- Adjustable overcurrent limitation
- Output overload monitoring/signalling
- Adjustable output voltage
- Inhibit (ON/OFF) TTL-compatible control
- Programmable output short-circuit current
- Remote sensing operation
- Rad-hard: guaranteed up to 300 krad Mil Std 883E Method 1019.6 high dose rate and 0.01 rad/s in ELDRS conditions
- Heavy ion, SEL immune

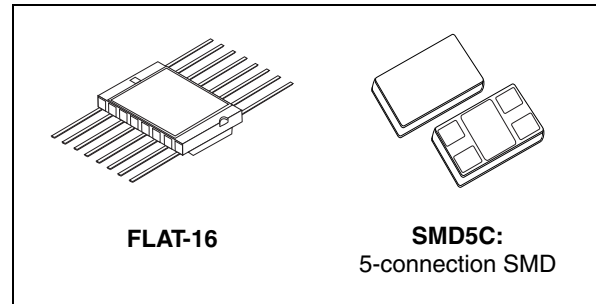

### Description

The RHFL4913 high-performance adjustable positive voltage regulator provides exceptional radiation performance. It is tested in accordance with Mil Std 883E Method 1019.6, in ELDRS conditions.

The device is available in the FLAT-16 and the new SMD5C hermetic ceramic package, and the QML-V die is specifically designed for space and harsh radiation environments. It operates with an input supply of up to 12 volts.

The RHFL4913 is QML-V qualified, DSCC SMD #5962F02524.

# Contents

<b>1</b>	<b>Diagram</b> .....	<b>3</b>
<b>2</b>	<b>Pin configuration</b> .....	<b>4</b>
<b>3</b>	<b>Maximum ratings</b> .....	<b>5</b>
<b>4</b>	<b>Electrical characteristics</b> .....	<b>6</b>
<b>5</b>	<b>Device description</b> .....	<b>8</b>
5.1	ADJ pin .....	8
5.2	Inhibit ON-OFF control .....	8
5.3	Overtemperature protection .....	8
5.4	Overcurrent protection .....	8
5.5	OCM pin .....	8
5.6	Alternatives to the RHFL4913 .....	9
<b>6</b>	<b>Application information</b> .....	<b>10</b>
6.1	Notes on the 16-pin hermetic package .....	10
6.2	Remote sensing operation .....	10
6.3	FPGA power supply lines .....	11
<b>7</b>	<b>Die information</b> .....	<b>12</b>
7.1	Die bonding pad locations and electrical functions .....	13
<b>8</b>	<b>Package mechanical data</b> .....	<b>14</b>
<b>9</b>	<b>Packaging</b> .....	<b>17</b>
<b>10</b>	<b>Ordering information</b> .....	<b>18</b>
<b>11</b>	<b>Revision history</b> .....	<b>19</b>

# 1 Diagram

Figure 1. Block diagram

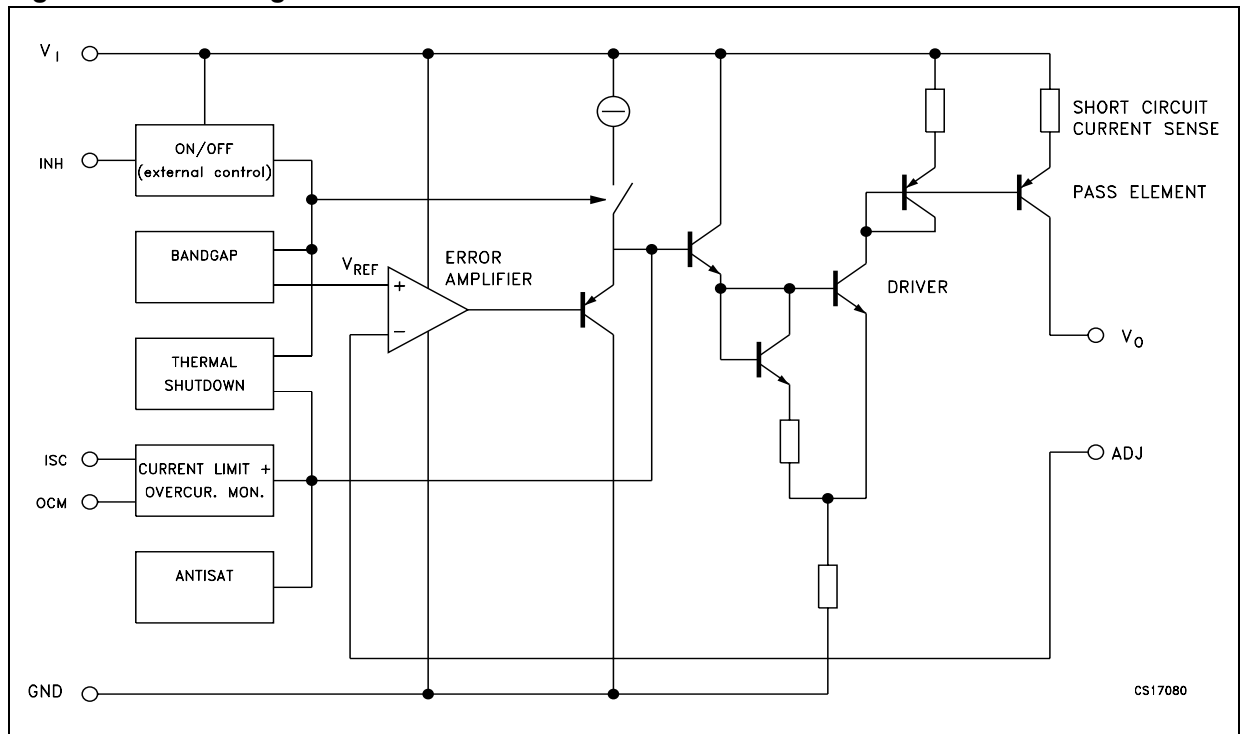

## 2 Pin configuration

Figure 2. Pin configuration (top view for FLAT-16, bottom view for SMD5C)

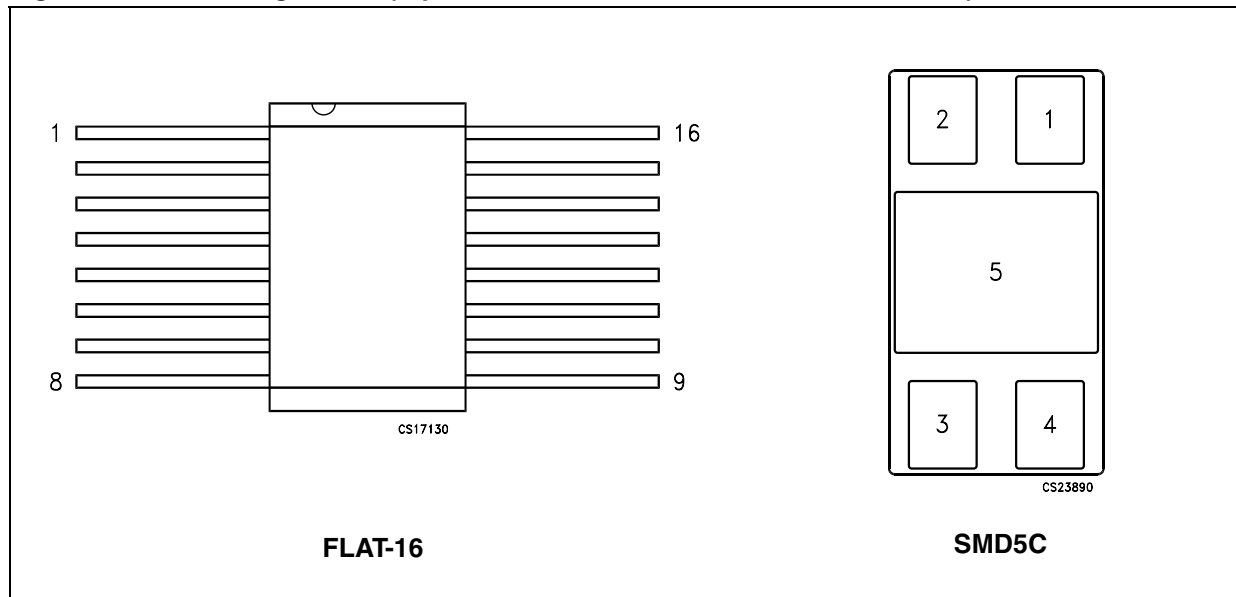

Table 1. Pin description

Pin name	FLAT-16	SMD5C
$V_O$	1, 2, 6, 7	1
$V_I$	3, 4, 5	4
GND	13	5
$I_{sc}$	8	
OCM	10	
INHIBIT	14	3
ADJ	15	2
NC	9, 11, 12, 16	

### 3 Maximum ratings

**Table 2. Recommended maximum operating ratings <sup>(1)</sup>**

Symbol	Parameter	Value	Unit
$V_I$	DC input voltage, $V_I - V_{\text{GROUND}}$	12	V
$V_O$	DC output voltage range	1.23 to 9	V
$I_O$	Output current, RHFL4913KPA	2	A
$I_O$	Output current, RHFL4913SCA	3	
$P_D$	$T_C = 25\text{ °C}$ power dissipation	15	W
$T_{\text{stg}}$	Storage temperature range	-65 to +150	°C
$T_{\text{op}}$	Operating junction temperature range	-55 to +150	°C
ESD	Electrostatic discharge capability	Class 3	

1. Exceeding maximum ratings may damage the device.

**Table 3. Thermal data**

Symbol	Parameter	Value	Unit
$R_{\text{thJC}}$	Thermal resistance junction-case, FLAT-16 and SMD5C	8.3	°C/W
$T_{\text{SOLD}}$	Maximum soldering temperature, 10 sec.	300	°C

## 4 Electrical characteristics

**Table 4. Electrical characteristics**  
( $T_J = 25\text{ °C}$ ,  $V_I = V_O + 2.5\text{ V}$ ,  $C_I = C_O = 1\text{ }\mu\text{F}$ , unless otherwise specified)

Symbol	Parameter	Test conditions	Min.	Typ.	Max.	Unit
$V_I$	Operating input voltage	$I_O = 1\text{ A}$ , $T_J = -55\text{ to }125\text{ °C}$	3		12	V
$V_O$	Operating output voltage	$I_O = 1\text{ A}$ and or 2, $V_O = 1.23\text{ V}$	1.19		1.27	V
		$I_O = 1\text{ A}$ and or 2, $V_O = 9\text{ V}$	8.7		9.3	V
$I_{\text{SHORT}}$	Output current limit <sup>(1)</sup>	Adjustable by mask/external resistor	1	4.5		A
$\Delta V_O / \Delta V_I$	Line regulation	$V_I = V_O + 2.5\text{ V}$ to $12\text{ V}$ , $I_O = 5\text{ mA}$ , $T_J = +25\text{ °C}$			0.35	%
		$V_I = V_O + 2.5\text{ V}$ to $12\text{ V}$ , $I_O = 5\text{ mA}$ , $T_J = -55\text{ °C}$			0.4	
		$V_I = V_O + 2.5\text{ V}$ to $12\text{ V}$ , $I_O = 5\text{ mA}$ , $T_J = +125\text{ °C}$			0.4	
$\Delta V_O / \Delta V_O$	Load regulation	$V_I = V_O + 2.5\text{ V}$ , $I_O = 5\text{ to }400\text{ mA}$ , $T_J = +25\text{ °C}$			0.3	%
		$V_I = V_O + 2.5\text{ V}$ , $I_O = 5\text{ to }400\text{ mA}$ , $T_J = -55\text{ °C}$			0.5	
		$V_I = V_O + 2.5\text{ V}$ , $I_O = 5\text{ to }400\text{ mA}$ , $T_J = +125\text{ °C}$			0.5	
		$V_I = V_O + 2.5\text{ V}$ , $I_O = 5\text{ mA to }1\text{ A}$ , $T_J = +25\text{ °C}$			0.5	
		$V_I = V_O + 2.5\text{ V}$ , $I_O = 5\text{ mA to }1\text{ A}$ , $T_J = -55\text{ °C}$			0.6	
		$V_I = V_O + 2.5\text{ V}$ , $I_O = 5\text{ mA to }1\text{ A}$ , $T_J = +125\text{ °C}$			0.6	
$Z_{\text{OUT}}$	Output impedance	$I_O = 100\text{ mA DC}$ and $20\text{ mA rms}$		100		m $\Omega$
$I_q$	Quiescent current	$V_I = V_O + 2.5\text{ V}$ , $I_O = 5\text{ mA}$ , ON mode (+25 $^{\circ}\text{C}$ )			6	mA
		$V_I = V_O + 2.5\text{ V}$ , $I_O = 30\text{ mA}$ , ON mode (+25 $^{\circ}\text{C}$ )			8	
		$V_I = V_O + 2.5\text{ V}$ , $I_O = 300\text{ mA}$ , ON mode (+25 $^{\circ}\text{C}$ )			25	
		$V_I = V_O + 2.5\text{ V}$ , $I_O = 1\text{ A}$ , ON mode (+25 $^{\circ}\text{C}$ )			60	
		$V_I = V_O + 2\text{ V}$ , $V_{\text{INH}} = 2.4\text{ V}$ , OFF mode			1	
$I_q$	Quiescent current ON mode	$V_I = V_O + 2.5\text{ V}$ , $I_O = 30\text{ mA}$ , (-55 $^{\circ}\text{C}$ )			14	mA
		$V_I = V_O + 2.5\text{ V}$ , $I_O = 300\text{ mA}$ , (-55 $^{\circ}\text{C}$ )			40	
		$V_I = V_O + 2.5\text{ V}$ , $I_O = 1\text{ A}$ , (-55 $^{\circ}\text{C}$ )			100	
		$V_I = V_O + 2.5\text{ V}$ , $I_O = 30\text{ mA}$ , (+125 $^{\circ}\text{C}$ )			8	
		$V_I = V_O + 2.5\text{ V}$ , $I_O = 300\text{ mA}$ , (+125 $^{\circ}\text{C}$ )			20	
		$V_I = V_O + 2.5\text{ V}$ , $I_O = 1\text{ A}$ , (+125 $^{\circ}\text{C}$ )			40	

**Table 4. Electrical characteristics (continued)** $(T_J = 25\text{ }^\circ\text{C}, V_I = V_O + 2.5\text{ V}, C_I = C_O = 1\text{ }\mu\text{F}, \text{ unless otherwise specified})$ 

Symbol	Parameter	Test conditions	Min.	Typ.	Max.	Unit
$V_d$	Dropout voltage	$I_O = 400\text{ mA}, V_O = 2.5\text{ to }9\text{ V}, (+25^\circ\text{C})$		350	450	mV
		$I_O = 400\text{ mA}, V_O = 2.5\text{ to }9\text{ V}, (-55^\circ\text{C})$		300	400	
		$I_O = 400\text{ mA}, V_O = 2.5\text{ to }9\text{ V}, (+125^\circ\text{C})$		450	550	
		$I_O = 1\text{ A}, V_O = 2.5\text{ to }9\text{ V}, (+25^\circ\text{C})$			650	
		$I_O = 1\text{ A}, V_O = 2.5\text{ to }9\text{ V}, (-55^\circ\text{C})$			550	
		$I_O = 1\text{ A}, V_O = 2.5\text{ to }9\text{ V}, (+125^\circ\text{C})$			800	
		$I_O = 2\text{ A}, V_O = 2.5\text{ to }9\text{ V}, (+25^\circ\text{C})$		900		
		$I_O = 2\text{ A}, V_O = 2.5\text{ to }9\text{ V}, (+125^\circ\text{C})$		950		
$V_{INH(ON)}$	Inhibit voltage	$I_O = 5\text{ mA}, T_J = -55\text{ to }+125^\circ\text{C}$			0.8	V
$V_{INH(OFF)}$	Inhibit voltage	$I_O = 5\text{ mA}, T_J = -55\text{ to }+125^\circ\text{C}$	2.4			
SVR	Supply voltage rejection <sup>(1)</sup>	$V_I = V_O + 2.5\text{ V} \pm 0.5\text{ V},$ $V_O = 3\text{ V}, I_O = 5\text{ mA}$	$f = 120\text{ Hz}$	60	70	dB
			$f = 33\text{ kHz}$	30	40	
$I_{SH}$	Shutdown input current	$V_{INH} = 5\text{ V}$		15		$\mu\text{A}$
$V_{OCM}$	OCM pin voltage	Sinked $I_{OCM} = 24\text{ mA}$ active low		0.38		V
$t_{PLH}$ $t_{PHL}$	Inhibit propagation delay <sup>(1)</sup>	$V_I = V_O + 2.5\text{ V}, V_{INH} = 2.4\text{ V}, I_O = 400\text{ mA}$ $V_O = 3\text{ V}$	ON-OFF		20	$\mu\text{s}$
			OFF-ON		100	$\mu\text{s}$
eN	Output noise voltage <sup>(1)</sup>	$B = 10\text{ Hz to }100\text{ kHz}, I_O = 5\text{ mA to }2\text{ A}$		40		$\mu\text{Vrms}$

1. These values are guaranteed by design. For each application it is strongly recommended to comply with the maximum current limit of the package used.

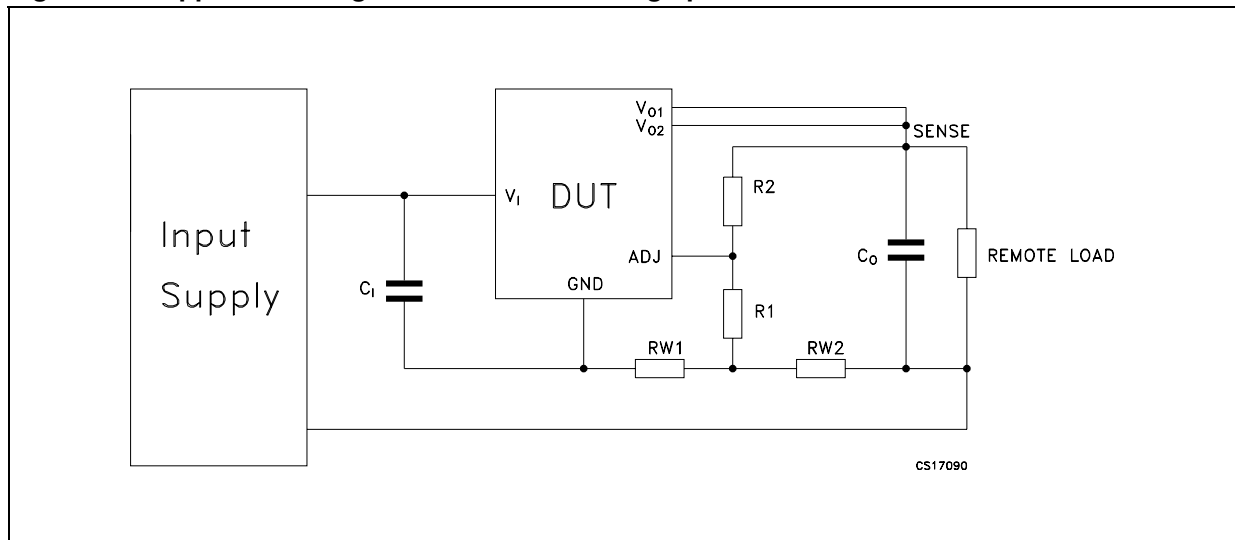
**Figure 3. Application diagram for remote sensing operation**

## 5 Device description

The RHFL4913 adjustable voltage regulator contains a PNP type power element controlled by a signal resulting from an amplified comparison between the internal temperature-compensated band-gap and the fraction of the desired output voltage value obtained from an external resistor divider bridge. The device is protected by several functional blocks.

### 5.1 ADJ pin

The load output voltage feedback comes from an external resistor divider bridge mid-point connected to the ADJ pin (allowing all possible output voltage settings as per user requirements) established between load terminals.

### 5.2 Inhibit ON-OFF control

By setting the INHIBIT pin TTL high, the device switches off the output current and voltage. The device is ON when the INHIBIT pin is set low. Since the INHIBIT pin is pulled down internally, it can be left floating in cases where the inhibit function is not used.

### 5.3 Overtemperature protection

A temperature detector internally monitors the power element junction temperature. The device turns off when a temperature of approximately 175 °C is reached, returning to ON mode when back to approximately 135 °C. Combined with the other protection blocks, the device is protected from destructive junction temperature excursions in all load conditions. It should be noted that when the internal temperature detector reaches 175 °C, the active power element can be as high as 225 °C. Prolonged operation under these conditions far exceeds the maximum operating ratings and device reliability cannot be guaranteed.

### 5.4 Overcurrent protection

An internal non fold-back short circuit limitation is set with  $I_{\text{SHORT}} > 3.8 \text{ A}$  ( $V_{\text{O}}$  is 0 V). This value can be decreased via an external resistor connected between the  $I_{\text{SC}}$  and  $V_{\text{I}}$  pins, with a typical value range of 10 k $\Omega$  to 200 k $\Omega$ . To maintain optimal  $V_{\text{O}}$  regulation, it is necessary to set  $I_{\text{SHORT}}$  1.6 times greater than the maximum desired application  $I_{\text{O}}$ . When  $I_{\text{O}}$  reaches  $I_{\text{SHORT}} - 300 \text{ mA}$ , the current limiter overrules the regulation,  $V_{\text{O}}$  starts to drop and the OCM flag is raised. When no current limitation adjustment is required, the  $I_{\text{SC}}$  pin must be left unbiased (as it is in 3 pin packages).

### 5.5 OCM pin

The OCM pin goes low when the current limit becomes active, otherwise  $V_{\text{OCM}} = V_{\text{I}}$ . It is buffered and can sink 10 mA. The OCM pin is internally pulled up by a 5 k $\Omega$  resistor.

## 5.6 Alternatives to the RHFL4913

The adjustable RHFL4913 is recommended to replace all industry positive voltage regulators due to its exceptional radiation performance. To replace 3-terminal industry devices, the fixed voltage versions of the RHFL4913 should be used.

## 6 Application information

To adjust the output voltage, the R2 resistor must be connected between the  $V_O$  and ADJ pins. The R1 resistor must be connected between ADJ and ground. Resistor values can be derived from the following formula:

$$V_O = V_{ADJ} (R1 + R2) / R1$$

The  $V_{ADJ}$  is 1.23 V, controlled by the internal temperature-compensated band gap block.

The minimum output voltage is therefore 1.22 V and minimum input voltage is 3 V.

The RHFL4913 adjustable is functional as soon as the  $V_I - V_O$  voltage difference is slightly above the power element saturation voltage. The adjust pin to ground resistor value must not be greater than 10 k $\Omega$ , in order to keep the output feedback error below 0.2%. A minimum of 0.5 mA  $I_O$  must be set to ensure perfect no-load regulation. It is advisable to dissipate this current into the divider bridge resistor. All available  $V_I$  pins, as well as all available  $V_O$  pins, should always be externally interconnected, otherwise the stability and reliability of the device cannot be guaranteed. The inhibit function switches off the output current electronically, and therefore very quickly. According to Lenz's Law, external circuitry reacts with  $Ldi/dt$  terms which can be of high amplitude in case somewhere a serial coil inductance exists. Large transient voltage would develop on both device terminals. It is advisable to protect the device with Schottky diodes to prevent negative voltage excursions. In the worst case, a 14 V Zener diode could protect the device input. The device has been designed for high stability and low dropout operation. Therefore, tantalum input and output capacitors with a minimum 1  $\mu$ F are mandatory. Capacitor ESR range is from 0.01  $\Omega$  to over 20  $\Omega$ . This range is useful when ESR increases at low temperature. When large transient currents are expected, larger value capacitors are necessary.

In the case of high current operation with short circuit events expected, caution must be exercised with regard to capacitors. They must be connected as close as possible to the device terminals. As some tantalum capacitors may permanently fail when subjected to high charge-up surge currents, it is recommended to decouple them with 470 nF polyester capacitors.

Since the RHFL4913 adjustable voltage regulator is manufactured with very high speed bipolar technology (6 GHz  $f_T$  transistors), the PCB layout must be designed with exceptional care, with very low inductance and low mutually coupling lines. Otherwise, high frequency parasitic signals may be picked up by the device resulting in system self-oscillation. The benefit is an SVR performance extended to far higher frequencies.

### 6.1 Notes on the 16-pin hermetic package

The bottom section of the 16-pin package is metallized in order to allow the user to directly solder the RHFL4913 onto the equipment heat sink for enhanced heat removal.

### 6.2 Remote sensing operation

A separate kelvin voltage sensing line provides the ADJ pin with exact load "high potential" information (see [Figure 3](#)). But variable remote load current consumption induces variable  $I_q$  current ( $I_q$  is roughly the  $I_O$  current divided by the  $h_{FE}$  of the internal PNP series power element) routed through the parasitic series line resistor RW2. To compensate for this

parasitic voltage, resistor RW1 can be introduced to provide the necessary compensating voltage signal to the ADJUST pin.

### 6.3 FPGA power supply lines

Because these devices are very sensitive to  $V_{DD}$  transients beyond a few % of their nominal supply voltage (usually 1.5 V), special attention must be given by supply lines designers to mitigate possible heavy ion L4913 disturbances. The worst case heavy ion effect can be summarized as: the L4913 internal control loop being cut (made open) or short-circuited for a sub-microsecond duration. During such an event, the L4913 die power element can either provide excessive current or current supply stoppage to the output ( $V_{OUT}$ ) for a duration of about one microsecond, after which time the L4913 smoothly recovers to nominal operation. To mitigate these "transients", it is recommended to implement the L4913 PCB layout as follows:

- Minimizing series/parallel parasitic inductances of the PC path
- Using a low ESR 47  $\mu$ F Tantalum  $V_{OUT}$  filtering capacitor with a 470 nF ceramic capacitor in parallel with the former (to reduce dynamic ESR)
- Inserting a 100-200 nH ferrite core on the  $V_{OUT}$ -to-tantalum capacitor wire

With this implementation, the ELDO simulated worst transient case shows no more than 90 mV deviation from the nominal line voltage value.

# 7 Die information

Figure 4. Die map

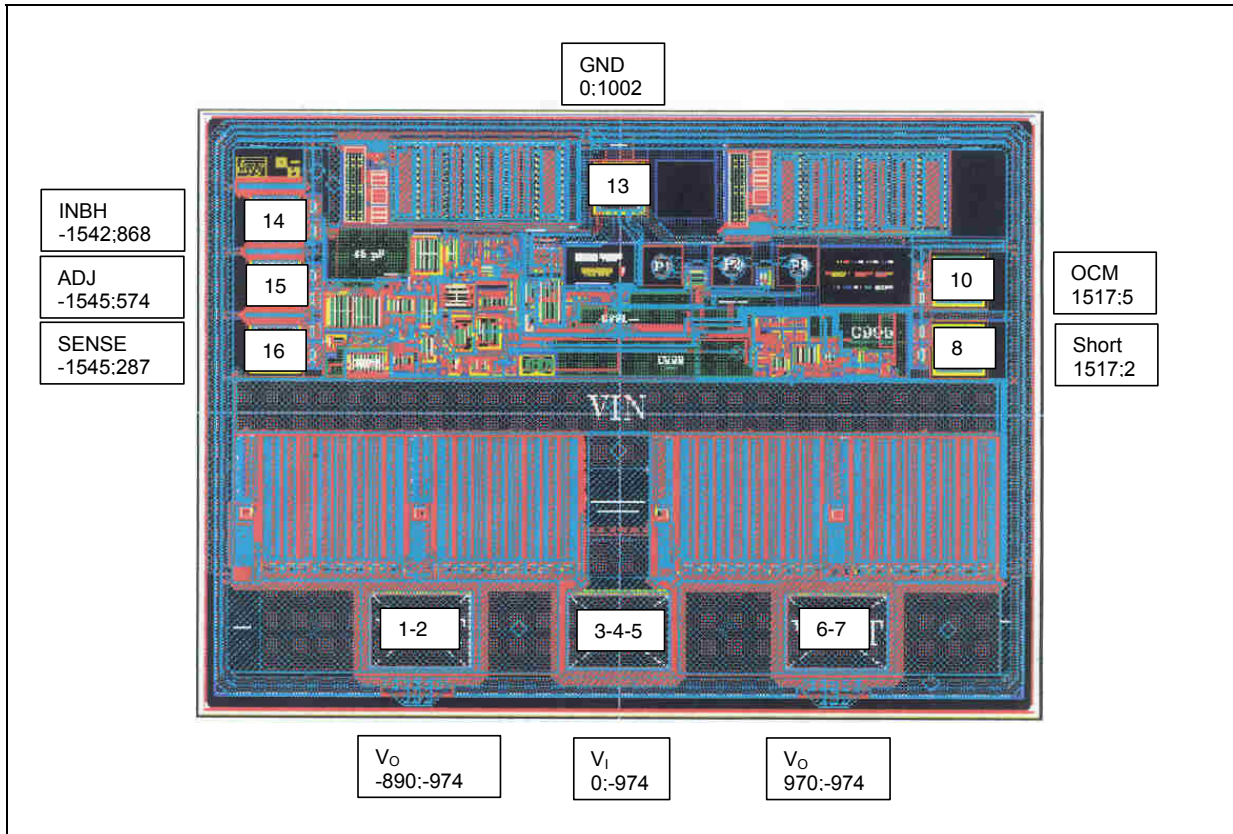

Note: Pad numbers reflect terminal numbers when placed in case FLAT-16.

## 7.1 Die bonding pad locations and electrical functions

Die physical dimensions:

Die size: 150 mils x 110 mils (3.81 mm by 2.79 mm)

Die thickness:  $375 \mu\text{m} \pm 25 \mu\text{m}$  (14.8 mils  $\pm$  1 mil)

Pad size:  $V_{IN}$ ,  $V_{OUT}$  pads:  $450 \mu\text{m} \times 330 \mu\text{m}$  (17.7 mils by 13 mils)

Control pads:  $184 \mu\text{m} \times 184 \mu\text{m}$  (7.25 mils square)

Interface materials:

Top metallization: Al/Si/Cu,  $1.05 \mu\text{m} \pm 0.15 \mu\text{m}$

Backside metallization: none

Glassivation:

Type: p. vapox + nitride

Thickness:  $0.6 \mu\text{m} \pm 0.1 \mu\text{m} + 0.6 \mu\text{m} \pm 0.08 \mu\text{m}$

Substrate: bare silicon

Assembly related information:

Substrate potential: floating recommended to be tied to ground

Special assembly instructions: "Sense" pad not used; not internally connected to any part of the IC. Can be connected to ground when space anti-static electricity rules apply.

## 8 Package mechanical data

In order to meet environmental requirements, ST offers these devices in ECOPACK® packages. These packages have a lead-free second level interconnect. The category of second Level Interconnect is marked on the package and on the inner box label, in compliance with JEDEC Standard JESD97. The maximum ratings related to soldering conditions are also marked on the inner box label. ECOPACK is an ST trademark. ECOPACK specifications are available at: [www.st.com](http://www.st.com).

### FLAT-16 (MIL-STD-1835) mechanical data

Dim.	mm.			inch.		
	Min.	Typ.	Max.	Min.	Typ.	Max.
A	2.16		2.72	0.085		0.107
b		0.43			0.017	
c		0.13			0.005	
D		9.91			0.390	
E		6.91			0.272	
E2		4.32			0.170	
E3	0.76			0.030		
e		1.27			0.050	
L		6.72			0.265	
Q	0.66		1.14	0.026		0.045
S1	0.13			0.005		

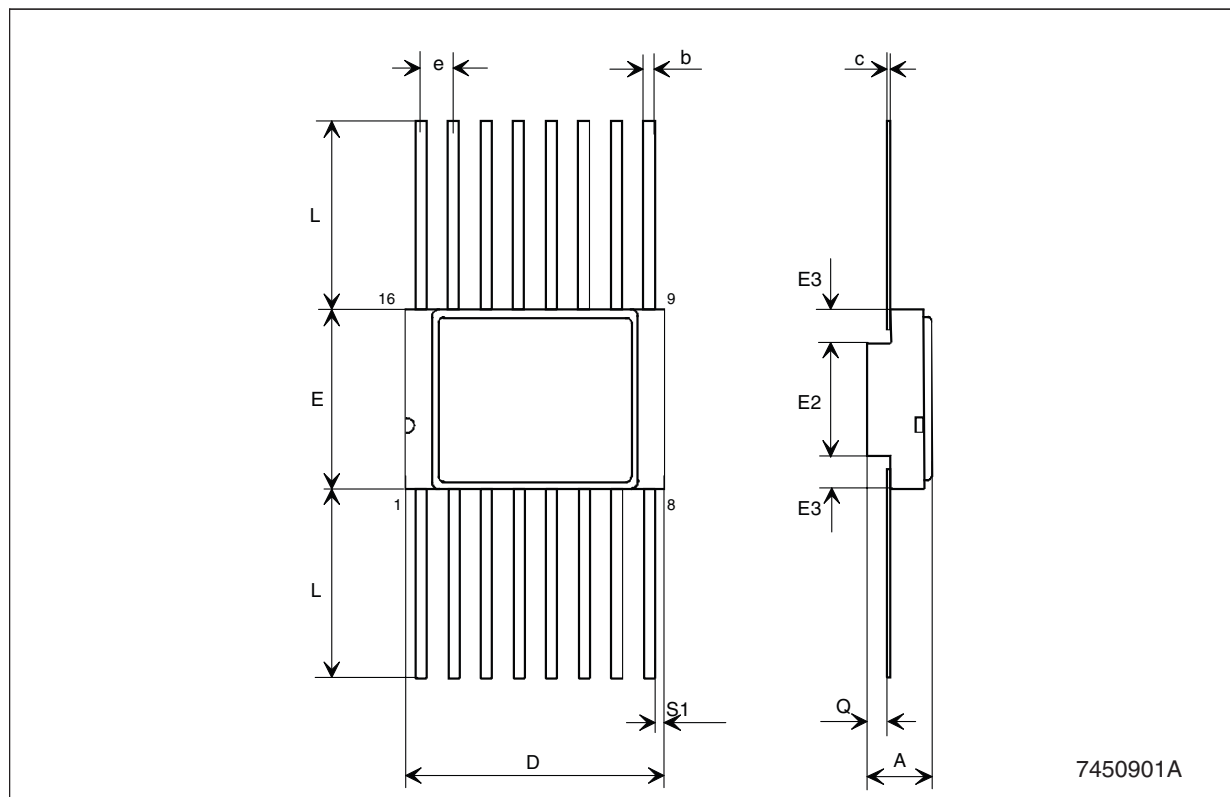

**SMD5C mechanical data**

Dim.	mm.			inch.		
	Min.	Typ.	Max.	Min.	Typ.	Max.
A	2.84	3.00	3.15	0.112	0.118	0.124
A1	0.25	0.38	0.51	0.010	0.015	0.020
b	7.13	7.26	7.39	0.281	0.286	0.291
b1	4.95	5.08	5.21	0.195	0.200	0.205
b2	2.28	2.41	2.54	0.090	0.095	0.100
b3	2.92	3.05	3.18	0.115	0.120	0.125
D	13.71	13.84	13.97	0.540	0.545	0.550
D1	0.76			0.030		
E	7.39	7.52	7.65	0.291	0.296	0.301
e		1.91			0.075	

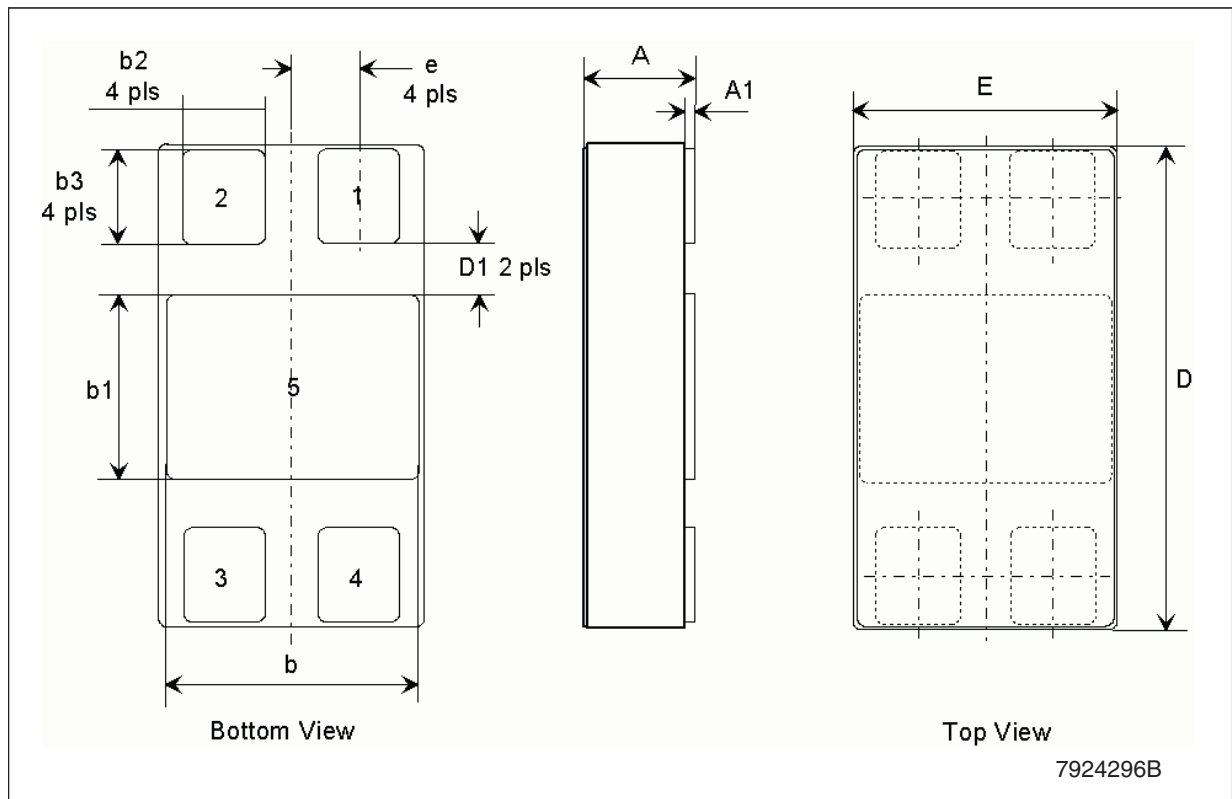

## 9 Packaging

The RHFL4913 adjustable voltage regulator is available in a high thermal dissipation 16-pin hermetic Flat package, the bottom flange of which is metallized to allow direct soldering to a heat sink (efficient thermal conductivity). The device is also available in the SMD5C hermetic ceramic package.

## 10 Ordering information

**Table 5. Order code**

Die	FLAT-16	SMD5C	Terminal finish	Output voltage	Quality level
	RHFL4913KPA-01V	RHFL49143SCA-07V	Gold	Adj	QML-V
	RHFL4913KPA-02V		Solder	Adj	QML-V
	RHFL4913KPA1	RHFL4913SCA1	Gold	Adj	EM1
	RHFL4913KPA2	RHFL4913SCA2	Gold	Adj	EM2=EM1+48hours B.I.
L4913ADIE2V				Adj	QML-V die
L4913ADIES				Adj	EM1 die

**Table 6. Part number - SMD equivalent**

ST part number	SMD part number
RHFL4913KPA-01V	5962F0252401VXC
RHFL4913KPA-02V	5962F0252401VXA
RHFL4913SCA-07V	5962F0252403VUC
L4913ADIE2V	5962F0252401V9A

**Table 7. Environmental characteristics**

Parameter	Conditions	Value	Unit
Output voltage thermal drift	-55°C to +125°C	40	ppm/°C
Output voltage radiation drift	From 0 krad to 300 krad at 0.55 rad/s	8	ppm/krad
Output voltage radiation drift	From 0 krad to 300 krad, Mil Std 883E Method 1019.6	6	ppm/krad

# 11 Revision history

**Table 8. Document revision history**

Date	Revision	Changes
29-Oct-2004	3	New Order Codes added - Tables 4 and 5.
27-May-2005	4	The Features, Tables 4, 5 and the Figure 1 has been updated. Add the Mechanical Data SOC-16.
08-Jun-2005	5	Mistake on Table 4 (Q.ty Level), Table 7 has been updated and add DIE Information.
30-Jan-2006	6	Added new Package SMD5C and Removed old Package SOC-16.
26-Jan-2007	7	DIE Information and DIE Pad has been updated par. 6, pages 9 and 10.
23-Nov-2007	8	Pin information for the SMD5C package updated in <a href="#">Table 1</a> ; added section <a href="#">6.3: FPGA power supply lines on page 11</a> . Minor text changes.
22-Sep-2008	9	Modified <a href="#">Application information on page 10</a> .
17-Nov-2008	10	Modified <a href="#">Table 6 on page 18</a> .

**Please Read Carefully:**

Information in this document is provided solely in connection with ST products. STMicroelectronics NV and its subsidiaries ("ST") reserve the right to make changes, corrections, modifications or improvements, to this document, and the products and services described herein at any time, without notice.

All ST products are sold pursuant to ST's terms and conditions of sale.

Purchasers are solely responsible for the choice, selection and use of the ST products and services described herein, and ST assumes no liability whatsoever relating to the choice, selection or use of the ST products and services described herein.

No license, express or implied, by estoppel or otherwise, to any intellectual property rights is granted under this document. If any part of this document refers to any third party products or services it shall not be deemed a license grant by ST for the use of such third party products or services, or any intellectual property contained therein or considered as a warranty covering the use in any manner whatsoever of such third party products or services or any intellectual property contained therein.

**UNLESS OTHERWISE SET FORTH IN ST'S TERMS AND CONDITIONS OF SALE ST DISCLAIMS ANY EXPRESS OR IMPLIED WARRANTY WITH RESPECT TO THE USE AND/OR SALE OF ST PRODUCTS INCLUDING WITHOUT LIMITATION IMPLIED WARRANTIES OF MERCHANTABILITY, FITNESS FOR A PARTICULAR PURPOSE (AND THEIR EQUIVALENTS UNDER THE LAWS OF ANY JURISDICTION), OR INFRINGEMENT OF ANY PATENT, COPYRIGHT OR OTHER INTELLECTUAL PROPERTY RIGHT.**

**UNLESS EXPRESSLY APPROVED IN WRITING BY AN AUTHORIZED ST REPRESENTATIVE, ST PRODUCTS ARE NOT RECOMMENDED, AUTHORIZED OR WARRANTED FOR USE IN MILITARY, AIR CRAFT, SPACE, LIFE SAVING, OR LIFE SUSTAINING APPLICATIONS, NOR IN PRODUCTS OR SYSTEMS WHERE FAILURE OR MALFUNCTION MAY RESULT IN PERSONAL INJURY, DEATH, OR SEVERE PROPERTY OR ENVIRONMENTAL DAMAGE. ST PRODUCTS WHICH ARE NOT SPECIFIED AS "AUTOMOTIVE GRADE" MAY ONLY BE USED IN AUTOMOTIVE APPLICATIONS AT USER'S OWN RISK.**

Resale of ST products with provisions different from the statements and/or technical features set forth in this document shall immediately void any warranty granted by ST for the ST product or service described herein and shall not create or extend in any manner whatsoever, any liability of ST.

ST and the ST logo are trademarks or registered trademarks of ST in various countries.

Information in this document supersedes and replaces all information previously supplied.

The ST logo is a registered trademark of STMicroelectronics. All other names are the property of their respective owners.

© 2008 STMicroelectronics - All rights reserved

STMicroelectronics group of companies

Australia - Belgium - Brazil - Canada - China - Czech Republic - Finland - France - Germany - Hong Kong - India - Israel - Italy - Japan - Malaysia - Malta - Morocco - Singapore - Spain - Sweden - Switzerland - United Kingdom - United States of America

[www.st.com](http://www.st.com)