



STD100N10F7, STF100N10F7, STP100N10F7

N-channel 100 V, 0.0068 Ω typ., 80 A, STripFET™ VII DeepGATE™
Power MOSFET in DPAK, TO-220FP and TO-220 packages

Datasheet — preliminary data

Features

Type	V _{DSS}	R _{DS(on)} max	I _D	P _{TOT}
STD100N10F7	100 V	0.008 Ω	80 A	120 W
STF100N10F7			45 A	30 W
STP100N10F7			80A	150 W

- Ultra low on-resistance
- 100% avalanche tested

Applications

- Switching applications

Description

These devices utilize the 7th generation of design rules of ST's proprietary STripFET™ technology, with a new gate structure. The resulting Power MOSFET exhibits the lowest R_{DS(on)} in all packages.

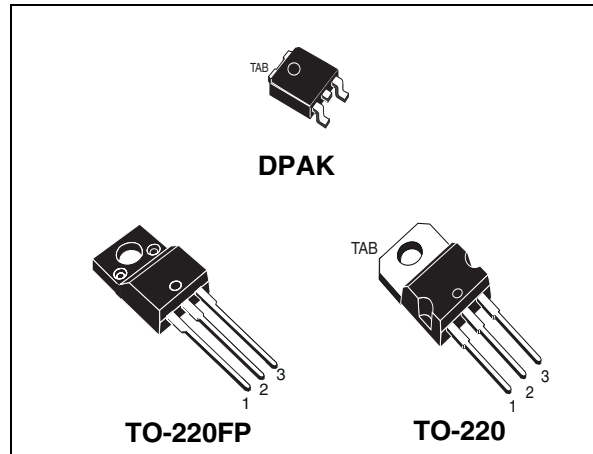
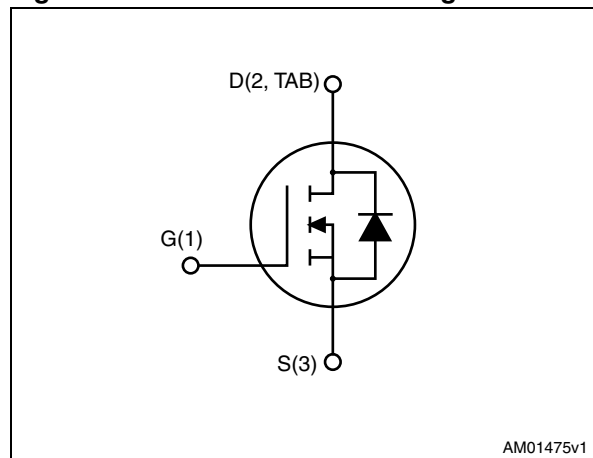

Figure 1. Internal schematic diagram



AM01475v1

Table 1. Device summary

Order codes	Marking	Package	Packaging
STD100N10F7	100N10F7	DPAK	Tape and reel
STF100N10F7		TO-220FP	Tube
STP100N10F7		TO-220	Tube

Contents

1	Electrical ratings	3
2	Electrical characteristics	4
3	Test circuits	6
4	Package mechanical data	7
5	Packaging mechanical data	15
6	Revision history	17

1 Electrical ratings

Table 2. Absolute maximum ratings

Symbol	Parameter	Value			Unit
		DPAK	TO-220FP	TO-220	
V_{DS}	Drain-source voltage	100			V
V_{GS}	Gate-source voltage	± 20			V
$I_D^{(1)}$	Drain current (continuous) at $T_C = 25\text{ }^\circ\text{C}$	80	45	80	A
$I_D^{(1)}$	Drain current (continuous) at $T_C = 100\text{ }^\circ\text{C}$	65	32	70	A
$I_{DM}^{(2)}$	Drain current (pulsed)	320	180	320	A
$P_{TOT}^{(1)}$	Total dissipation at $T_{pcb} = 25\text{ }^\circ\text{C}$	120	30	150	W
T_J T_{stg}	Operating junction temperature Storage temperature	-55 to 175			$^\circ\text{C}$

1. This value is rated according to R_{thj-c} .
2. Pulse width limited by safe operating area.

Table 3. Thermal resistance

Symbol	Parameter	Value			Unit
		DPAK	TO-220FP	TO-220	
$R_{thj-case}$	Thermal resistance junction-case	1.25	5	1.00	$^\circ\text{C}/\text{W}$
$R_{thj-amb}$	Thermal resistance junction-ambient		62.50		$^\circ\text{C}/\text{W}$
$R_{thj-pcb}^{(1)}$	Thermal resistance junction-pcb	50			$^\circ\text{C}/\text{W}$

1. When mounted on FR-4 board of 1inch², 2oz Cu, $t < 10\text{ sec}$

2 Electrical characteristics

($T_{CASE}=25\text{ °C}$ unless otherwise specified)

Table 4. On/off states

Symbol	Parameter	Test conditions	Min.	Typ.	Max.	Unit
$V_{(BR)DSS}$	Drain-source breakdown voltage ($V_{GS}=0$)	$I_D = 250\ \mu\text{A}$	100		-	V
I_{DSS}	Zero gate voltage drain current ($V_{GS}=0$)	$V_{DS} = 100\text{ V}$ $V_{DS} = 100\text{ V}; T_C=125\text{ °C}$			1 100	μA μA
I_{GSS}	Gate body leakage current ($V_{DS}=0$)	$V_{GS} = 20\text{ V}$			100	nA
$V_{GS(th)}$	Gate threshold voltage	$V_{DS}=V_{GS}; I_D = 250\ \mu\text{A}$	2		4	V
$R_{DS(on)}$	Static drain-source on-resistance	For DPAK and TO-220 $V_{GS}= 10\text{ V}, I_D= 50\text{ A}$ For TO-220-FP $V_{GS}= 10\text{ V}, I_D= 22.5\text{ A}$		0.0068	0.008	Ω

Table 5. Dynamic

Symbol	Parameter	Test conditions	Min.	Typ.	Max.	Unit
C_{iss}	Input capacitance	$V_{DS}=25\text{ V}, f=1\text{ MHz}, V_{GS}=0$	-	4390	-	pF
C_{oss}	Output capacitance			1300		pF
C_{rss}	Reverse transfer capacitance			100		pF
Q_g	Total gate charge	$V_{DD}=50\text{ V}, I_D = 100\text{ A}$	-	56	-	nC
Q_{gs}	Gate-source charge	$V_{GS}=10\text{ V}$		13		
Q_{gd}	Gate-drain charge	Figure 3		60		

Table 6. Switching times

Symbol	Parameter	Test conditions	Min.	Typ.	Max.	Unit
$t_{d(on)}$	Turn-on delay time	$V_{DD}=50\text{ V}, I_D= 50\text{ A},$ $R_G=4.7\ \Omega, V_{GS}= 10\text{ V}$ Figure 2	-	27	-	ns
t_r	Rise time			40		ns
$t_{d(off)}$	Turn-off delay time			46		ns
t_f	Fall time			16		ns

Table 7. Source drain diode

Symbol	Parameter	Test conditions	Min	Typ.	Max	Unit
I_{SD}	Source-drain current		-	-	80	A
$I_{SDM}^{(1)}$	Source-drain current (pulsed)		-	-	320	A
$V_{SD}^{(2)}$	Forward on voltage	$I_{SD} = 80 \text{ A}$, $V_{GS} = 0$	1.2	-	-	V
t_{rr}	Reverse recovery time	$I_{SD} = 80 \text{ A}$, $di/dt = 100 \text{ A}/\mu\text{s}$, $V_{DD} = 80 \text{ V}$, $T_j = 150 \text{ }^\circ\text{C}$	-	TBD	-	ns
Q_{rr}	Reverse recovery charge			TBD		nC
I_{RRM}	Reverse recovery current			TBD		A

1. Pulse width limited by safe operating area
2. Pulsed: pulse duration=300 μs , duty cycle 1.5%

3 Test circuits

Figure 2. Switching times test circuit for resistive load

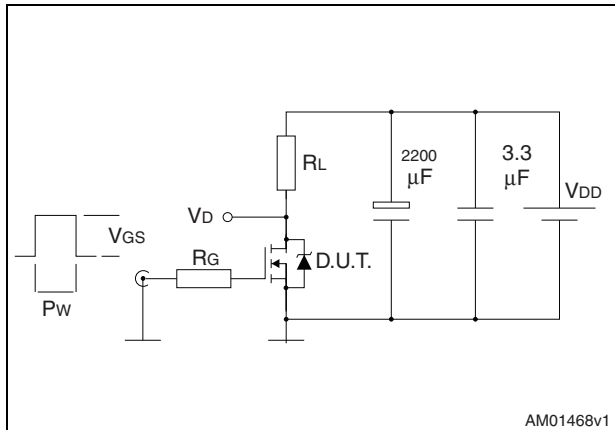

AM01468v1

Figure 3. Gate charge test circuit

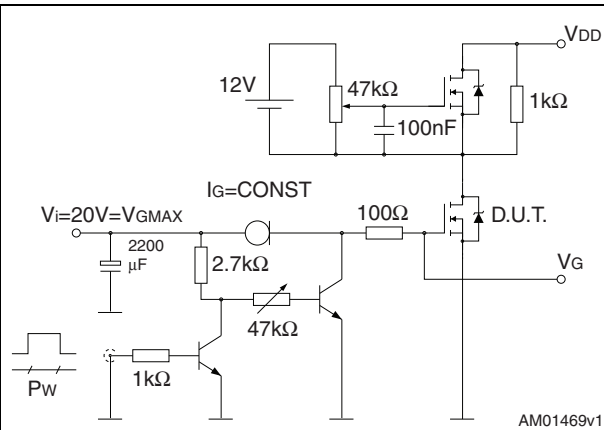

AM01469v1

Figure 4. Test circuit for inductive load switching and diode recovery times

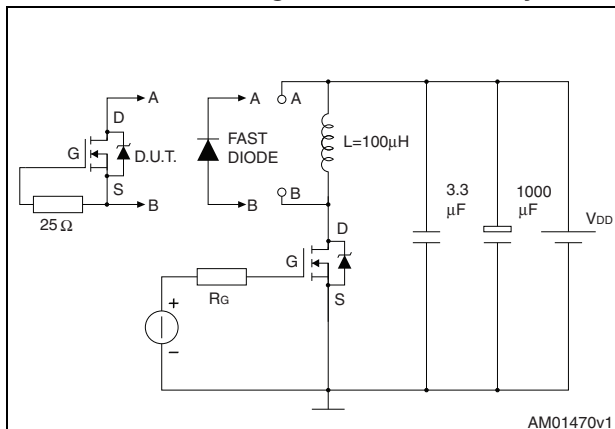

AM01470v1

Figure 5. Unclamped inductive load test circuit

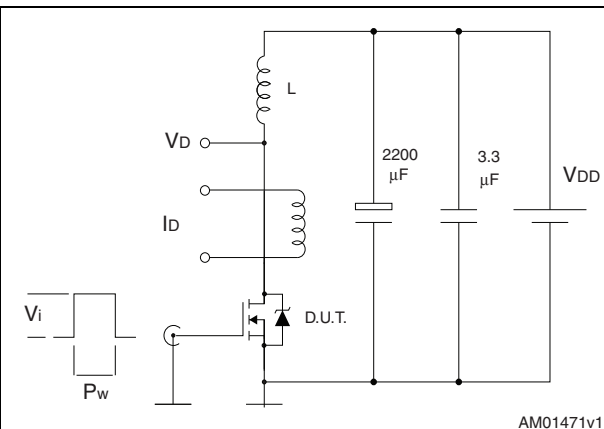

AM01471v1

Figure 6. Unclamped inductive waveform

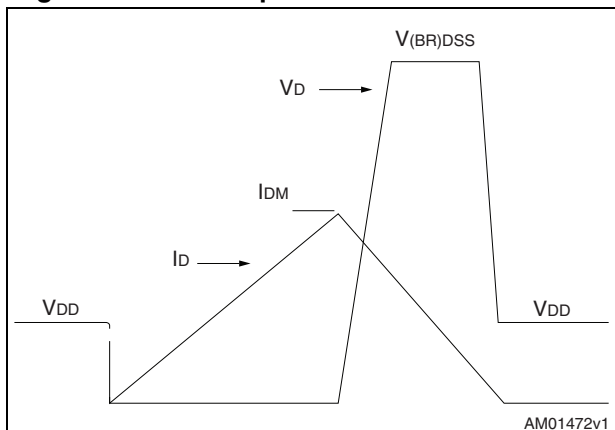

AM01472v1

Figure 7. Switching time waveform

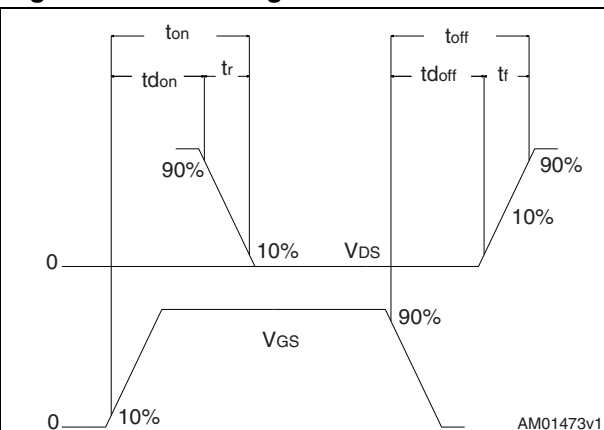

AM01473v1

4 Package mechanical data

In order to meet environmental requirements, ST offers these devices in different grades of ECOPACK[®] packages, depending on their level of environmental compliance. ECOPACK[®] specifications, grade definitions and product status are available at: www.st.com. ECOPACK[®] is an ST trademark.

Table 8. DPAK (TO-252) mechanical data

Dim.	mm		
	Min.	Typ.	Max.
A	2.20		2.40
A1	0.90		1.10
A2	0.03		0.23
b	0.64		0.90
b4	5.20		5.40
c	0.45		0.60
c2	0.48		0.60
D	6.00		6.20
D1		5.10	
E	6.40		6.60
E1		4.70	
e		2.28	
e1	4.40		4.60
H	9.35		10.10
L	1.00		1.50
(L1)		2.80	
L2		0.80	
L4	0.60		1.00
R		0.20	
V2	0°		8°

Figure 8. DPAK (TO-252) drawing

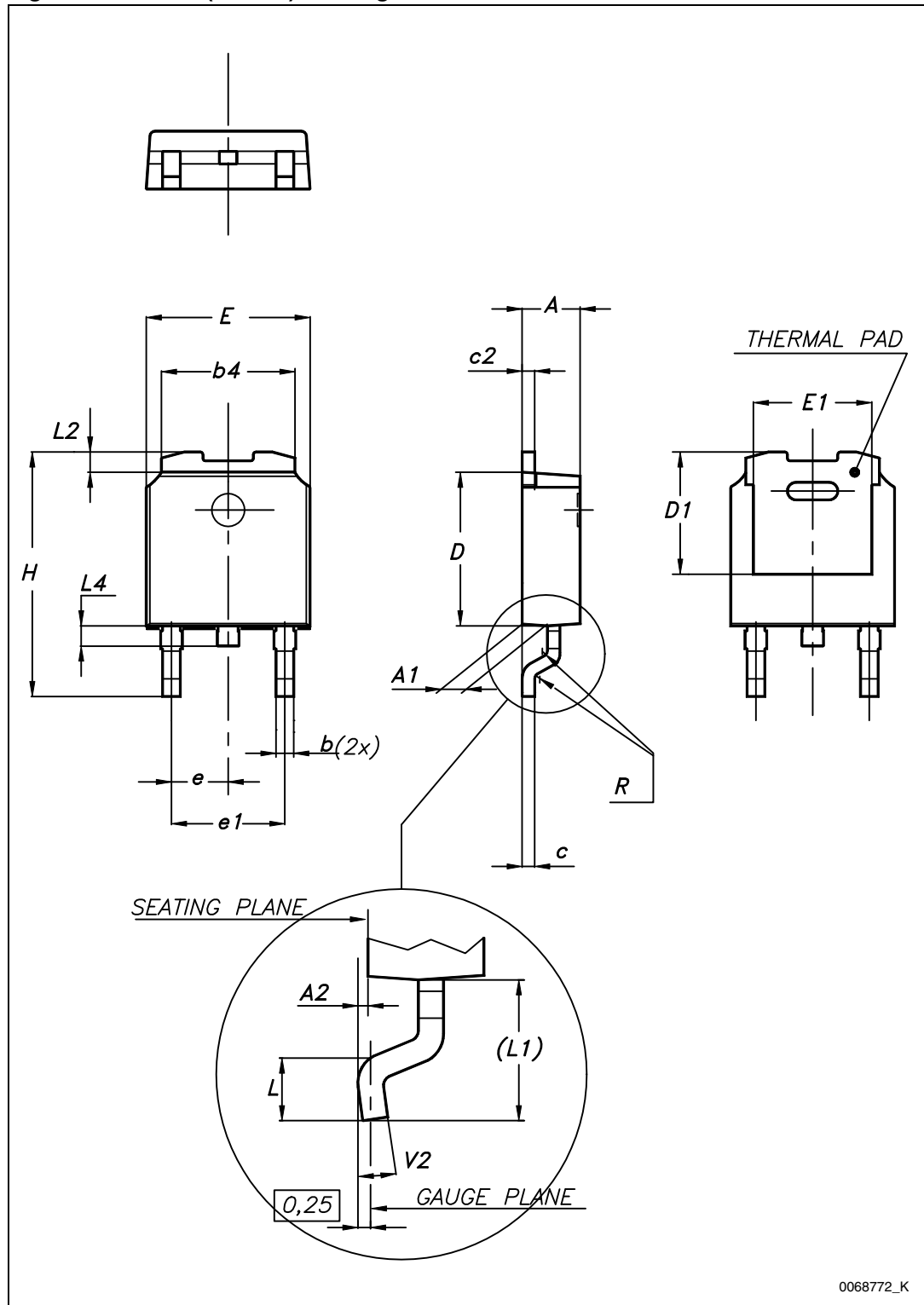
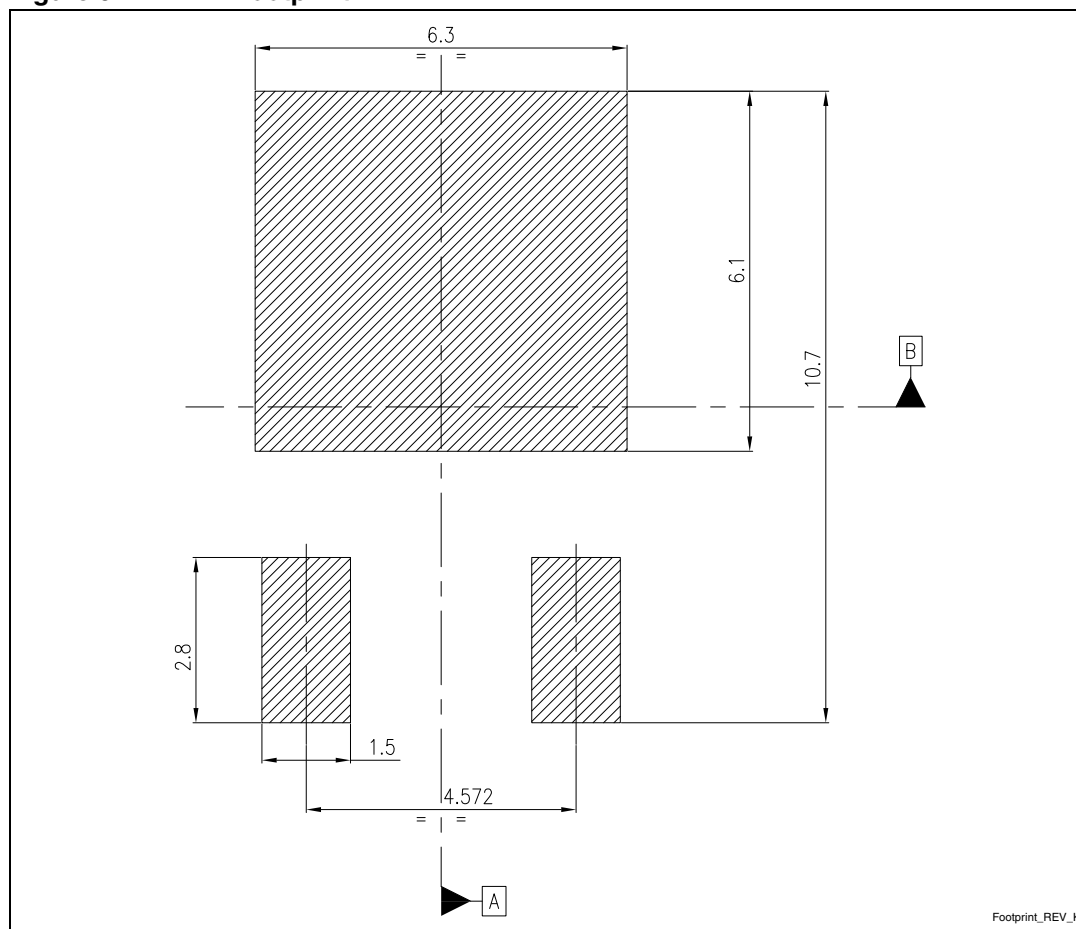

Figure 9. DPAK footprint (a)



a. All dimensions are in millimeters

Table 9. TO-220FP mechanical data

Dim.	mm		
	Min.	Typ.	Max.
A	4.4		4.6
B	2.5		2.7
D	2.5		2.75
E	0.45		0.7
F	0.75		1
F1	1.15		1.70
F2	1.15		1.70
G	4.95		5.2
G1	2.4		2.7
H	10		10.4
L2		16	
L3	28.6		30.6
L4	9.8		10.6
L5	2.9		3.6
L6	15.9		16.4
L7	9		9.3
Dia	3		3.2

Figure 10. TO-220FP drawing

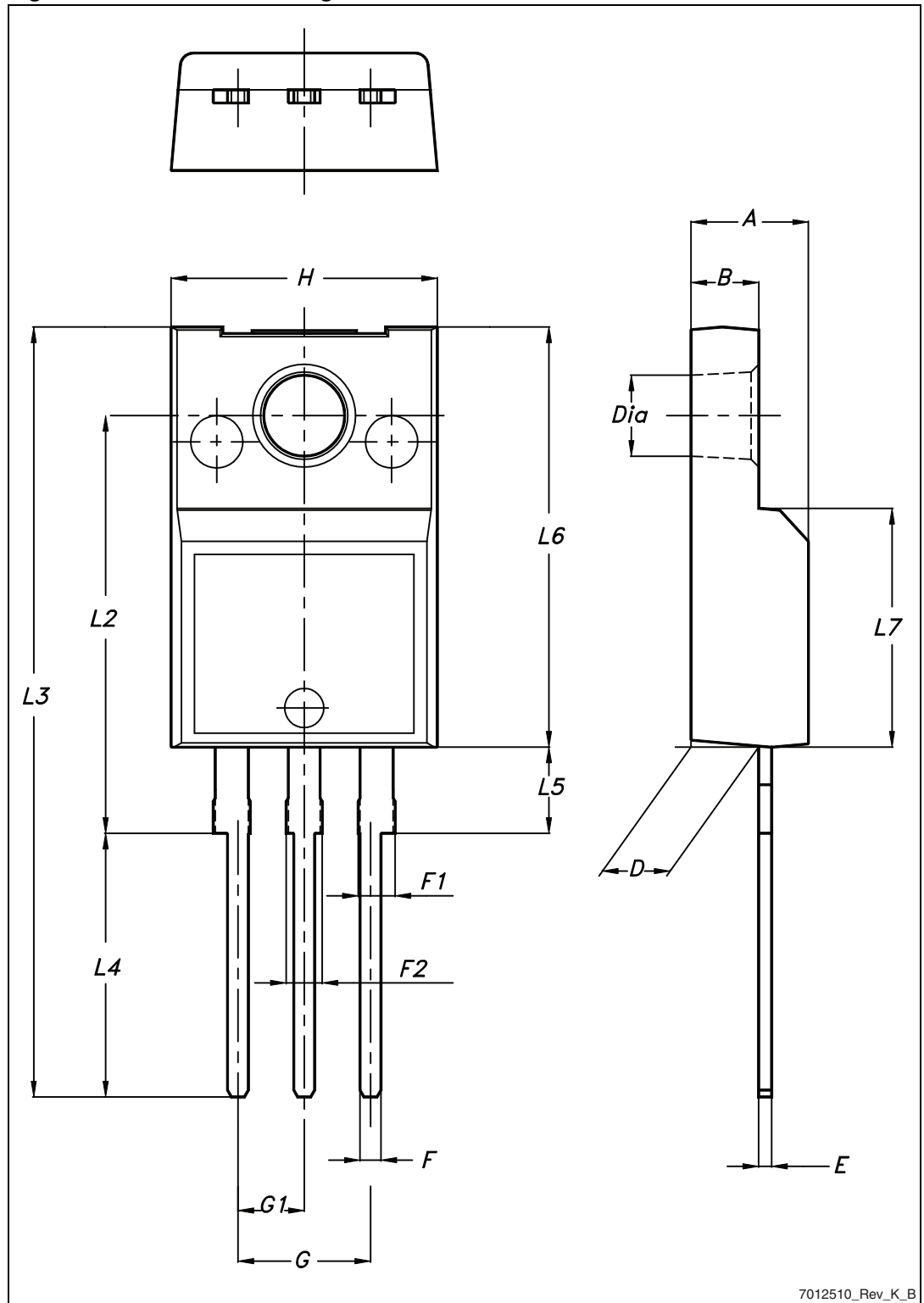

7012510_Rev_K_B

Table 10. TO-220 type A mechanical data

Dim.	mm		
	Min.	Typ.	Max.
A	4.40		4.60
b	0.61		0.88
b1	1.14		1.70
c	0.48		0.70
D	15.25		15.75
D1		1.27	
E	10		10.40
e	2.40		2.70
e1	4.95		5.15
F	1.23		1.32
H1	6.20		6.60
J1	2.40		2.72
L	13		14
L1	3.50		3.93
L20		16.40	
L30		28.90	
ØP	3.75		3.85
Q	2.65		2.95

Figure 11. TO-220 type A drawing

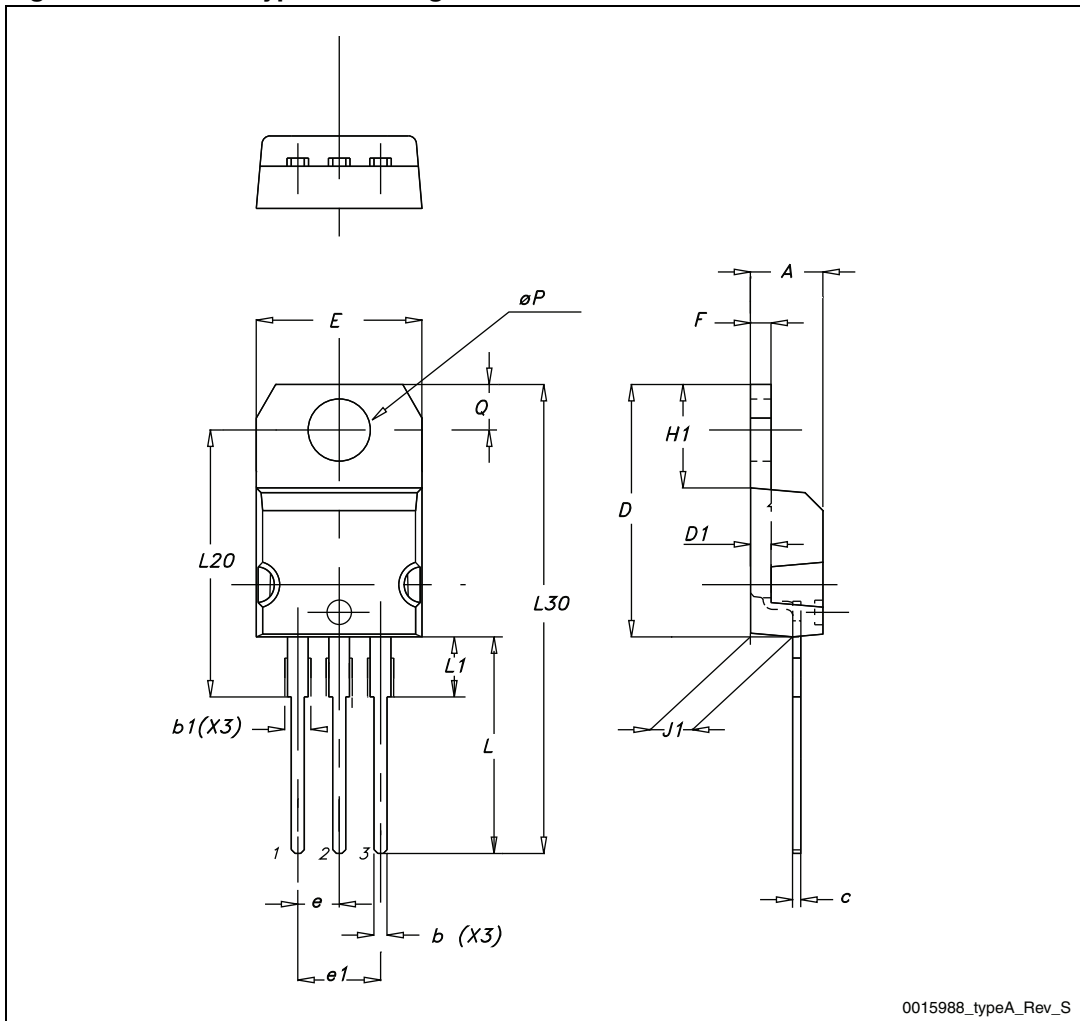

5 Packaging mechanical data

Table 11. DPAK (TO-252) tape and reel mechanical data

Tape			Reel		
Dim.	mm		Dim.	mm	
	Min.	Max.		Min.	Max.
A0	6.8	7	A		330
B0	10.4	10.6	B	1.5	
B1		12.1	C	12.8	13.2
D	1.5	1.6	D	20.2	
D1	1.5		G	16.4	18.4
E	1.65	1.85	N	50	
F	7.4	7.6	T		22.4
K0	2.55	2.75			
P0	3.9	4.1	Base qty.		2500
P1	7.9	8.1	Bulk qty.		2500
P2	1.9	2.1			
R	40				
T	0.25	0.35			
W	15.7	16.3			

Figure 12. Tape for DPAK (TO-252)

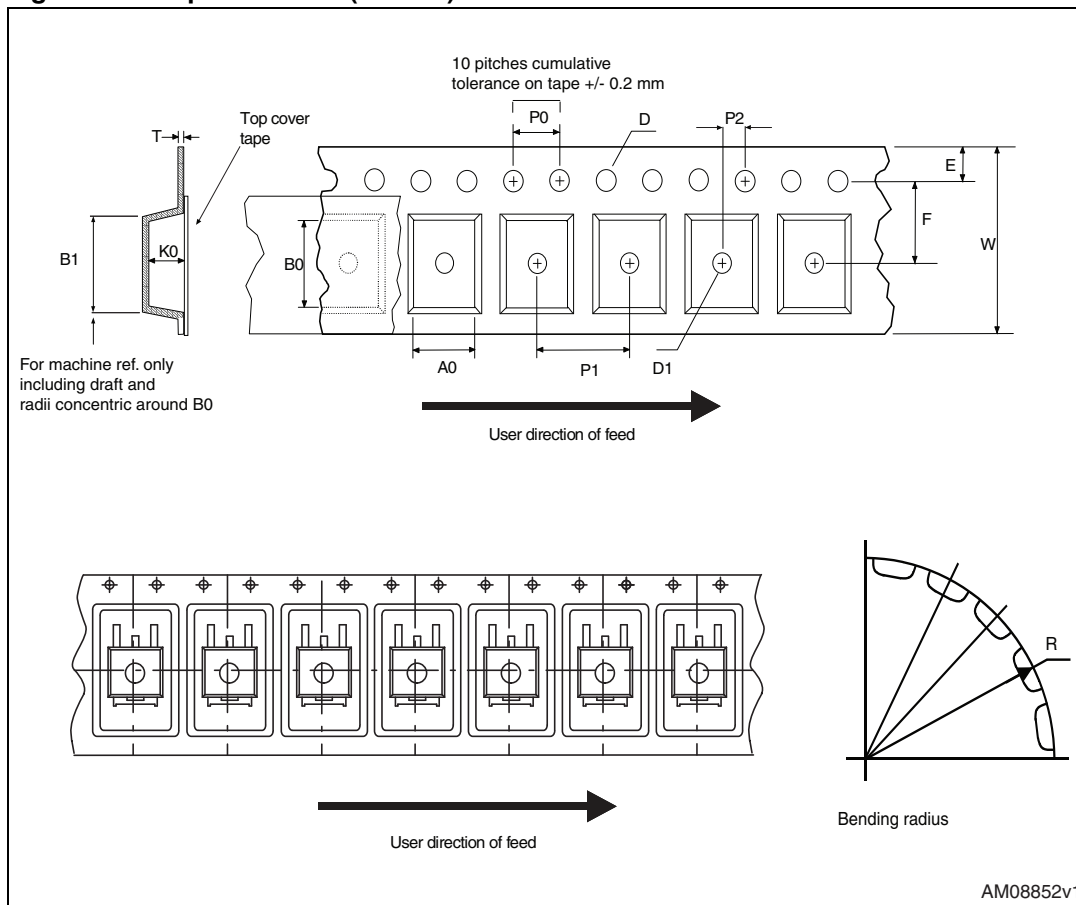
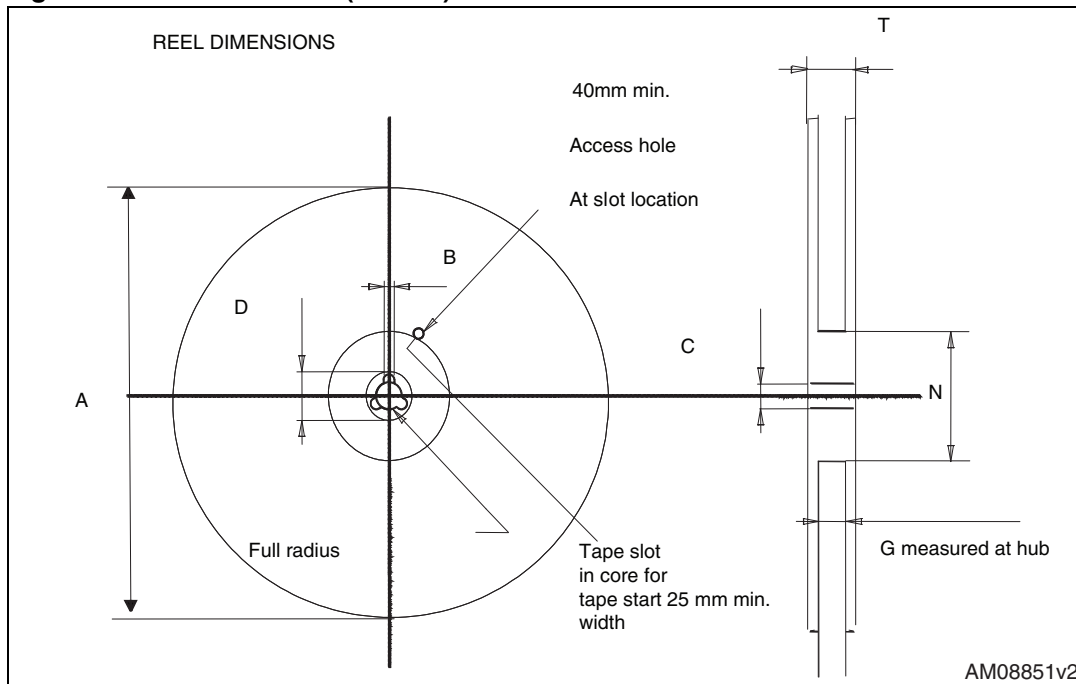

Figure 13. Reel for DPAK (TO-252)



6 Revision history

Table 12. Document revision history

Date	Revision	Changes
05-Oct-2012	1	First release.
07-Feb-2013	2	<ul style="list-style-type: none">– Inserted device in TO-220FP.– Updated title and features on the cover page, Table 1: Device summary, Table 2: Absolute maximum ratings, Table 3: Thermal resistance and Table 4: On/off states accordingly.– Updated Table 5: Dynamic, Table 6: Switching times, Table 7: Source drain diode and Section 4: Package mechanical data.– Added Section 5: Packaging mechanical data.

Please Read Carefully:

Information in this document is provided solely in connection with ST products. STMicroelectronics NV and its subsidiaries ("ST") reserve the right to make changes, corrections, modifications or improvements, to this document, and the products and services described herein at any time, without notice.

All ST products are sold pursuant to ST's terms and conditions of sale.

Purchasers are solely responsible for the choice, selection and use of the ST products and services described herein, and ST assumes no liability whatsoever relating to the choice, selection or use of the ST products and services described herein.

No license, express or implied, by estoppel or otherwise, to any intellectual property rights is granted under this document. If any part of this document refers to any third party products or services it shall not be deemed a license grant by ST for the use of such third party products or services, or any intellectual property contained therein or considered as a warranty covering the use in any manner whatsoever of such third party products or services or any intellectual property contained therein.

UNLESS OTHERWISE SET FORTH IN ST'S TERMS AND CONDITIONS OF SALE ST DISCLAIMS ANY EXPRESS OR IMPLIED WARRANTY WITH RESPECT TO THE USE AND/OR SALE OF ST PRODUCTS INCLUDING WITHOUT LIMITATION IMPLIED WARRANTIES OF MERCHANTABILITY, FITNESS FOR A PARTICULAR PURPOSE (AND THEIR EQUIVALENTS UNDER THE LAWS OF ANY JURISDICTION), OR INFRINGEMENT OF ANY PATENT, COPYRIGHT OR OTHER INTELLECTUAL PROPERTY RIGHT.

UNLESS EXPRESSLY APPROVED IN WRITING BY TWO AUTHORIZED ST REPRESENTATIVES, ST PRODUCTS ARE NOT RECOMMENDED, AUTHORIZED OR WARRANTED FOR USE IN MILITARY, AIR CRAFT, SPACE, LIFE SAVING, OR LIFE SUSTAINING APPLICATIONS, NOR IN PRODUCTS OR SYSTEMS WHERE FAILURE OR MALFUNCTION MAY RESULT IN PERSONAL INJURY, DEATH, OR SEVERE PROPERTY OR ENVIRONMENTAL DAMAGE. ST PRODUCTS WHICH ARE NOT SPECIFIED AS "AUTOMOTIVE GRADE" MAY ONLY BE USED IN AUTOMOTIVE APPLICATIONS AT USER'S OWN RISK.

Resale of ST products with provisions different from the statements and/or technical features set forth in this document shall immediately void any warranty granted by ST for the ST product or service described herein and shall not create or extend in any manner whatsoever, any liability of ST.

ST and the ST logo are trademarks or registered trademarks of ST in various countries.

Information in this document supersedes and replaces all information previously supplied.

The ST logo is a registered trademark of STMicroelectronics. All other names are the property of their respective owners.

© 2013 STMicroelectronics - All rights reserved

STMicroelectronics group of companies

Australia - Belgium - Brazil - Canada - China - Czech Republic - Finland - France - Germany - Hong Kong - India - Israel - Italy - Japan - Malaysia - Malta - Morocco - Philippines - Singapore - Spain - Sweden - Switzerland - United Kingdom - United States of America

www.st.com