



STD36NH02L

N-channel 24V - 0.011 Ω - 30A - DPAK
STripFET™ III Power MOSFET

General features

Type	V _{DSS}	R _{DS(on)}	I _D
STD36NH02L	24V	<0.0145 Ω	30A ⁽¹⁾

1. Guaranteed when external R_g=4.7 Ω and t_r < t_{rmax}

- R_{DS(on)} * Q_g industry's benchmark
- Conduction losses reduced
- Switching losses reduced

Description

This series of products utilizes the last advanced design rules of ST's proprietary STripFET™ technology. This is suitable for the most demanding DC-DC converter application where high efficiency is to be achieved.

Applications

- Switching application

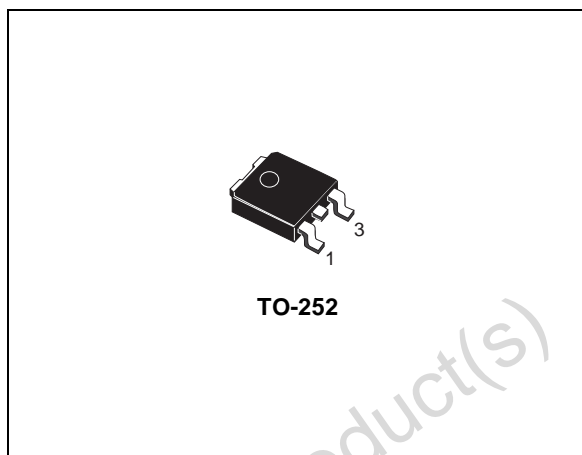

Internal schematic diagram

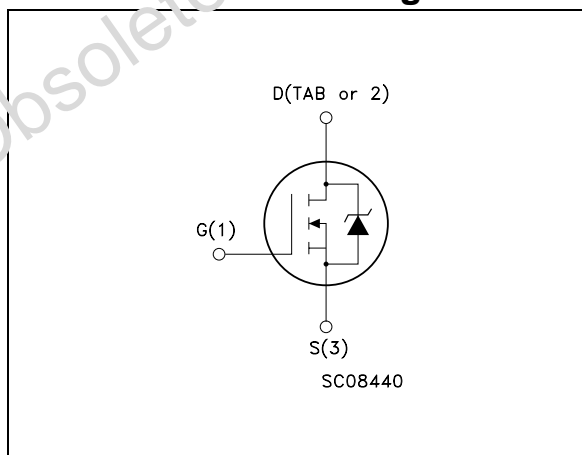

Order codes

Part number	Marking	Package	Packaging
STD36NH02L	D36NH02L	DPAK	Tape & reel

Contents

1	Electrical ratings	3
2	Electrical characteristics	4
	2.1 Electrical characteristics (curves)	6
3	Test circuit	8
4	Package mechanical data	9
5	Packaging mechanical data	11
6	Revision history	12

Obsolete Product(s) - Obsolete Product(s)

1 Electrical ratings

Table 1. Absolute maximum ratings

Symbol	Parameter	Value	Unit
$V_{\text{spike}}^{(1)}$	Drain-source voltage rating	30	V
V_{DS}	Drain-Source Voltage ($V_{\text{GS}} = 0$)	24	V
V_{GS}	Gate-Source Voltage	± 20	V
$I_{\text{D}}^{(2)}$	Drain Current (continuous) at $T_{\text{C}} = 25^{\circ}\text{C}$	30	A
I_{D}	Drain Current (continuous) at $T_{\text{C}}=100^{\circ}\text{C}$	30	A
$I_{\text{DM}}^{(3)}$	Drain Current (pulsed)	120	A
P_{TOT}	Total Dissipation at $T_{\text{C}} = 25^{\circ}\text{C}$	45	W
	Derating Factor	0.27	W/ $^{\circ}\text{C}$
$E_{\text{AS}}^{(4)}$	Single pulse avalanche energy	200	mJ
T_{J} T_{stg}	Operating Junction Temperature Storage Temperature	-55 to 175	$^{\circ}\text{C}$

1. Guaranteed when external $R_{\text{g}}=4.7\Omega$ and $t_{\text{r}} < t_{\text{fmax}}$
2. Value limited by wire bonding
3. Pulse width limited by safe operating area.
4. Starting $T_{\text{j}}=25^{\circ}\text{C}$, $I_{\text{D}}=19\text{A}$, $V_{\text{DD}}=18\text{V}$

Table 2. Thermal resistance

Symbol	Parameter	Value	Unit
$R_{\text{thj-case}}$	Thermal resistance junction-case Max	3.33	$^{\circ}\text{C}/\text{W}$
$R_{\text{thj-amb}}$	Thermal resistance junction-ambient Max	100	$^{\circ}\text{C}/\text{W}$
T_{l}	Maximum lead temperature for soldering purpose	275	$^{\circ}\text{C}$

2 Electrical characteristics

($T_{CASE}=25^{\circ}C$ unless otherwise specified)

Table 3. On/off states

Symbol	Parameter	Test conditions	Min.	Typ.	Max.	Unit
$V_{(BR)DSS}$	Drain-source breakdown voltage	$I_D = 1mA, V_{GS} = 0$	24			V
I_{DSS}	Zero gate voltage drain current ($V_{GS} = 0$)	$V_{DS} = 20V,$ $V_{DS} = 20V @ 125^{\circ}C$			1 10	μA μA
I_{GSS}	Gate body leakage current ($V_{DS} = 0$)	$V_{GS} = \pm 20V$			± 100	nA
$V_{GS(th)}$	Gate Threshold Voltage	$V_{DS} = V_{GS}, I_D = 250\mu A$	1	1.8	2.5	V
$R_{DS(on)}$	Static Drain-Source On Resistance	$V_{GS} = 10V, I_D = 15A$ $V_{GS} = 5V, I_D = 15A$		0.011 0.013	0.0145 0.026	Ω Ω

Table 4. Dynamic

Symbol	Parameter	Test conditions	Min.	Typ.	Max.	Unit
$g_{fs}^{(1)}$	Forward transconductance	$V_{DS} = 10V, I_D = 15A$		18		S
C_{iss}	Input capacitance	$V_{DS} = 15V, f = 1 MHz,$ $V_{GS} = 0$		860		pF
C_{oss}	Output Capacitance			255		pF
C_{rss}	Reverse transfer capacitance			45		pF
Q_g	Total gate charge	$0.44V \leq V_{DD} \leq 10V,$ $I_D = 30A, V_{GS} = 10V$ (see Figure 14)		15.5	20	nC
Q_{gs}	Gate-source charge			4.1		nC
Q_{gd}	Gate-drain charge			1.7		nC
$Q_{OSS}^{(2)}$	Output charge	$V_{DS} = 16V, V_{GS} = 0$		6		ns
R_G	Gate input resistance	$f = 1 MHz$ Gate DC Bias = 0 Test signal level = 20mV open drain		3		Ω

1. Pulsed: pulse duration=300 μs , duty cycle 1.5%

2. $Q_{OSS} = C_{OSS} * \Delta V_{IN}, C_{OSS} = C_{gd} + C_{ds}$

Table 5. Switching times

Symbol	Parameter	Test conditions	Min	Typ.	Max	Unit
$t_{d(on)}$	Turn-on delay time	$V_{DD}=10V, I_D=15A,$ $R_G=4.7\Omega, V_{GS}=10V$ (see Figure 13)		8		ns
t_r	Rise time			70		ns
$t_{d(off)}$	Turn-off delay time			22		ns
t_f	Fall time			15		ns

Table 6. Source drain diode

Symbol	Parameter	Test conditions	Min	Typ.	Max	Unit
I_{SD}	Source-drain current				30	A
$I_{SDM}^{(1)}$	Source-drain current (pulsed)				120	A
$V_{SD}^{(2)}$	Forward on voltage	$I_{SD} = 15A, V_{GS} = 0$			1.5	V
t_{rr}	Reverse recovery time	$I_{SD} = 30A, di/dt = 100A/\mu s,$ $V_{DD}=15V, T_J=150^\circ C$ (see Figure 15)		24		ns
Q_{rr}	Reverse recovery charge			16		nC
I_{RRM}	Reverse recovery current			1.3		A

1. Pulse width limited by safe operating area
2. Pulsed: pulse duration=300 μs , duty cycle 1.5%

2.1 Electrical characteristics (curves)

Figure 1. Safe operating area

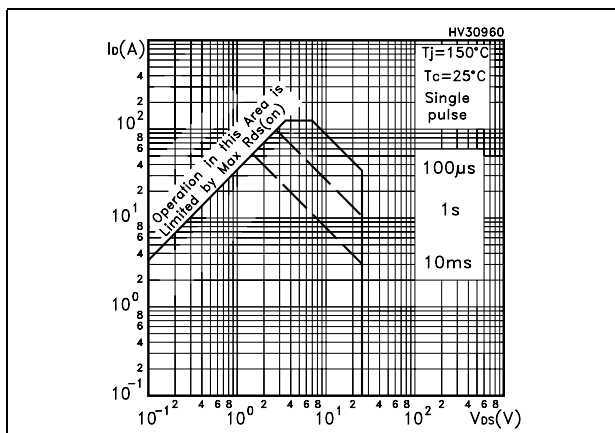

Figure 2. Thermal impedance

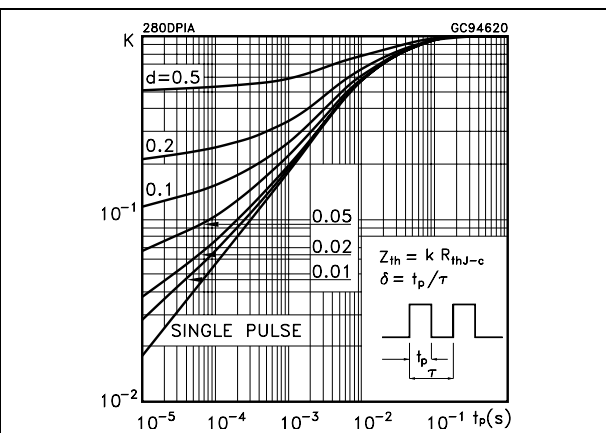

Figure 3. Output characteristics

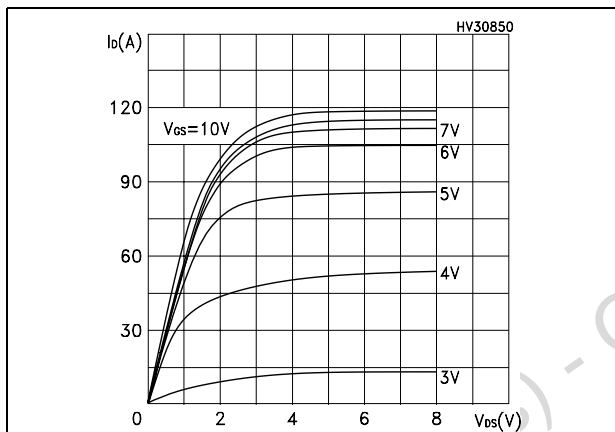

Figure 4. Transfer characteristics

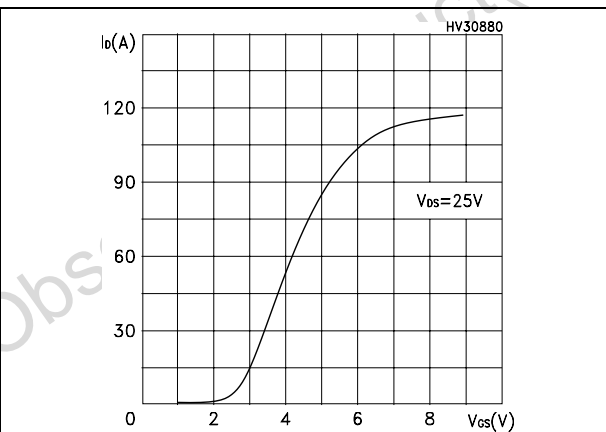

Figure 5. Transconductance

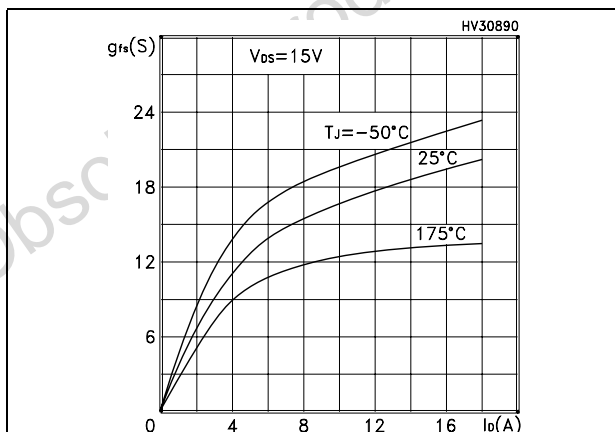

Figure 6. Static drain-source on resistance

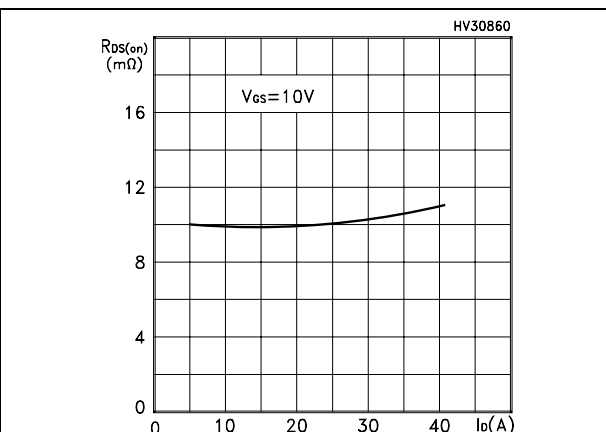

Figure 7. Gate charge vs gate-source voltage Figure 8. Capacitance variations

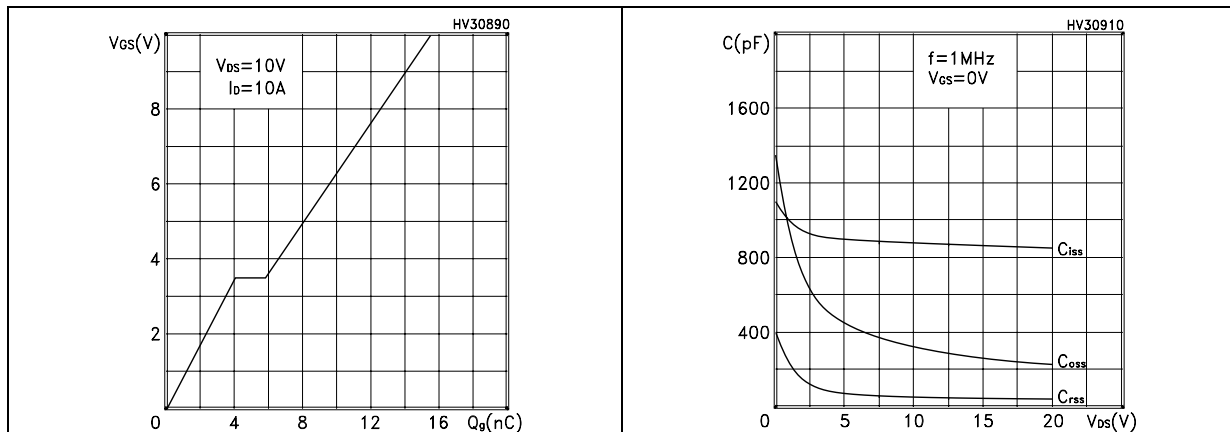

Figure 9. Normalized gate threshold voltage vs temperature Figure 10. Normalized on resistance vs temperature

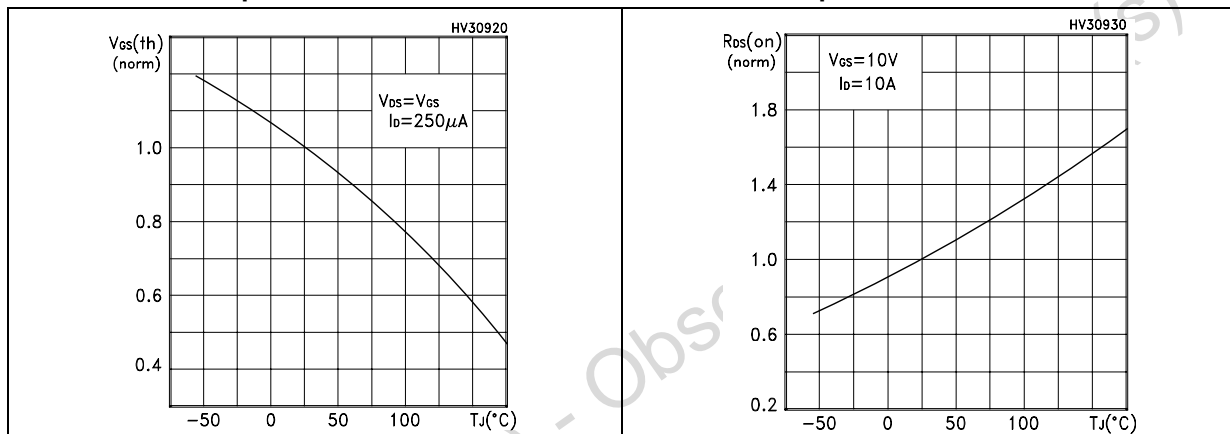
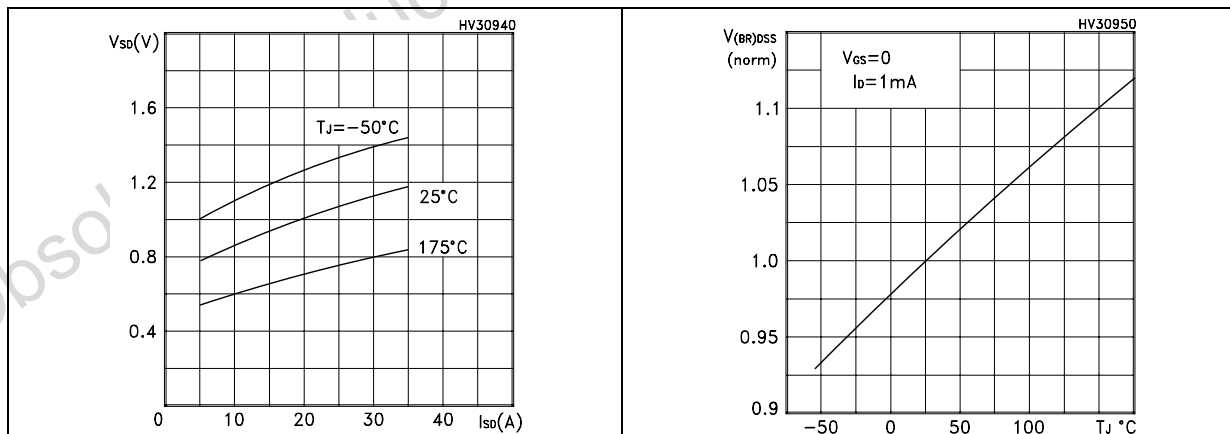

Figure 11. Source-drain diode forward characteristics Figure 12. Normalized B_{VDS} vs temperature



3 Test circuit

Figure 13. Switching times test circuit for resistive load

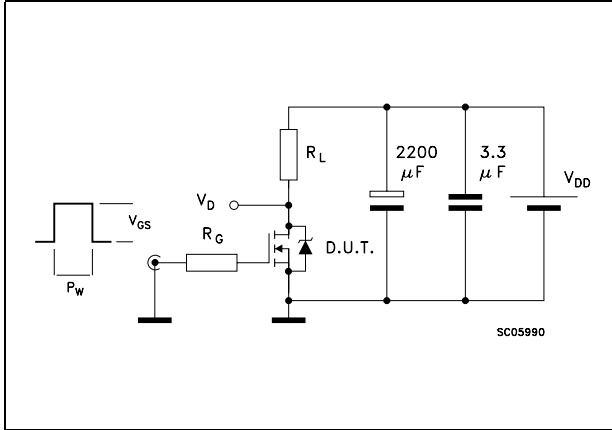

Figure 14. Gate charge test circuit

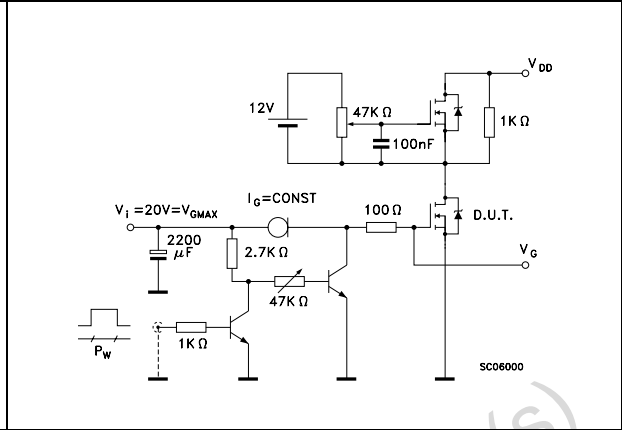

Figure 15. Test circuit for inductive load switching and diode recovery times

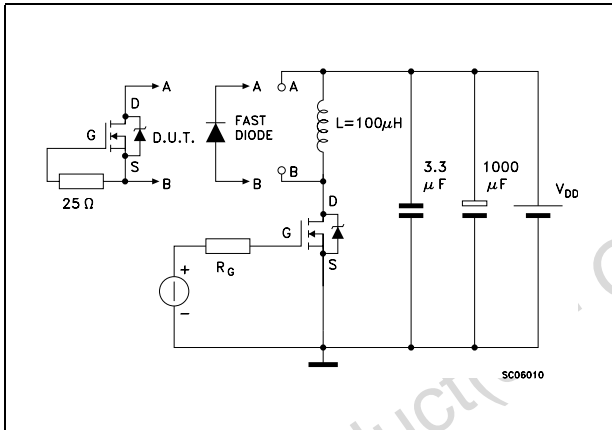

Figure 16. Unclamped inductive load test circuit

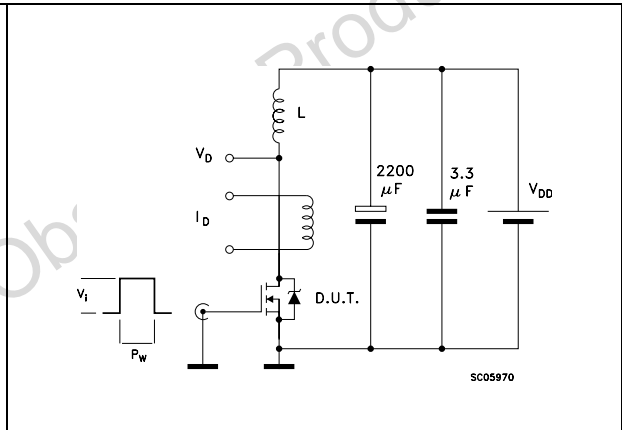

Figure 17. Unclamped inductive waveform

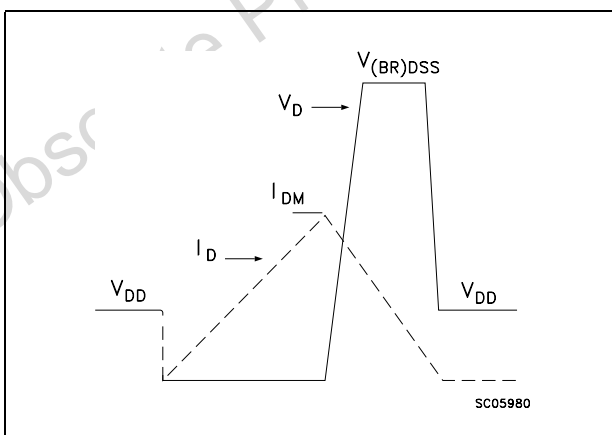
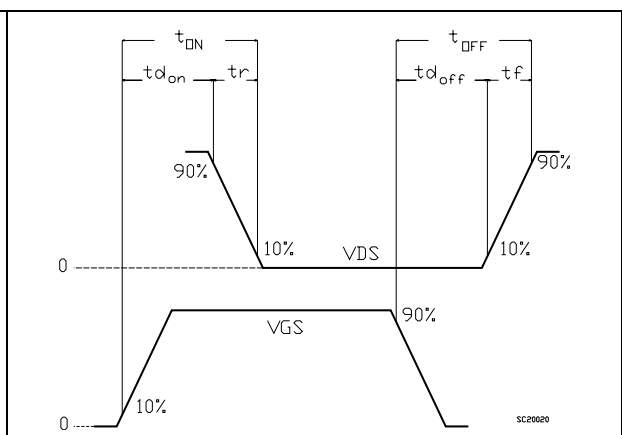

Figure 18. Switching time waveform



4 Package mechanical data

In order to meet environmental requirements, ST offers these devices in ECOPACK® packages. These packages have a Lead-free second level interconnect . The category of second level interconnect is marked on the package and on the inner box label, in compliance with JEDEC Standard JESD97. The maximum ratings related to soldering conditions are also marked on the inner box label. ECOPACK is an ST trademark. ECOPACK specifications are available at: www.st.com

Obsolete Product(s) - Obsolete Product(s)

DPAK MECHANICAL DATA

DIM.	mm.			inch		
	MIN.	TYP.	MAX.	MIN.	TYP.	MAX.
A	2.2		2.4	0.086		0.094
A1	0.9		1.1	0.035		0.043
A2	0.03		0.23	0.001		0.009
B	0.64		0.9	0.025		0.035
b4	5.2		5.4	0.204		0.212
C	0.45		0.6	0.017		0.023
C2	0.48		0.6	0.019		0.023
D	6		6.2	0.236		0.244
D1		5.1			0.200	
E	6.4		6.6	0.252		0.260
E1		4.7			0.185	
e		2.28			0.090	
e1	4.4		4.6	0.173		0.181
H	9.35		10.1	0.368		0.397
L	1			0.039		
(L1)		2.8			0.110	
L2		0.8			0.031	
L4	0.6		1	0.023		0.039
R		0.2			0.008	
V2	0°		8°	0°		8°

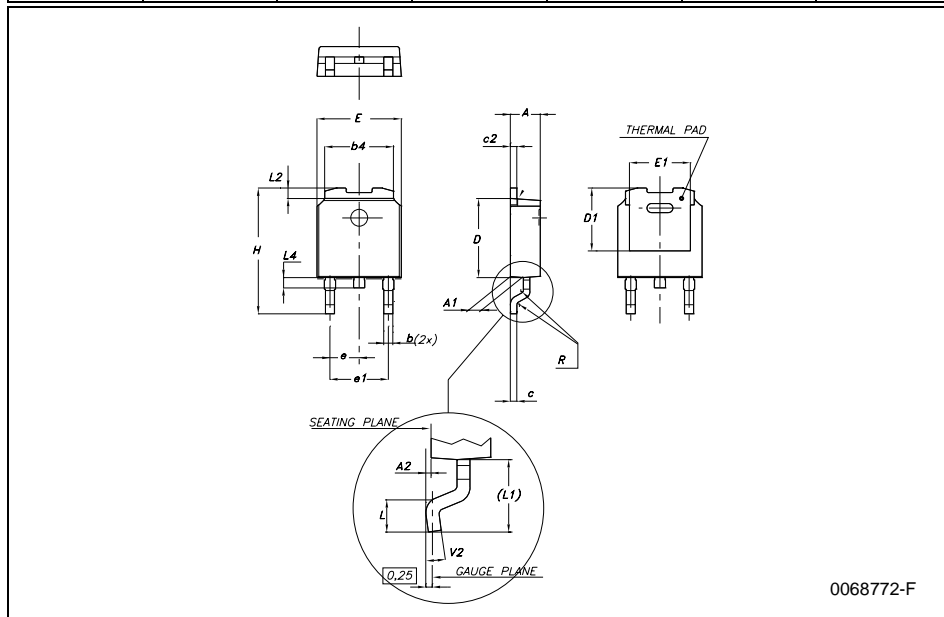

0068772-F

5 Packaging mechanical data

DPAK FOOTPRINT

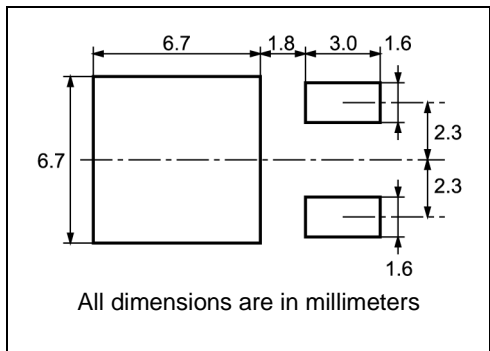

TAPE AND REEL SHIPMENT

40 mm min. Access hole at slot location

Full radius

Tape slot in core for tape start 2.5mm min. width

G measured at hub

DIM.	mm		inch	
	MIN.	MAX.	MIN.	MAX.
A		330		12.992
B	1.5		0.059	
C	12.8	13.2	0.504	0.520
D	20.2		0.795	
G	16.4	18.4	0.645	0.724
N	50		1.968	
T		22.4		0.881

BASE QTY	BULK QTY
2500	2500

DIM.	mm		inch	
	MIN.	MAX.	MIN.	MAX.
A0	6.8	7	0.267	0.275
B0	10.4	10.6	0.409	0.417
B1		12.1		0.476
D	1.5	1.6	0.059	0.063
D1	1.5		0.059	
E	1.65	1.85	0.065	0.073
F	7.4	7.6	0.291	0.299
K0	2.55	2.75	0.100	0.108
P0	3.9	4.1	0.153	0.161
P1	7.9	8.1	0.311	0.319
P2	1.9	2.1	0.075	0.082
R	40		1.574	
W	15.7	16.3	0.618	0.641

TOP COVER TAPE

User Direction of Feed

Center line of cavity

Bending radius

R min.

FEED DIRECTION

For machine ref. only including draft and radii concentric around B0

10 pitches cumulative tolerance on tape +/- 0.2 mm

6 Revision history

Table 7. Revision history

Date	Revision	Changes
27-Apr-2006	1	First Release

Obsolete Product(s) - Obsolete Product(s)

Please Read Carefully:

Information in this document is provided solely in connection with ST products. STMicroelectronics NV and its subsidiaries ("ST") reserve the right to make changes, corrections, modifications or improvements, to this document, and the products and services described herein at any time, without notice.

All ST products are sold pursuant to ST's terms and conditions of sale.

Purchasers are solely responsible for the choice, selection and use of the ST products and services described herein, and ST assumes no liability whatsoever relating to the choice, selection or use of the ST products and services described herein.

No license, express or implied, by estoppel or otherwise, to any intellectual property rights is granted under this document. If any part of this document refers to any third party products or services it shall not be deemed a license grant by ST for the use of such third party products or services, or any intellectual property contained therein or considered as a warranty covering the use in any manner whatsoever of such third party products or services or any intellectual property contained therein.

UNLESS OTHERWISE SET FORTH IN ST'S TERMS AND CONDITIONS OF SALE ST DISCLAIMS ANY EXPRESS OR IMPLIED WARRANTY WITH RESPECT TO THE USE AND/OR SALE OF ST PRODUCTS INCLUDING WITHOUT LIMITATION IMPLIED WARRANTIES OF MERCHANTABILITY, FITNESS FOR A PARTICULAR PURPOSE (AND THEIR EQUIVALENTS UNDER THE LAWS OF ANY JURISDICTION), OR INFRINGEMENT OF ANY PATENT, COPYRIGHT OR OTHER INTELLECTUAL PROPERTY RIGHT.

UNLESS EXPRESSLY APPROVED IN WRITING BY AN AUTHORIZED REPRESENTATIVE OF ST, ST PRODUCTS ARE NOT DESIGNED, AUTHORIZED OR WARRANTED FOR USE IN MILITARY, AIR CRAFT, SPACE, LIFE SAVING, OR LIFE SUSTAINING APPLICATIONS, NOR IN PRODUCTS OR SYSTEMS, WHERE FAILURE OR MALFUNCTION MAY RESULT IN PERSONAL INJURY, DEATH, OR SEVERE PROPERTY OR ENVIRONMENTAL DAMAGE.

Resale of ST products with provisions different from the statements and/or technical features set forth in this document shall immediately void any warranty granted by ST for the ST product or service described herein and shall not create or extend in any manner whatsoever, any liability of ST.

ST and the ST logo are trademarks or registered trademarks of ST in various countries.

Information in this document supersedes and replaces all information previously supplied.

The ST logo is a registered trademark of STMicroelectronics. All other names are the property of their respective owners.

© 2006 STMicroelectronics - All rights reserved

STMicroelectronics group of companies

Australia - Belgium - Brazil - Canada - China - Czech Republic - Finland - France - Germany - Hong Kong - India - Israel - Italy - Japan - Malaysia - Malta - Morocco - Singapore - Spain - Sweden - Switzerland - United Kingdom - United States of America

www.st.com

