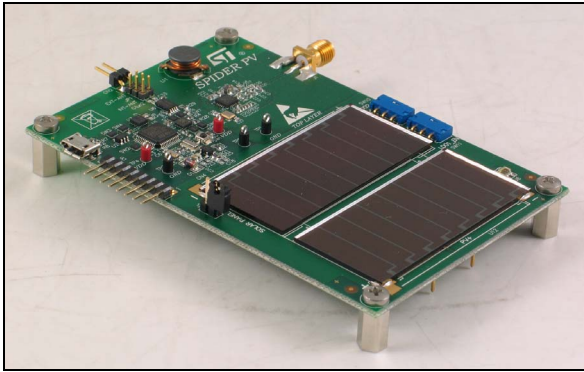


Autonomous wireless multi-sensor node powered by PV cells and based on SPV1050 (SPIDER™)

Data brief



Features

- Autonomous wireless sensor node based on ULP energy harvester and battery charger SPV1050
- Typical use case with 3-axis accelerometer, temperature sensor and air pressure sensor on board
- PV module soldered on top
- Lithium coin-cell battery
- User-friendly software GUI for system configuration
- It can be used with power monitoring board for efficiency and all fundamental electrical parameters measurement
- RF receiver board powered by USB
- All ST component offer

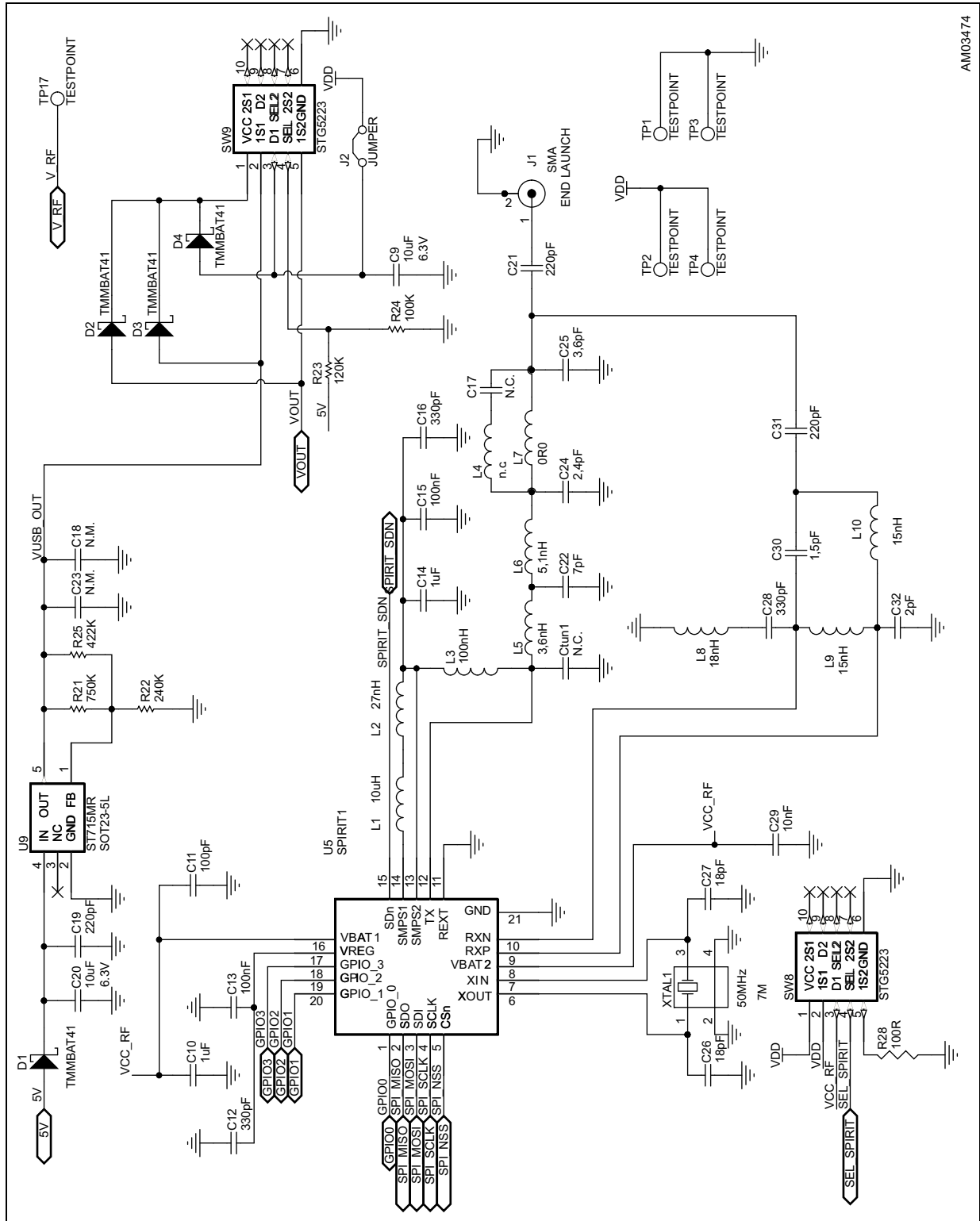
Description

The STEVAL-IDS002V1 device is a complete fully configurable energy reference design wireless sensor node powered by a photovoltaic module soldered on the top. It is composed by a fully integrated transmitter board which contains a temperature sensor, an air pressure sensor and a 3-axis accelerometer MEMS sensor powered by the SPV1050 device. Moreover a microcontroller and an RF Sub-Giga transmitter all by ST are on board. The system has a receiver companion powered through a USB cable by the PC. For further details on the SPV1050 device please refer to the related datasheet. The reference design kit is supported by a software user-friendly GUI able to show PV module and battery electrical characteristics, conversion efficiency, MPPT accuracy and sensors readings.

The transmitter module is based on an STM32L151 low power microcontroller which controls sensors configuration and data communication. A digital temperature sensor (STTS751), a pressure sensor (LPS331AP) and a 3-axis accelerometer (LIS3DH) are connected to the microcontroller through the I²C bus.

1 Transmitter board schematics and bill of material

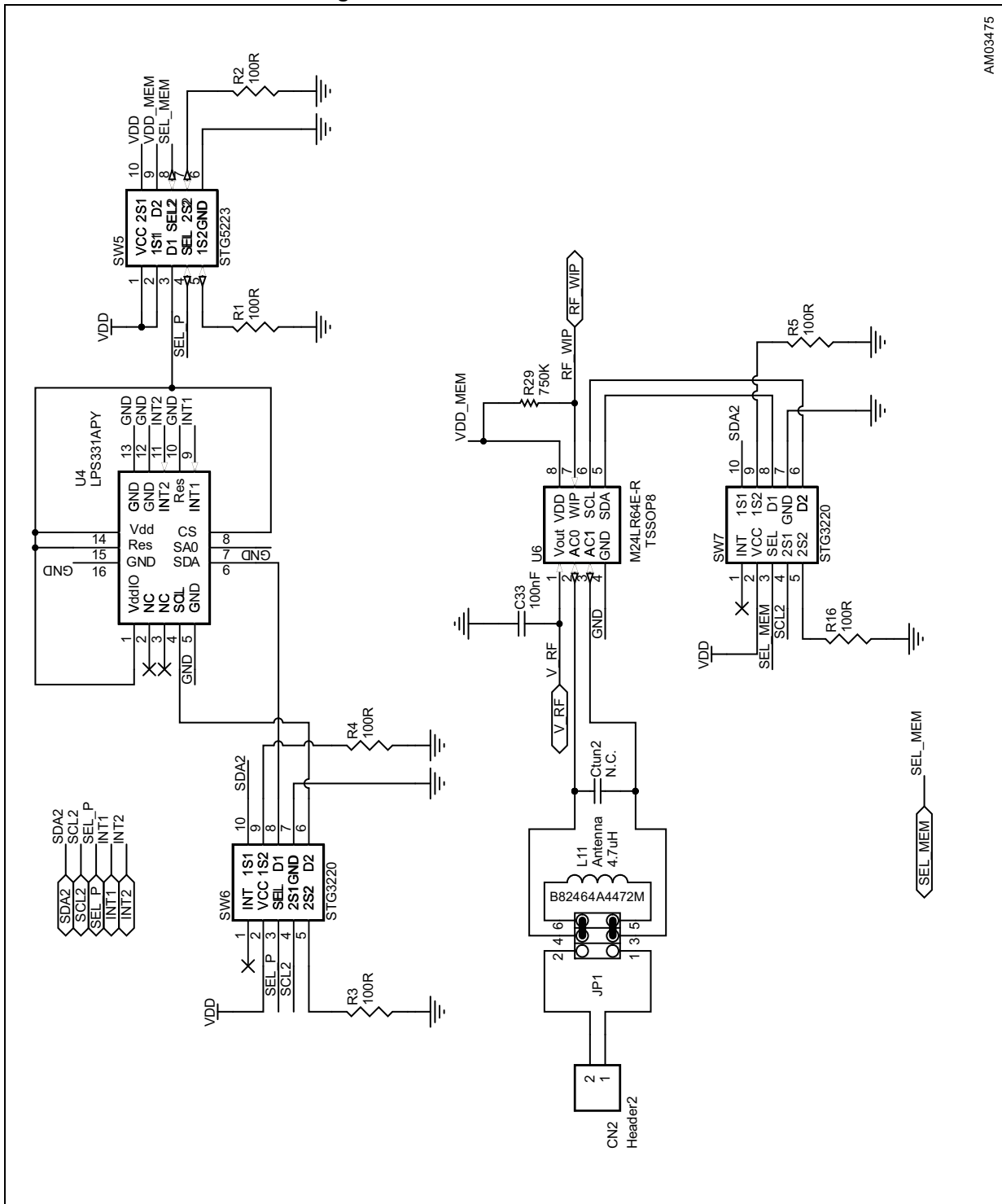
Figure 1. Board schematic - transmitter/receiver



AM03474

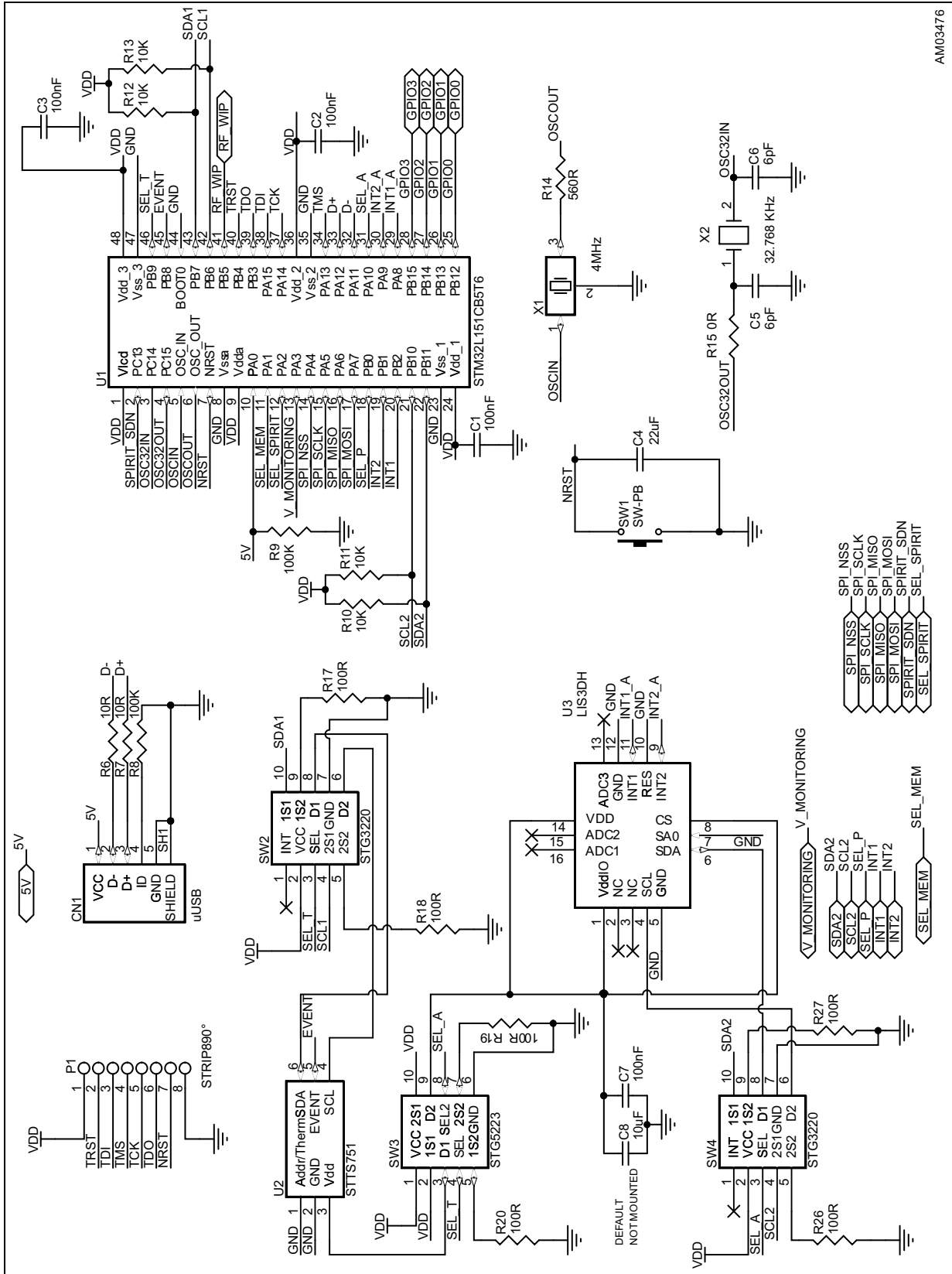


Figure 2. Board schematic - antenna



AM03475

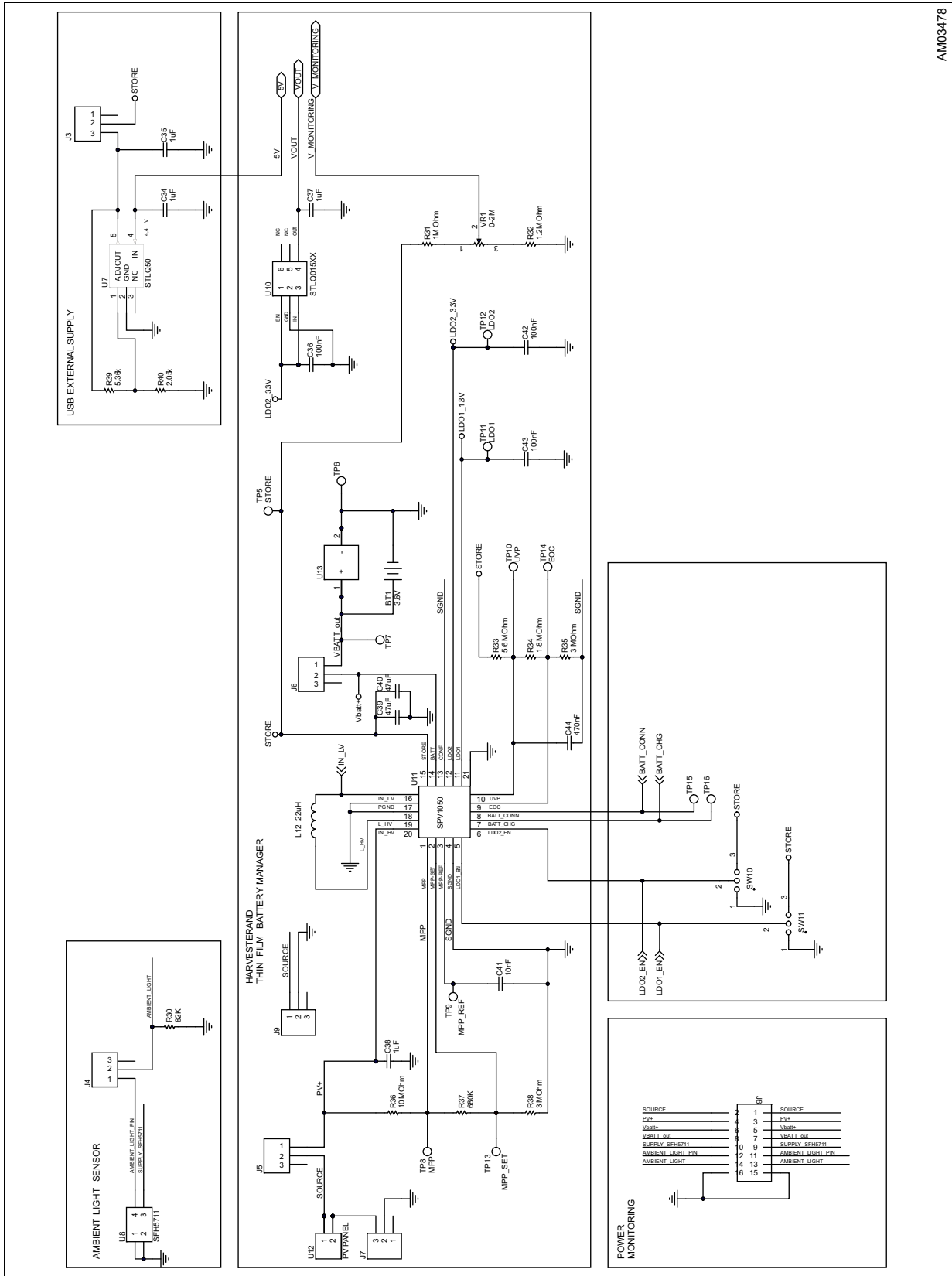
Figure 3. Board schematic - microcontroller



AM03476



Figure 4. Board schematic - photovoltaic harvester



AM03478



Table 1. Transmitter board - bill of material

Item	Qty.	Designator	SCI part number	Value
1	1	BT1	BATT-CR2450-3V6	3.6 V
2	9	C1, C2, C3, C7, C13, C15, C33, C42, C43	CCERSMD104-0402M	100 nF
3	1	C4	CCERSMD226-0603V	22 μ F
4	2	C5, C6	CCERSMD060-0402	6 pF
5	1	C8		10 μ F - DNM
6	2	C9, C20	CCERSMD106-0603R	10 μ F
7	1	C10	CCERSMD105-0603T	1 μ F
8	1	C11	CCERSMD101-0402M	100 pF
9	3	C12, C16, C28	CCERSMD331-0402	330 pF
10	1	C14	CCERSMD105-0603T	1 μ F
11	2	C17, Ctun1		DNM
12	2	C18, C23		DNM
13	1	C19	CCERSMD221-0603	220 pF
14	2	C21, C31	CCERSMD221-0402	220 pF
15	1	C22	CCERSMD070-0402	7 pF
16	1	C24	CCERSMD024-0402	2.4 pF
17	1	C25	CCERSMD036-0402	3.6 pF
18	2	C26, C27	CCERSMD180-0402	18 pF
19	1	C29	CCERSMD103-0402M	10 nF
20	1	C30	CCERSMD015-0402	1.5 pF
21	1	C32	CCERSMD020-0402	2 pF
22	2	C34, C35	CCERSMD105-0603T	1 μ F
23	1	C36	CCERSMD104-0603T	100 nF
24	2	C37, C38	CCERSMD105-0603T	1 μ F
25	2	C39, C40	CCERSMD476-0805K	47 μ F
26	1	C41	CCERSMD103-0603R	10 nF
27	1	C44	CCERSMD474-0603P	470 nF
28	1	CN1	USB-MICROB-SMD	μ USB
29	1	CN2	SAM-TSW10208GSRA	Header 2
30	1	Ctun2		DNM
31	4	D1, D2, D3, D4	DBAT41M-SMD	Schottky
32	1	J1	BNC-SMA-9EL-SMD	BNC
33	1	No reference: antenna to be screwed on J1	LPRS - WR868	868 MHz to 915 MHz, SMA antenna
34	1	J2	STRIP2PM	JUMPER

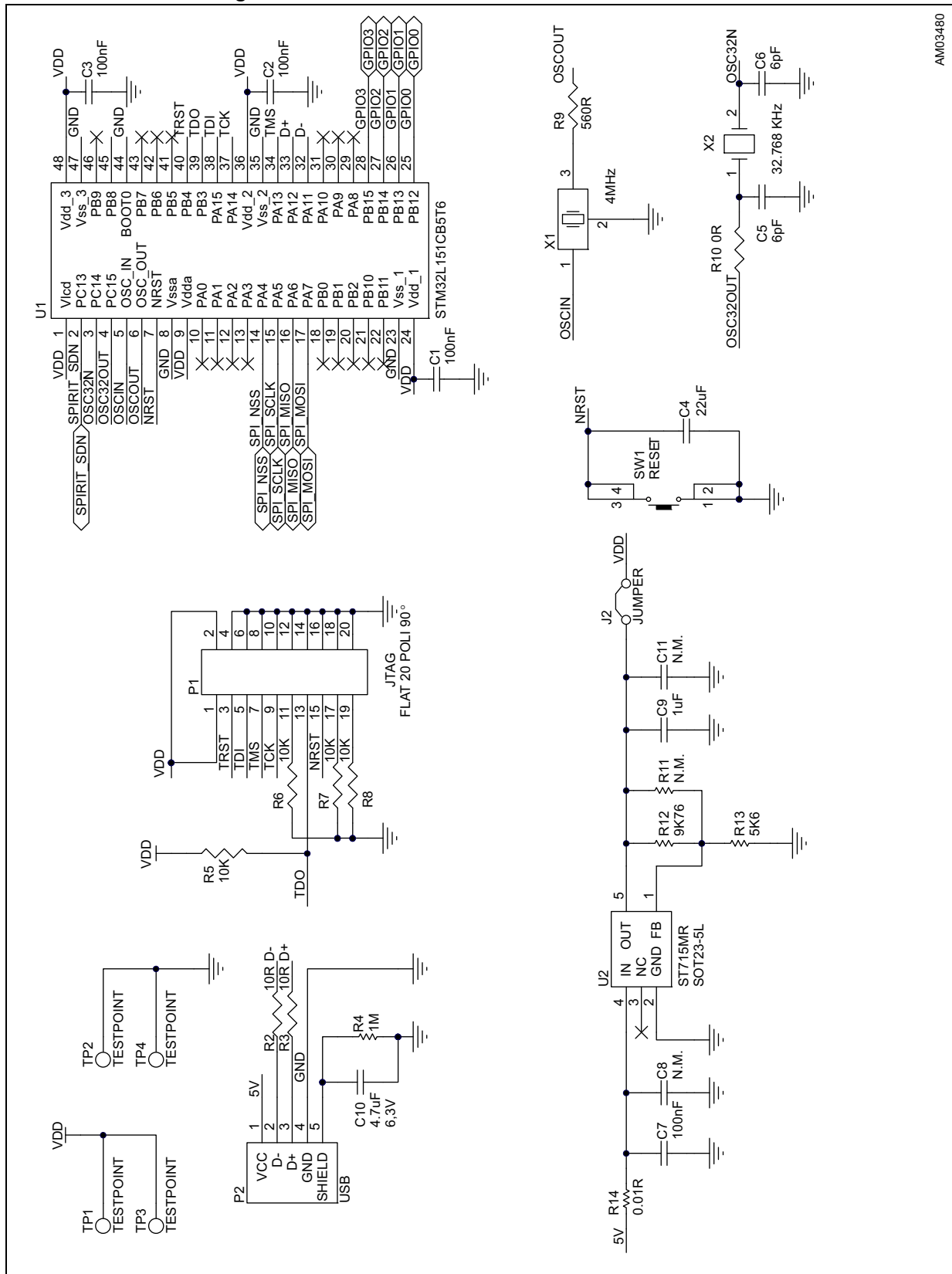
Table 1. Transmitter board - bill of material (continued)

Item	Qty.	Designator	SCI part number	Value
35	6	J3, J4, J5, J6, J7, J9	STRIP1X3-M-SMD	ST_19_STRIP3_100M_V_
36	1	J8	SAM-SMH10802GD	Header 8X2
37	1	JP1	SAM-TMM10302GD	STRIP2X3
38	1	L1	INDLQM21FN100M70	10 μ H
39	1	L2	IND0402CS-27N	27 nH
40	1	L3	INDLQG15HSR10J02	100 nH
41	1	L4		DNM
42	1	L5	INDLQG15HN3N6S02	3.6 nH
43	1	L6	INDLQG15HN5N1S02	5.1 nH
44	1	L7	RESMD000-0402	0 Ω
45	1	L8	INDLQG15HN18NJ02	18 nH
46	2	L9, L10	INDLQG15HN15NJ02	15 nH
47	1	L11	INDSMD4,7UH82464	Antenna
48	1	L12	IND-LPS4018223ML	22 μ H
49	1	P1	STRIP40PMD90	STRIP 8 POLI
50	13	R1, R2, R3, R4, R5, R16, R17, R18, R19, R20, R26, R27, R28	RESMD101-0402	100 Ω
51	2	R6, R7	RESMD100-0402	10 Ω
52	2	R8, R9	RESMD104-0402	100 K Ω
53	4	R10, R11, R12, R13	RESMD103-0402	10 K Ω
54	1	R14	RESMD561-0402	560 Ω
55	1	R15	RESMD000-0402	0 Ω
56	2	R21, R29	RESMD754-0603	750 K Ω
57	1	R22	RESMD244-0603	240 K Ω
58	1	R23	RESMD124-0603	120 K Ω
59	1	R24	RESMD104-0603	100 K Ω
60	1	R25	RESMD4223-0603	422 K Ω
61	1	R30	RESMD823-0603	82 K Ω
62	1	R31	RESMD105-0603	1 M Ω
63	1	R32	RESMD125-0603	1.2 M Ω
64	1	R33	RESMD562-0603	5.6 M Ω
65	1	R34	RESMD185-0603	1.8 M Ω
66	2	R35, R38	RESMD305-0603	3 M Ω
67	1	R36	RESMD106-0603	10 M Ω
68	1	R37	RESMD684-0603	680 K Ω

Table 1. Transmitter board - bill of material (continued)

Item	Qty.	Designator	SCI part number	Value
69	1	R39	RESMD5361-603-01	5.36 k Ω
70	1	R40	RESMD2051-0603	2.05 k Ω
71	1	SW1	PULS-B3U1100-SMD	SW-PB
72	4	SW2, SW4, SW6, SW7	STG3220QTR-SMD	STG3220
73	4	SW3, SW5, SW8, SW9	STG5223QTR-SMD	STG5223
74	2	SW10, SW11	RS 712-2558	SW SLIDE-SPST
75	3	TP1, TP3, TP17	TEST2	TEST2
76	2	TP2, TP4	TEST2-R	TEST2
77	12	TP5, TP6, TP7, TP8, TP9, TP10, TP11, TP12, TP13, TP14, TP15, TP16		DNM
78	1	U1	STM32L151-SMD	STM32L151CB5T6
79	1	U2	STTS7510WB3-SMD	STTS751
80	1	U3	LIS3DH-SMD	LIS3DH
81	1	U4	LPS331AP-SMD	LPS331APY
82	1	U5	SPIRIT1QTR-SMD	SPIRIT1
83	1	U6	M24LR64ER-SMD	M24LR64E-R
84	1	U7	STLQ50C-R-SMD	STLQ50
85	1	U8	PTR-SFH5711-SMD	SFH5711
86	1	U9	ST715MR-SMD	ST715MR
87	1	U10	STLQ015XG25R-SMD	STLQ015XX
88	1	U11	KIT-EXT	SPV1050
89	2	U12	PANN-AM-1801	PV PANEL
90	1	U13	BATT-HOLD-2450	BATT-HOLD-2450
91	1	VR1	RTR-3312-2M-SMD	0 - 2 M Ω
92	1	X1	Q4MHZ-SMD-RISZ	4 MHz
93	1	X2	Q32,768-ABS07SMD	XT-2PIN
94	1	XTAL1	Q50MHZ-TXC7M-SMD	50 MHz

Figure 10. Receiver board schematic - microcontroller



AM03480

Table 2. Receiver board - bill of material

Qty.	Designator	Part number SCI	Comment	Part description
5	C1, C2, C3, C15, C17	CCERSMD104-0402M	100 nF	Mult. cer. cap. 16 V SMD 0402
1	C4	CCERSMD226-0603V	22 μ F	Mult. cer. cap. 6.3 V SMD 0603
2	C5, C6	CCERSMD060-0402	6 pF	Mult. cer. cap. 50 V SMD 0402
1	C7	CCERSMD104-0603V	100 nF	Mult. cer. cap. 50 V SMD 0603
2	C8, C11		N. M.	Mult. cer. cap. 6.3 V SMD 0603
1	C9	CCERSMD105-0603M	1 μ F	Mult. cer. cap. 25 V SMD 0603
1	C10	CCERSMD475-0603	4.7 μ F	Mult. cer. cap. 6.3 V SMD 0603
1	C13	CCERSMD101-0402M	100 pF	Mult. cer. cap. 50 V SMD 0402
3	C14, C18, C26	CCERSMD331-0402	330 pF	Mult. cer. cap. 50 V SMD 0402
2	C19, Ctun1		N. C.	Mult. cer. cap. SMD 0402
2	C20, C29	CCERSMD221-0402	220 pF	Mult. cer. cap. 50 V SMD 0402
1	C21	CCERSMD070-0402	7 pF	Mult. cer. cap. 50 V SMD 0402
1	C22	CCERSMD024-0402	2.4 pF	Mult. cer. cap. 50 V SMD 0402
1	C23	CCERSMD036-0402	3.6 pF	Mult. cer. cap. 50 V SMD 0402
2	C24, C25	CCERSMD180-0402	18 pF	Mult. cer. cap. 50 V SMD 0402
1	C27	CCERSMD103-0402M	10 nF	Mult. cer. cap. 50 V SMD 0402
1	C28	CCERSMD015-0402	1.5 pF	Mult. cer. cap. 50 V SMD 0402
1	C30	CCERSMD020-0402	2pF	Mult. cer. cap. 50 V SMD 0402
1	J1	BNC-SMA-9EL-SMD	BNC	Female SMA end launch jack
1	No reference: antenna to be screwed on J1	LPRS - WR868	Antenna	868 MHz to 915 MHz, SMA antenna
1	J2	STRIP2PM	Jumper	Male strip 2 poles
1	L1	INDLQM21FN100M70	10 μ H	SMPS out inductor - Murata LQM21 series
1	L2	IND0402CS-27N	27 nH	SMPS out inductor - Coilcraft
1	L3	INDLQG15HSR10J02	100 nH	TX PA choke
1	L4		N. C.	SMD inductor 0402
1	L5	INDLQG15HN3N6S02	3.6 nH	TX LPF 1 st series
1	L6	INDLQG15HN5N1S02	5.1 nH	TX LPF 2 nd series
1	L7	RESMD000-0402	0 Ω	Resistor 1/16 W 1% SMD 0402
1	L8	INDLQG15HN18NJ02	18 nH	TX LPF 2 nd series
2	L9, L10	INDLQG15HN15NJ02	15 nH	TX LPF 2 nd series
1	P1	M.20.90 LP	20 Flat	20-way flat connector (horizontal)
1	P2	SAMTECUSBB	USB	SAMTEC USB B connector, right angle
2	R2, R3	RESMD100-0402	10 Ω	Resistor 1/16 W 1% SMD 0402
1	R4	RESMD105-0402	1 M Ω	Resistor 1/16 W 1% SMD 0402

Table 2. Receiver board - bill of material (continued)

Qty.	Designator	Part number SCI	Comment	Part description
4	R5, R6, R7, R8	RESMD103-0402	10 K Ω	Resistor 1/16 W 1% SMD 0402
1	R9	RESMD561-0402	560 Ω	Resistor 1/16 W 1% SMD 0402
1	R10	RESMD000-0402	0 Ω	Resistor 1/16 W 1% SMD 0402
1	R11		N. M.	Resistor 1/10 W 1% SMD 0603
1	R12	RESMD9761-0603	9.76 K Ω	Resistor 1/10 W 1% SMD 0603
1	R13	RESMD562-0603	5.6 K Ω	Resistor 1/10 W 1% SMD 0603
1	R14	RESMD0R01-0603	0.01 Ω	Resistor 1/10 W 1% SMD 0603
1	SW1	PULS-DTSM61-SMD	Reset	Pushbutton_SMD
2	TP1, TP3	TEST2-R	TEST2	PCB test point - raised loops
2	TP2, TP4	TEST2	TEST2	PCB test point - raised loops
1	U1	STM32L151-SMD	STM32L15 1CB5T6	Microprocessor - SMD LQFP48
1	U2	ST715MR-SMD	ST715MR	High input voltage - 85 mA LDO linear regulator - SOT23-5L
1	U3	KIT-EXT	SPIRIT1	ST
1	X1	Q4MHZ-SMD-RISZ	4 MHz	4 MHz SMD RESONATOR
1	X2	Q32,768-ABS07SMD	XT-2PIN	QUARTZ ABRACON SMD ABS07
1	XTAL1	Q50MHZ-TXC7M-SMD	50 MHz	QUARTZ 50 MHz SMD TXC 7M series

4 Receiver board layout

Figure 11. Receiver board - top layer view

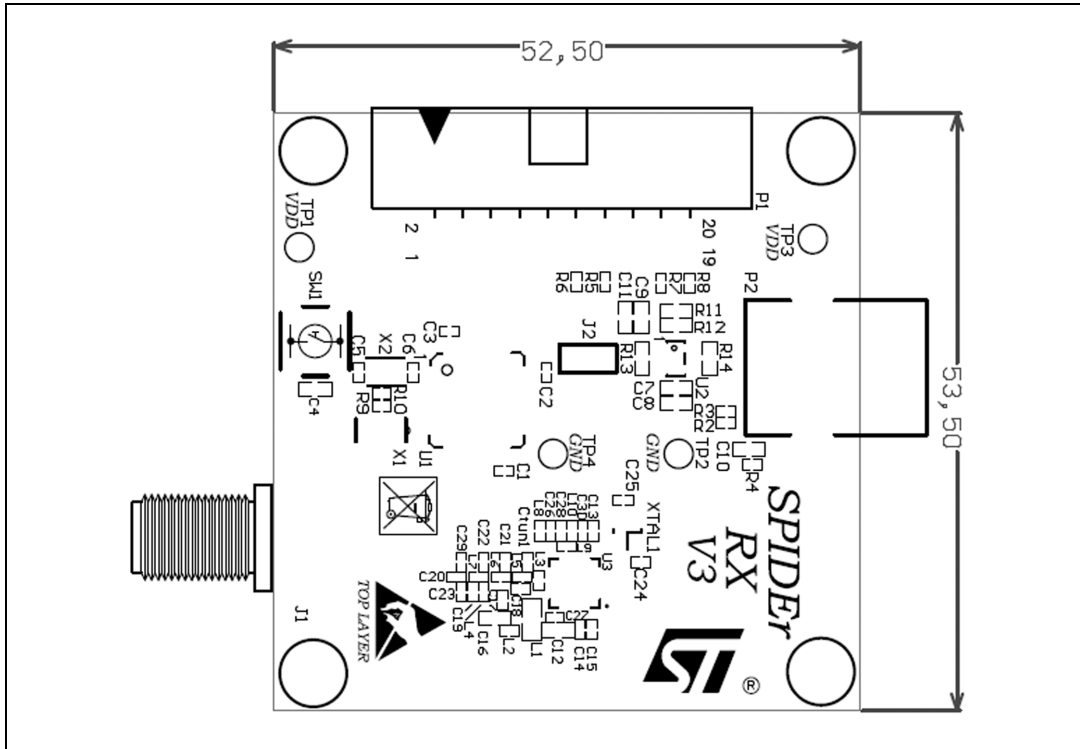
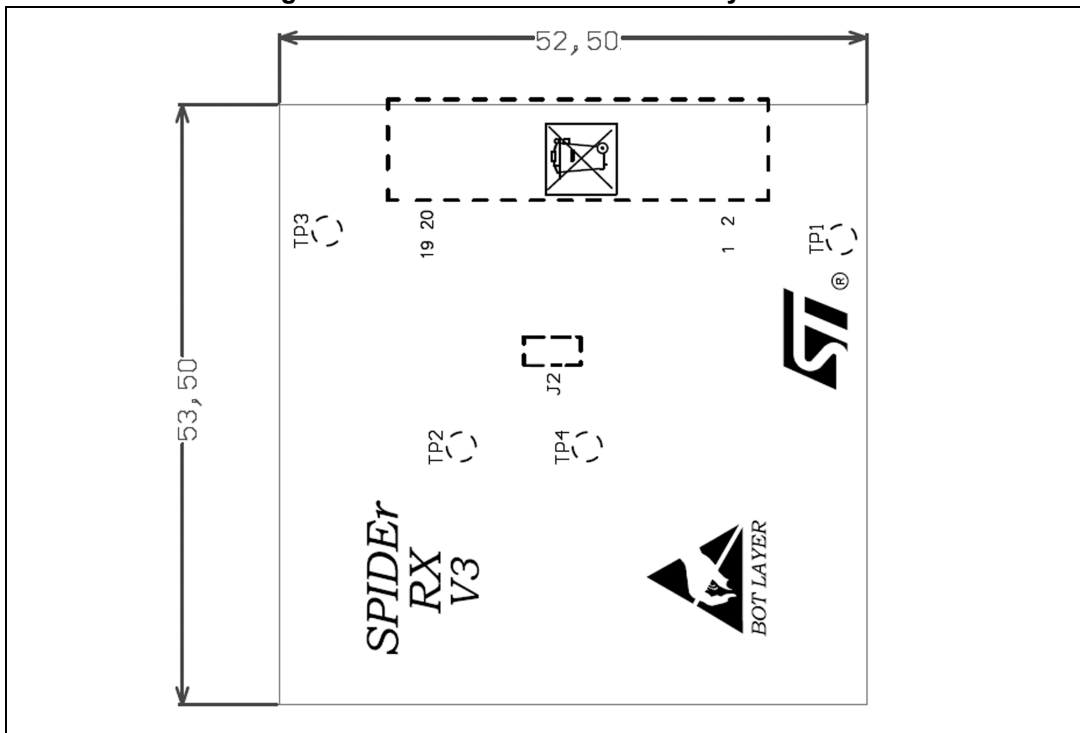


Figure 12. Receiver board - bottom layer view



5 Revision history

Table 3. Document revision history

Date	Revision	Changes
28-Nov-2013	1	Initial release.

Please Read Carefully:

Information in this document is provided solely in connection with ST products. STMicroelectronics NV and its subsidiaries ("ST") reserve the right to make changes, corrections, modifications or improvements, to this document, and the products and services described herein at any time, without notice.

All ST products are sold pursuant to ST's terms and conditions of sale.

Purchasers are solely responsible for the choice, selection and use of the ST products and services described herein, and ST assumes no liability whatsoever relating to the choice, selection or use of the ST products and services described herein.

No license, express or implied, by estoppel or otherwise, to any intellectual property rights is granted under this document. If any part of this document refers to any third party products or services it shall not be deemed a license grant by ST for the use of such third party products or services, or any intellectual property contained therein or considered as a warranty covering the use in any manner whatsoever of such third party products or services or any intellectual property contained therein.

UNLESS OTHERWISE SET FORTH IN ST'S TERMS AND CONDITIONS OF SALE ST DISCLAIMS ANY EXPRESS OR IMPLIED WARRANTY WITH RESPECT TO THE USE AND/OR SALE OF ST PRODUCTS INCLUDING WITHOUT LIMITATION IMPLIED WARRANTIES OF MERCHANTABILITY, FITNESS FOR A PARTICULAR PURPOSE (AND THEIR EQUIVALENTS UNDER THE LAWS OF ANY JURISDICTION), OR INFRINGEMENT OF ANY PATENT, COPYRIGHT OR OTHER INTELLECTUAL PROPERTY RIGHT.

ST PRODUCTS ARE NOT DESIGNED OR AUTHORIZED FOR USE IN: (A) SAFETY CRITICAL APPLICATIONS SUCH AS LIFE SUPPORTING, ACTIVE IMPLANTED DEVICES OR SYSTEMS WITH PRODUCT FUNCTIONAL SAFETY REQUIREMENTS; (B) AERONAUTIC APPLICATIONS; (C) AUTOMOTIVE APPLICATIONS OR ENVIRONMENTS, AND/OR (D) AEROSPACE APPLICATIONS OR ENVIRONMENTS. WHERE ST PRODUCTS ARE NOT DESIGNED FOR SUCH USE, THE PURCHASER SHALL USE PRODUCTS AT PURCHASER'S SOLE RISK, EVEN IF ST HAS BEEN INFORMED IN WRITING OF SUCH USAGE, UNLESS A PRODUCT IS EXPRESSLY DESIGNATED BY ST AS BEING INTENDED FOR "AUTOMOTIVE, AUTOMOTIVE SAFETY OR MEDICAL" INDUSTRY DOMAINS ACCORDING TO ST PRODUCT DESIGN SPECIFICATIONS. PRODUCTS FORMALLY ESCC, QML OR JAN QUALIFIED ARE DEEMED SUITABLE FOR USE IN AEROSPACE BY THE CORRESPONDING GOVERNMENTAL AGENCY.

Resale of ST products with provisions different from the statements and/or technical features set forth in this document shall immediately void any warranty granted by ST for the ST product or service described herein and shall not create or extend in any manner whatsoever, any liability of ST.

ST and the ST logo are trademarks or registered trademarks of ST in various countries.

Information in this document supersedes and replaces all information previously supplied.

The ST logo is a registered trademark of STMicroelectronics. All other names are the property of their respective owners.

© 2013 STMicroelectronics - All rights reserved

STMicroelectronics group of companies

Australia - Belgium - Brazil - Canada - China - Czech Republic - Finland - France - Germany - Hong Kong - India - Israel - Italy - Japan - Malaysia - Malta - Morocco - Philippines - Singapore - Spain - Sweden - Switzerland - United Kingdom - United States of America

www.st.com

