STEVAL-IHT005V2 - 3.3 V control of ACS[®]/Triac with STM32[™]

Introduction

The STEVAL-IHT005V2 demonstration board is designed for the home appliance market, with a focus on the demonstration of a robust solution with a 3.3 V supplied 32-bit MCU. Targeted applications are mid-end and high-end washing machines, dishwashers and dryers with different kinds of ACS[®]/Triacs.

The demonstration board is based on the recently introduced 48-pin, 32-bit STM32F100C4T6B MCU running at 24 MHz (RC user-trimmable internal RC clock), featuring 16 kBytes of Flash memory, 12-bit A/D converter, 5 timers, communication interfaces, and 4 kBytes of SRAM.

The power supply circuitry is based on the VIPer[®]16L, an offline converter with an 800 V avalanche rugged power section, operating at 60 kHz. The power supply provides negative 6 V in buck-boost topology.

The STEVAL-IHT005V2 can control 2 high power loads up to 2830 W thanks to the T1635H, a 16 A, 600 V high temperature Triac and up to 2050 W thanks to the ACST1635-8FP a 16 A, 800 V high temperature overvoltage protected ACST device. The high power load control is based on phase angle control. In order to limit the inrush current and possible current peaks, the demonstration board features a soft-start routine and a smooth power change function for the high power loads.

The STEVAL-IHT005V2 can also control 4 low power loads up to 100 W thanks to 3 ACS108-8S, 0.8 A, 800 V overvoltage protected ACS devices and a Z0109, 1 A standard 4 quadrant 600 V Triac.

The demonstration board passed the precompliance tests for EMC directives IEC 61000-4-4 (burst up to 8 kV) and IEC 61000-4-5 (surge up to 2 kV).

When put in standby mode, the STEVAL-IHT005V2 has an overall standby power consumption below 500 mW at 264 V/50 Hz.

Figure 1. STEVAL-IHT005V2

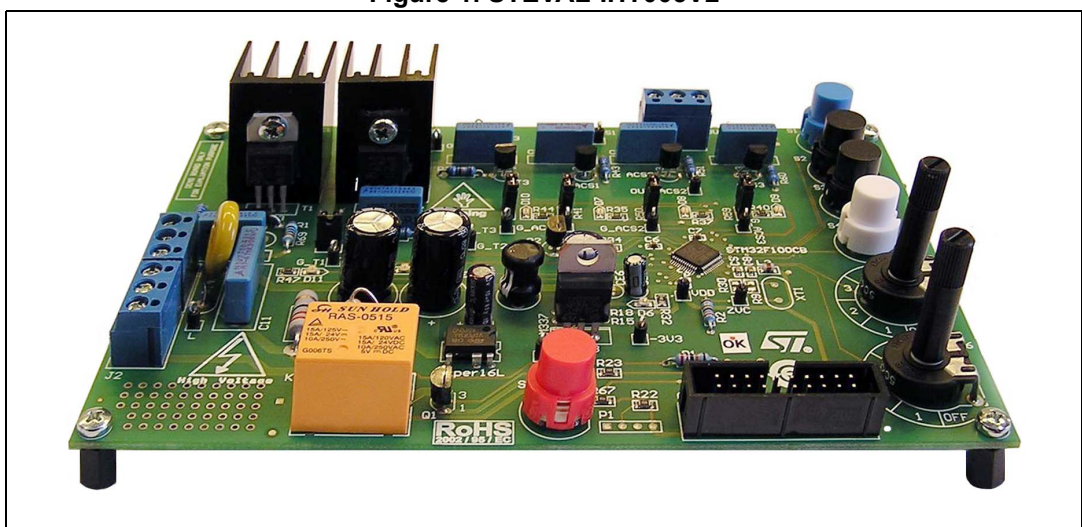

Contents

- 1 Board features and objectives 4**
 - 1.1 Objectives 4
 - 1.2 Board features 5
 - 1.3 Targeted applications 5
 - 1.4 Operating conditions 5

- 2 Safety instructions 6**
 - 2.1 Intended use 6
 - 2.2 Installation 6
 - 2.3 Electrical connection 6
 - 2.4 Board operation 6

- 3 Getting started 7**
 - 3.1 Connection diagram 7
 - 3.2 How to operate the STEVAL-IHT005V2 7
 - 3.3 MCU programming 9
 - 3.4 Load and gate control fitting 9

- 4 Functional description 10**
 - 4.1 Phase angle control 10
 - 4.2 Full wave control 10

- 5 Power supply consumption 12**
 - 5.1 Max. output current and standby consumption 12
 - 5.2 Gate voltage impact on gate current 12
 - 5.3 Pulsed gate control and average gate current consumption 13

- 6 Board immunity performances 14**
 - 6.1 Hardware and software features to increase immunity 14
 - Software features 14
 - 6.2 Surge tests results 14

6.3	Burst tests results	15
6.3.1	Test procedure	15
6.3.2	Test results of the board without hardware modifications	15
6.3.3	Input filter influence	15
6.3.4	Noise suppressor influence	16
6.3.5	Gate filtering circuit influence	17
6.3.6	Immunity to relay switching	17
Appendix A	STEVAL-IHT005V2 schematic	19
A.1	Schematic	19
A.2	Demonstration board layout	20
A.3	Test point lists	21
A.4	Gate resistor calculation	21
	Gate resistor calculation.	21
	Assumptions for calculation	22
A.5	Bill of material	23
Revision history		26

1 Board features and objectives

1.1 Objectives

The board is designed for promotion of a complete solution for home appliance applications based on STMicroelectronics™ components. Special emphasis is placed on demonstration of the robust full 3.3 V solution. Robustness is demonstrated on 4 kV level in class A during IEC-61000-4-4 (burst) test.

This board also allows designers to check AC switches control feasibility with a 3.3 V supply. Gate currents can be measured and compared to the information given in AN2986.

Promoted parts are

- STM32F100C4T6B - value line 32-bit MCU
- T1635H-6T - 16 A 600 V 35 mA high temperature Snubberless™ Triac in TO-220 package
- ACST1635-8FP - 16 A 800 V high temperature overvoltage protected AC switch in TO-220 FPAB package
- ACS108-8SA - 0.8 A 800 V 10 mA overvoltage protected ACS device in TO-92 package
- Z0109MA - 1 A standard 10 mA 4Q Triac in TO-92 package
- VIPer16L - an offline converter with 800 V avalanche rugged power section operating at 60 kHz.

The ACS108 and Z0109 are controlled in ON/OFF mode with the buttons. These devices control small loads like valves, pumps, and door locks.

The T1635H and ACST16 are controlled in phase control mode with potentiometers. These devices control high power loads like drum motors or heating resistors.

1.2 Board features

The board key features and performances are

- Complete solution for -3.3 V control
- Input voltage range: 90-265 VAC 50/60 Hz
- Negative 6 V/3.3 V VDC auxiliary power supply based on the VIPer16L in buck-boost topology
- Total power consumption in standby mode is lower than 0.5 W for 264 V/50 Hz
- 48-pin, 32-bit value line family STM32F100C4T6B MCU as main controller
- Zero voltage switching (ZVS) interrupt to synchronize MCU events with voltage mains
- 1x T1635H-6T and 1 x ACST1635-8FP for phase control of high power loads
- 5 discrete power level states with soft change for phase angle controlled devices
- 1x Z0109 and 3x ACS108 for full wave control of low power loads
- 1x relay for demonstration of the board noise robustness
- “Red” LED to show that the board is supplied from mains
- “Green” LED for each ACS/ACST/Triac to show that the device is turned ON
- JTAG programming connector
- External wire loop for gate current measurement
- I²C bus hardware/software ready
- 18 test pins
- IEC 61000-4-4 precompliance test passed (burst up to 8 kV)
- IEC 61000-4-5 precompliance test passed (surge up to 2 kV)
- RoHS compliant

1.3 Targeted applications

Targeted applications are mid-end and high-end washing machines, dishwashers, dryers, and coffee machines.

Optionally, this board targets any home-appliance application where the STM32 MCU controls any type of Triac/ACST/ACS.

1.4 Operating conditions

The board operates in nominal line voltage 110 V/230 V in both 50/60 Hz power nets.

- Line voltage: 90-264 V 50/60 Hz
- Operating ambient temperature 0 °C to 60 °C
- Nominal loads power (for 230 V voltage)
 - ACST1635-8FP - 2050 W
 - T1635H-6T - 2830 W
 - Z0109MA - 96 W
 - ACS108-8SA - 105 W

2 Safety instructions

Warning: The high voltage levels used to operate the STEVAL-IHT005V2 board could present a serious electrical shock hazard. This demonstration board must be used in a suitable laboratory by qualified personnel only, familiar with the installation, use, and maintenance of power electrical systems.

2.1 Intended use

The STEVAL-IHT005V2 demonstration board is a component designed for demonstration purposes only, and not to be used either for domestic installation or for industrial installation. The technical data as well as the information concerning the power supply and working conditions should be taken from the documentation included in the kit and strictly observed.

2.2 Installation

Installation instructions for the STEVAL-IHT005V2 demonstration board must be taken from the present user manual and strictly observed. The components must be protected against excessive strain. In particular, no components are to be bent, or isolating distances altered during transportation, handling or use. No contact must be made with electronic components and contacts. The STEVAL-IHT005V2 demonstration board contains electrostatically sensitive components that are prone to damage through improper use. Electrical components must not be mechanically damaged or destroyed (to avoid potential risks and health injury).

2.3 Electrical connection

Applicable national accident prevention rules must be followed when working on the mains power supply. The electrical installation must be completed in accordance with the appropriate requirements (e.g. cross-sectional areas of conductors, fusing, PE connections). In particular, the programming device must be disconnected from the board JTAG connector when the board is plugged into the mains.

2.4 Board operation

A system architecture which supplies power to the demonstration board must be equipped with additional control and protective devices in accordance with the applicable safety requirements (e.g. compliance with technical equipment and accident prevention rules).

Note: Do not touch the board after disconnection from the mains power supply, as several parts and power terminals which contain possibly energized capacitors need to be allowed to discharge completely.

3 Getting started

3.1 Connection diagram

Figure 2 shows an image of the board with proper connection of each application.

Figure 2. Board connector

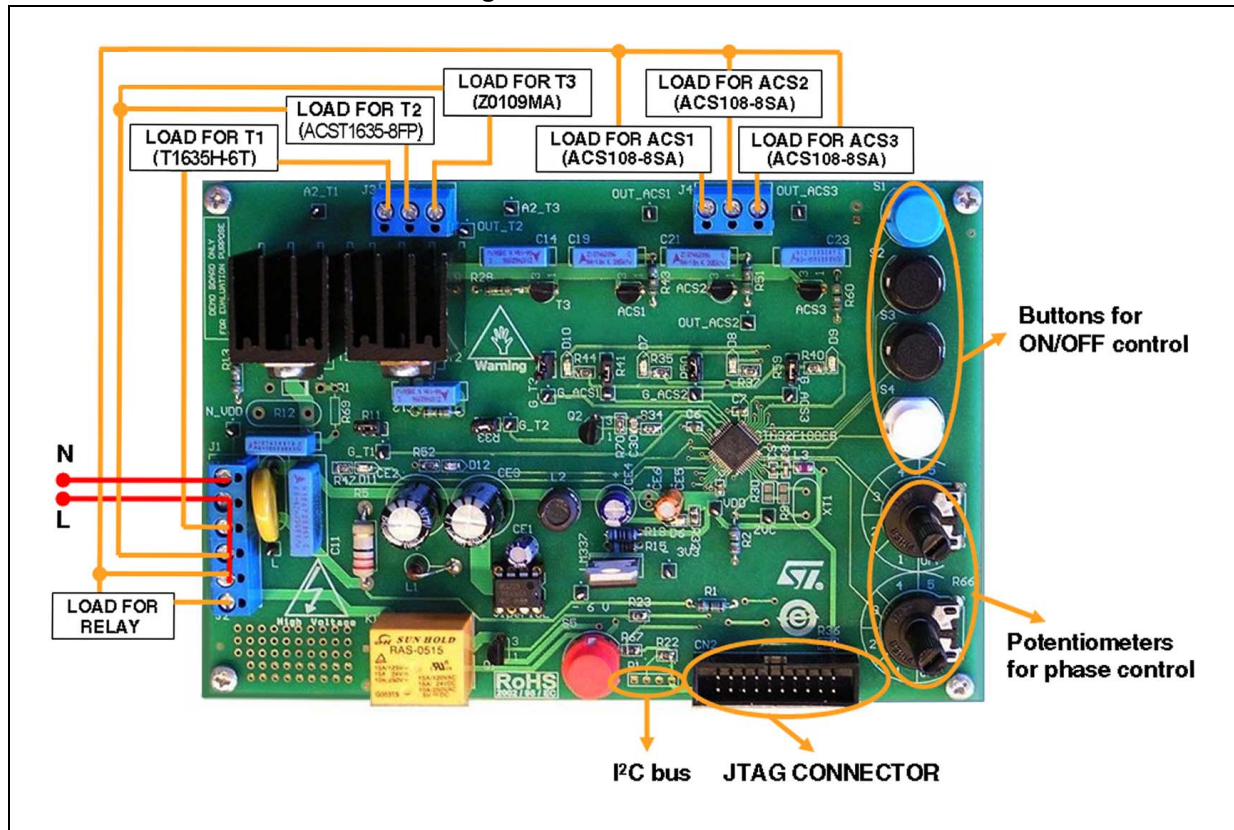

Note: Connect loads and voltage probes before applying line voltage.

3.2 How to operate the STEVAL-IHT005V2

Line voltage must be connected in position as described in Figure 2. The demonstration board can be operated with or without the load. Even if no load is connected to the demonstration board, all signals are present and can be displayed on the oscilloscope. Red LED D6 signals the board is properly supplied from the mains. It also signals that high voltage is present on the demonstration board.

It is recommended, although not required, to turn both potentiometers to the OFF position before powering the demonstration board. The board is ready to operate after passing all initialization routines, like mains frequency recognition, that take approximately 2 s.

Potentiometer R65 controls T1 (T1635H) and potentiometer R66 controls T2 (ACST16). Output power level is adjusted by changing the position of the related potentiometer. Power regulation is divided into 5 steps where position 1 means minimum power and position 5 means maximum power. LED D11 for T1 (T1635H) and LED D12 for T2 (ACST16) signal

that the gate control signal is applied. If the load (example motor) is running and the LED lights up, it indicates the MCU properly controls the Triac(s).

Blue, black and white buttons control the 3x ACS108 and Z01 in ON/OFF mode with zero voltage synchronization. The blue button S1 controls ACS1, black button S2 controls ACS2, black button S3 controls ACS3 and white button S4 controls T3. The different colors are used for easy recognition of the controlled device.

ACS2 and ACS3 are controlled with 2 ms gate pulses. This is sufficient for loads with RMS current approximately in the range of 100 mA - 500 mA. Smaller loads should be controlled with ACS1, which has continuous gate control.

T3 is controlled with 2 ms pulses and is used for comparison with ACS2 and ACS3 behavior. LED D10 for T3 (Z01), LED (D7) for ACS1 (ACS108-8S), LED D8 for ACS2 (ACS108-8S) and LED D9 for ACS3 (ACS108-8S) signals that the gate control signal is applied.

The red button S5 controls relay R1. Relay is controlled in the continuous DC mode. The DC control starts in zero voltage for control coil.

Note: The coil control in zero voltage does not lead to accurate “Zero Voltage Switching” of the power contacts.

Button control is used in a two-step control. When the button is first pushed it turns the related device ON. A second push of the button turns the related device OFF. All devices controlled by buttons are set in the OFF position after reset.

Figure 3. Overview of the demonstration board operation

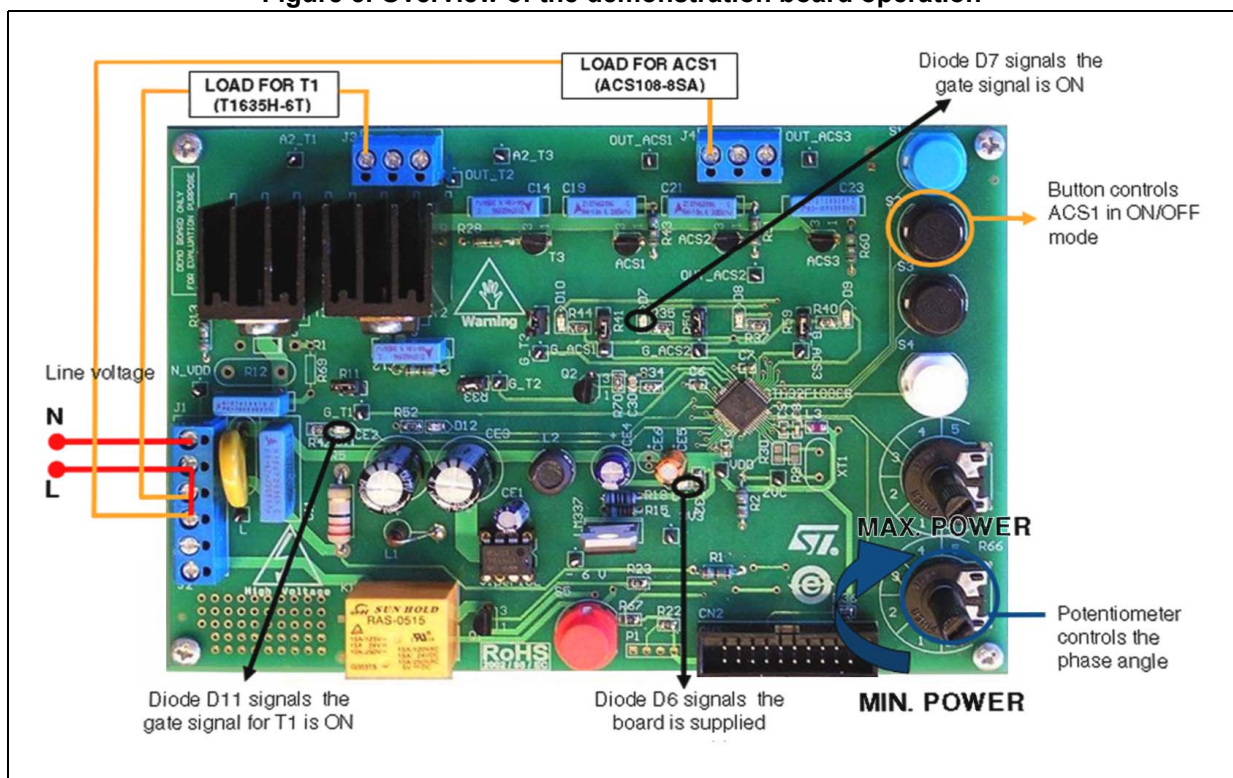

3.3 MCU programming

Once the demonstration board has the mains cable and load cable correctly connected, it can be powered on. The STEVAL-IHT005V2 demonstration board goes to wait-for-signal mode immediately after powering it on.

A JTAG connector for MCU programming is used when software modifications are necessary.

Warning: Programming device has to be galvanically isolated from mains when programmed directly on mains.

3.4 Load and gate control fitting

Gate current pulse is generated by the MCU. The length of the pulse is set by software. Gate current pulse length is important. Its value must be set according to the minimum load current. The load current has to reach the AC switch latching current value to keep the device ON after the gate pulse is removed. Latching current (I_L) is specified in the AC switch datasheet - ACS108-8S. It is important to check this point for low power loads when RMS current is low and it takes a long time to reach the latching current level. When gate current is removed before the load current reaches latching current, the device may turn off. Refer to the AN302 application note for further information on latching current.

The maximum value and length of the gate current the board can provide depends on power supply rating. The power supply used in the demonstration board is able to provide 120 mA continuously in full range of the operating voltage.

4 Functional description

Two different types of ACS/Triac control are implemented. Phase angle control and full wave control. The gate control signal is synchronized with zero voltage crossing signal (ZVC). The MCU operation is also synchronized with ZVC signal. ZVC signal is sent directly to the MCU input pin that is set as external interrupt.

4.1 Phase angle control

Control of T1 (T1635H) and T2 (ACST16) is based on phase angle control.

Figure 4. Phase angle control description

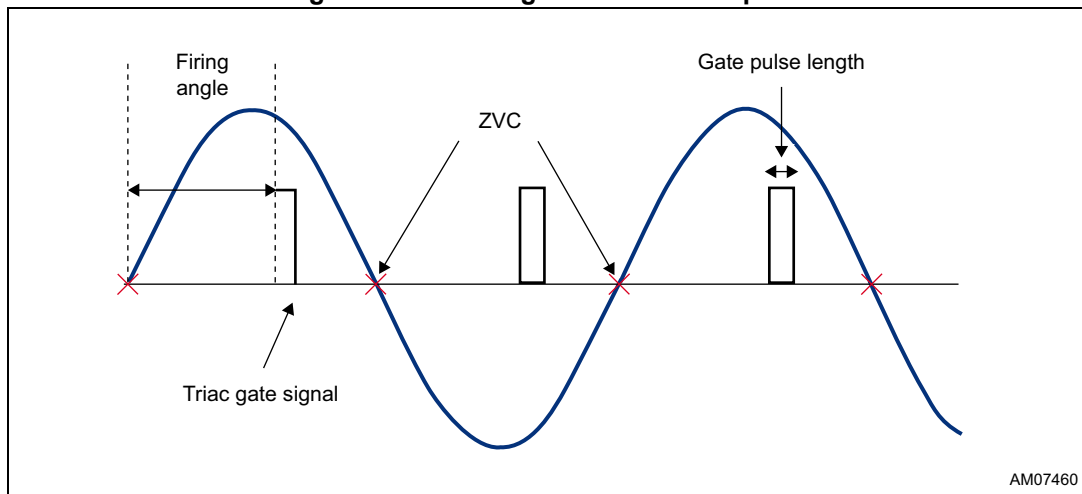

Phase angle control is based on changing the firing angle (delay). The firing angle determines the power that is delivered to the load. The shorter the firing angle (delay), the higher the power.

Firing angle and gate control pulse are defined by software. [Table 1](#) shows initial setting of firing angle.

Table 1. Firing angle delay

	Level 1	Level 2	Level 3	Level 4	Level 5
Firing angle (delay)	8.5 ms	6.9 ms	5.2 ms	3.6 ms	2.0 ms

4.2 Full wave control

Control of T3 (Z0109), ACS1, ACS2, and ACS3 (all ACS108-8S) is based on full wave pulse control.

Figure 5. Full wave control description

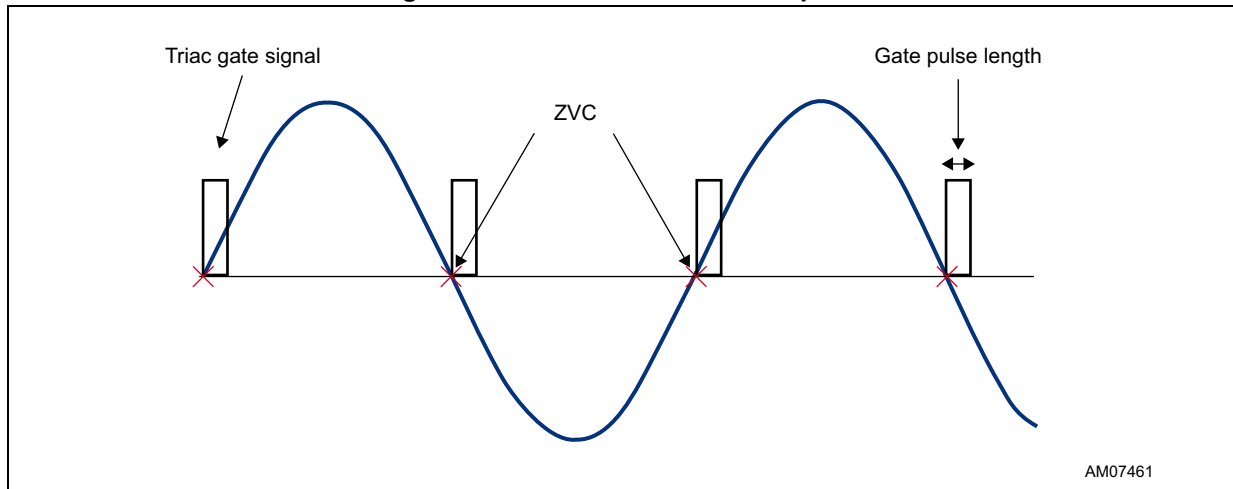

Full wave pulse control is based on sending gate control pulse immediately after ZVC signal. Gate control pulse length is defined by the software.

Refer to [Table 2](#) for default gate current pulse duration for all AC switches. Duration of each pulse is set separately for 50 Hz and 60 Hz mains.

Table 2. Initial gate current pulse duration

Device	Variable name for 50 Hz mains	Initial gate pulse duration (ms/timer steps) ⁽¹⁾	Variable name for 60 Hz mains	Initial gate pulse duration (ms/timer steps) ⁽¹⁾
ACS1	ACS_1_SWITCHTIME_50HZ	10/100	ACS_1_SWITCHTIME_60HZ	8.3/83
ACS2	ACS_2_SWITCHTIME_50HZ	2/20	ACS_2_SWITCHTIME_60HZ	1.6/16
ACS3	ACS_3_SWITCHTIME_50HZ	2/20	ACS_3_SWITCHTIME_60HZ	1.6/16
Z0109	Z0109_SWITCHTIME_50HZ	2/20	Z0109_SWITCHTIME_60HZ	1.6/16
ACST16	ACST16_SWITCHTIME_50HZ	1/10	ACST16_SWITCHTIME_60HZ	0.8/8
T1635H	T1635H_SWITCHTIME_50HZ	1/10	T1635H_SWITCHTIME_60HZ	0.8/8

1. The timer step is 100 μs.

5 Power supply consumption

5.1 Max. output current and standby consumption

Non-isolated SMPS based on the VIPer16 in buck-boost topology is designed to provide output voltage of -6 V. Maximum output current is 120 mA. -3.3 V voltage supply necessary to supply MCU consists of linear regulator LM337.

Standby consumption has been measured in full range of the supply voltage. The standby power consumption fulfills the requirement of maximum total power consumption to be below 500 mW.

Total power consumption of the board in standby mode at supply voltage of 264 Vrms/50 Hz was 499 mW (output current 10 mA at output voltage -6 V).

The power supply uses mains voltage for self supply from high voltage current generator. Standby power consumption can be reduced by using the configuration with VIPer16 supply made from the low voltage side. Refer to the AN2872 application note and VIPer16 datasheet for further information on power supply design.

5.2 Gate voltage impact on gate current

Gate voltage V_{GT} varies with load current as shown in *Figure 4 Figure 6?*. This variation is significant and cannot be neglected mainly for devices that are controlled in DC mode and with low power supply level such as 3.3 V.

Figure 6. Example of V_{GT} variation with load current in quadrants 2 and 3 (0.2 A RMS) for a Z0103 ($T_j = 85\text{ }^\circ\text{C}$, $I_{G0} = 7.5\text{ mA}$)

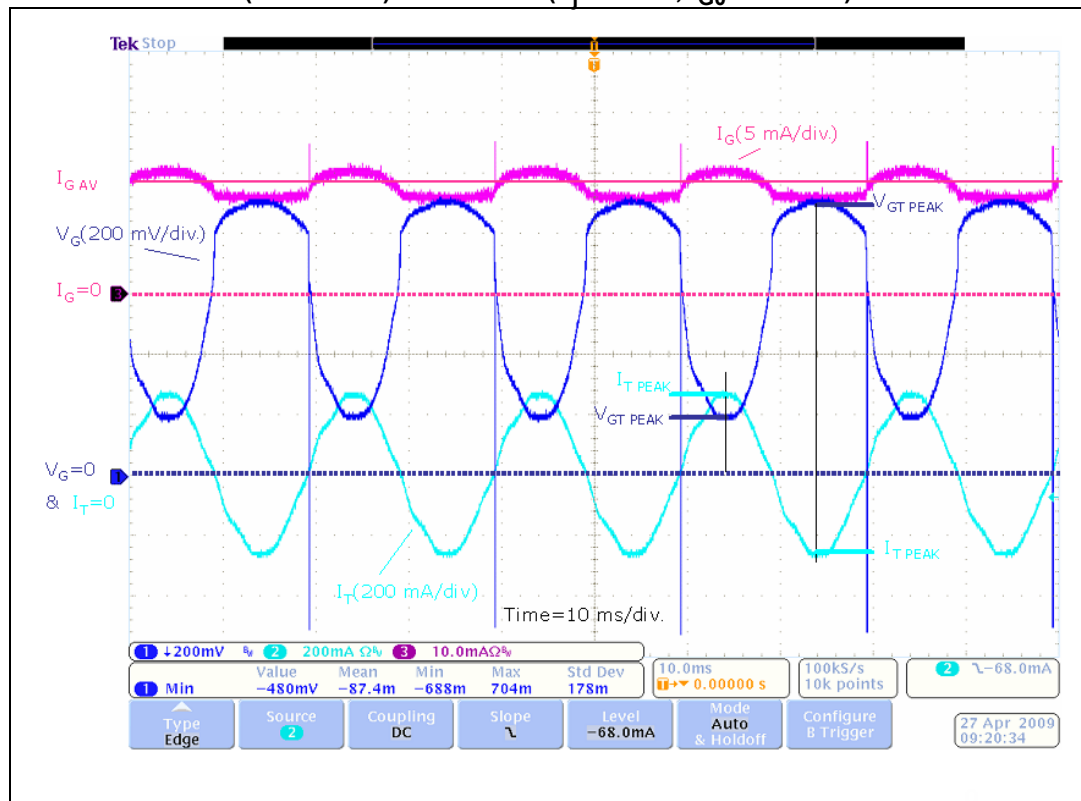

ACS devices have lower V_{GT} variation with load current than Triacs and that is why they are more suitable for 3.3 V applications as the gate current variation is lower.

Refer to the AN2986 application note for further details and for gate resistor calculation.

5.3 Pulsed gate control and average gate current consumption

[Table 3](#) gives the initial gate current pulse widths for each AC switch, and the maximum pulse width that may be programmed to keep the overall consumption below the maximum capability of the VIPer16 supply.

Table 3. Application current consumption

Device	PCB label	Gate resistor [Ω]	I_{GT} ($T_j = 25\text{ °C}$) [mA]	I_{GT} ($T_j = 0\text{ °C}$) [mA]	Gate current pulse duration [ms]	Maximum average current [mA]	Max. gate current pulse duration (DC mode) [ms]
T1635H-6T	T1	30	35	50	1	5	N/A ⁽¹⁾
ACST1635-8FP	T2	30	35	50	1	5	N/A ⁽¹⁾
Z0109MA	T3	112	10	15	2	3	10
ACS108-8SA	ACS1	112	10	15	10	15	10
ACS108-8SA	ACS2	112	10	15	2	3	10
ACS108-8SA	ACS3	112	10	15	2	3	10

1. Device is controlled in phase angle control, long pulse is not desired.

Current consumption of the MCU and six signal LEDs, when turned ON, was estimated at 25 mA. Total current consumption of the board when all Triacs/AC switches are ON with maximum gate current pulse is 95 mA (T1 and T2 have 1 ms gate current pulse as described above).

6 Board immunity performances

6.1 Hardware and software features to increase immunity

Software features

Software features to improve board immunity are

- Filtering procedure for button and potentiometer control
- Software watchdog

Hardware features to improve board immunity are

- Input varistor
- ACS-ACST technology and Transil™ as an option for T1635H-6T
- 47 nF input X2 capacitor
- Noise suppressor circuits are implemented (10 nF X2 capacitor and 75 Ω resistor)
- R-C-R filter on gate implemented (RG/2, 10 nF, RG/2)

Layout golden rules for immunity improvement

- Power tracks far from signal tracks
- V_{SS} map
- Noise suppressor and R-C-R gate filter close to AC switches and Triacs
- Input MCU pins have implemented filter capacitor 10 nF
- Any branch in the V_{DD} map has implemented a capacitor to decrease the V_{DD} variation

6.2 Surge tests results

Standard IEC 61000-4-5 tests were performed with surge level of 2 kV, which is required for home appliances. Mains voltage used for the tests was 230 V_{rms}/50 Hz.

The ACST16 device is protected against overvoltage spikes up to 2 kV with implemented crowbar technology. See the ACST16 datasheet for further details.

ACS devices are protected against overvoltage spikes up to 2 kV with implemented crowbar technology. See the ACS108-8S datasheet for further details.

The Z01 Triac is protected thanks to the noise suppressor circuit and high impedance of the load (refer to the AN437 application note for snubber design).

The T1635H is protected with Transil P6KE400CA. This is a different implementation of the crowbar technology. The purpose here is to propose overvoltage protection with a crowbar technology. This method presents the advantage of not aging contrary to the varistor technology.

6.3 Burst tests results

6.3.1 Test procedure

Standard IEC 61000-4-4 tests were implemented. The tests were performed at a frequency of 100 kHz and power supply voltage of 254 Vrms/50 Hz. Parameters of the spikes: $T_d = 0.7$ ms, $T_r = 300$ ms. All affected couplings were tested. Spikes were applied against the plate and related polarity (+/-) and the mains wire is mentioned: L+, L-, N+, N-, LN+, LN-. The board was tested during OFF state (all AC switches were turned OFF).

Protective earth (PE) wire is not connected on the board which is why the couplings with PE were not tested.

6.3.2 Test results of the board without hardware modifications

The target voltage level of the board immunity against burst spikes was 4 kV without any influence on the board performance (class A).

MCU STM32F100C4T6B was not disturbed by the burst spikes up to 6 kV (class A). Burst spikes up to 8 kV caused the MCU to reset but it recovers without external intervention (class B). Reset procedure did not influence the immunity of the devices with higher immunity.

[Table 4](#) shows immunity level of the ACS/Triacs against the burst spikes. The immunity is defined by voltage level of spurious triggering.

Table 4. Immunity level of ACS/Triacs in class A

STEVAL-IHT005V2 V_{IN} 254 VAC - 50 Hz	L+	L-	N+	N-	LN+	LN-
T1635H (150 W light bulb load)	> 8 kV	> 8 kV	> 8 kV	> 8 kV	> 8 kV	> 8 kV
ACST16 (150 W light bulb load)	> 8 kV	> 8 kV	> 8 kV	> 8 kV	> 8 kV	> 8 kV
Z0109 (75 W light bulb load)	4.5 kV	4.1 kV	3.7 kV	4.6 kV	4.0 kV	3.7 kV
ACS1 (75 W light bulb load)	7.4 kV	6.7 kV	> 8 kV	7.1 kV	7.3 kV	7.0 kV
ACS2 (150 W light bulb load)	> 8 kV	> 8 kV	> 8 kV	> 8 kV	7.6 kV	7.1 kV
ACS3 (150 W light bulb load)	> 8 kV	> 8 kV	> 8 kV	> 8 kV	7.6 kV	7.1 kV

6.3.3 Input filter influence

A 47 nF, X2 capacitor is implemented as the input filter. To achieve 4 kV immunity against the burst spikes for all the AC switches, it was necessary to add two other X2 capacitors: 100 nF and 220 nF, as each of them influenced a different type of coupling. These two capacitors are not included on the STEVAL-IHT005V2 board as only Z0109 was below 4 kV level.

Table 5. IEC-61000-4-4 results with input filter modification

STEVAL-IHT005V2 V _{IN} 254 VAC - 50 Hz	2 kV	4 kV	6 kV	8 kV
+ L Standby	A	A	B	B
+ L ON + level 3 (5.2 ms)	A	A	B	B
+ N Standby	A	A	B	B
+ N ON + level 3 (5.2 ms)	A	A	B	B
+ L + N Standby	A	A	B	B
+ L + N ON + level 3 (5.2 ms)	A	A	B	B
- L Standby	A	A	B	B
- L ON + level 3 (5.2 ms)	A	A	B	B
- N Standby	A	A	B	B
- N ON + level 3 (5.2 ms)	A	A	B	B
- L + N Standby	A	A	B	B
- L + N ON + level 3 (5.2 ms)	A	A	B	B

Note:

- A. No changes in functionality. The board works properly, no reset occurring.
- B. Reset occurs, but the board recovers without external intervention.
- C. Application does not recover without external intervention.

Two states were tested. Standby mode, when all devices are OFF, and "ON + level 3" when all devices are turned ON: the devices controlled in full wave mode (T3, ACS1, ACS2, ACS3) are ON for the whole period and phase angle controlled devices (T1, T2) are ON at level 3 (5.2 ms delay after zero voltage crossing signal).

6.3.4 Noise suppressor influence

The noise suppressor circuit that consists of X2 capacitor 10 nF (C2, C12, C14, C19, C21, C23) and resistor 75 Ω (R13, R19, R28, R43, R51, R60) has significant influence on burst immunity of the devices, as shown in the tests results below (to compare with [Table 5](#) results).

Table 6. Immunity of the high power devices without RC noise suppressor

STEVAL-IHT005V2 V _{IN} 254 VAC - 50 Hz	L+	L-	N+	N-	LN+	LN-
T1635H (150 W light bulb load)	1.7 kV	1.6 kV	1.9 kV	1.7 kV	2.1 kV	1.7 kV
ACST16 (150 W light bulb load)	4.6 kV	3.5 kV	4.8 kV	3.1 kV	3.3 kV	3.1 kV

6.3.5 Gate filtering circuit influence

The gate filtering circuit has an influence mainly on sensitive devices. When the gate filtering circuit is removed, the immunity of Z01 decreases to 2 kV and immunity of ACS108 is decreased to 4 kV. Gate filtering circuit is not mandatory to pass IEC-61000-4-4 tests for ACS108.

There is no influence on 35 mA I_{GT} devices, when the gate filtering circuit is removed.

6.3.6 Immunity to relay switching

Relay is connected on the board. The relay cannot be controlled in zero voltage mode. Switching of the relay produces very high dV/dt, other devices must be immune to this type of noise. Immunity tests of the devices against relay switching have been performed.

Figure 7 shows turn-off behavior of the relay. (The dV/dt observed during turn-off is 1 kV/ μ s.) Observed peak voltage during turn-off was +/-1300 V. The dV/dt observed during turn-on was 4 kV/ μ s. The load was 1.4 H inductor with serial resistance 12 Ω , (RMS current 0.52 A). The Triacs and ACS/ACST switches were not disturbed by these spikes.

Figure 7. dV/dt behavior during relay turn-off

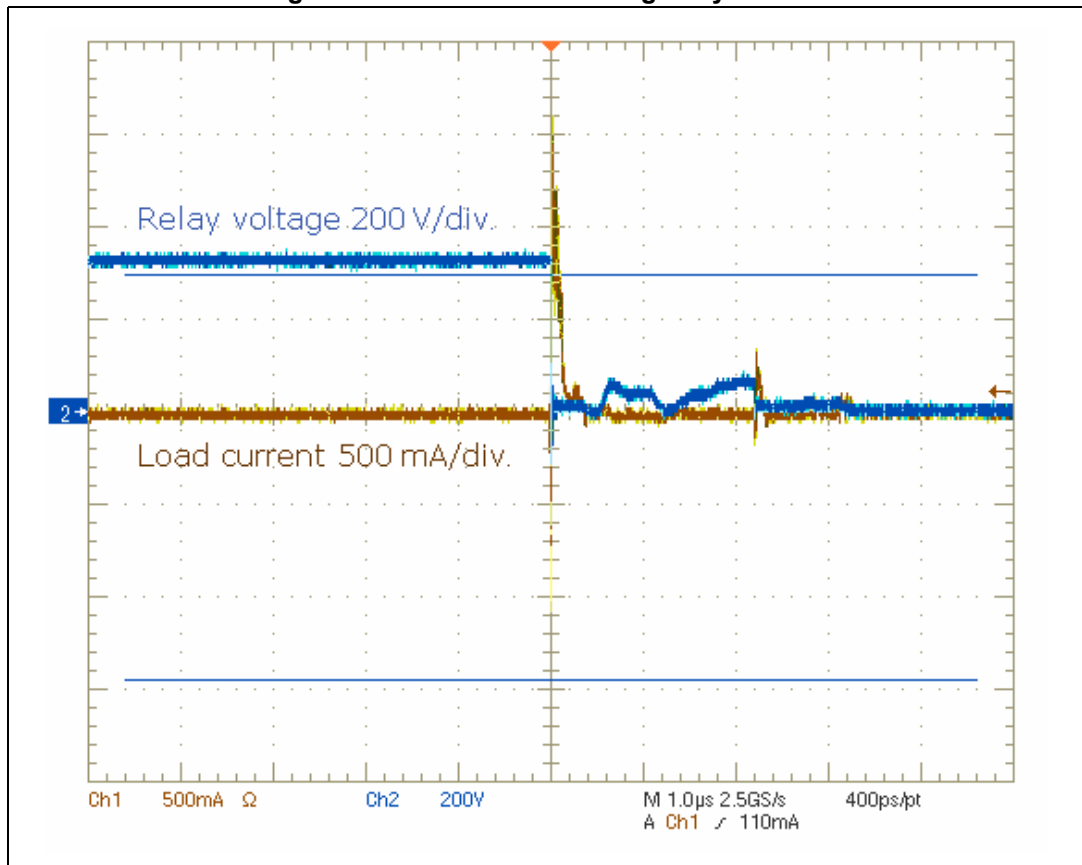
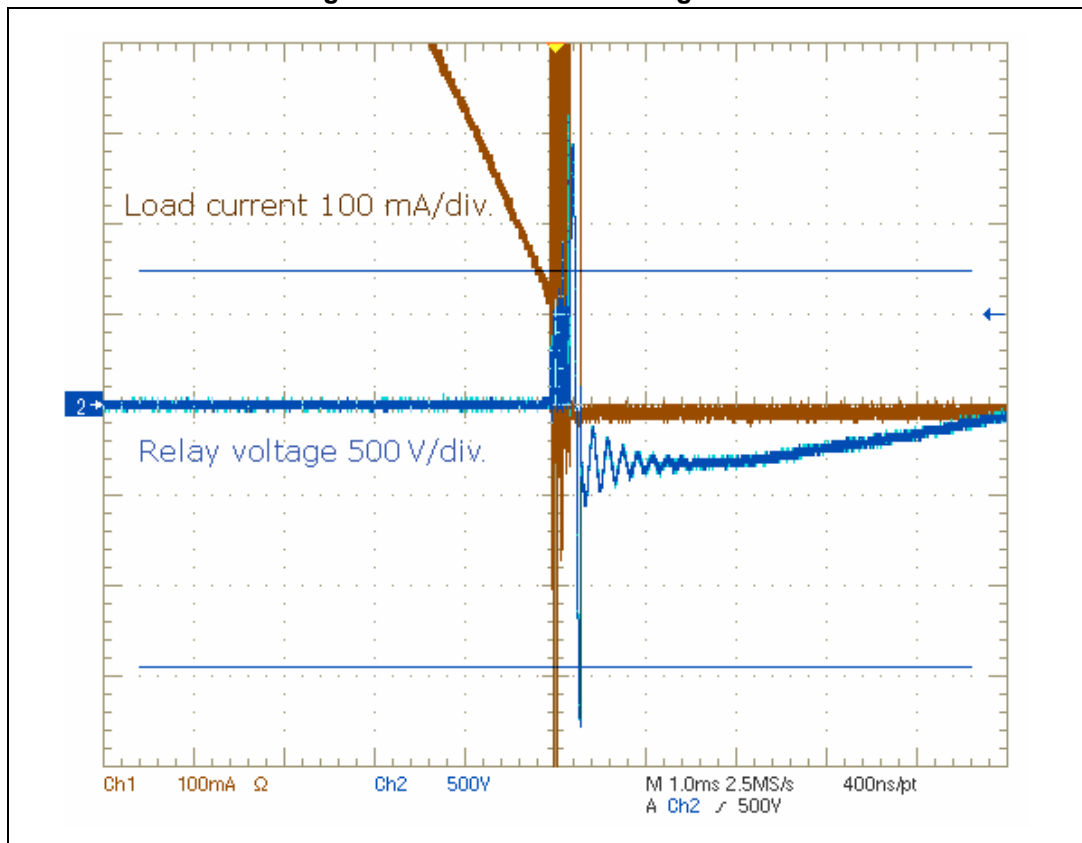

Figure 8. dV/dt behavior during turn-on



Appendix A STEVAL-IHT005V2 schematic

A.1 Schematic

Figure 9. STEVAL-IHT005V2 schematic

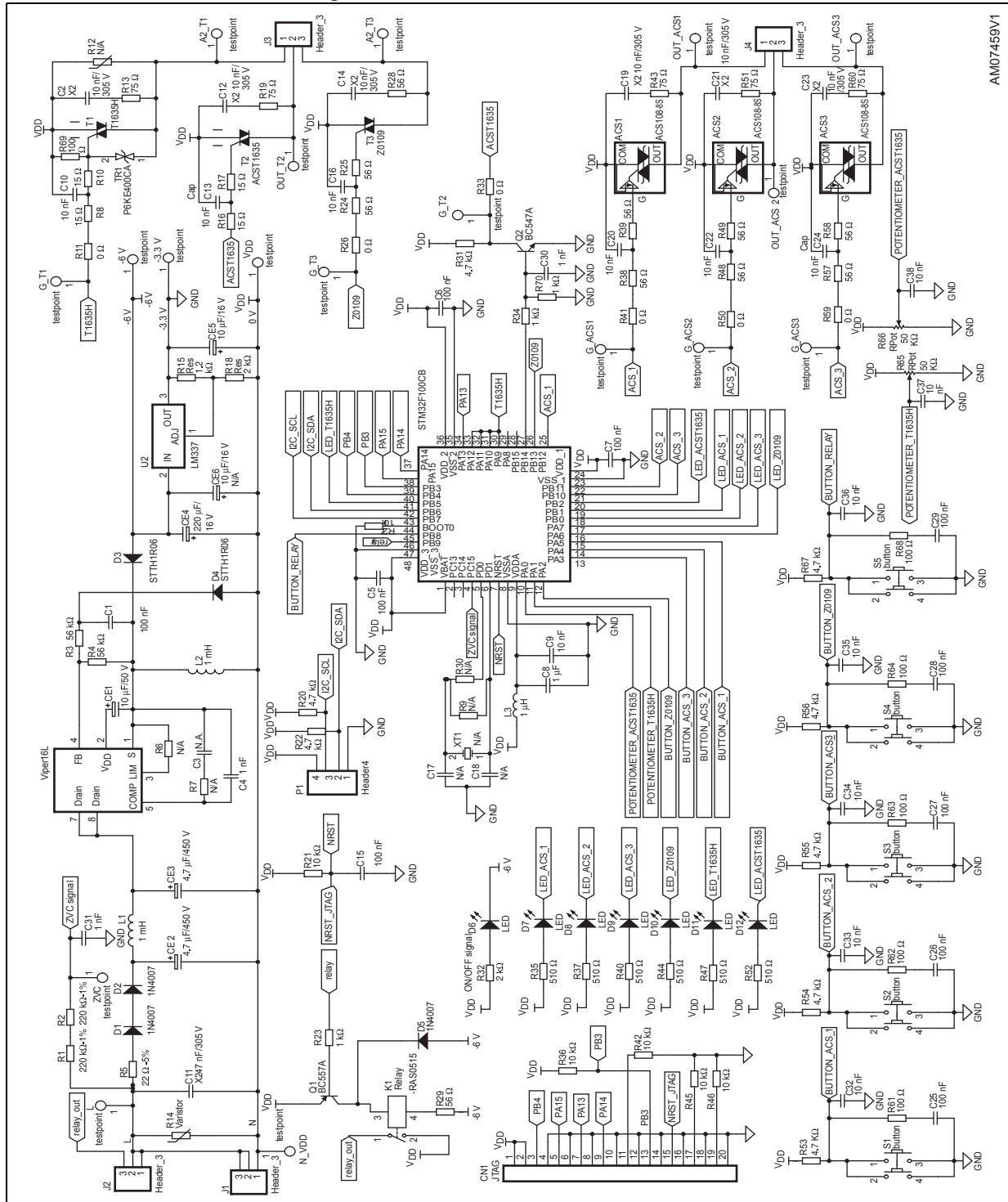

A.2 Demonstration board layout

Figure 10. STEVAL-IHT005V2 - top layer

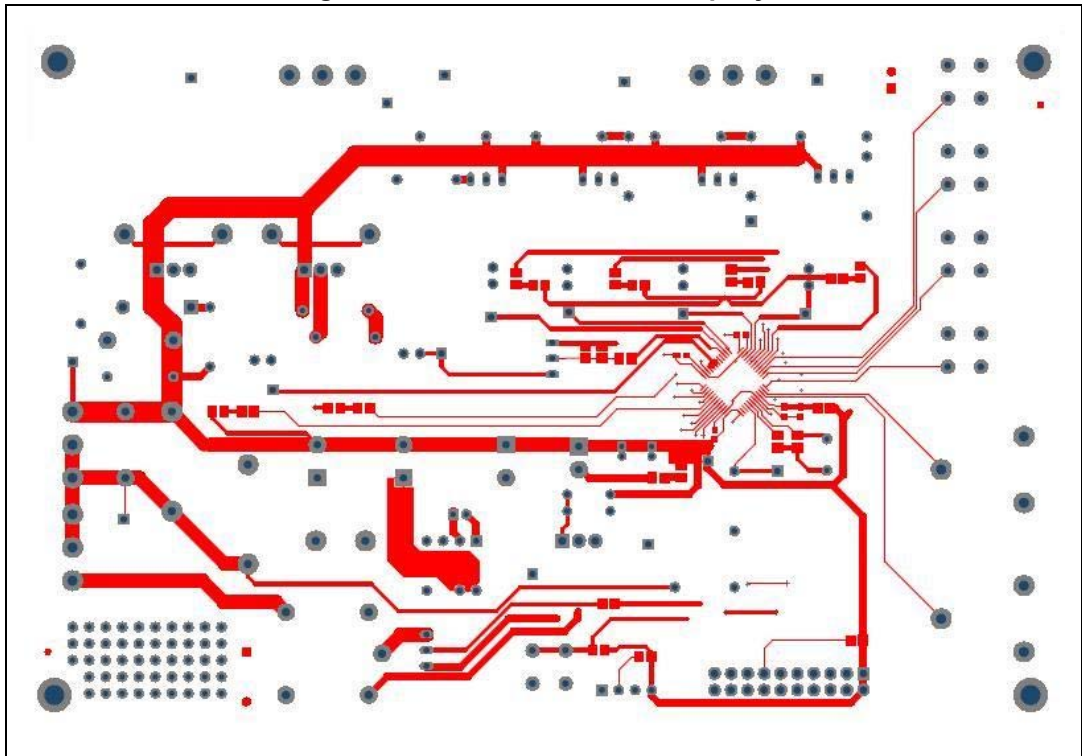
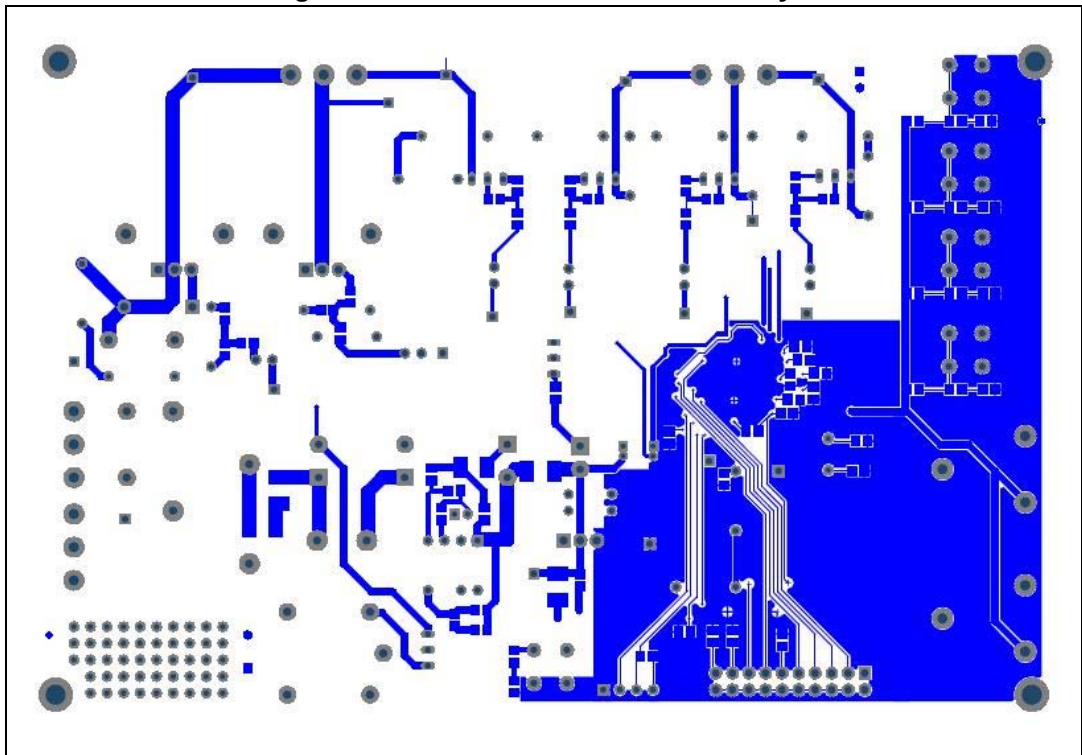

Figure 11. STEVAL-IHT005V2 - bottom layer



A.3 Test point lists

Table 7. Test points definition

Name	Definition
G_T1	Control signal of T1 (T1635H)
ZVC	"Zero Voltage Crossing" signal
-6 V	Reference of SMPS output voltage
N_VDD	Neutral reference and V _{DD}
-3.3 V	Reference for MCU power supply
A2_T1	A2 terminal of T1
VDD	MCU power supply voltage
OUT_T2	OUT terminal of T2 (ACST16)
G_T3	Control signal of T3 (Z0109)
A2_T3	A2 terminal of T3
G_T2	Control signal of T2 (ACST16)
G_ACS1	Control signal of ACS1
OUT_ACS1	OUT terminal of ACS1
G_ACS2	Control signal of ACS2
OUT_ACS2	OUT terminal of ACS2
G_ACS3	Control signal of ACS3
OUT_ACS3	OUT terminal of ACS3
Line	LINE voltage

A.4 Gate resistor calculation

The gate resistor value must be defined within the equation below to ensure to apply a gate current higher than specified I_{GT} for the worst operating conditions:

Gate resistor calculation

$$R_g \leq \frac{1}{\left(1 + \frac{R_{g-tol}}{100}\right)} \left(\frac{V_{DD-Min} - V_{GT-Max} - V_{OL}}{I_G(0^\circ C)} \right)$$

Assumptions for calculation

- V_{DD_Min} is minimum supply voltage (typically 3 V for 3.3 V power supply taking into account dispersion of resistors at LM337).
- $V_{GT_Max} = 1.0$ V (maximum gate voltage that must be applied between gate and A1 or COM).
- $V_{OL} = 0.4$ V maximum MCU I/O port voltage when turned to low level (given by the datasheet (0.4 V for STM32F100)).

Note: V_{OL} value of 0.4 V is used also for BC547B buffer transistor control.

- R_{g_tol} is tolerance of used resistor (typically 1% or 5%).
- $I_G(0\text{ }^{\circ}\text{C})$ is gate current for minimum ambient temperature (normally 0 °C) (refer to Triac family datasheet curve).

Standard resistor choices, according to the above equation and assumptions, are shown in [Table 8](#).

Table 8. Gate resistor definition for each device

	Tolerance of R_g (%)	R_g (Ω)	R_g standard (Ω)
T1635H	1	31.7	2 x 15
	5	30.4	2 x 15
ACST16	1	31.7	2 x 15
	5	30.4	2 x 15
ACS108	1	112.2	2 x 56
	5	107.8	2 x 51
Z0109	1	112.2	2 x 56
	5	107.8	2 x 51

In the STEVAL-IHT005V2 demonstration board tolerance resistors of 1% are used.

A.5 Bill of material

Table 9. Bill of material

Quantity	Designator	Value	Description	Vendor	Order code
1	C3	N/A	Capacitor		
1	P1	N/A	Header, 4-pin		
2	C17, C18	N/A	Capacitor		
2	R6, R7	N/A	Resistor		
2	R9, R30	N/A	Resistor		
1	C11	X2 47 nF/305 V	Capacitor	EPCOS	B32922C3473K000
6	C2, C12, C14, C19, C21, C23	X2 10 nF/305 V	Capacitor	EPCOS	B32921C3103K000
1	C1	100 nF/50 V 0805 SMD	Capacitor	Any	
3	C4, C30, C31	1 nF/50 V 0805 SMD	Capacitor	Any	
1	C8	1 μ F/16 V 0603 SMD	Capacitor	Any	
1	C9	10 nF/50 V 0603 SMD	Capacitor	Any	
1	CE1	10 μ F/50 V	Electrolytic capacitor	Any	
1	CE4	220 μ F/16 V	Electrolytic capacitor	Any	
1	CE5	10 μ F/16 V	Electrolytic capacitor	Any	
1	CE6	N/A	Electrolytic capacitor	Any	
1	CN2	MLW20G	Connector	Any	
1	D6	LED 0805 red 20 mA	Typical LED	Any	
1	K1	RAS 0515	Single-pole relay	Any	
1	L1	1 mH 0.13 A	Inductor	Any	
1	L2	1 mH 0.28 A	Inductor	Any	
1	L3	1 μ H 0805 SMD 0.09 A	Inductor	Any	
1	Q1	BC557A	PNP bipolar transistor	Any	
1	Q2	BC547A	NPN bipolar transistor	Any	
1	R12	N/A	Varistor	Any	
1	R14	595-275	Varistor	Any	
1	R15	1.2 k Ω 0.6 W	Resistor	Any	
1	R18	2 k Ω 0.6 W	Resistor	Any	
1	R28	56 Ω 0.6 W	Resistor	Any	
1	R31	4.7 k Ω 0.6 W	Resistor	Any	
1	R32	2 k Ω 0805 SMD	Resistor	Any	

Table 9. Bill of material (continued)

Quantity	Designator	Value	Description	Vendor	Order code
1	R5	22 Ω - 5% 2 W	Resistor	Any	
1	R69	100 Ω 0.6 W	Resistor	Any	
1	S1	P-DT6BL	Button	Any	
2	S2, S3	P-DT6SW	Button	Any	
1	S4	P-DT6WS	Button	Any	
1	S5	P-DT6RT	Button	Any	
1	XT1	N/A	Crystal oscillator (HC49/U 8 MHz)	Any	
2	CE2, CE3	4.7 μF/450 V	Electrolytic capacitor	Any	
2	R1, R2	220 kΩ - 1% 0.6 W	Resistor	Any	
2	R3, R4	56 kΩ 0805 SMD	Resistor	Any	
2	R65, R66	50 kΩ	Potentiometer + shaft	Any	
3	C5, C6, C7	100 nF/50 V 0603 SMD	Capacitor	Any	
3	D1, D2, D5	1N4007 SMA	Default diode	Any	
3	R23, R34, R70	1 kΩ 0805 SMD	Resistor	Any	
4	J1, J2, J3, J4	ARK300V-3P	Three-pole terminal	Any	
4	R8, R10, R16, R17	15 Ω 0805 SMD	Resistor	Any	
5	R13, R19, R43, R51, R60	75 Ω 0.6 W	Resistor	Any	
5	R61, R62, R63, R64, R68	100 Ω 0805 SMD	Resistor	Any	
6	C10, C13, C16, C20, C22, C24	10 nF/50 V 0805 SMD	Capacitor	Any	
6	C15, C25, C26, C27, C28, C29	100 nF/50 V 0805 SMD	Capacitor	Any	
6	D7, D8, D9, D10, D11, D12	LED 0805 green 20 mA	Typical LED	Any	
6	R11, R26, R33, R41, R50, R59	0R STIP line 2x + jumper	Short-circuit connector	Any	
6	R21, R27, R36, R42, R45, R46	10 kΩ 0805 SMD	Resistor	Any	
6	R35, R37, R40, R44, R47, R52	510 Ω 0805 SMD	Resistor	Any	
7	C32, C33, C34, C35, C36, C37, C38	10 nF/50 V 0805 SMD	Capacitor	Any	

Table 9. Bill of material (continued)

Quantity	Designator	Value	Description	Vendor	Order code
7	R20, R22, R53, R54, R55, R56, R67	4.7 k Ω 0805 SMD	Resistor	Any	
9	R24, R25, R29, R38, R39, R48, R49, R57, R58	56 Ω 0805 SMD	Resistor	Any	
18	-3V3, -6 V, A2_T1, A2_T3, G_ACS1, G_ACS2, G_ACS3, G_T1, G_T2, G_T3, L, N_VDD, OUT_ACS1, OUT_ACS2, OUT_ACS3, OUT_T2, VDD, ZVC	Test point	Test point	RS	262-2179
1	T1	16 A Triac	High temperature Triac	STMicroelectronics	T1635H-6T
1	T2	16 A ACST		ST	ACST1635-8FP
1	T3	1 A Triac	Standard 4Q Triac	ST	Z0109MA
1	TR1	P6KE400CA	Transil	ST	P6KE400CA
1	U1		Monolithic AC-DC converter	ST	VIPer16LN
1	U2		Voltage regulator	ST	LM337
1	U3		32-bit MCU	ST	STM32F100C4T6B
2	D3, D4		Fast diode	ST	STTH1R06
3	ACS1, ACS2, ACS3	0.8 A AC switch		ST	ACS108-8SA
2		20 x 20 x 30 mm ~6 K/W	Heatsink	Any	
4			Distance columns, 10 mm, KDI6M3X10	Any	
4			M3 screw, 6 mm long	Any	

Revision history

Table 10. Document revision history

Date	Revision	Changes
01-Oct-2013	1	Initial release.

Please Read Carefully:

Information in this document is provided solely in connection with ST products. STMicroelectronics NV and its subsidiaries ("ST") reserve the right to make changes, corrections, modifications or improvements, to this document, and the products and services described herein at any time, without notice.

All ST products are sold pursuant to ST's terms and conditions of sale.

Purchasers are solely responsible for the choice, selection and use of the ST products and services described herein, and ST assumes no liability whatsoever relating to the choice, selection or use of the ST products and services described herein.

No license, express or implied, by estoppel or otherwise, to any intellectual property rights is granted under this document. If any part of this document refers to any third party products or services it shall not be deemed a license grant by ST for the use of such third party products or services, or any intellectual property contained therein or considered as a warranty covering the use in any manner whatsoever of such third party products or services or any intellectual property contained therein.

UNLESS OTHERWISE SET FORTH IN ST'S TERMS AND CONDITIONS OF SALE ST DISCLAIMS ANY EXPRESS OR IMPLIED WARRANTY WITH RESPECT TO THE USE AND/OR SALE OF ST PRODUCTS INCLUDING WITHOUT LIMITATION IMPLIED WARRANTIES OF MERCHANTABILITY, FITNESS FOR A PARTICULAR PURPOSE (AND THEIR EQUIVALENTS UNDER THE LAWS OF ANY JURISDICTION), OR INFRINGEMENT OF ANY PATENT, COPYRIGHT OR OTHER INTELLECTUAL PROPERTY RIGHT.

ST PRODUCTS ARE NOT DESIGNED OR AUTHORIZED FOR USE IN: (A) SAFETY CRITICAL APPLICATIONS SUCH AS LIFE SUPPORTING, ACTIVE IMPLANTED DEVICES OR SYSTEMS WITH PRODUCT FUNCTIONAL SAFETY REQUIREMENTS; (B) AERONAUTIC APPLICATIONS; (C) AUTOMOTIVE APPLICATIONS OR ENVIRONMENTS, AND/OR (D) AEROSPACE APPLICATIONS OR ENVIRONMENTS. WHERE ST PRODUCTS ARE NOT DESIGNED FOR SUCH USE, THE PURCHASER SHALL USE PRODUCTS AT PURCHASER'S SOLE RISK, EVEN IF ST HAS BEEN INFORMED IN WRITING OF SUCH USAGE, UNLESS A PRODUCT IS EXPRESSLY DESIGNATED BY ST AS BEING INTENDED FOR "AUTOMOTIVE, AUTOMOTIVE SAFETY OR MEDICAL" INDUSTRY DOMAINS ACCORDING TO ST PRODUCT DESIGN SPECIFICATIONS. PRODUCTS FORMALLY ESCC, QML OR JAN QUALIFIED ARE DEEMED SUITABLE FOR USE IN AEROSPACE BY THE CORRESPONDING GOVERNMENTAL AGENCY.

Resale of ST products with provisions different from the statements and/or technical features set forth in this document shall immediately void any warranty granted by ST for the ST product or service described herein and shall not create or extend in any manner whatsoever, any liability of ST.

ST and the ST logo are trademarks or registered trademarks of ST in various countries.

Information in this document supersedes and replaces all information previously supplied.

The ST logo is a registered trademark of STMicroelectronics. All other names are the property of their respective owners.

© 2013 STMicroelectronics - All rights reserved

STMicroelectronics group of companies

Australia - Belgium - Brazil - Canada - China - Czech Republic - Finland - France - Germany - Hong Kong - India - Israel - Italy - Japan - Malaysia - Malta - Morocco - Philippines - Singapore - Spain - Sweden - Switzerland - United Kingdom - United States of America

www.st.com

