



STEVAL-ISA002V1

6W single output supply evaluation board using VIPer12A

Data Brief

Features

- Switch mode general purpose power supply
- Input: 85 to 264 VAC @ 50/60 Hz
- Output: 12V @ 0.5A
- Output power (peak): 6W
- Burst mode operation in standby for blue angel operation
- Switching frequency 60 kHz
- 75% efficiency
- Auxiliary undervoltage lockout with hysteresis
- Output short circuit protection
- Thermal shutdown protection
- Meets EN55022 Class B EMI specification

Applications

This evaluation board is an off-line wide range single output general-purpose power supply capable of delivering up to 6W of total output power. In low load condition, it operates in the automatic burst mode while in an overvoltage condition it will operate in hiccup mode.

Other output voltages can easily be achieved by changing the transformer and a few components on the board, as shown in the application note. Transformers are readily available for the following configurations:

- 5V @ 1.2A
- 12V @ 0.5A
- 15V @ 0.4A
- 24V @ 0.25A.



Description

When working in standby, the valuation board consumes less than 1W total power consumption and therefore, meets the "Blue Angel" norm. This unit operates in burst mode when the output load is reduced to zero and normal operation will resume automatically when the power gets back to a level higher than the standby power. The output voltage remains regulated even when the board operates in burst mode. The total power consumption measured at 115Vac input with zero load at output is approximately 168mW, while at 230Vac input this value is about 248mW. At 120Vac input, a minimum load of 52mA is needed to keep the input power consumption at less than 1W.

1 General circuit description

This evaluation board is designed as a discontinuous flyback regulator delivering 0.5A at 12V. The AC input is rectified and filtered by the bridge BR1, the bulk capacitor C1, and C2 to generate the high voltage DC bus applied to the primary winding (pins 8-10) of the transformer, TR1. C1, L1, and C2 provide EMI filtering for the circuit. R2 and C3 form the snubber circuit needed to reduce the leakage spike and voltage ringing on the drain pin of VIPer12A. The output voltage is regulated with a TL431 (U3) via an optocoupler (U2) to the feedback pin. The output voltage ripple is controlled with the capacitor, C7, with an additional LC PI filter configuration made up of L4 and C8. It is possible to modify the output voltages by changing the transformer turns ratio and modifying the resistance values of R6 and R7 in the feedback loop.

2 Board schematic

Figure 1. Scheme

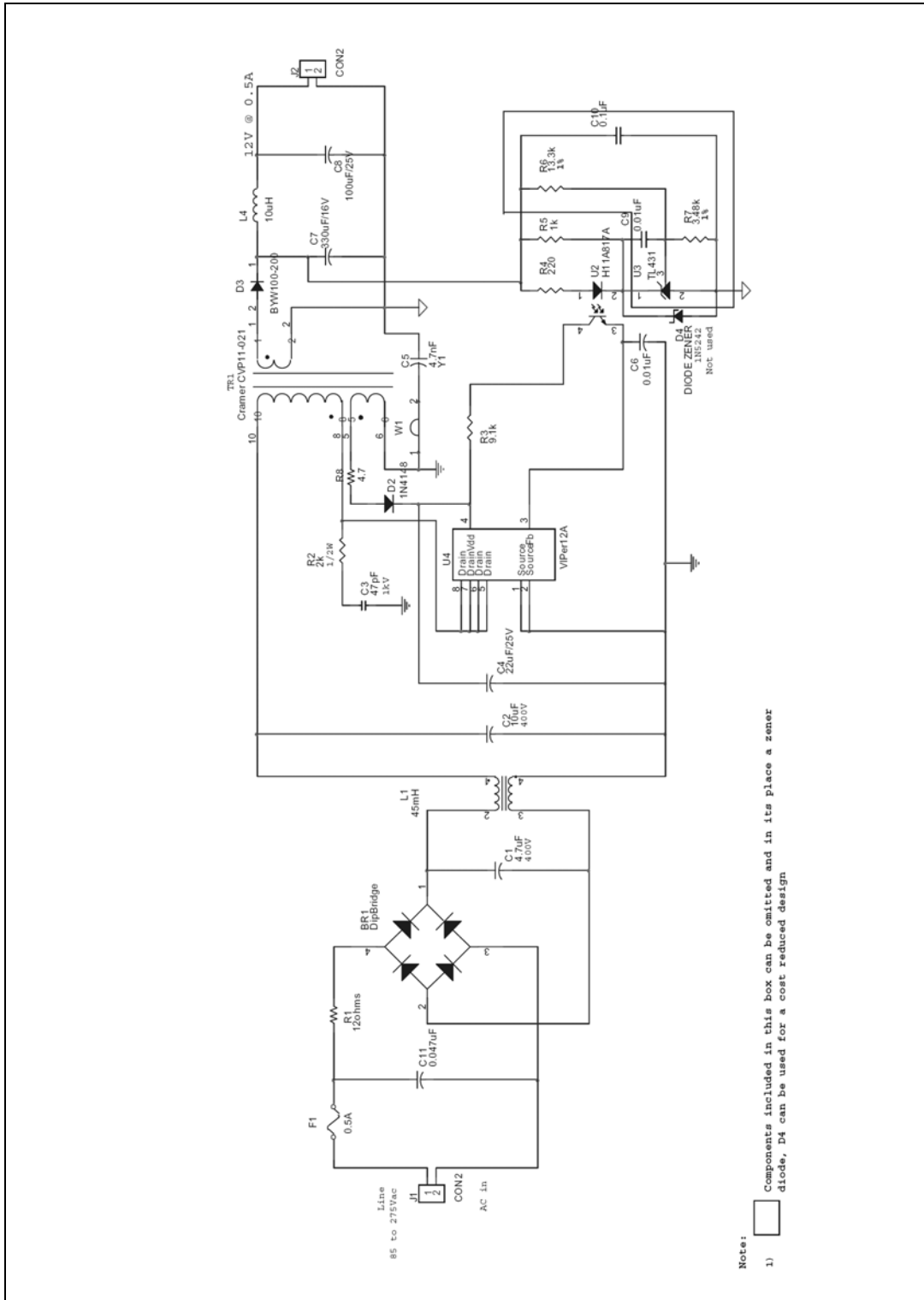

3 Revision history

Table 1. Document revision history

Date	Revision	Changes
20-Jul-2007	1	Initial release.

Please Read Carefully:

Information in this document is provided solely in connection with ST products. STMicroelectronics NV and its subsidiaries ("ST") reserve the right to make changes, corrections, modifications or improvements, to this document, and the products and services described herein at any time, without notice.

All ST products are sold pursuant to ST's terms and conditions of sale.

Purchasers are solely responsible for the choice, selection and use of the ST products and services described herein, and ST assumes no liability whatsoever relating to the choice, selection or use of the ST products and services described herein.

No license, express or implied, by estoppel or otherwise, to any intellectual property rights is granted under this document. If any part of this document refers to any third party products or services it shall not be deemed a license grant by ST for the use of such third party products or services, or any intellectual property contained therein or considered as a warranty covering the use in any manner whatsoever of such third party products or services or any intellectual property contained therein.

UNLESS OTHERWISE SET FORTH IN ST'S TERMS AND CONDITIONS OF SALE ST DISCLAIMS ANY EXPRESS OR IMPLIED WARRANTY WITH RESPECT TO THE USE AND/OR SALE OF ST PRODUCTS INCLUDING WITHOUT LIMITATION IMPLIED WARRANTIES OF MERCHANTABILITY, FITNESS FOR A PARTICULAR PURPOSE (AND THEIR EQUIVALENTS UNDER THE LAWS OF ANY JURISDICTION), OR INFRINGEMENT OF ANY PATENT, COPYRIGHT OR OTHER INTELLECTUAL PROPERTY RIGHT.

UNLESS EXPRESSLY APPROVED IN WRITING BY AN AUTHORIZED ST REPRESENTATIVE, ST PRODUCTS ARE NOT RECOMMENDED, AUTHORIZED OR WARRANTED FOR USE IN MILITARY, AIR CRAFT, SPACE, LIFE SAVING, OR LIFE SUSTAINING APPLICATIONS, NOR IN PRODUCTS OR SYSTEMS WHERE FAILURE OR MALFUNCTION MAY RESULT IN PERSONAL INJURY, DEATH, OR SEVERE PROPERTY OR ENVIRONMENTAL DAMAGE. ST PRODUCTS WHICH ARE NOT SPECIFIED AS "AUTOMOTIVE GRADE" MAY ONLY BE USED IN AUTOMOTIVE APPLICATIONS AT USER'S OWN RISK.

Resale of ST products with provisions different from the statements and/or technical features set forth in this document shall immediately void any warranty granted by ST for the ST product or service described herein and shall not create or extend in any manner whatsoever, any liability of ST.

ST and the ST logo are trademarks or registered trademarks of ST in various countries.

Information in this document supersedes and replaces all information previously supplied.

The ST logo is a registered trademark of STMicroelectronics. All other names are the property of their respective owners.

© 2007 STMicroelectronics - All rights reserved

STMicroelectronics group of companies

Australia - Belgium - Brazil - Canada - China - Czech Republic - Finland - France - Germany - Hong Kong - India - Israel - Italy - Japan - Malaysia - Malta - Morocco - Singapore - Spain - Sweden - Switzerland - United Kingdom - United States of America

www.st.com