

Qi A11 wireless charger transmitter evaluation board

Data brief

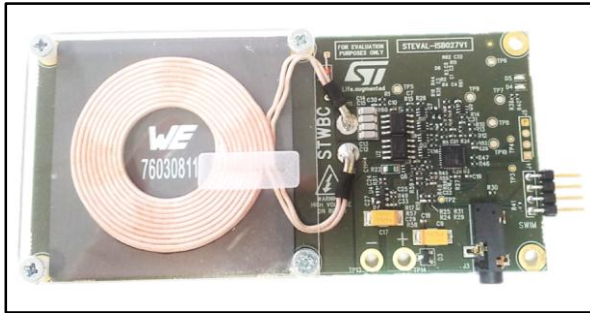

Description

The STEVAL-ISB027V1 is a Qi 5 Watt wireless battery charger transmitter evaluation board based on the STWBC digital controller for wireless battery charger transmitters. The solution is certified in accordance with the Qi standard, A11 topology. The STEVAL-ISB027V1 provides a complete kit which includes the STWBC IC, firmware, layout and tools. The layout is based on a cost-effective 2-layer PCB.

Tools for the STEVAL-ISB027V1 are available on www.st.com, and allow users to access run time information such as the current power delivered or the FOD status. The STWBC firmware offers users the flexibility to modify the behavior of the LEDs or GPIOs, while adding customizable I²C and UART communication.

Features

- STWBC digital controller
- 5 W output power
- Qi 1.1.2 A11 certified
- Foreign object detection (FOD)
- Resistive and capacitive modulation
- Active presence detector
- Turn-key & FW APIs
- complete kit (IC, firmware, tools)
- RoHS compliant

Figure 2: STEVAL-ISB027V1 circuit schematic (2 of 3)

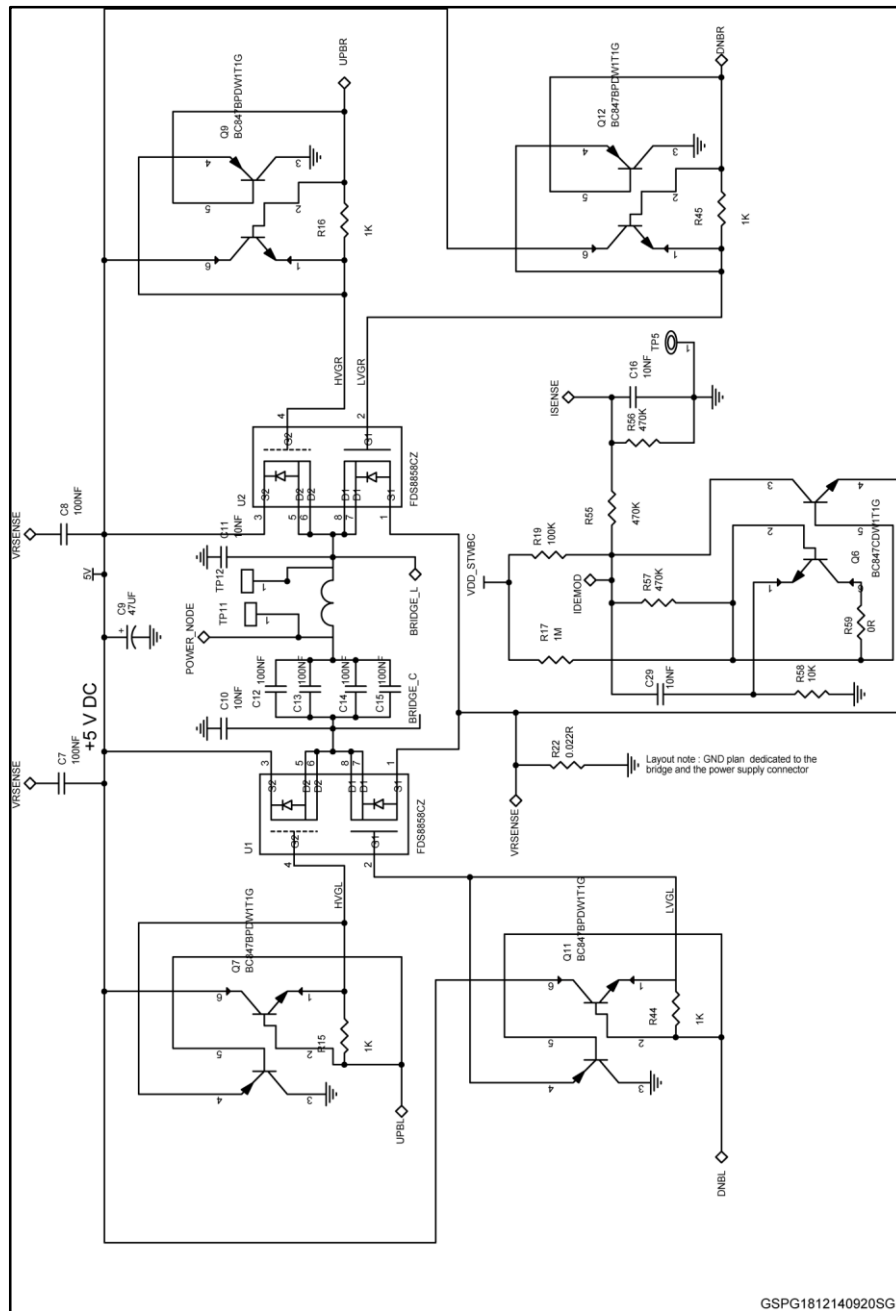
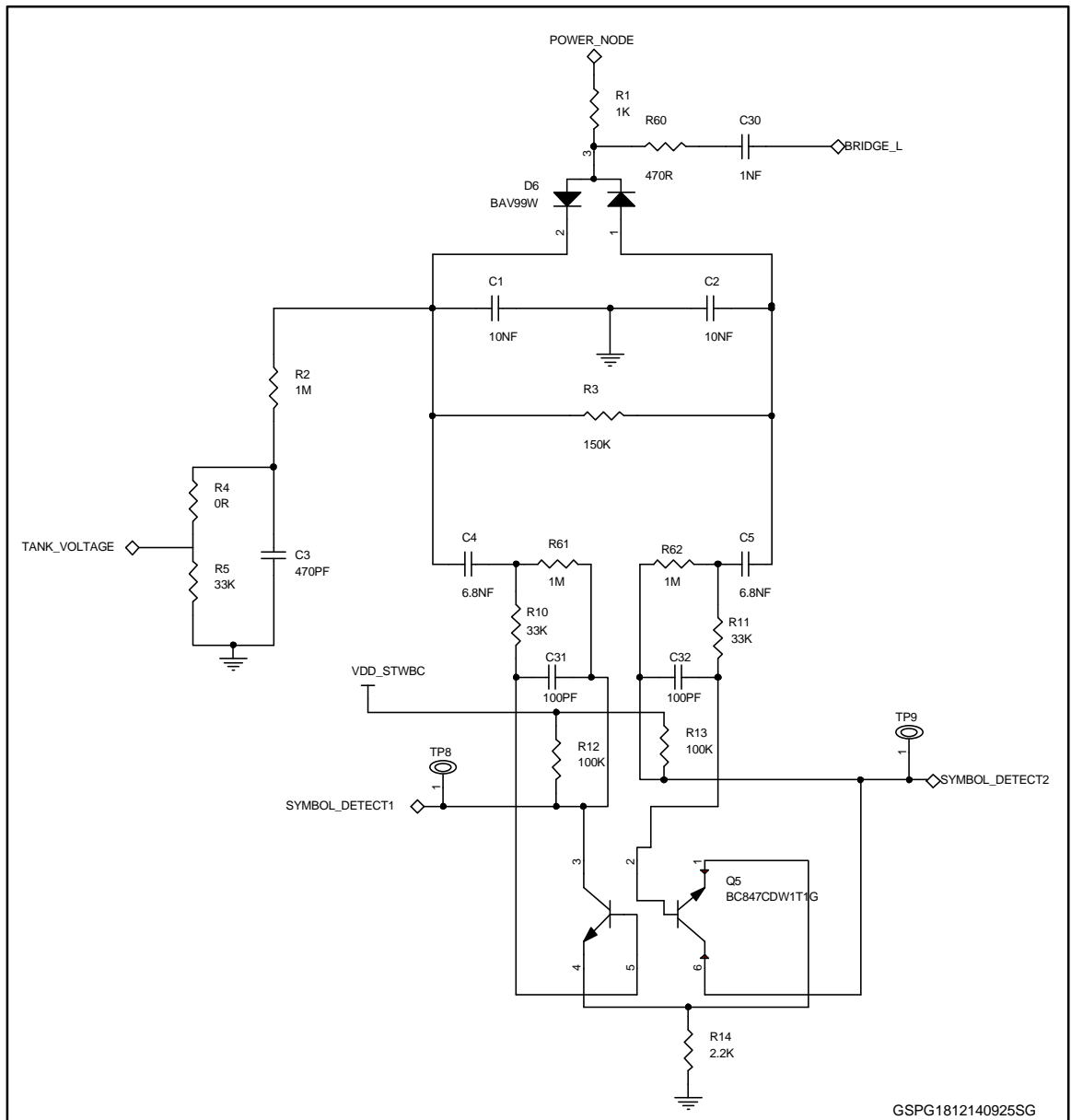

Figure 3: STEVAL-ISB027V1 circuit schematic (3 of 3)



GSPG1812140925SG

2 Revision history

Table 1: Document revision history

Date	Rev	Changes
18-Dec-2014	1	First release.

IMPORTANT NOTICE – PLEASE READ CAREFULLY

STMicroelectronics NV and its subsidiaries ("ST") reserve the right to make changes, corrections, enhancements, modifications, and improvements to ST products and/or to this document at any time without notice. Purchasers should obtain the latest relevant information on ST products before placing orders. ST products are sold pursuant to ST's terms and conditions of sale in place at the time of order acknowledgement.

Purchasers are solely responsible for the choice, selection, and use of ST products and ST assumes no liability for application assistance or the design of Purchasers' products.

No license, express or implied, to any intellectual property right is granted by ST herein.

Resale of ST products with provisions different from the information set forth herein shall void any warranty granted by ST for such product.

ST and the ST logo are trademarks of ST. All other product or service names are the property of their respective owners.

Information in this document supersedes and replaces information previously supplied in any prior versions of this document.

© 2014 STMicroelectronics – All rights reserved