



# STL120NH02V

N-channel 20 V - 0.0025  $\Omega$  - 120 A - PowerFLAT™ (6x5)  
STripFET™ III Power MOSFET

Preliminary Data

## Features

Type	V <sub>DSS</sub>	R <sub>DS(on)</sub>	I <sub>D</sub>
STL120NH02V	20 V	< 0.003 $\Omega$	28 A <sup>(1)</sup>

1. Value limited by wire bonding

- Improved die-to-footprint ratio
- Very low profile package (1mm max)
- Very low thermal resistance
- Conduction losses reduced
- 2.5V gate drive
- Switching losses reduced
- Very low threshold device

## Application

- Switching applications

## Description

The STL120NH02V utilizes the latest advanced design rules of ST's proprietary STripFET™ Technology. Thanks to a very low threshold, it is ideal for Synchronous Buck Converter in point of load brick module. The Chip-scaled PowerFLAT™ package allows a significant board space saving, still boosting the performance.

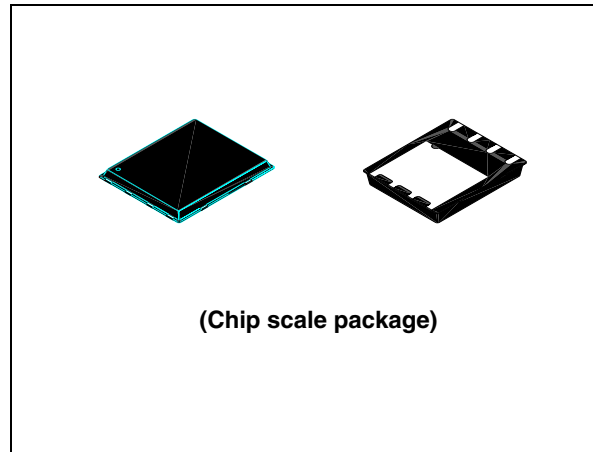

Figure 1. Internal schematic diagram

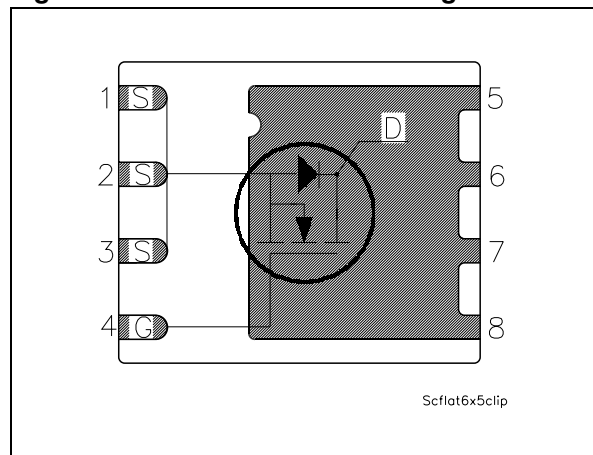

Table 1. Device summary

Order code	Marking	Package	Packaging
STL120NH02V	L120NH02V	PowerFLAT™ (6x5)	Tape & reel

## Contents

1	<b>Electrical ratings</b> .....	3
2	<b>Electrical characteristics</b> .....	4
3	<b>Test circuit</b> .....	6
4	<b>Package mechanical data</b> .....	7
5	<b>Revision history</b> .....	9

# 1 Electrical ratings

**Table 2. Absolute maximum ratings**

Symbol	Parameter	Value	Unit
$V_{DS}$	Drain-source voltage ( $V_{GS} = 0$ )	20	V
$V_{GS}$	Gate-source voltage	$\pm 8$	V
$I_D^{(1)}$	Drain current (continuous) at $T_C = 25\text{ }^\circ\text{C}$	120	A
$I_D^{(1)}$	Drain current (continuous) at $T_C = 100\text{ }^\circ\text{C}$	75	A
$I_{DM}^{(2)}$	Drain current (pulsed)	480	A
$I_D^{(3)}$	Drain current (continuous) at $T_C = 25\text{ }^\circ\text{C}$	28	A
$P_{TOT}^{(3)}$	Total dissipation at $T_C = 25\text{ }^\circ\text{C}$	4	W
$P_{TOT}^{(1)}$	Total dissipation at $T_C = 25\text{ }^\circ\text{C}$	80	W
	Derating factor <sup>(3)</sup>	0.03	W/ $^\circ\text{C}$
$T_j$ $T_{stg}$	Operating junction temperature storage temperature	-55 to 150	$^\circ\text{C}$

1. The value is rated according to Rthj-case
2. Pulse width limited by safe operating area
3. When mounted on FR-4 board of 1in<sup>2</sup>, 2oz Cu. t < 10 sec

**Table 3. Thermal data**

Symbol	Parameter	Value	Unit
Rthj-case	Thermal resistance junction-case (drain) (steady state)	1.56	$^\circ\text{C}/\text{W}$
Rthj-pcb <sup>(1)</sup>	Thermal resistance junction-pcb max	31.2	$^\circ\text{C}/\text{W}$

1. When mounted on FR-4 board of 1in<sup>2</sup>, 2oz Cu. t < 10 sec

**Table 4. Avalanche characteristics**

Symbol	Parameter	Max value	Unit
$I_{AR}$	Avalanche current, repetitive or not-repetitive (pulse width limited by $T_j$ max)	10	A
$E_{AS}$	Single pulse avalanche energy (starting $T_j = 25\text{ }^\circ\text{C}$ , $I_D = I_{AR}$ , $V_{DD} = 50\text{ V}$ )	2.8	mJ

## 2 Electrical characteristics

( $T_{CASE}=25^{\circ}\text{C}$  unless otherwise specified)

**Table 5. On/off states**

Symbol	Parameter	Test conditions	Min.	Typ.	Max.	Unit
$V_{(BR)DSS}$	Drain-source breakdown voltage	$I_D = 1 \text{ mA}, V_{GS} = 0$	20			V
$I_{DSS}$	Zero gate voltage drain current ( $V_{GS} = 0$ )	$V_{DS} = \text{max rating}$ $V_{DS} = \text{max rating},$ $T_C = 125^{\circ}\text{C}$			1 10	$\mu\text{A}$ $\mu\text{A}$
$I_{GSS}$	Gate-body leakage current ( $V_{DS} = 0$ )	$V_{GS} = \pm 8 \text{ V}$			$\pm 100$	nA
$V_{GS(th)}$	Gate threshold voltage	$V_{DS} = V_{GS}, I_D = 250 \mu\text{A}$	0.60			V
$R_{DS(on)}$	Static drain-source on resistance	$V_{GS} = 4.5 \text{ V}, I_D = 14 \text{ A}$ $V_{GS} = 2.5 \text{ V}, I_D = 14 \text{ A}$		0.0025 0.003	0.003 0.004	$\Omega$ $\Omega$

**Table 6. Dynamic**

Symbol	Parameter	Test conditions	Min.	Typ.	Max.	Unit
$C_{iss}$	Input capacitance	$V_{DS} = 25 \text{ V}, f = 1 \text{ MHz},$ $V_{GS} = 0$		6400		pF
$C_{oss}$	Output capacitance			1203		pF
$C_{rss}$	Reverse transfer capacitance			85		pF
$t_{d(on)}$	Turn-on delay time	$V_{DD} = 10 \text{ V}, I_D = 28 \text{ A}$ $R_G = 4.7 \Omega, V_{GS} = 2.3 \text{ V}$ (see <a href="#">Figure 2</a> )		44		ns
$t_r$	Rise time			140		ns
$t_{d(off)}$	Turn-off delay time			62		ns
$t_f$	Fall time			23		ns
$Q_g$	Total gate charge	$V_{DD} = 10 \text{ V}, I_D = 28 \text{ A},$ $V_{GS} = 2.5 \text{ V}$ (see <a href="#">Figure 3</a> )		26.5	44	nC
$Q_{gs}$	Gate-source charge			11.6		nC
$Q_{gd}$	Gate-drain charge			11.8		nC

Table 7. Source drain diode

Symbol	Parameter	Test conditions	Min.	Typ.	Max.	Unit
$I_{SD}$ $I_{SDM}^{(1)}$	Source-drain current Source-drain current (pulsed)				28 112	A A
$V_{SD}^{(2)}$	Forward on voltage	$I_{SD} = 28 \text{ A}$ , $V_{GS} = 0$			1.1	V
$t_{rr}$ $Q_{rr}$ $I_{RRM}$	Reverse recovery time Reverse recovery charge Reverse recovery current	$I_{SD} = 28 \text{ A}$ , $di/dt = 100 \text{ A}/\mu\text{s}$ , $V_{DD} = 13 \text{ V}$ (see <a href="#">Figure 4</a> )		47 61 2.6		ns nC A
$t_{rr}$ $Q_{rr}$ $I_{RRM}$	Reverse recovery time Reverse recovery charge Reverse recovery current	$I_{SD} = 28 \text{ A}$ , $di/dt = 100 \text{ A}/\mu\text{s}$ , $V_{DD} = 13 \text{ V}$ , $T_j = 150 \text{ }^\circ\text{C}$ (see <a href="#">Figure 4</a> )		48.3 65 2.7		ns nC A

1. Pulse width limited by safe operating area.
2. Pulsed: Pulse duration = 300  $\mu\text{s}$ , duty cycle 1.5%

### 3 Test circuit

**Figure 2. Switching times test circuit for resistive load**

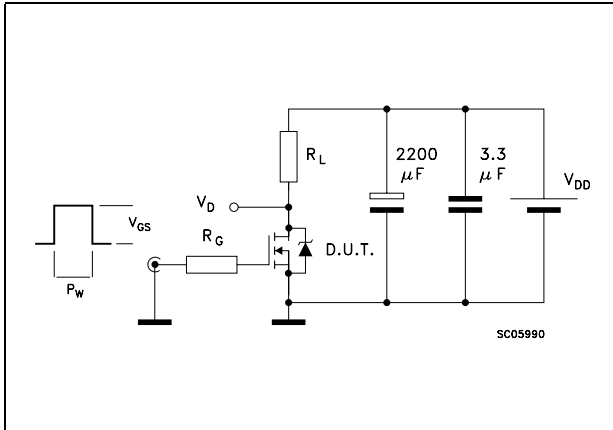

**Figure 3. Gate charge test circuit**

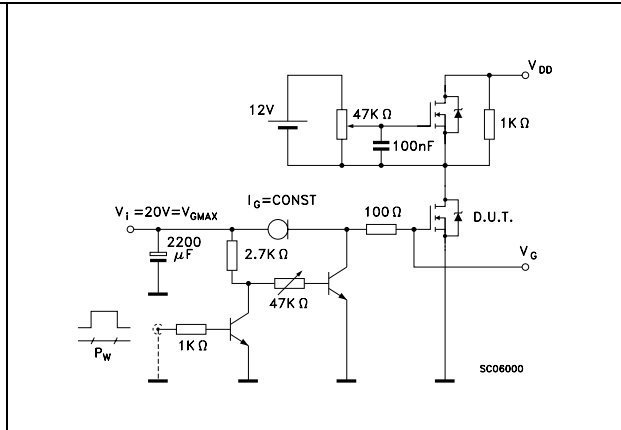

**Figure 4. Test circuit for inductive load switching and diode recovery times**

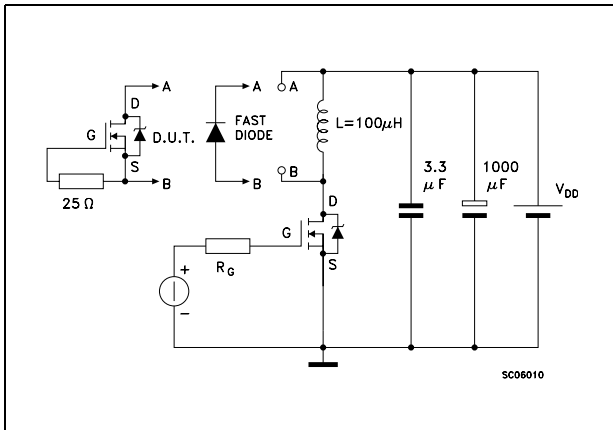

**Figure 5. Unclamped Inductive load test circuit**

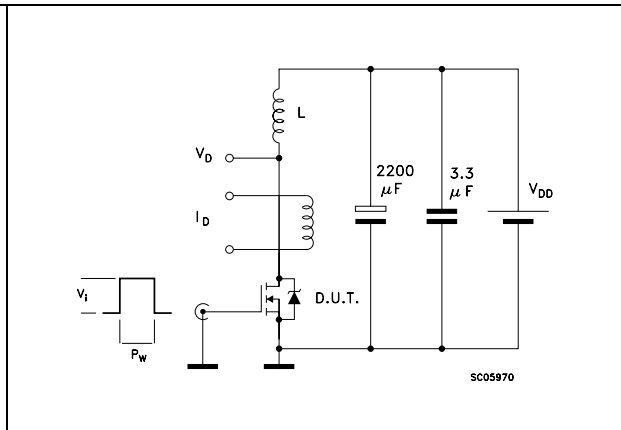

**Figure 6. Unclamped inductive waveform**

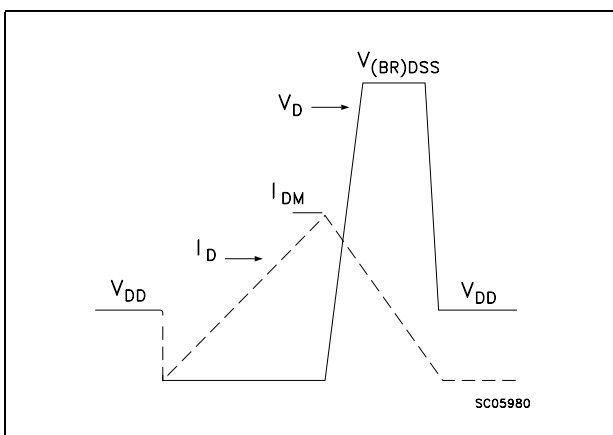

**Figure 7. Switching time waveform**

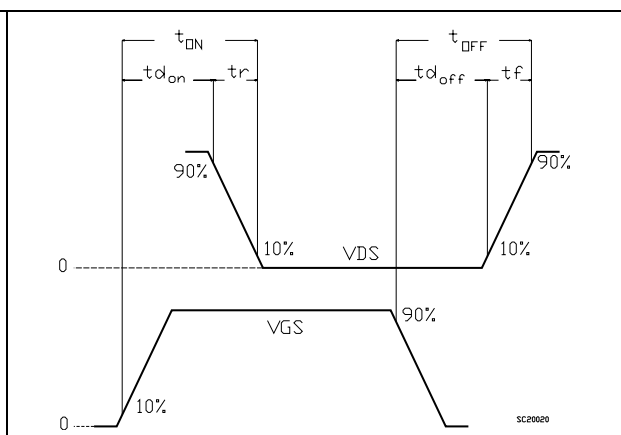

## 4 Package mechanical data

In order to meet environmental requirements, ST offers these devices in ECOPACK® packages. These packages have a Lead-free second level interconnect. The category of second level interconnect is marked on the package and on the inner box label, in compliance with JEDEC Standard JESD97. The maximum ratings related to soldering conditions are also marked on the inner box label. ECOPACK is an ST trademark. ECOPACK specifications are available at: [www.st.com](http://www.st.com)

**PowerFLAT™ (6x5) MECHANICAL DATA**

DIM.	mm.			inch		
	MIN.	TYP.	MAX.	MIN.	TYP.	MAX.
A	0.80	0.83	0.93	0.031	0.032	0.036
A1		0.02	0.05		0.0007	0.0019
A3		0.20			0.007	
b	0.35	0.40	0.47	0.013	0.015	0.018
D		5.00			0.196	
D1		4.75			0.187	
D2	4.15	4.20	4.25	0.163	0.165	0.167
E		6.00			0.236	
E1		5.75			0.226	
E2	3.43	3.48	3.53	0.135	0.137	0.139
E4	2.58	2.63	2.68		0.103	0.105
e		1.27			0.050	
L	0.70	0.80	0.90	0.027	0.031	0.035

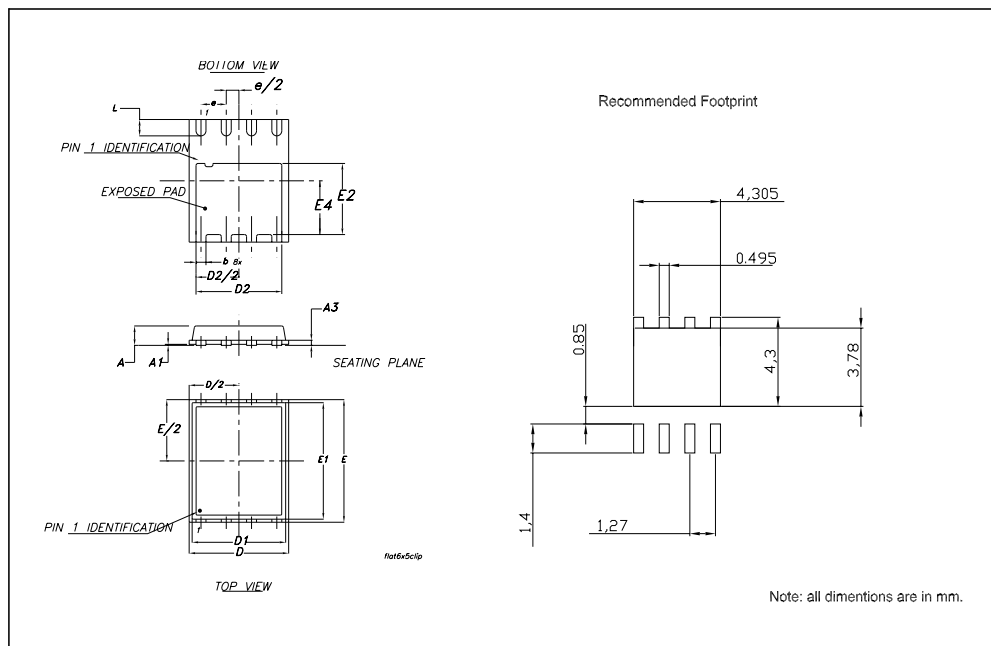

## 5 Revision history

**Table 8. Document revision history**

<b>Date</b>	<b>Revision</b>	<b>Changes</b>
24-Jun-2005	1	New document
04-Sep-2006	2	Document reformatted, no content change
14-Dec-2007	3	Document status promoted from target specification to preliminary data.

**Please Read Carefully:**

Information in this document is provided solely in connection with ST products. STMicroelectronics NV and its subsidiaries ("ST") reserve the right to make changes, corrections, modifications or improvements, to this document, and the products and services described herein at any time, without notice.

All ST products are sold pursuant to ST's terms and conditions of sale.

Purchasers are solely responsible for the choice, selection and use of the ST products and services described herein, and ST assumes no liability whatsoever relating to the choice, selection or use of the ST products and services described herein.

No license, express or implied, by estoppel or otherwise, to any intellectual property rights is granted under this document. If any part of this document refers to any third party products or services it shall not be deemed a license grant by ST for the use of such third party products or services, or any intellectual property contained therein or considered as a warranty covering the use in any manner whatsoever of such third party products or services or any intellectual property contained therein.

**UNLESS OTHERWISE SET FORTH IN ST'S TERMS AND CONDITIONS OF SALE ST DISCLAIMS ANY EXPRESS OR IMPLIED WARRANTY WITH RESPECT TO THE USE AND/OR SALE OF ST PRODUCTS INCLUDING WITHOUT LIMITATION IMPLIED WARRANTIES OF MERCHANTABILITY, FITNESS FOR A PARTICULAR PURPOSE (AND THEIR EQUIVALENTS UNDER THE LAWS OF ANY JURISDICTION), OR INFRINGEMENT OF ANY PATENT, COPYRIGHT OR OTHER INTELLECTUAL PROPERTY RIGHT.**

**UNLESS EXPRESSLY APPROVED IN WRITING BY AN AUTHORIZED ST REPRESENTATIVE, ST PRODUCTS ARE NOT RECOMMENDED, AUTHORIZED OR WARRANTED FOR USE IN MILITARY, AIR CRAFT, SPACE, LIFE SAVING, OR LIFE SUSTAINING APPLICATIONS, NOR IN PRODUCTS OR SYSTEMS WHERE FAILURE OR MALFUNCTION MAY RESULT IN PERSONAL INJURY, DEATH, OR SEVERE PROPERTY OR ENVIRONMENTAL DAMAGE. ST PRODUCTS WHICH ARE NOT SPECIFIED AS "AUTOMOTIVE GRADE" MAY ONLY BE USED IN AUTOMOTIVE APPLICATIONS AT USER'S OWN RISK.**

Resale of ST products with provisions different from the statements and/or technical features set forth in this document shall immediately void any warranty granted by ST for the ST product or service described herein and shall not create or extend in any manner whatsoever, any liability of ST.

ST and the ST logo are trademarks or registered trademarks of ST in various countries.

Information in this document supersedes and replaces all information previously supplied.

The ST logo is a registered trademark of STMicroelectronics. All other names are the property of their respective owners.

© 2007 STMicroelectronics - All rights reserved

STMicroelectronics group of companies

Australia - Belgium - Brazil - Canada - China - Czech Republic - Finland - France - Germany - Hong Kong - India - Israel - Italy - Japan - Malaysia - Malta - Morocco - Singapore - Spain - Sweden - Switzerland - United Kingdom - United States of America

[www.st.com](http://www.st.com)