



STN749

MEDIUM CURRENT, HIGH PERFORMANCE, LOW VOLTAGE PNP TRANSISTOR

Ordering Code	Marking
STN749	N749

- VERY LOW COLLECTOR TO EMITTER SATURATION VOLTAGE
- DC CURRENT GAIN, $h_{FE} > 100$
- 3 A CONTINUOUS COLLECTOR CURRENT
- SOT-223 PLASTIC PACKAGE FOR SURFACE MOUNTING CIRCUITS
- AVAILABLE IN TAPE AND REEL PACKING

APPLICATIONS

- POWER MANAGEMENT IN PORTABLE EQUIPMENT
- VOLTAGE REGULATION IN BIAS SUPPLY CIRCUITS
- SWITCHING REGULATOR IN BATTERY CHARGER APPLICATIONS
- HEAVY LOAD DRIVER

DESCRIPTION

The device is manufactured in low voltage PNP Planar Technology by using a "Base Island" layout.

The resulting Transistor shows exceptional high gain performance coupled with very low saturation voltage.

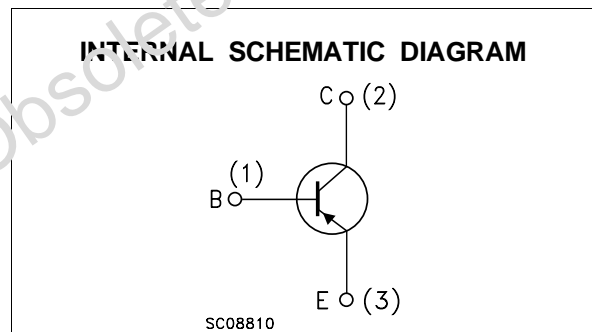
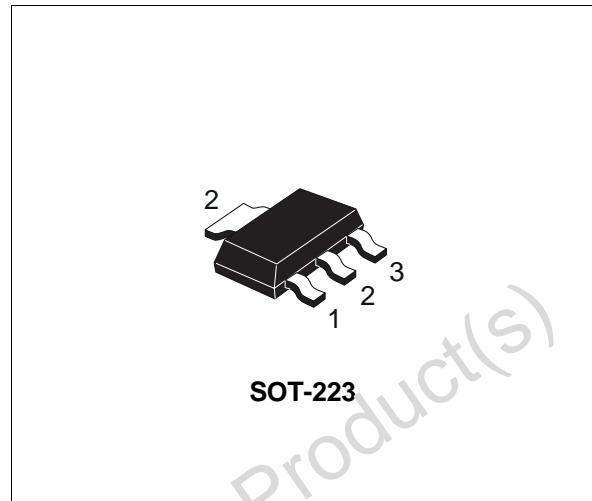

ABSOLUTE MAXIMUM RATINGS

Symbol	Parameter	Value	Unit
V_{CBO}	Collector-Base Voltage ($I_E = 0$)	-35	V
V_{CEO}	Collector-Emitter Voltage ($I_B = 0$)	-25	V
V_{EBO}	Emitter-Base Voltage ($I_C = 0$)	-5	V
I_C	Collector Current	-3	A
I_{CM}	Collector Peak Current ($t_p < 5$ ms)	-6	A
P_{tot}	Total Dissipation at $T_{amb} = 25$ °C	1.6	W
T_{stg}	Storage Temperature	-65 to 150	°C
T_j	Max. Operating Junction Temperature	150	°C

STN749

THERMAL DATA

$R_{thj-amb}$	Thermal Resistance Junction-Ambient	Max	78	$^{\circ}\text{C}/\text{W}$
---------------	-------------------------------------	-----	----	-----------------------------

• Device mounted on a PCB area of 1 cm^2 .

ELECTRICAL CHARACTERISTICS ($T_{case} = 25\text{ }^{\circ}\text{C}$ unless otherwise specified)

Symbol	Parameter	Test Conditions	Min.	Typ.	Max.	Unit
I_{CBO}	Collector Cut-off Current ($I_E = 0$)	$V_{CB} = -30\text{ V}$ $V_{CB} = -30\text{ V}$ $T_j = 100\text{ }^{\circ}\text{C}$			-100 -10	nA μA
I_{EBO}	Emitter Cut-off Current ($I_C = 0$)	$V_{EB} = -4\text{ V}$			-100	nA
$V_{(BR)CEO}^*$	Collector-Emitter Breakdown Voltage ($I_B = 0$)	$I_C = -10\text{ mA}$	-25			V
$V_{(BR)CBO}$	Collector-Base Breakdown Voltage ($I_E = 0$)	$I_C = -100\text{ }\mu\text{A}$	-35			V
$V_{(BR)EBO}$	Emitter-Base Breakdown Voltage ($I_C = 0$)	$I_E = -100\text{ }\mu\text{A}$	-5			V
$V_{CE(sat)}^*$	Collector-Emitter Saturation Voltage	$I_C = -1\text{ A}$ $I_B = -100\text{ mA}$ $I_C = -3\text{ A}$ $I_B = -300\text{ mA}$			-0.3 -0.6	V V
$V_{BE(sat)}^*$	Base-Emitter Saturation Voltage	$I_C = -1\text{ A}$ $I_B = -100\text{ mA}$			-1.25	V
$V_{BE(on)}$	Base-Emitter Turn-On Voltage	$I_C = -1\text{ A}$ $V_{CE} = -2\text{ V}$			-1	V
h_{FE}^*	DC Current Gain	$I_C = -50\text{ mA}$ $V_{CE} = -2\text{ V}$ $I_C = -1\text{ A}$ $V_{CE} = -2\text{ V}$ $I_C = -2\text{ A}$ $V_{CE} = -2\text{ V}$ $I_C = -6\text{ A}$ $V_{CE} = -2\text{ V}$	70 100 75 15		300	

* Pulsed: Pulse duration = $300\text{ }\mu\text{s}$, duty cycle $\leq 1.5\%$

DC Current Gain

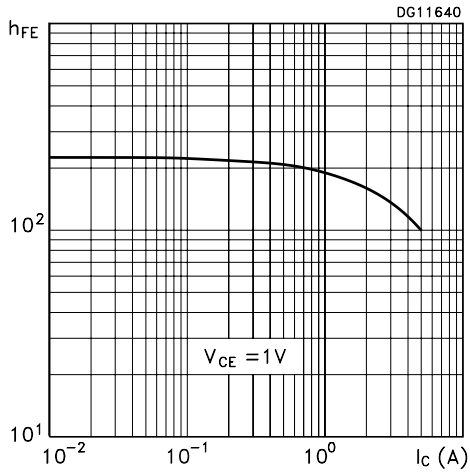

DC Current Gain

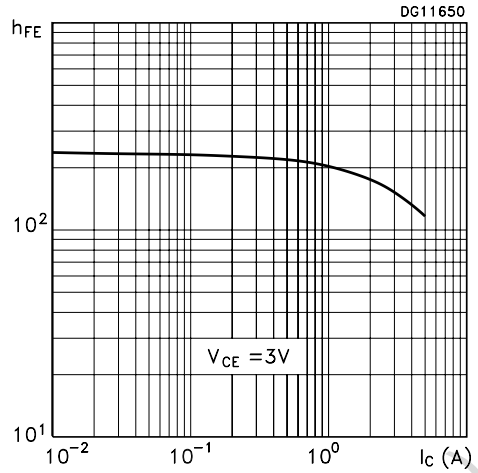

Collector-Emitter Saturation Voltage

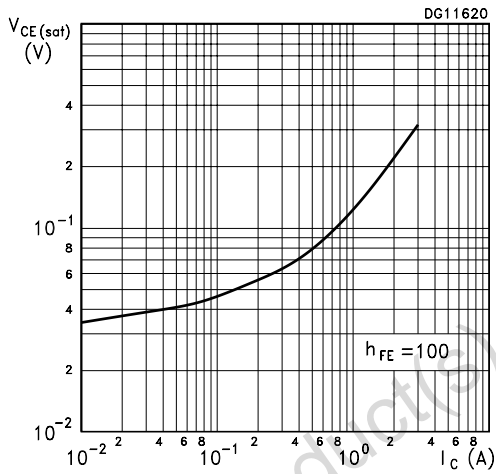

Base-Emitter Saturation Voltage

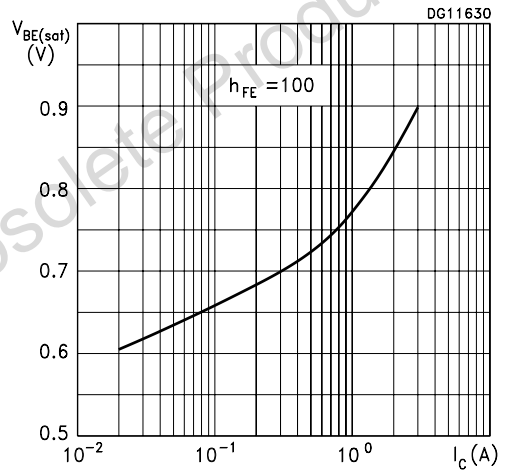

Switching Times Resistive Load

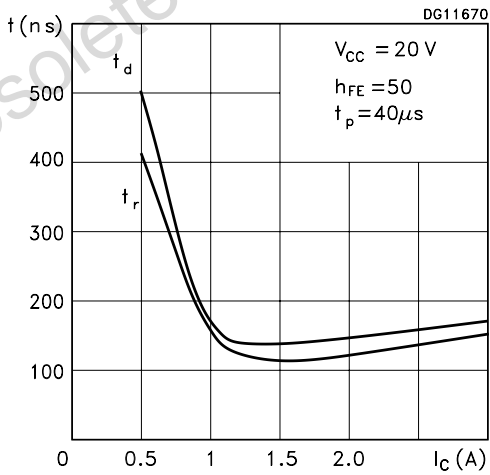

Switching Times Resistive Load

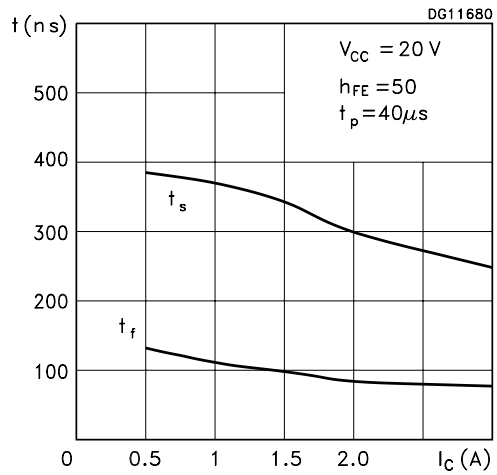
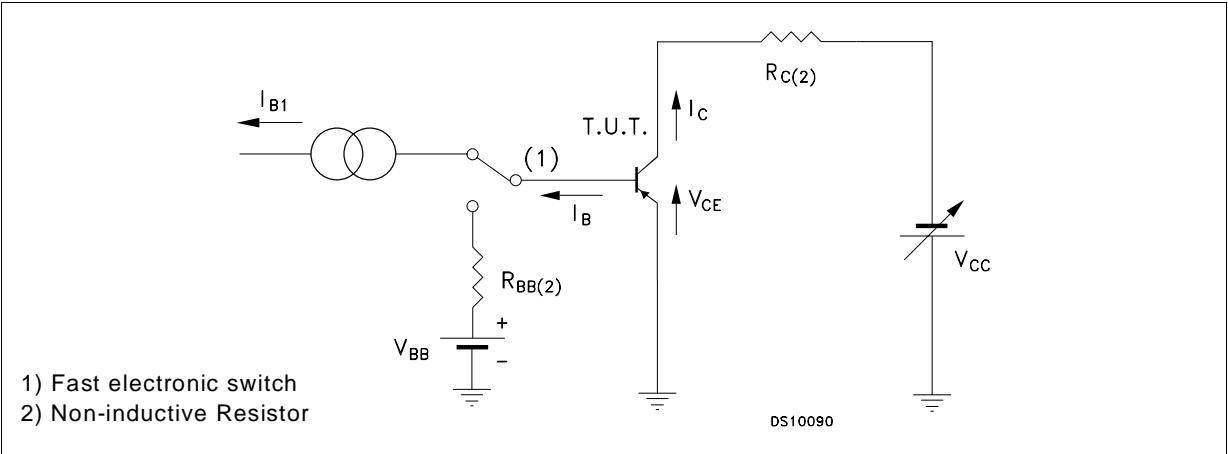

Figure 1: Resistive Load Switching Test Circuit.



Obsolete Product(s) - Obsolete Product(s)

SOT-223 MECHANICAL DATA

DIM.	mm			inch		
	MIN.	TYP.	MAX.	MIN.	TYP.	MAX.
A			1.80			0.071
B	0.60	0.70	0.80	0.024	0.027	0.031
B1	2.90	3.00	3.10	0.114	0.118	0.122
c	0.24	0.26	0.32	0.009	0.010	0.013
D	6.30	6.50	6.70	0.248	0.256	0.264
e		2.30			0.090	
e1		4.60			0.181	
E	3.30	3.50	3.70	0.130	0.138	0.146
H	6.70	7.00	7.30	0.264	0.276	0.287
V			10°			10°
A1		0.02				

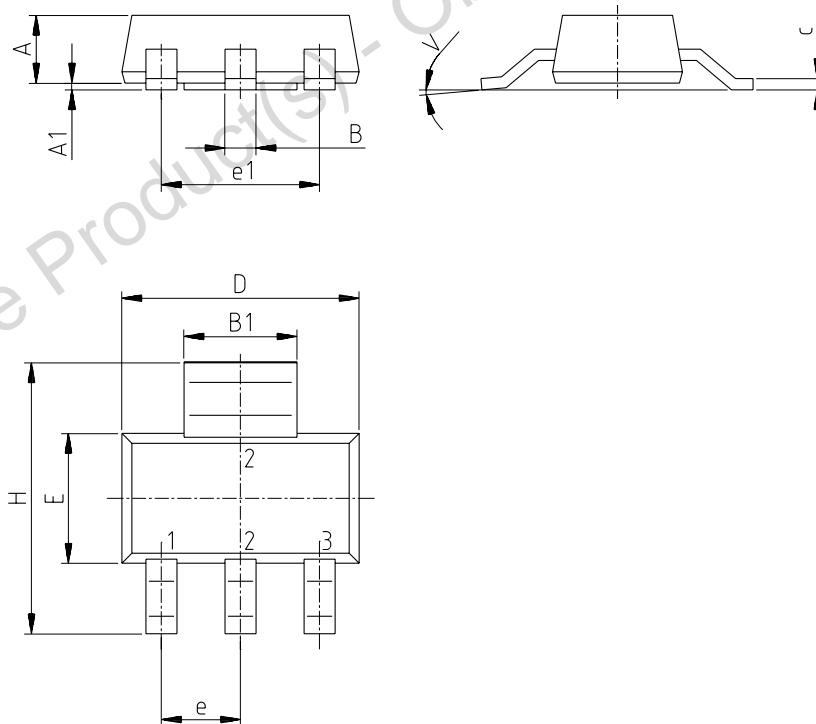

P008B

Obsolete Product(s) - Obsolete Product(s)

Information furnished is believed to be accurate and reliable. However, STMicroelectronics assumes no responsibility for the consequences of use of such information nor for any infringement of patents or other rights of third parties which may result from its use. No license is granted by implication or otherwise under any patent or patent rights of STMicroelectronics. Specification mentioned in this publication are subject to change without notice. This publication supersedes and replaces all information previously supplied. STMicroelectronics products are not authorized for use as critical components in life support devices or systems without express written approval of STMicroelectronics.

The ST logo is a trademark of STMicroelectronics

© 2003 STMicroelectronics – Printed in Italy – All Rights Reserved

STMicroelectronics GROUP OF COMPANIES

Australia - Brazil - Canada - China - Finland - France - Germany - Hong Kong - India - Israel - Italy - Japan - Malaysia - Malta - Morocco - Singapore - Spain - Sweden - Switzerland - United Kingdom - United States.

<http://www.st.com>