

DUAL POWER AMPLIFIER

- SUPPLY VOLTAGE DOWN TO 3 V
- LOW CROSSOVER DISTORSION
- LOW QUIESCENT CURRENT
- BRIDGE OR STEREO CONFIGURATION

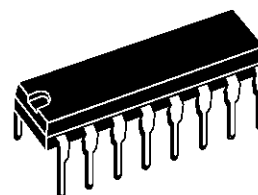

POWERDIP
(Plastic 12+2+2)

ORDERING NUMBER : TDA2822

DESCRIPTION

The TDA2822 is a monolithic integrated circuit in 12+2+2 powerdip, intended for use as dual audio power amplifier in portable radios and TS sets.

TYPICAL APPLICATION CIRCUIT (STEREO)

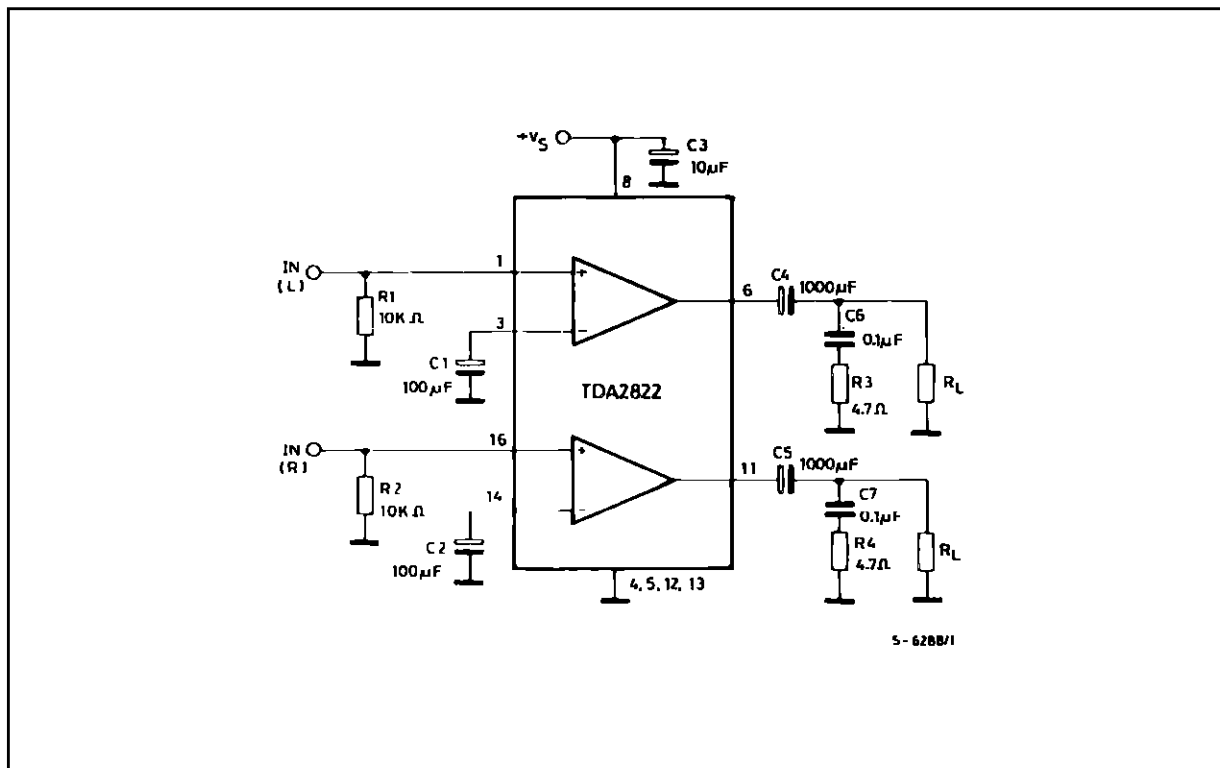

TDA2822

PIN CONNECTION (top view)

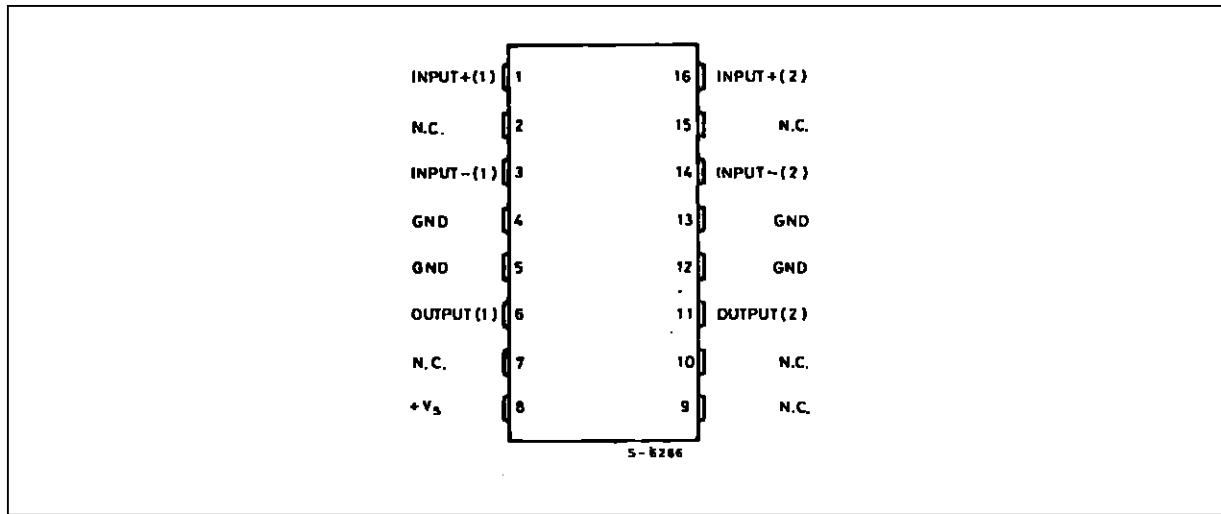

SCHEMATIC DIAGRAM

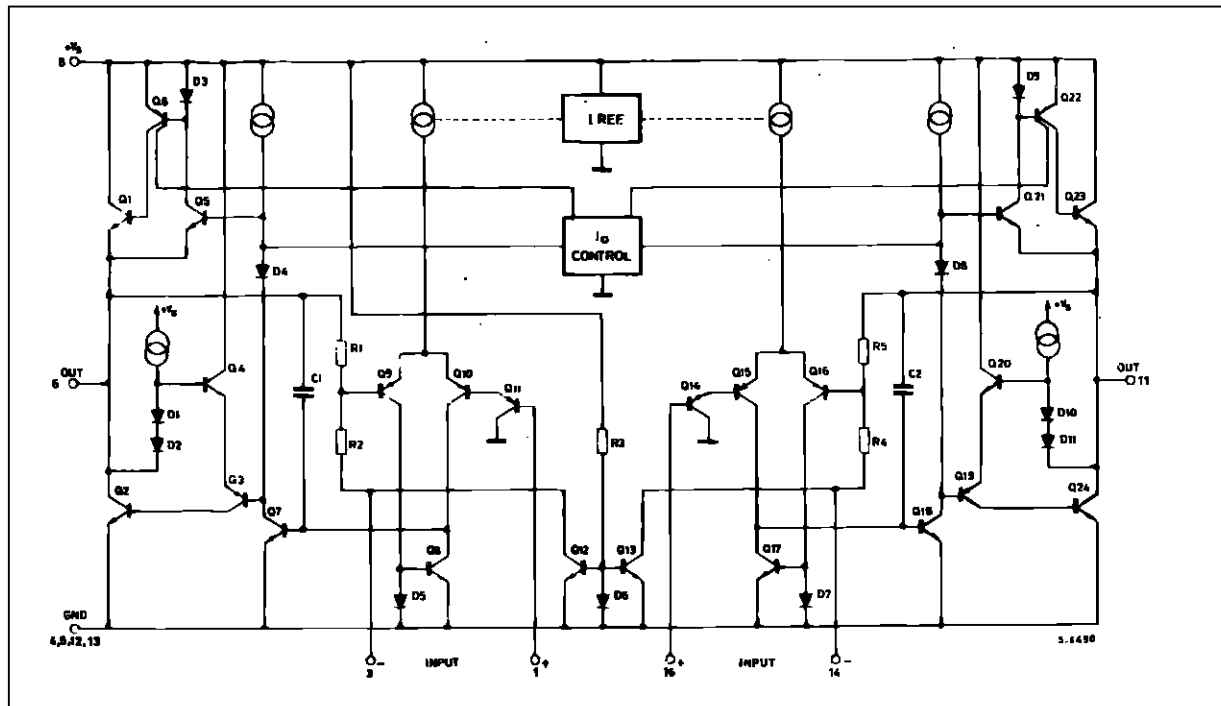

ABSOLUTE MAXIMUM RATINGS

Symbol	Parameter	Value	Unit
V _s	Supply Voltage	15	V
I _o	Output Peak Current	1.5	A
P _{tot}	Total Power Dissipation at T _{amb} = 50 °C at T _{case} = 70 °C	1.25 4	W W
T _{stg} , T _j	Storage and Junction Temperature	- 40 to 150	°C

THERMAL DATA

Symbol	Parameter	Value	Unit
$R_{th\ j-amb}$	Thermal Resistance Junction-ambient	Max 80	$^{\circ}C/W$
$R_{th\ j-case}$	Thermal Resistance Junction-pins	Max 20	$^{\circ}C/W$

ELECTRICAL CHARACTERISTICS ($V_s = 6\text{ V}$, $T_{amb} = 25\text{ }^{\circ}C$, unless otherwise specified)
STEREO (test circuit of fig. 1)

Symbol	Parameter	Test Condition	Min.	Typ.	Max.	Unit
V_s	Supply Voltage		3		15	V
V_c	Quiescent Output Voltage	$V_s = 9\text{ V}$ $V_s = 6\text{ V}$		4 2.7		V V
I_d	Quiescent Drain Current			6	12	mA
I_b	Input Bias Current			100		nA
P_o	Output Power (each channel)	$d = 10\%$ $f = 1\text{ kHz}$ $V_s = 9\text{ V}$ $R_L = 4\ \Omega$ $V_s = 6\text{ V}$ $R_L = 4\ \Omega$ $V_s = 4.5\text{ V}$ $R_L = 4\ \Omega$	1.3 0.45	1.7 0.65 0.32		W W W
G_v	Closed Loop Voltage Gain	$f = 1\text{ kHz}$	36	39	41	dB
R_i	Input Resistance	$f = 1\text{ kHz}$	100			k Ω
e_N	Total Input Noise	$R_s = 10\text{ k}\Omega$ $B = 22\text{ Hz to }22\text{ kHz}$ Curve A		2.5 2		μV μV
SVR	Supply Voltage Rejection	$f = 100\text{ Hz}$	24	30		dB
CS	Channel Separation	$R_g = 10\text{ k}\Omega$ $f = 1\text{ kHz}$		50		dB

BRIDGE (test circuit of fig. 2)

V_s	Supply Voltage		3		15	V
I_d	Quiescent Drain Current	$R_L = \infty$		6	12	mA
V_{os}	Output Offset Voltage	$R_L = 8\ \Omega$		10	60	mV
I_b	Input Bias Current			100		nA
P_o	Output Power	$d = 10\%$ $f = 1\text{ kHz}$ $V_s = 9\text{ V}$ $R_L = 8\ \Omega$ $V_s = 6\text{ V}$ $R_L = 8\ \Omega$ $V_s = 4.5\text{ V}$ $R_L = 4\ \Omega$	2.7 0.9	3.2 1.35 1		W W W
d	Distortion ($f = 1\text{ kHz}$)	$R_L = 8\ \Omega$ $P_o = 0.5\text{ W}$		0.2		%
G_v	Closed Loop Voltage Gain	$f = 1\text{ kHz}$		39		dB
R_i	Input Resistance	$f = 1\text{ kHz}$	100			k Ω
e_N	Total Input Noise	$R_s = 10\text{ k}\Omega$ $B = 22\text{ Hz to }22\text{ kHz}$ Curve A		3 2.5		μV μV
SVR	Supply Voltage Rejection	$f = 100\text{ Hz}$		40		dB

TDA2822

Figure 1 : Test Circuit (stereo).

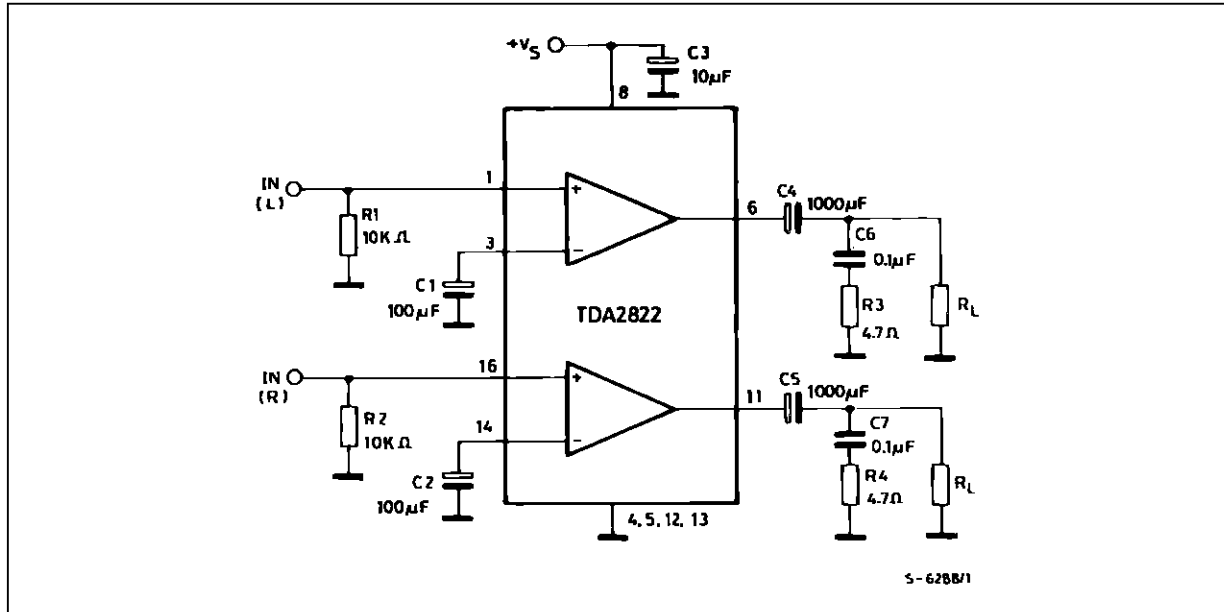

Figure 2 : P.C. Board and Components Layout of the Circuit of Figure 1 (1:1 scale).

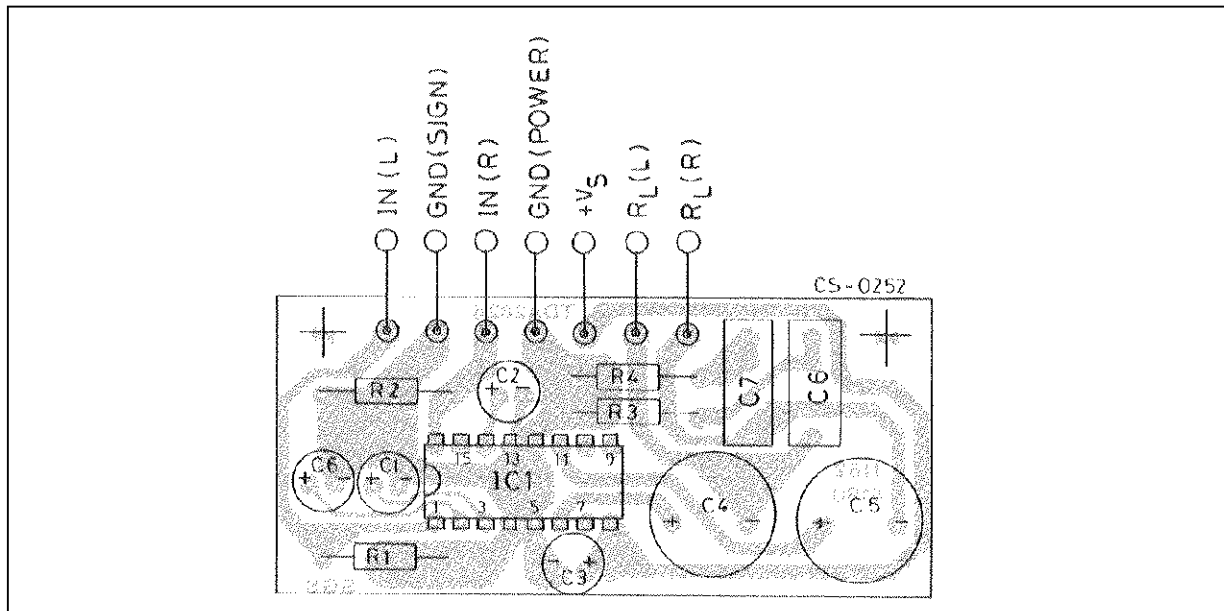

Figure 3 : Test Circuit (bridge).

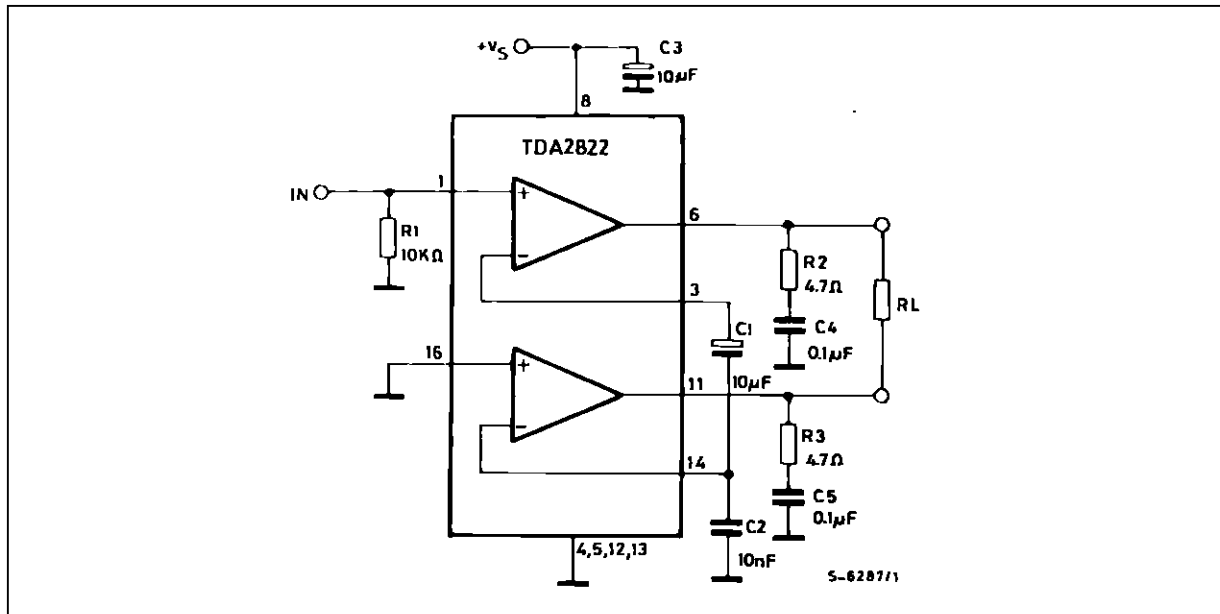

Figure 4 : P.C. Board and Components Layout of the Circuit of Figure 3 (1:1 scale).

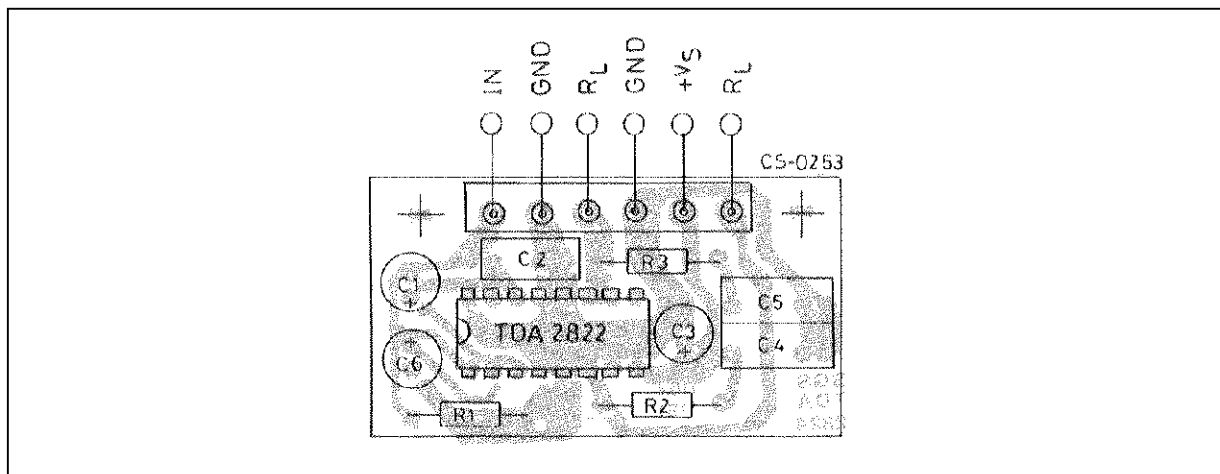

Figure 5 : Output Power vs. Supply Voltage (Stereo).

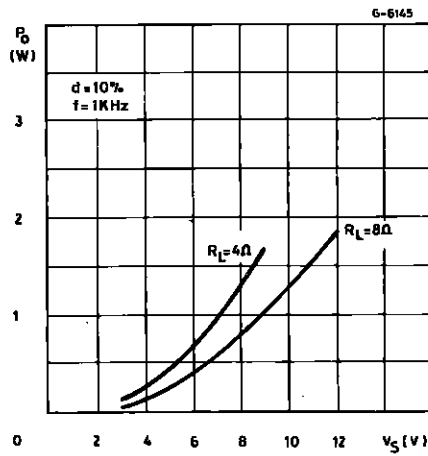

Figure 6 : Output Power vs. Supply Voltage (Bridge).

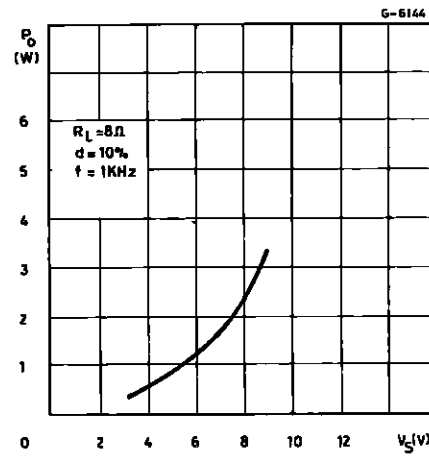

Figure 7 : Distorsion vs. Output Power (Bridge).

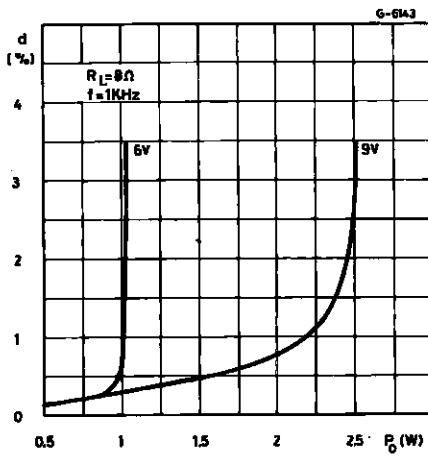

Figure 8 : Distorsion vs. Output Power (Bridge).

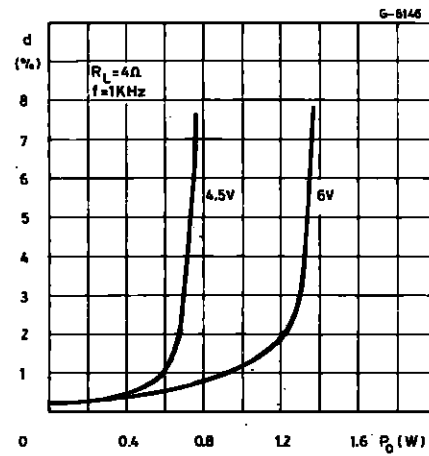

Figure 9 : Supply Voltage Rejection vs. Frequency.

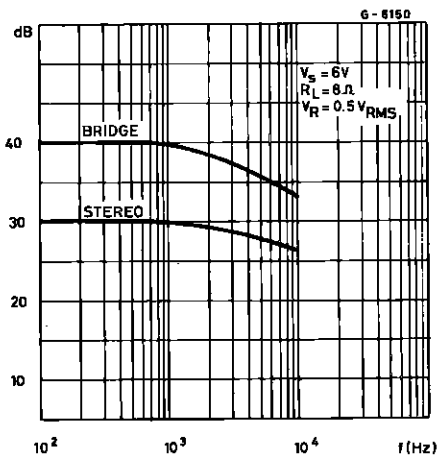

Figure 10 : Quiescent Current vs. Supply Voltage.

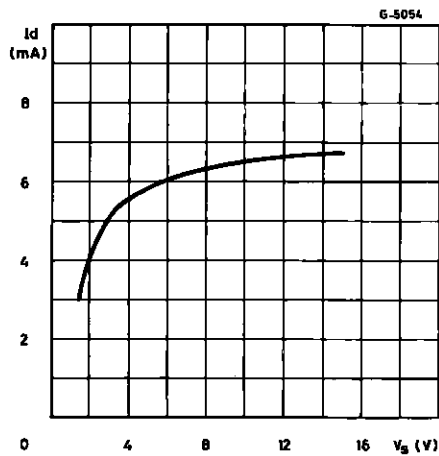

Figure 11 : Total Power Dissipation vs. Output Power (Stereo).

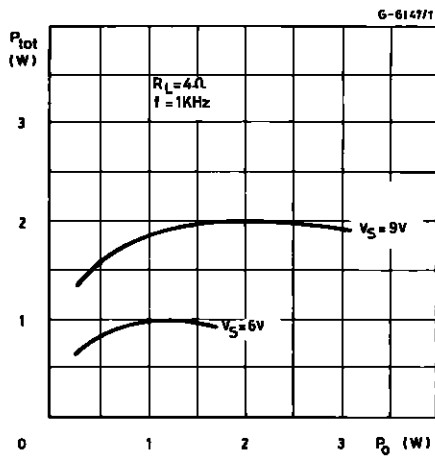

Figure 12 : Total Power Dissipation vs. Output Power (Bridge).

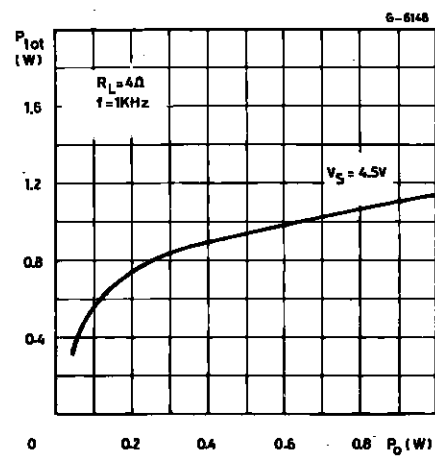

Figure 13 : Total Power Dissipation vs. Output Power (Bridge).

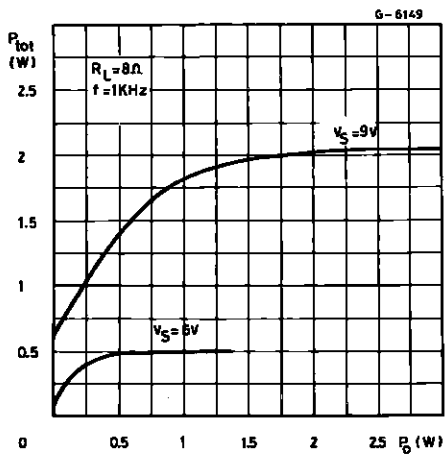

Figure 6 : Maximum Dissipable Power and Junction to Ambient Thermal Resistance vs. Side "d".

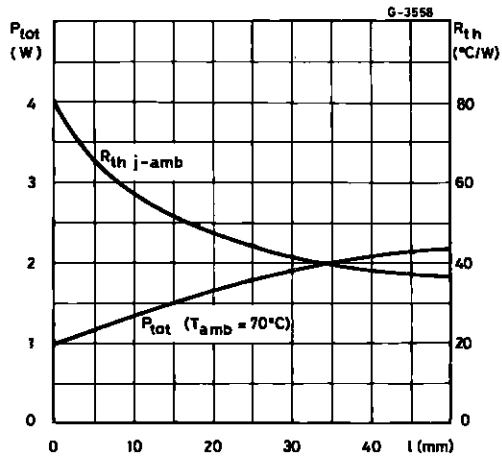
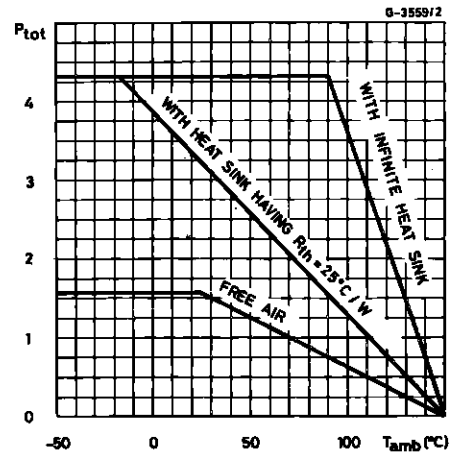

Figure 7 : Maximum Allowable Power Dissipation vs. Ambient Temperature.



TDA2822

POWERDIP 16 PACKAGE MECHANICAL DATA

DIM.	mm			inch		
	MIN.	TYP.	MAX.	MIN.	TYP.	MAX.
a1	0.51			0.020		
B	0.85		1.40	0.033		0.055
b		0.50			0.020	
b1	0.38		0.50	0.015		0.020
D			20.0			0.787
E		8.80			0.346	
e		2.54			0.100	
e3		17.78			0.700	
F			7.10			0.280
I			5.10			0.201
L		3.30			0.130	
Z			1.27			0.050

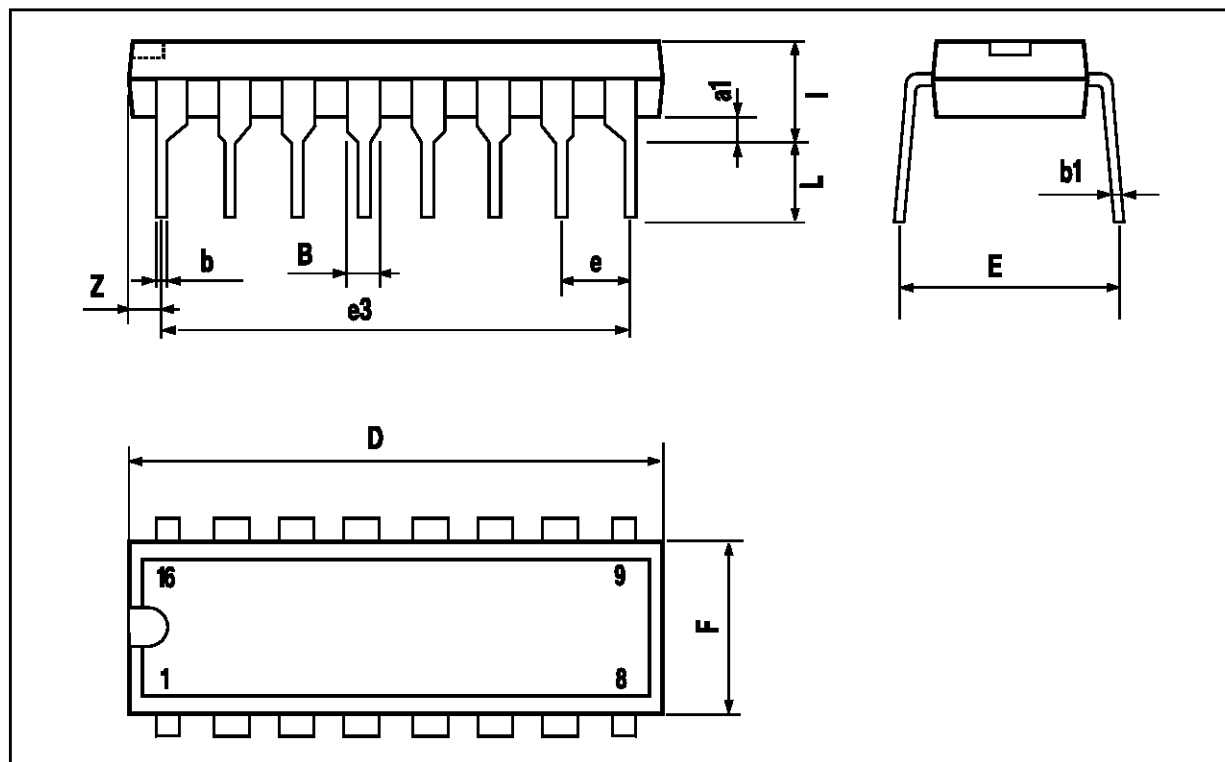

Information furnished is believed to be accurate and reliable. However, SGS-THOMSON Microelectronics assumes no responsibility for the consequences of use of such information nor for any infringement of patents or other rights of third parties which may result from its use. No license is granted by implication or otherwise under any patent or patent rights of SGS-THOMSON Microelectronics. Specifications mentioned in this publication are subject to change without notice. This publication supersedes and replaces all information previously supplied. SGS-THOMSON Microelectronics products are not authorized for use as critical components in life support devices or systems without express written approval of SGS-THOMSON Microelectronics.

© 1995 SGS-THOMSON Microelectronics - All Rights Reserved

SGS-THOMSON Microelectronics GROUP OF COMPANIES

Australia - Brazil - France - Germany - Hong Kong - Italy - Japan - Korea - Malaysia - Malta - Morocco - The Netherlands - Singapore - Spain - Sweden - Switzerland - Taiwan - Thailand - United Kingdom - U.S.A.