





**Table 4. Electrical Characteristics** (Refer to the test circuit  $V_S = \pm 10V$ ;  $R_S = 50\Omega$ ;  $G_V = 30dB$ ,  $f = 1KHz$ ;  $T_{amb} = 25^\circ C$ , unless otherwise specified)

Symbol	Parameter	Test Condition	Min.	Typ.	Max.	Unit
$V_S$	Supply Voltage Range	$R_L = 8\Omega$	$\pm 5$		$\pm 18$	V
		$R_L = 4\Omega$ ;	$\pm 5$		$\pm 13.5$	V
$I_q$	Total Quiescent Current			50	90	mA
$V_{OS}$	Input Offset Voltage		-25		+25	mV
$I_b$	Output Bias Current			500		nA
$P_O$	Output Power	THD = 10%; $R_L = 8\Omega$ ; $V_S = \pm 8.5V$ ; $R_L = 4\Omega$ ;		6 6		W W
		THD = 1%; $R_L = 8\Omega$ ; $V_S = \pm 8.5V$ ; $R_L = 4\Omega$ ;		5 5		W W
THD	Total Harmonic Distortion	$R_L = 8\Omega$ ; $P_O = 1W$ ; $f = 1KHz$ ;		0.03		%
		$R_L = 8\Omega$ ; $V_S = \pm 10V$ ; $P_O = 0.1$ to $3W$ ; $f = 100Hz$ to $15KHz$ ;		0.2	0.5	%
		$R_L = 4\Omega$ ; $P_O = 1W$ ; $f = 1KHz$ ;		0.02		%
		$R_L = 4\Omega$ ; $V_S = \pm 8.5V$ ; $P_O = 0.1$ to $2W$ ; $f = 100Hz$ to $15KHz$ ;		0.2	1	%
$C_T$	Cross Talk	$f = 1KHz$ ; $f = 10KHz$ ;	50	70 60		dB dB
SR	Slew Rate		6.5	10		V/ $\mu s$
$G_{OL}$	Open Loop Voltage Gain			80		dB
$e_N$	Total Output Noise	A Curve $f = 20Hz$ to $22KHz$		3 4	8	$\mu V$ $\mu V$
$R_i$	Input Resistance		15	20		K $\Omega$
SVR	Supply Voltage Rejection (each channel)	$f = 100Hz$ ; $V_R = 0.5V$		60		dB
$T_j$	Thermal Shut-down Junction Temperature			145		$^\circ C$
<b>MUTE &amp; INPUT SELECTION FUNCTIONS</b>						
$V_{MUTE}$	Mute /Play threshold		-7	-6	-5	V
$A_{MUTE}$	Mute Attenuation		60	70		dB
<b>STAND-BY FUNCTIONS [ref: +V<sub>S</sub>] (only for Split Supply)</b>						
$V_{ST-BY}$	Stand-by Mute threshold		-3.5	-2.5	-0.5	V
$A_{ST-BY}$	Stand-by Attenuation			110		dB
$I_{qST-BY}$	Quiescent Current @ Stand-by			3	6	mA

**Table 5. Electrical Characteristics in Single Supply**

(by correlation with test conditions in split supply)

Symbol	Parameter	Test Condition	Min.	Typ.	Max.	Unit
V <sub>S</sub>	Supply Range	R <sub>L</sub> = 8Ω	10		36	V
		R <sub>L</sub> = 4Ω	10		27	V
I <sub>q</sub>	Total Quiescent Current			50	90	mA
I <sub>b</sub>	Non Inverting Input Bias Current			500		nA
P <sub>O</sub>	Output Power	THD = 10% R <sub>L</sub> = 8Ω V <sub>S</sub> = 22V; R <sub>L</sub> = 4Ω	8	10 7.5		W W
		THD = 1% R <sub>L</sub> = 8Ω V <sub>S</sub> = 22V; R <sub>L</sub> = 4Ω	6	7.5 6		W W
THD	Total Harmonic Distortion	R <sub>L</sub> = 8Ω ; P <sub>O</sub> = 1W; f = 1KHz		0.03		%
		R <sub>L</sub> = 8Ω ; P <sub>O</sub> = 0.1 to 5W; V <sub>S</sub> = 26V; f = 100Hz to 15KHz		0.2	0.5	%
		R <sub>L</sub> = 4Ω ; P <sub>O</sub> = 1W; f = 1KHz		0.02		%
		R <sub>L</sub> = 4Ω ; V <sub>S</sub> = 20V; P <sub>O</sub> = 0.1 to 4W; f = 100Hz to 15KHz		0.2	1	%
C <sub>T</sub>	Cross Talk	f = 1KHz		70		dB
		f = 10KHz	50	60		dB
SR	Slew Rate		6.5	10		V/μs
G <sub>OL</sub>	Open Loop Voltage Gain			80		dB
e <sub>N</sub>	Total Input Noise	A Curve f = 20Hz to 22KHz		3 4	8	μV μV
				15	20	
SVR	Supply Voltage Rejection (each channel)	f <sub>r</sub> = 100Hz; V <sub>r</sub> = 0.5V		60		dB
T <sub>j</sub>	Thermal Shut-down Junction Temperature			145		°C
<b>MUTE FUNCTION [ref: +V<sub>S</sub>]</b>						
V <sub>T_MUTE</sub>	Mute / Play Threshold		-7	-6	-5	V
A <sub>M</sub>	Mute Attenuation		60	70		dB

### 3 MUTE STAND-BY FUNCTION

The pin 5 (MUTE/STAND-BY) controls the amplifier status by two different thresholds, referred to  $+V_S$ .

- When  $V_{pin5}$  higher than  $+V_S - 2.5V$  the amplifier is in Stand-by mode and the final stage generators are off.
- When  $V_{pin5}$  between  $+V_S - 2.5V$  and  $V_S - 6V$  the final stage generators are switched on and the amplifier is in mute mode.
- When  $V_{pin5}$  lower than  $+V_S - 6V$  the amplifier is play mode.

Figure 5.

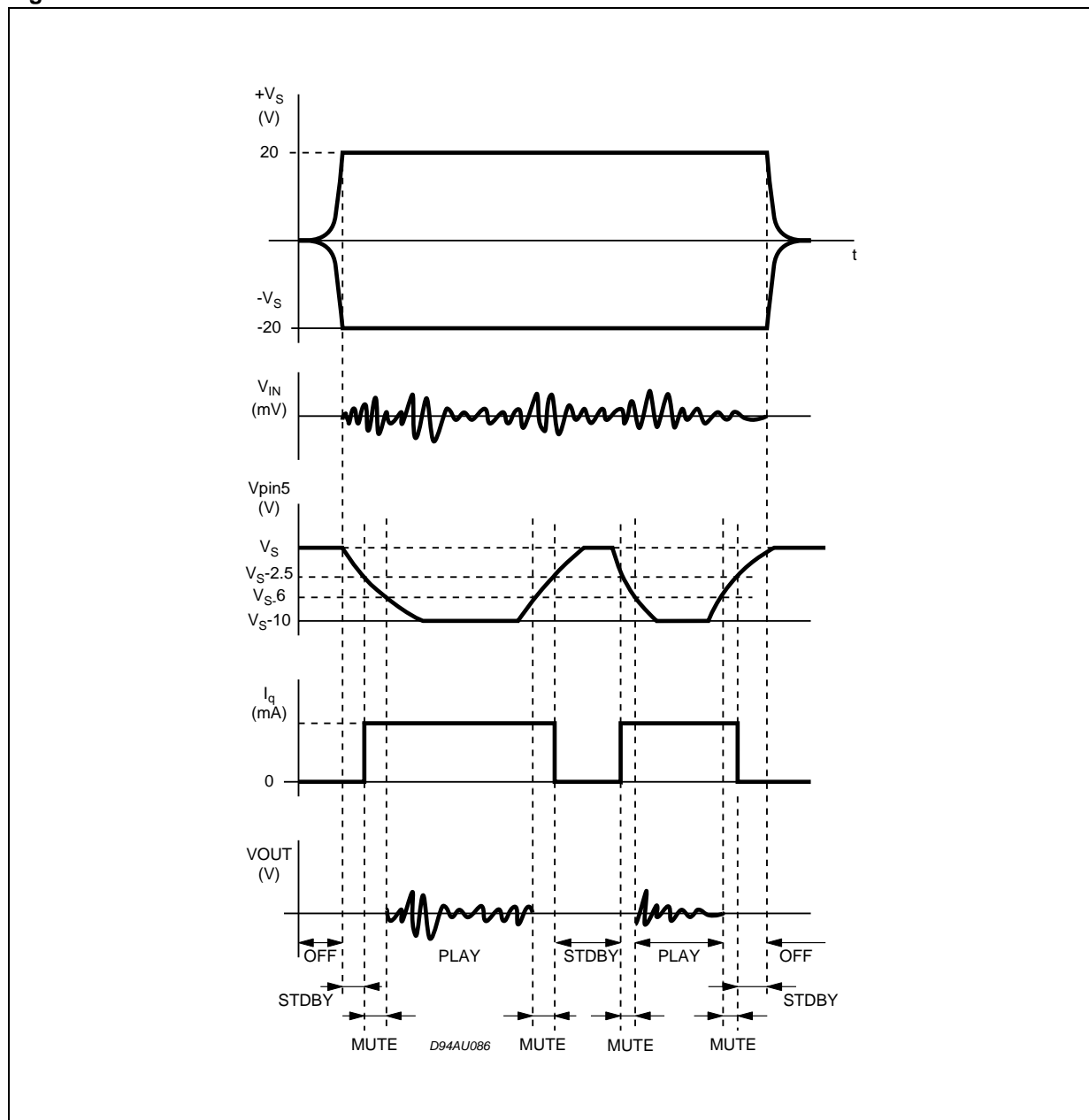
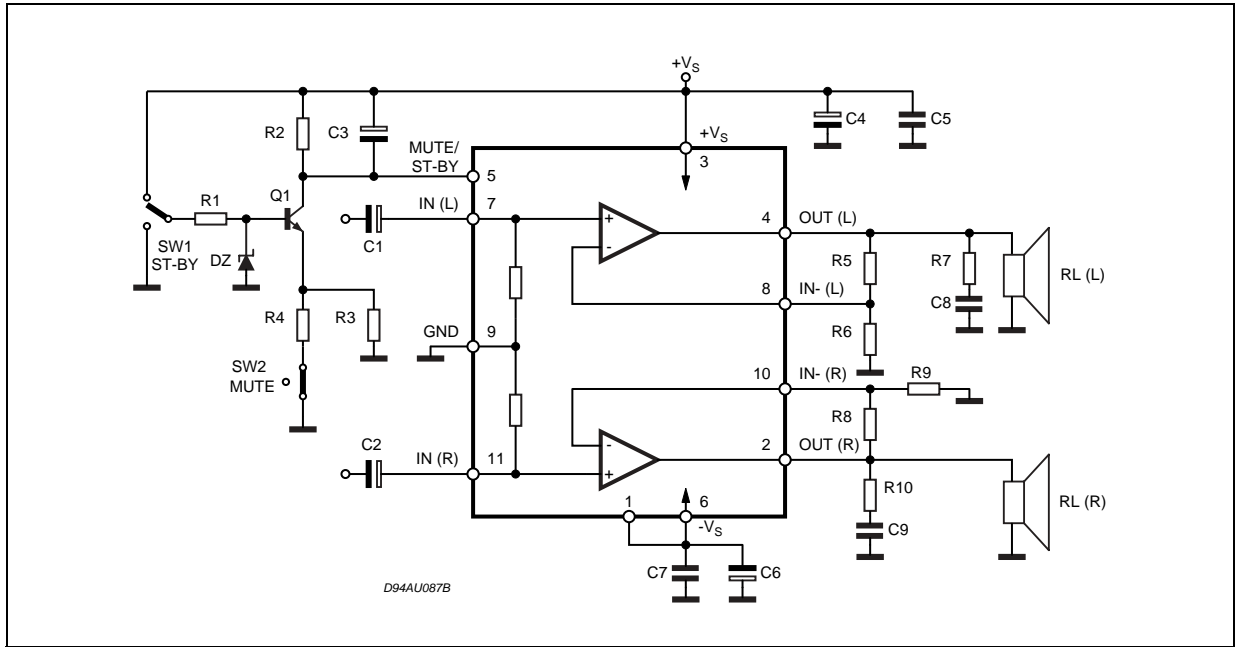

Figure 6. Test and Application Circuit (Stereo Configuration)



## 4 APPLICATION SUGGESTIONS

(Demo Board Schematic)

The recommended values of the external components are those shown the demoboard schematic different values can be used, the following table can help the designer.

Table 6.

COMPONENT	SUGGESTION VALUE	PURPOSE	LARGER THAN RECOMMENDED VALUE	SMALLER THAN RECOMMENDED VALUE
R1	10KΩ	Mute Circuit	Increase of Dz Biasing Current	
R2	15KΩ	Mute Circuit	V <sub>pin #5</sub> Shifted Downward	V <sub>pin #5</sub> Shifted Upward
R3	18KΩ	Mute Circuit	V <sub>pin #5</sub> Shifted Upward	V <sub>pin #5</sub> Shifted Downward
R4	15KΩ	Mute Circuit	V <sub>pin #5</sub> Shifted Upward	V <sub>pin #5</sub> Shifted Downward
R5, R8	18KΩ	Closed Loop Gain Setting (*)	Increase of Gain	
R6, R9	560KΩ		Decrease of Gain	
R7, R10	4.7Ω	Frequency Stability	Danger of Oscillations	Danger of Oscillations
C1, C2	1μF	Input DC Decoupling		Higher low frequency cutoff
C3	1μF	St-By/Mute Time Constant	Larger On/Off Time	Smaller On/Off Time
C4, C6	1000μF	Supply Voltage Bypass		Danger of Oscillations
C5, C7	0.1μF	Supply Voltage Bypass		Danger of Oscillations
C8, C9	0.1μF	Frequency Stability		
Dz	5.1V	Mute Circuit		

(\*) Closed loop gain has to be ≥25dB

Figure 7. Multiwatt11V Mechanical Data &amp; Package Dimensions

DIM.	mm			inch		
	MIN.	TYP.	MAX.	MIN.	TYP.	MAX.
A			5			0.197
B			2.65			0.104
C			1.6			0.063
D		1			0.039	
E	0.49		0.55	0.019		0.022
F	0.88		0.95	0.035		0.037
G	1.45	1.7	1.95	0.057	0.067	0.077
G1	16.75	17	17.25	0.659	0.669	0.679
H1	19.6			0.772		
H2			20.2			0.795
L	21.9	22.2	22.5	0.862	0.874	0.886
L1	21.7	22.1	22.5	0.854	0.87	0.886
L2	17.4		18.1	0.685		0.713
L3	17.25	17.5	17.75	0.679	0.689	0.699
L4	10.3	10.7	10.9	0.406	0.421	0.429
L7	2.65		2.9	0.104		0.114
M	4.25	4.55	4.85	0.167	0.179	0.191
M1	4.73	5.08	5.43	0.186	0.200	0.214
S	1.9		2.6	0.075		0.102
S1	1.9		2.6	0.075		0.102
Dia1	3.65		3.85	0.144		0.152

### OUTLINE AND MECHANICAL DATA

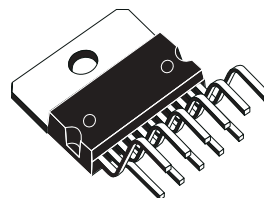

### Multiwatt11 (Vertical)

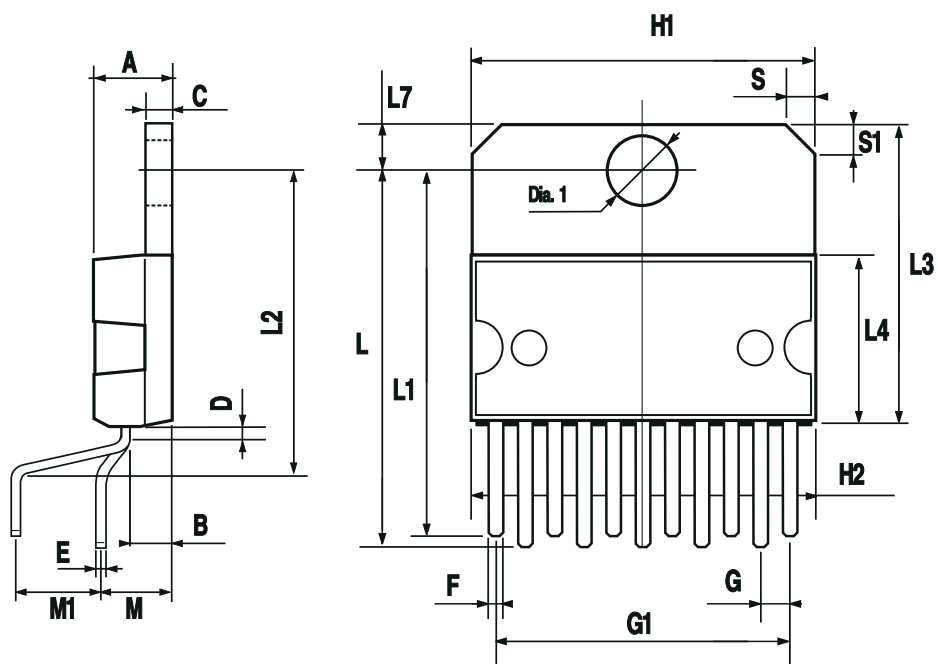

0016035 H

**Table 7. Revision History**

<b>Date</b>	<b>Revision</b>	<b>Description of Changes</b>
September 2003	4	First Issue in EDOCS DMS
August 2004	5	Stylesheet update. Change fig. 4

Information furnished is believed to be accurate and reliable. However, STMicroelectronics assumes no responsibility for the consequences of use of such information nor for any infringement of patents or other rights of third parties which may result from its use. No license is granted by implication or otherwise under any patent or patent rights of STMicroelectronics. Specifications mentioned in this publication are subject to change without notice. This publication supersedes and replaces all information previously supplied. STMicroelectronics products are not authorized for use as critical components in life support devices or systems without express written approval of STMicroelectronics.

The ST logo is a registered trademark of STMicroelectronics.  
All other names are the property of their respective owners

© 2004 STMicroelectronics - All rights reserved

STMicroelectronics group of companies

Australia - Belgium - Brazil - Canada - China - Czech Republic - Finland - France - Germany - Hong Kong - India - Israel - Italy - Japan -  
Malaysia - Malta - Morocco - Singapore - Spain - Sweden - Switzerland - United Kingdom - United States of America

[www.st.com](http://www.st.com)