

## Precision Dual Operational Amplifier

- Low input offset voltage: 500 $\mu$ V max.
- Low power consumption
- Short circuit protection
- Low distortion, low noise
- High gain-bandwidth product
- High channel separation
- ESD protection 2kV
- Macromodel included in this specification

### Description

The TS514 is a high performance quad operational amplifier with frequency and phase compensation built into the chip. The internal phase compensation allows stable operation as voltage follower in spite of its high gain-bandwidth products.

The circuit presents very stable electrical characteristics over the entire supply voltage range, and is particularly intended for professional and telecom applications (active filter, etc).

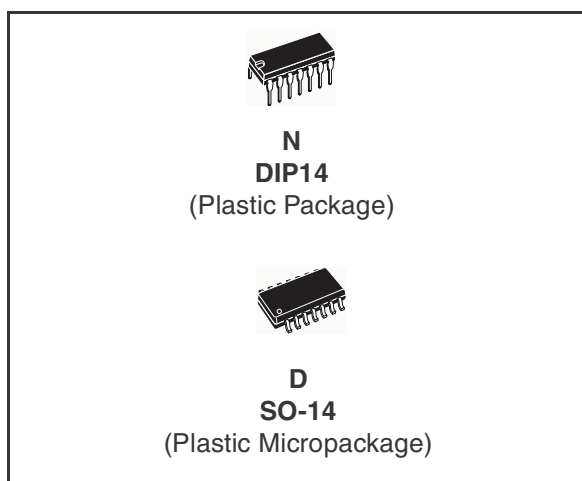

### Pin Connections (top view)

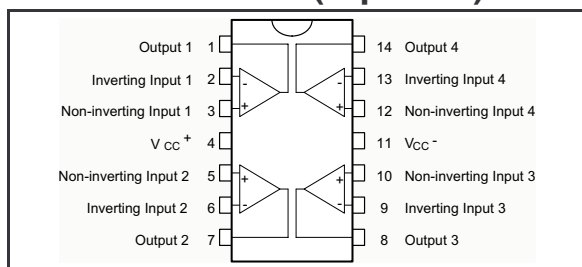

### Order Codes

| Part Number          | Temperature Range | Package                       | Packaging           | Marking |
|----------------------|-------------------|-------------------------------|---------------------|---------|
| TS514IN/AIN          | -40, + 125°C      | DIP8                          | Tube                |         |
| TS514ID/IDT/AID/AIDT |                   | SO-8                          |                     |         |
| TS514IYD/IYDT        |                   | SO14 (automotive grade level) | Tube or Tape & Reel |         |
| TS514AIYD/AIYDT      |                   |                               |                     |         |

# 1 Absolute Maximum Ratings

**Table 1. Key parameters and their absolute maximum ratings**

| Symbol     | Parameter  | Value                          | Unit |
|------------|--|--------------------------------|------|
| $V_{CC}$   | Supply Voltage   | $\pm 18$                       | V    |
| $V_i$      | Input Voltage<br>Positive<br>Negative                              | $\pm V_{CC}$<br>$- V_{CC} 0.5$ |      |
| $V_{id}$   | Differential Input Voltage   | $\pm(V_{CC} - 1)$              |      |
| $T_{oper}$ | Operating Free-Air Temperature Range                               | -40 to +125                    | °C   |
| $P_{tot}$  | Power Dissipation at $T_{amb} = 70^{\circ}\text{C}$ <sup>(1)</sup> | 400                            | mW   |
| $T_{stg}$  | Storage Temperature Range  | -65 to +150                    | °C   |

1. Power dissipation must be considered to ensure maximum junction temperature ( $T_j$ ) is not exceeded.

## 2 Schematic Diagram (1/4 TS514)

Figure 1. Typical application schematic

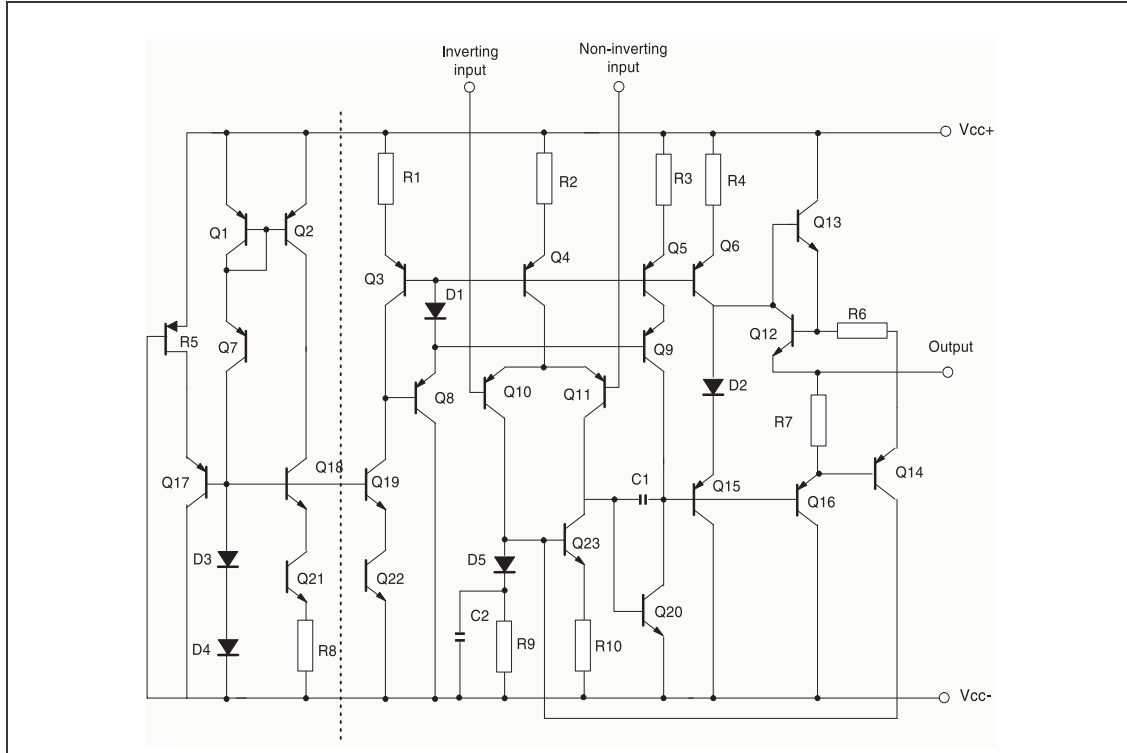

### 3 ELECTRICAL CHARACTERISTICS

**Table 2.**  $V_{CC} = \pm 15V$ ,  $T_{amb} = 25^{\circ}C$  (unless otherwise specified)

| Symbol          | Parameter   | Min.     | Typ.          | Max.                   | Unit                   |
|-----------------|---|----------|---------------|------------------------|------------------------|
| $I_{CC}$        | Supply Current  |          | 1.4           | 2.4                    | mA                     |
| $I_{ib}$        | Input Bias Current<br>$T_{min} \leq T_{op} \leq T_{max}$  |          | 50            | 150<br>300             | nA                     |
| $R_i$           | Input Resistance, $f = 1kHz$  |          | 1             |                        | M $\Omega$             |
| $V_{io}$        | Input Offset Voltage<br>TS514<br>TS514A<br>$T_{min} \leq T_{op} \leq T_{max}$<br>TS514<br>TS514A        |          | 0.5           | 2.5<br>0.5<br>4<br>1.5 | mV                     |
| $\Delta V_{io}$ | Input Offset Voltage Drift<br>$T_{min} \leq T_{op} \leq T_{max}$  |          | 5             |                        | $\mu V/^{\circ}C$      |
| $I_{io}$        | Input Offset Current<br>$T_{min} \leq T_{op} \leq T_{max}$  |          | 5             | 20<br>40               | nA                     |
| $\Delta I_{io}$ | Input Offset Current Drift<br>$T_{min} \leq T_{op} \leq T_{max}$  |          | 0.08          |                        | $\frac{nA}{^{\circ}C}$ |
| $I_{os}$        | Output Short Circuit Current  |          | 23            |                        | mA                     |
| $A_{vd}$        | Large Signal Voltage Gain<br>$R_L = 2k\Omega$<br>$V_{CC} = \pm 15V$<br>$V_{CC} = \pm 4V$                | 90       | 100<br>95     |                        | dB                     |
| GBP             | Gain-bandwidth Product, $f = 100kHz$  | 1.8      | 3             |                        | MHz                    |
| $e_n$           | Equivalent Input Noise Voltage, $f = 1kHz$<br>$R_s = 50\Omega$<br>$R_s = 1k\Omega$<br>$R_s = 10k\Omega$ |          | 8<br>10<br>18 | 15                     | $\frac{nV}{\sqrt{Hz}}$ |
| THD             | Total Harmonic Distortion<br>$A_v = 20dB$ , $R_L = 2k\Omega$<br>$V_o = 2V_{pp}$ , $f = 1kHz$            |          | 0.03          | 0.1                    | %                      |
| $\pm V_{opp}$   | Output Voltage Swing<br>$R_L = 2k\Omega$<br>$V_{CC} = \pm 15V$<br>$V_{CC} = \pm 4V$                     | $\pm 13$ | $\pm 3$       |                        | V                      |
| $V_{opp}$       | Large Signal Voltage Swing<br>$R_L = 10k\Omega$<br>$f = 10kHz$  |          | 28            |                        | $V_{pp}$               |
| SR              | Slew Rate<br>Unity Gain, $R_L = 2k\Omega$   | 0.8      | 1.5           |                        | V/ $\mu s$             |
| CMR             | Common Mode Rejection Ratio<br>$V_{ic} = 10V$   | 90       |               |                        | dB                     |

**Table 2.**  $V_{CC} = \pm 15V$ ,  $T_{amb} = 25^{\circ}C$  (unless otherwise specified)

| Symbol          | Parameter   | Min. | Typ. | Max. | Unit |
|-----------------|---|------|------|------|------|
| SVR             | Supply Voltage Rejection Ratio<br>$dV_{ic} = 10V$ , $f = 100Hz$ | 90   |      |      | dB   |
| $V_{o1}/V_{o2}$ | Channel Separation - $f = 1kHz$                                 |      | 120  |      | dB   |

**Table 3.**  $V_{CC} = \pm 15V$ ,  $T_{amb} = 25^{\circ}C$  (unless otherwise specified)

| Symbol          | Conditions                       | Value         | Unit      |
|-----------------|----------------------------------|---------------|-----------|
| $V_{io}$        |                                  | 0             | mV        |
| $A_{vd}$        | $R_L = 2k\Omega$                 | 94            | V/mV      |
| $I_{CC}$        | No load, per operator            | 325           | $\mu A$   |
| $V_{icm}$       |                                  | -13.5 to 13.5 | V         |
| $V_{OH}$        | $R_L = 2k\Omega$                 | +13           | V         |
| $V_{OL}$        | $R_L = 2k\Omega$                 | -13           | V         |
| $I_{sink}$      | $V_o = 0V$                       | 24            | mA        |
| $I_{source}$    | $V_o = 0V$                       | 24            | mA        |
| GBP             | $R_L = 2k\Omega$ , $C_L = 100pF$ | 3             | MHz       |
| SR              | $R_L = 2k\Omega$ , $C_L = 100pF$ | 1.4           | $V/\mu s$ |
| $\varnothing m$ | $R_L = 2k\Omega$ , $C_L = 100pF$ | 55            | Degrees   |

## 4 Macromodels

*Note: Note: Please consider following remarks before using this macromodel:*

*All models are a trade-off between accuracy and complexity (i.e. simulation time).*

*Macromodels are not a substitute to breadboarding; rather, they confirm the validity of a design approach and help to select surrounding component values.*

*A macromodel emulates the NOMINAL performance of a TYPICAL device within SPECIFIED OPERATING CONDITIONS (i.e. temperature, supply voltage, etc.). Thus the macromodel is often not as exhaustive as the datasheet, its goal is to illustrate the main parameters of the product.*

*Data issued from macromodels used outside of its specified conditions (Vcc, Temperature, etc) or even worse: outside of the device operating conditions (Vcc, Vicm, etc) are not reliable in any way.*

```
** Standard Linear Ics Macromodels, 1993.
** CONNECTIONS :
* 1 INVERTING INPUT
* 2 NON-INVERTING INPUT
* 3 OUTPUT
* 4 POSITIVE POWER SUPPLY
* 5 NEGATIVE POWER SUPPLY

.SUBCKT TS514 1 3 2 4 5 (analog)
*****
.MODEL MDTH D IS=1E-8 KF=6.647807E-16 CJO=10F
* INPUT STAGE
CIP 2 5 1.000000E-12
CIN 1 5 1.000000E-12
EIP 10 5 2 5 1
EIN 16 5 1 5 1
RIP 10 11 1.300000E+01
RIN 15 16 1.300000E+01
RIS 11 15 6.437882E+01
DIP 11 12 MDTH 400E-12
DIN 15 14 MDTH 400E-12
VOFP 12 13 DC 0
VOFN 13 14 DC 0
IPOL 13 5 2.000000E-05
CPS 11 15 9.75E-10
DINN 17 13 MDTH 400E-12
VIN 17 5 0.000000e+00
DINR 15 18 MDTH 400E-12
VIP 4 18 1.500000E+00
FCP 4 5 VOFP 1.525000E+01
FCN 5 4 VOFN 1.525000E+01
FIBP 2 5 VOFN 5.000000E-03
FIBN 5 1 VOFP 5.000000E-03
* AMPLIFYING STAGE
FIP 5 19 VOFP 1.125000E+03
```

```
FIN 5 19 VOFN 1.125000E+03
RG1 19 5 6.512062E+05
RG2 19 4 6.512062E+05
CC 19 29 1.500000E-08
HZTP 30 29 VOFN 8.944787E+02
HZTN 5 30 VOFN 8.944787E+02
DOPM 19 22 MDTH 400E-12
DONM 21 19 MDTH 400E-12
HOPM 22 28 VOUT 6.521739E+03
VIPM 28 4 1.500000E+02
HONM 21 27 VOUT 6.521739E+03
VINM 5 27 1.500000E+02
GCOMP 5 4 4 5 7.485029E-04
RPM1 5 80 1E+09
RPM2 4 80 1E+09
GAVPH 5 82 19 80 2.99E-03
RAVPHGH 82 4 668
RAVPHGB 82 5 668
RAVPHDH 82 83 1000
RAVPHDB 82 84 1000
CAVPHH 4 83 0.352E-09
CAVPHB 5 84 0.352E-09
EOUT 26 23 82 5 1
VOUT 23 5 0
ROUT 26 3 150
COUT 3 5 1.000000E-12
DOP 19 25 MDTH 400E-12
VOP 4 25 1.785252E+00
DON 24 19 MDTH 400E-12
VON 24 5 1.785252E+00
.ENDS
```

## 5 Package Mechanical Data

In order to meet environmental requirements, ST offers these devices in ECOPACK® packages. These packages have a Lead-free second level interconnect. The category of second level interconnect is marked on the package and on the inner box label, in compliance with JEDEC Standard JESD97. The maximum ratings related to soldering conditions are also marked on the inner box label. ECOPACK is an ST trademark. ECOPACK specifications are available at: [www.st.com](http://www.st.com).

### 5.1 DIP14 Package

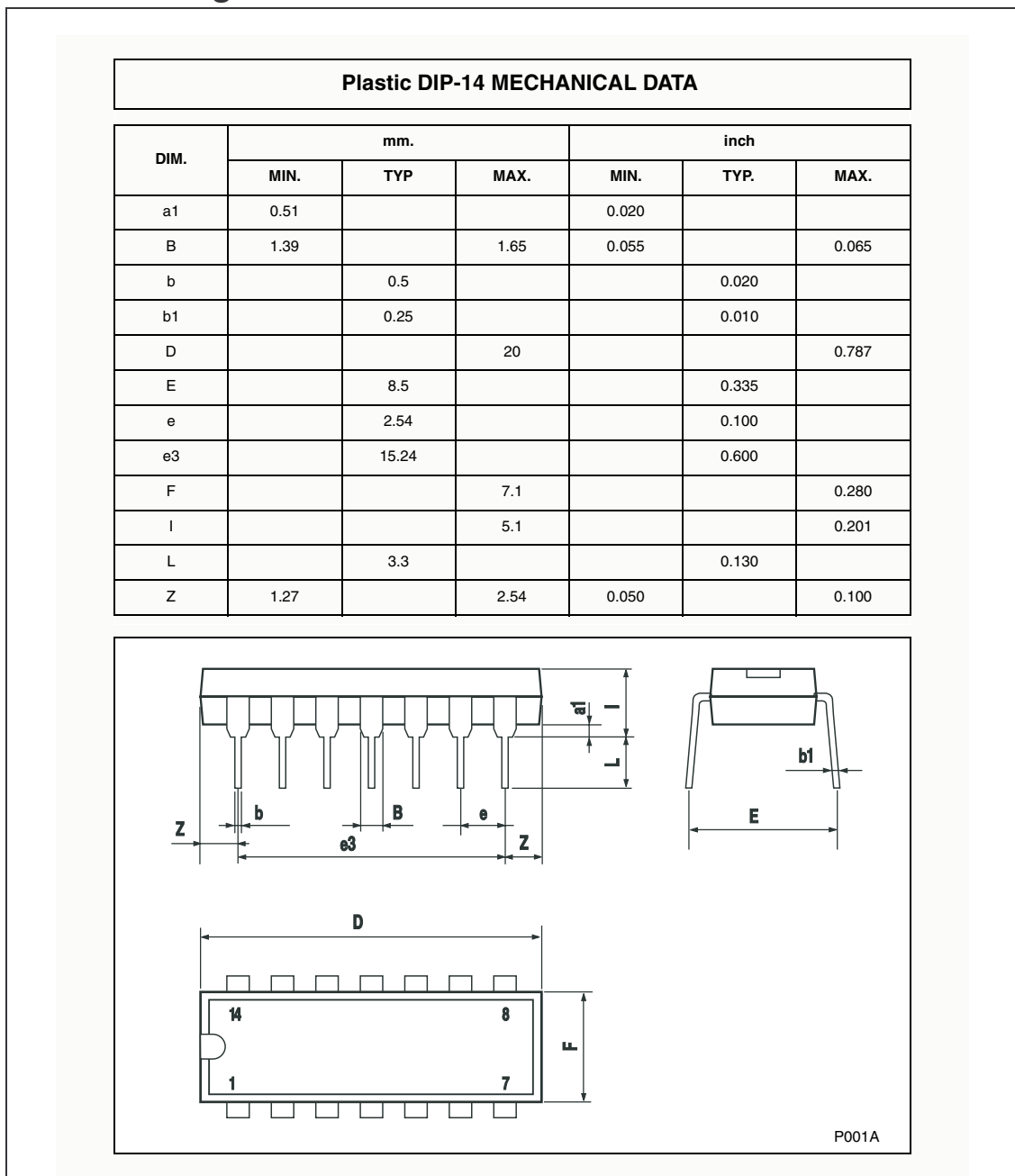

5.2 SO-14 Package

SO-14 MECHANICAL DATA

| DIM. | mm.        |      |      | inch  |       |       |
|------|------------|------|------|-------|-------|-------|
|      | MIN.       | TYP  | MAX. | MIN.  | TYP.  | MAX.  |
| A    |            |      | 1.75 |       |       | 0.068 |
| a1   | 0.1        |      | 0.2  | 0.003 |       | 0.007 |
| a2   |            |      | 1.65 |       |       | 0.064 |
| b    | 0.35       |      | 0.46 | 0.013 |       | 0.018 |
| b1   | 0.19       |      | 0.25 | 0.007 |       | 0.010 |
| C    |            | 0.5  |      |       | 0.019 |       |
| c1   | 45° (typ.) |      |      |       |       |       |
| D    | 8.55       |      | 8.75 | 0.336 |       | 0.344 |
| E    | 5.8        |      | 6.2  | 0.228 |       | 0.244 |
| e    |            | 1.27 |      |       | 0.050 |       |
| e3   |            | 7.62 |      |       | 0.300 |       |
| F    | 3.8        |      | 4.0  | 0.149 |       | 0.157 |
| G    | 4.6        |      | 5.3  | 0.181 |       | 0.208 |
| L    | 0.5        |      | 1.27 | 0.019 |       | 0.050 |
| M    |            |      | 0.68 |       |       | 0.026 |
| S    | 8° (max.)  |      |      |       |       |       |

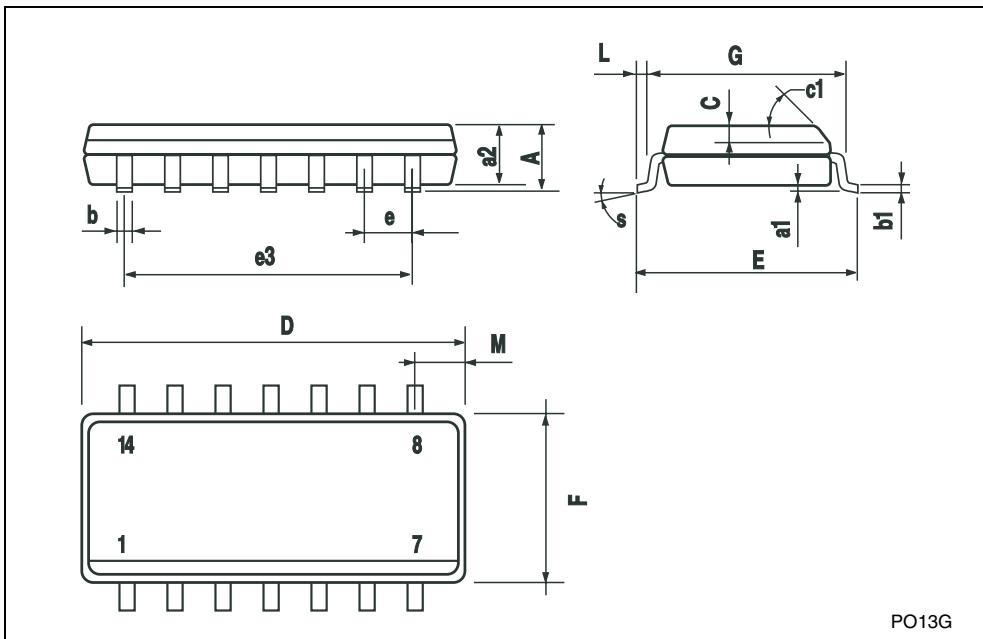

PO13G

## 6 Revision History

| Date       | Revision | Changes  |
|------------|----------|--|
| March 2001 | 1        | Initial release  |
| June 2005  | 2        | PIPAP references inserted in the datasheet see table order code p1 |

Information furnished is believed to be accurate and reliable. However, STMicroelectronics assumes no responsibility for the consequences of use of such information nor for any infringement of patents or other rights of third parties which may result from its use. No license is granted by implication or otherwise under any patent or patent rights of STMicroelectronics. Specifications mentioned in this publication are subject to change without notice. This publication supersedes and replaces all information previously supplied. STMicroelectronics products are not authorized for use as critical components in life support devices or systems without express written approval of STMicroelectronics.

The ST logo is a registered trademark of STMicroelectronics.  
All other names are the property of their respective owners

© 2005 STMicroelectronics - All rights reserved

STMicroelectronics group of companies

Australia - Belgium - Brazil - Canada - China - Czech Republic - Finland - France - Germany - Hong Kong - India - Israel - Italy - Japan - Malaysia - Malta - Morocco - Singapore - Spain - Sweden - Switzerland - United Kingdom - United States of America

[www.st.com](http://www.st.com)