

Dual Wide-Band Operational Amplifier with High Output Current

- Low noise: 2.5 nV/√Hz
- High output current: 420 mA
- Very low harmonic and intermodulation distortion
- High slew rate: 410 V/μs
- -3 dB bandwidth: 40 MHz @ gain = 12 dB on 25 Ω single-ended load
- 21.2 Vp-p differential output swing on 50 Ω load, 12 V power supply
- Current feedback structure
- 5 V to 12 V power supply
- Specified for 20 Ω and 50 Ω differential load
- Power down function with short-circuited output to keep matching with the line in sleep mode

Description

The TS615 is a dual operational amplifier featuring a high output current of 410 mA. This driver can be configured differentially for driving signals in telecommunication systems using multiple carriers. The TS615 is ideally suited for xDSL (High Speed Asymmetrical Digital Subscriber Line) applications. This circuit is capable of driving a 10 Ω or 25 Ω load on a range of power supplies: ±2.5 V, 5 V, ±6 V or +12 V. The TS615 is capable of reaching a -3 dB bandwidth of 40 MHz on a 25 Ω load with a 12 dB gain. This device is designed for high slew rates and demonstrates low harmonic distortion and intermodulation. The TS615 offers a power-down function to order to decrease power consumption. During sleep mode, the device short circuits its output in order to keep the impedance matched to the line. The TS615 is housed in TSSOP14 exposed-pad plastic package for a very low thermal resistance.

Order Codes

Part Number	Temperature Range	Package	Packaging	Marking
TS615IPWT	-40, +85°C	TSSOP (Thin Shrink Outline Package)	Tape & Reel	TS615

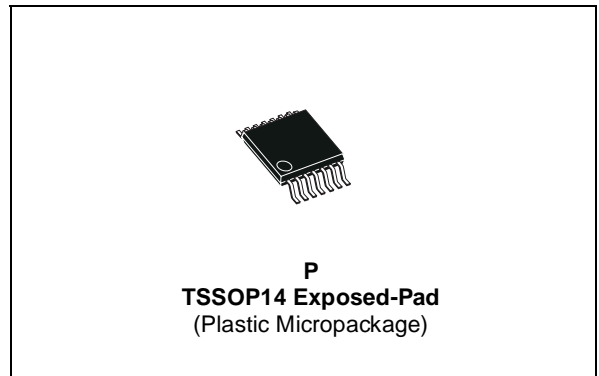

Pin Connections (top view)

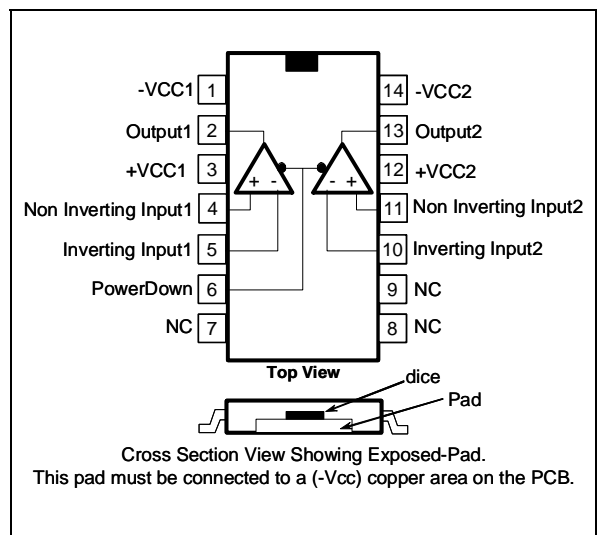

Applications

- Line driver for xDSL
- Multiple video line driver

1 Typical Application

Figure 1 shows a schematic of a typical xDSL application using the TS615.

Figure 1. Differential line driver for xDSL applications

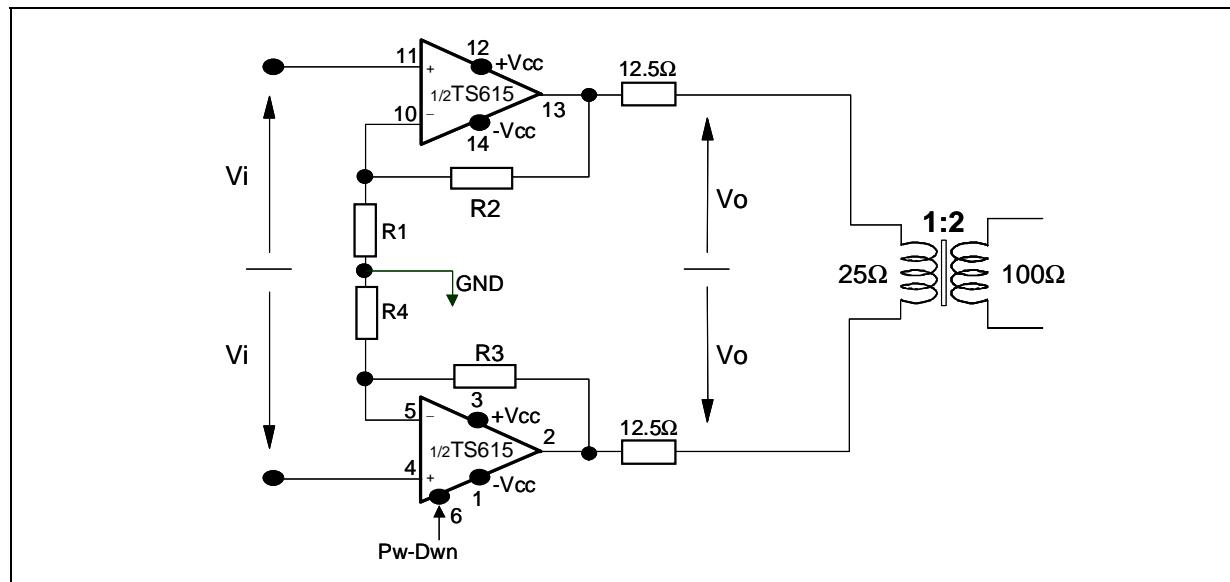

2 Absolute Maximum Ratings

Table 1. Key parameters and their absolute maximum ratings

Symbol	Parameter	Value	Unit
VCC	Supply voltage ¹	±7	V
V _{id}	Differential Input Voltage ²	±2	V
V _{in}	Input Voltage Range ³	±6	V
T _{oper}	Operating Free Air Temperature Range	-40 to + 85	°C
T _{std}	Storage Temperature	-65 to +150	°C
T _j	Maximum Junction Temperature	150	°C
R _{thjc}	Thermal Resistance Junction to Case	4	°C/W
R _{thja}	Thermal Resistance Junction to Ambient Area	40	°C/W
P _{max.}	Maximum Power Dissipation (@25°C)	3.1	W
ESD except pins 4, 5, 10, 11	CDM: Charged Device Model	1.5	kV
	HBM: Human Body Model	2	kV
	MM: Machine Model	200	V
ESD only pins 4, 5, 10, 11	CDM: Charged Device Model	1	kV
	HBM: Human Body Model	1	kV
	MM: Machine Model	100	V
	Output Short Circuit	4	

- 1) All voltage values, except differential voltage are with respect to network terminal.
- 2) Differential voltage are non-inverting input terminal with respect to the inverting input terminal.
- 3) The magnitude of input and output voltage must never exceed V_{CC} +0.3V.
- 4) An output current limitation protects the circuit from transient currents. Short-circuits can cause excessive heating. Destructive dissipation can result from short circuit on amplifiers.

Table 2. Operating conditions

Symbol	Parameter	Value	Unit
VCC	Power Supply Voltage	±2.5 to ±6	V
V _{icm}	Common Mode Input Voltage	-VCC+1.5V to +VCC-1.5V	V

3 Electrical Characteristics

Table 3. $V_{CC} = \pm 6V$, $R_{fb} = 910\Omega$, $T_{amb} = 25^\circ C$ (unless otherwise specified)

Symbol	Parameter	Test Condition	Min.	Typ.	Max.	Unit
DC performance						
V_{io}	Input Offset Voltage	T_{amb}		1.25	3.5	mV
		$T_{min.} < T_{amb} < T_{max.}$		2.1		
ΔV_{io}	Differential Input Offset Voltage	$T_{amb} = 25^\circ C$			2.5	mV
I_{ib+}	Positive Input Bias Current	T_{amb}		6	30	μA
		$T_{min.} < T_{amb} < T_{max.}$		7.8		
I_{ib-}	Negative Input Bias Current	T_{amb}		3	15	μA
		$T_{min.} < T_{amb} < T_{max.}$		3.2		
Z_{IN+}	Input(+) Impedance			82		k Ω
Z_{IN-}	Input(-) Impedance			54		Ω
C_{IN+}	Input(+) Capacitance			1		pF
CMR	Common Mode Rejection Ratio $20 \log (\Delta V_{ic} / \Delta V_{io})$	$\Delta V_{ic} = \pm 4.5V$	58	63		dB
		$T_{min.} < T_{amb} < T_{max.}$		61		
SVR	Supply Voltage Rejection Ratio $20 \log (\Delta V_{cc} / \Delta V_{io})$	$\Delta V_{cc} = \pm 2.5V$ to $\pm 6V$	72	79		dB
		$T_{min.} < T_{amb} < T_{max.}$		78		
I_{CC}	Total Supply Current per Operator	No load		14	17	mA
Dynamic performance and output characteristics						
R_{OL}	Open Loop Transimpedance	$V_{out} = 7Vp-p$, $R_L = 25\Omega$	5	21		M Ω
		$T_{min.} < T_{amb.} < T_{max.}$		8.9		
BW	-3dB Bandwidth	Small Signal $V_{out} < 20mVp$ $A_V = 12dB$, $R_L = 25\Omega$	25	40		MHz
	Full Power Bandwidth	Large Signal $V_{out} = 3Vp$ $A_V = 12dB$, $R_L = 25\Omega$		26		
	Gain Flatness @ 0.1dB	Small Signal $V_{out} < 20mVp$ $A_V = 12dB$, $R_L = 25\Omega$		7		
T_r	Rise Time	$V_{out} = 6Vp-p$, $A_V = 12dB$, $R_L = 25\Omega$		10.6		ns
T_f	Fall Time	$V_{out} = 6Vp-p$, $A_V = 12dB$, $R_L = 25\Omega$		12.2		ns
T_s	Settling Time	$V_{out} = 6Vp-p$, $A_V = 12dB$, $R_L = 25\Omega$		50		ns
SR	Slew Rate	$V_{out} = 6Vp-p$, $A_V = 12dB$, $R_L = 25\Omega$	330	410		V/ μs
V_{OH}	High Level Output Voltage	$R_L = 25\Omega$ Connected to GND	4.8	5.1		V
V_{OL}	Low Level Output Voltage	$R_L = 25\Omega$ Connected to GND		-5.5	-5.2	V
I_{out}	Output Sink Current	$V_{out} = -4Vp$	-350	-530		mA
		$T_{min.} < T_{amb} < T_{max.}$		-440		
	Output Source Current	$V_{out} = +4Vp$	330	420		
		$T_{min.} < T_{amb} < T_{max.}$		365		

Table 3. $V_{CC} = \pm 6V$, $R_{fb} = 910\Omega$, $T_{amb} = 25^\circ C$ (unless otherwise specified)

Symbol	Parameter	Test Condition	Min.	Typ.	Max.	Unit
Noise and distortion						
eN	Equivalent Input Noise Voltage	F = 100kHz		2.5		nV/ \sqrt{Hz}
iNp	Equivalent Input Noise Current (+)	F = 100kHz		15		pA/ \sqrt{Hz}
iNn	Equivalent Input Noise Current (-)	F = 100kHz		21		pA/ \sqrt{Hz}
HD2	2nd Harmonic distortion (differential configuration)	$V_{out} = 14V_{p-p}$, $A_V = 12dB$ F = 110kHz, $R_L = 50\Omega$ diff.		-87		dBc
HD3	3rd Harmonic distortion (differential configuration)	$V_{out} = 14V_{p-p}$, $A_V = 12dB$ F = 110kHz, $R_L = 50\Omega$ diff.		-83		dBc
IM2	2nd Order Intermodulation Product (differential configuration)	F1 = 100kHz, F2 = 110kHz $V_{out} = 16V_{p-p}$, $A_V = 12dB$ $R_L = 50\Omega$ diff.		-76		dBc
		F1 = 370kHz, F2 = 400kHz $V_{out} = 16V_{p-p}$, $A_V = 12dB$ $R_L = 50\Omega$ diff.		-75		
IM3	3rd Order Intermodulation Product (differential configuration)	F1 = 100kHz, F2 = 110kHz $V_{out} = 16V_{p-p}$, $A_V = 12dB$ $R_L = 50\Omega$ diff.		-88		dBc
		F1 = 370kHz, F2 = 400kHz $V_{out} = 16V_{p-p}$, $A_V = 12dB$ $R_L = 50\Omega$ diff.		-87		

Table 4. $V_{CC} = \pm 2.5V$, $R_{fb} = 910\Omega$, $T_{amb} = 25^\circ C$ (unless otherwise specified)

Symbol	Parameter	Test Condition	Min.	Typ.	Max.	Unit
DC performance						
V_{io}	Input Offset Voltage	T_{amb}		0.5	2.5	mV
		$T_{min.} < T_{amb} < T_{max.}$		1.2		
ΔV_{io}	Differential Input Offset Voltage	$T_{amb} = 25^\circ C$			2.5	mV
I_{ib+}	Positive Input Bias Current	T_{amb}		5	30	μA
		$T_{min.} < T_{amb} < T_{max.}$		8		
I_{ib-}	Negative Input Bias Current	T_{amb}		0.8	11	μA
		$T_{min.} < T_{amb} < T_{max.}$		1.24		
Z_{IN+}	Input(+) Impedance			71		k Ω
Z_{IN-}	Input(-) Impedance			62		Ω
C_{IN+}	Input(+) Capacitance			1.5		pF
CMR	Common Mode Rejection Ratio $20 \log (\Delta V_{ic} / \Delta V_{io})$	$\Delta V_{ic} = \pm 1V$	55	60		dB
		$T_{min.} < T_{amb.} < T_{max.}$		58		
SVR	Supply Voltage Rejection Ratio $20 \log (\Delta V_{cc} / \Delta V_{io})$	$\Delta V_{cc} = \pm 2V$ to $\pm 2.5V$	63	77		dB
		$T_{min.} < T_{amb.} < T_{max.}$		76		
I_{CC}	Total Supply Current per Operator	No load		11.9	15	mA
Dynamic performance and output characteristics						
R_{OL}	Open Loop Transimpedance	$V_{out} = 2Vp-p$, $R_L = 10\Omega$	2	5.4		M Ω
		$T_{min.} < T_{amb.} < T_{max.}$		2.1		
BW	-3dB Bandwidth	Small Signal $V_{out} < 20mVp$ $A_V = 12dB$, $R_L = 10\Omega$	20	30		MHz
	Full Power Bandwidth	Large Signal $V_{out} = 1.4Vp$ $A_V = 12dB$, $R_L = 10\Omega$		20		
	Gain Flatness @ 0.1dB	Small Signal $V_{out} < 20mVp$ $A_V = 12dB$, $R_L = 10\Omega$		5.7		MHz
T_r	Rise Time	$V_{out} = 2.8Vp-p$, $A_V = 12dB$ $R_L = 10\Omega$		11		ns
T_f	Fall Time	$V_{out} = 2.8Vp-p$, $A_V = 12dB$ $R_L = 10\Omega$		11.5		ns
T_s	Settling Time	$V_{out} = 2.2Vp-p$, $A_V = 12dB$ $R_L = 10\Omega$		39		ns
SR	Slew Rate	$V_{out} = 2.2Vp-p$, $A_V = 12dB$ $R_L = 10\Omega$	100	130		V/ μs
V_{OH}	High Level Output Voltage	$R_L = 10\Omega$ Connected to GND	1.5	1.75		V
V_{OL}	Low Level Output Voltage	$R_L = 10\Omega$ Connected to GND		-2.05	-1.8	V
I_{out}	Output Sink Current	$V_{out} = -1.25Vp$	-350	-470		mA
		$T_{min.} < T_{amb} < T_{max.}$		-450		
	Output Source Current	$V_{out} = +1.25Vp$	200	270		
		$T_{min.} < T_{amb} < T_{max.}$		245		

Table 4. $V_{CC} = \pm 2.5V$, $R_{fb} = 910\Omega$, $T_{amb} = 25^\circ C$ (unless otherwise specified)

Symbol	Parameter	Test Condition	Min.	Typ.	Max.	Unit
Noise and distortion						
eN	Equivalent Input Noise Voltage	F = 100kHz		2.5		nV/ \sqrt{Hz}
iNp	Equivalent Input Noise Current (+)	F = 100kHz		15		pA/ \sqrt{Hz}
iNn	Equivalent Input Noise Current (-)	F = 100kHz		21		pA/ \sqrt{Hz}
HD2	2nd Harmonic distortion (differential configuration)	$V_{out} = 6V_{p-p}$, $A_V = 12dB$ F = 110kHz, $R_L = 20\Omega$ diff.		-97		dBc
HD3	3rd Harmonic distortion (differential configuration)	$V_{out} = 6V_{p-p}$, $A_V = 12dB$ F = 110kHz, $R_L = 20\Omega$ diff.		-98		dBc
IM2	2nd Order Intermodulation Product (differential configuration)	F1 = 100kHz, F2 = 110kHz $V_{out} = 6V_{p-p}$, $A_V = 12dB$ $R_L = 20\Omega$ diff.		-86		dBc
		F1 = 370kHz, F2 = 400kHz $V_{out} = 6V_{p-p}$, $A_V = 12dB$ $R_L = 20\Omega$ diff.		-88		
IM3	3rd Order Intermodulation Product (differential configuration)	F1 = 100kHz, F2 = 110kHz $V_{out} = 6V_{p-p}$, $A_V = 12dB$ $R_L = 20\Omega$ diff.		-90		dBc
		F1 = 370kHz, F2 = 400kHz $V_{out} = 6V_{p-p}$, $A_V = 12dB$ $R_L = 20\Omega$ diff.		-85		

Power-down mode features

The power-down command is a MOS input featuring a high input impedance.

Table 5. $V_{CC} = \pm 2.5V$, $5V$, $\pm 6V$ or $12V$, $T_{amb} = 25^\circ C$

Symbol	Parameter	Min.	Typ.	Max.	Unit
V_{pdw}	Pin (6) Threshold Voltage for Power Down Mode				V
	Low Level	$-V_{CC}$		$-V_{CC} + 0.8$	
	High Level	$-V_{CC} + 2$		$+V_{CC}$	
$I_{CC_{pdw}}$	Power Down Mode Total Current Consumption @ $V_{CC} = 5V$		69	80	μA
	Power Down Mode Total Current Consumption @ $V_{CC} = 12V$		148	180	μA
R_{pdw}	Power Down Mode Output Impedance @ $V_{CC} = 5V$		19	23	Ω
	Power Down Mode Output Impedance @ $V_{CC} = 12V$		15.3	19	Ω
C_{pdw}	Power Down Mode Output Capacitance		63		pF

Power down control	Circuit status
$V_{pdw} = \text{Low Level}$	Active
$V_{pdw} = \text{High Level}$	Standby

Figure 2. Load configuration
Load: $R_L=25\Omega$, $V_{CC}=\pm 6V$

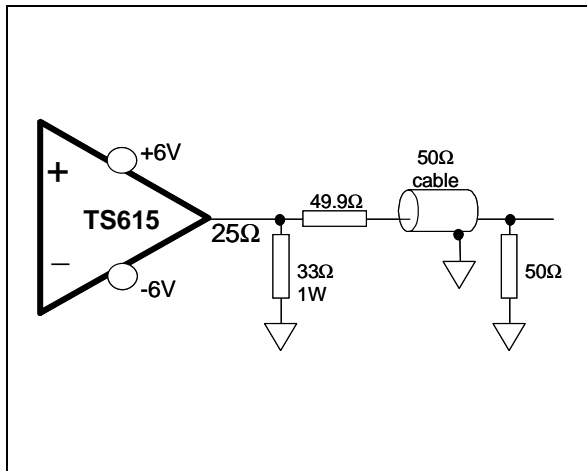

Figure 3. Closed loop gain vs. frequency
 $A_V=+1$

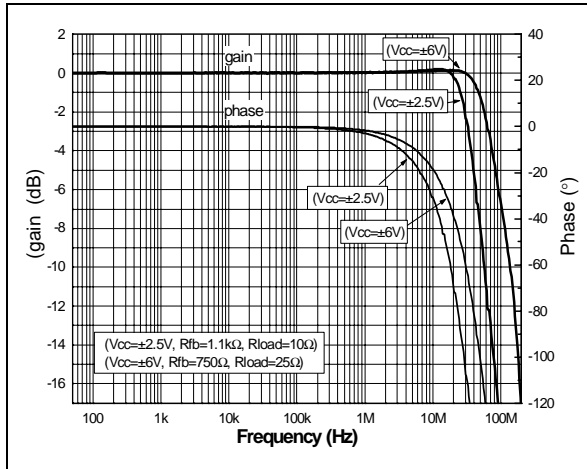

Figure 4. Closed loop gain vs. frequency
 $A_V=+2$

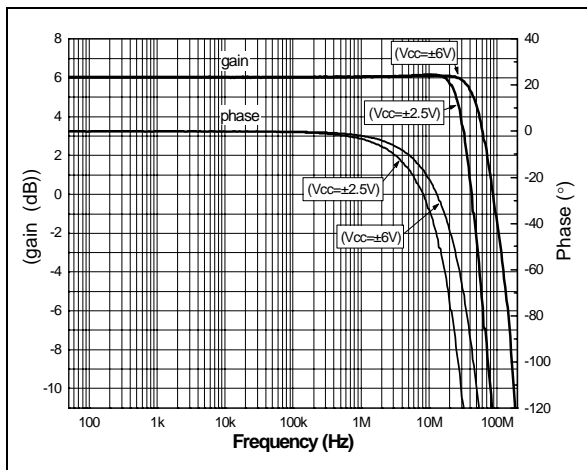

Figure 5. Load configuration
Load: $R_L=10\Omega$, $V_{CC}=\pm 2.5V$

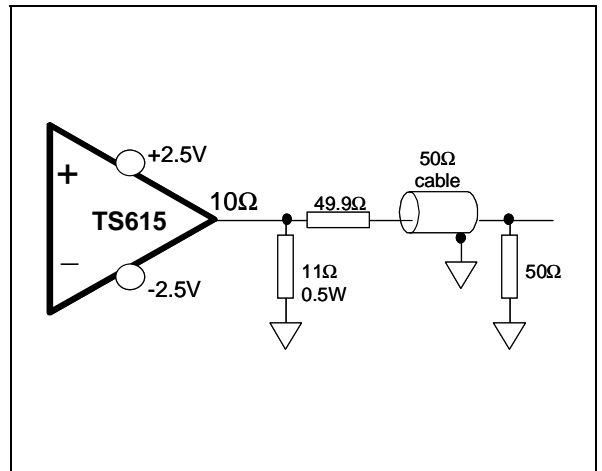

Figure 6. Closed loop gain vs. frequency
 $A_V=-1$

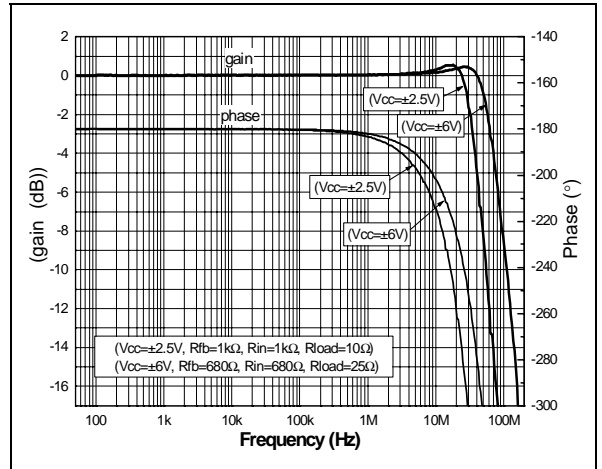

Figure 7. Closed loop gain vs. frequency
 $A_V=-2$

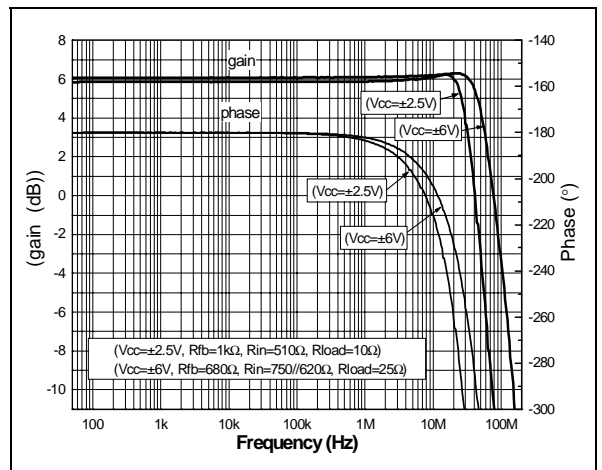

Figure 8. Closed loop gain vs. frequency
 $A_V=+4$

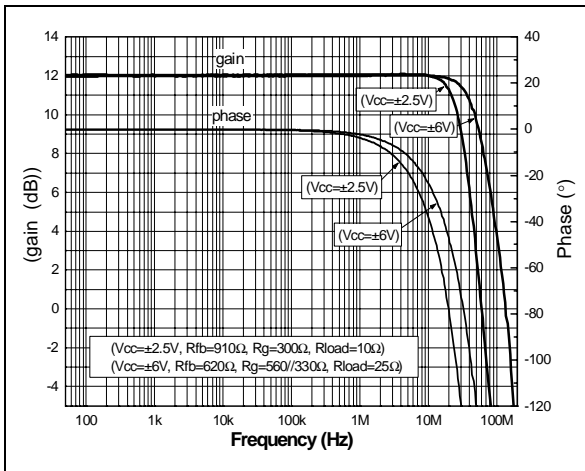

Figure 9. Closed loop gain vs. frequency
 $A_V=+8$

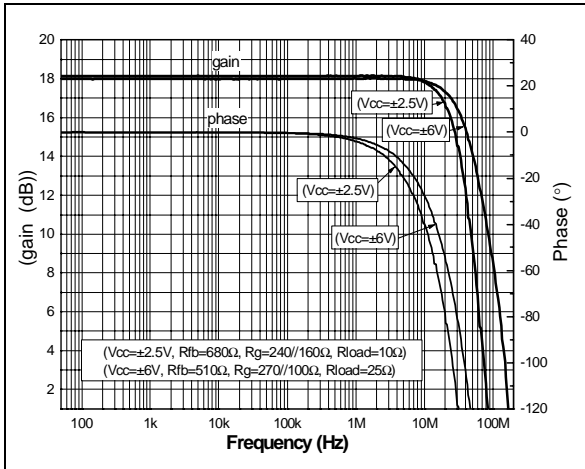

Figure 10. Bandwidth vs. temperature: $A_V=+4$,
 $R_{fb}=910\Omega$

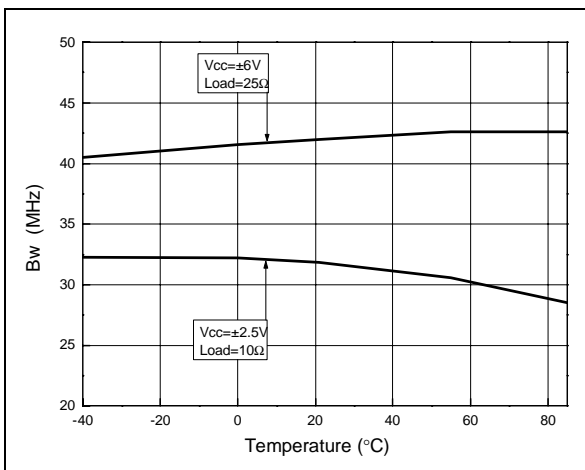

Figure 11. Closed loop gain vs. frequency
 $A_V=-4$

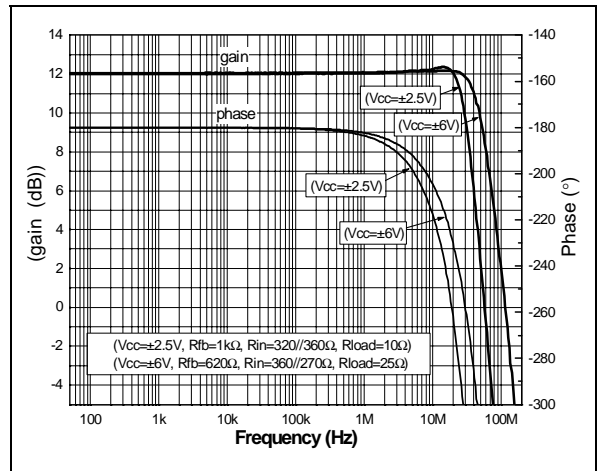

Figure 12. Closed loop gain vs. frequency
 $A_V=-8$

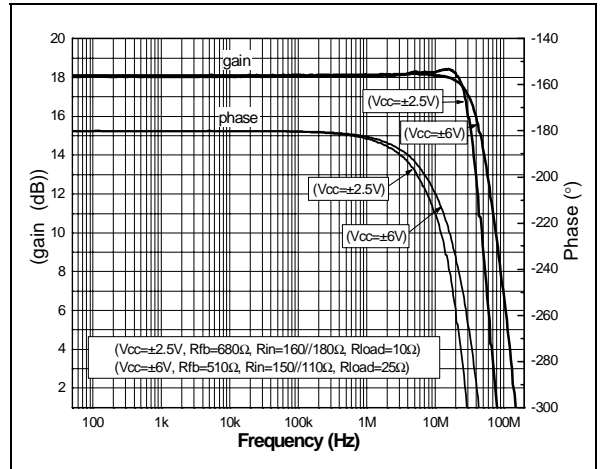

Figure 13. Positive slew rate: $A_V=+4$, $R_{fb}=620\Omega$,
 $V_{CC}=\pm 6V$, $R_L=25\Omega$

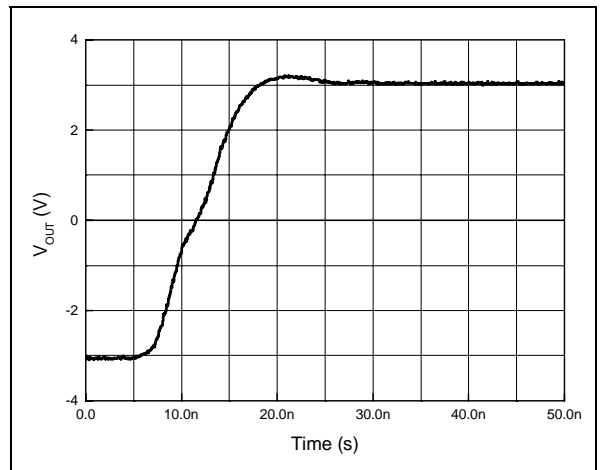

Figure 14. Positive slew rate: $A_V=+4$, $R_{fb}=910\Omega$, $V_{CC}=\pm 2.5V$, $R_L=10\Omega$

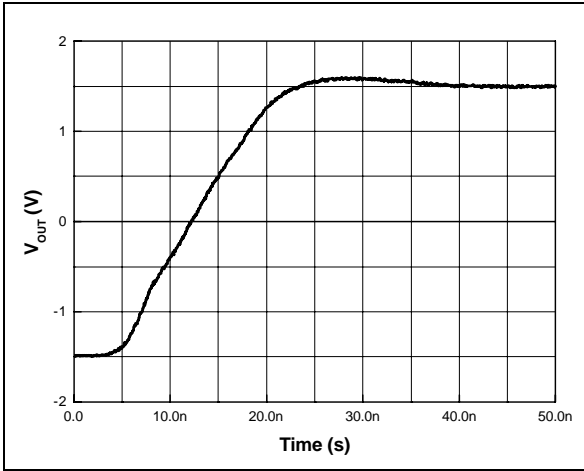

Figure 15. Negative slew rate: $A_V=+4$, $R_{fb}=620\Omega$, $V_{CC}=\pm 6V$, $R_L=25\Omega$

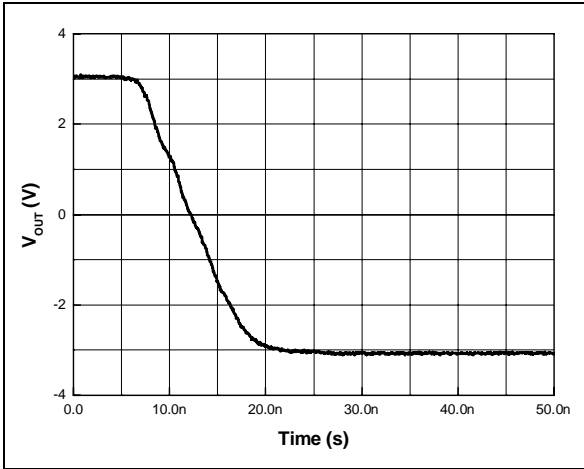

Figure 16. Negative slew rate: $A_V=+4$, $R_{fb}=910\Omega$, $V_{CC}=\pm 2.5V$, $R_L=10\Omega$

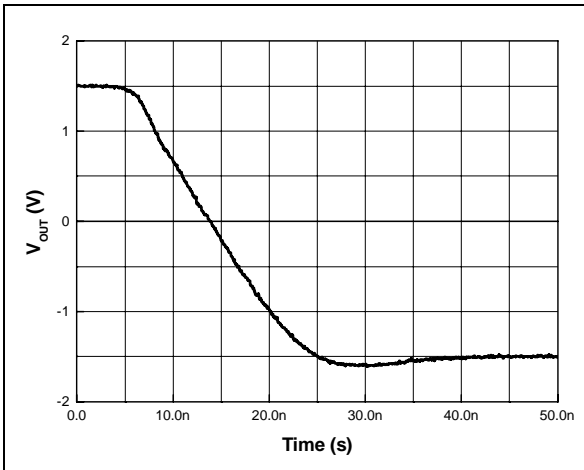

Figure 17. Positive slew rate: $A_V=-4$, $R_{fb}=620\Omega$, $V_{CC}=\pm 6V$, $R_L=25\Omega$

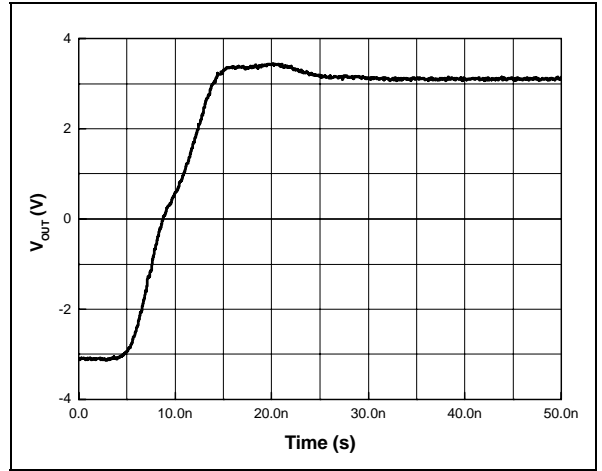

Figure 18. Positive slew rate: $A_V=-4$, $R_{fb}=910\Omega$, $V_{CC}=\pm 2.5V$, $R_L=10\Omega$

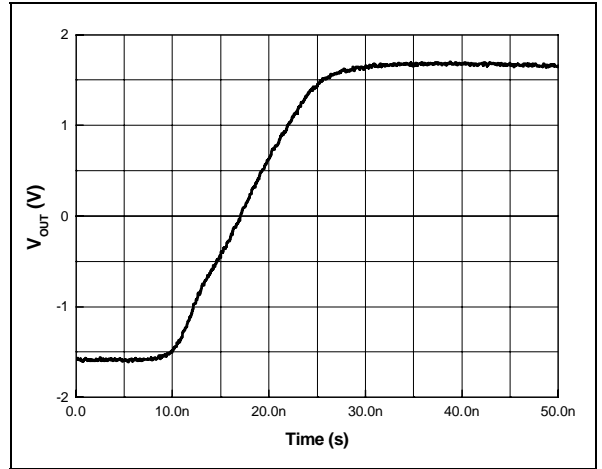

Figure 19. Negative slew rate: $A_V=-4$, $R_{fb}=620\Omega$, $V_{CC}=\pm 6V$, $R_L=25\Omega$

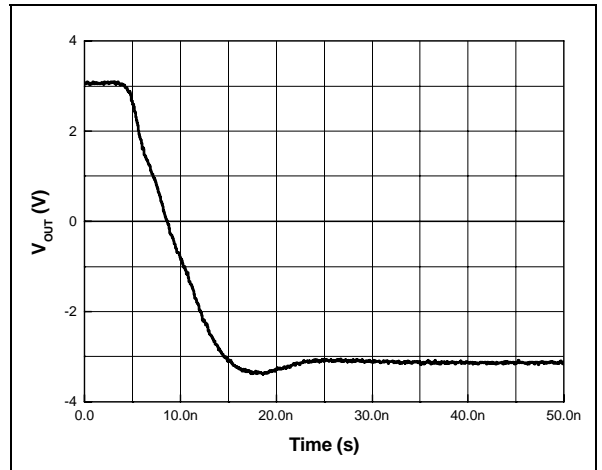

Figure 20. Negative slew rate: $A_V = -4$,
 $R_{fb} = 910\Omega$, $V_{CC} = \pm 2.5V$, $R_L = 10\Omega$

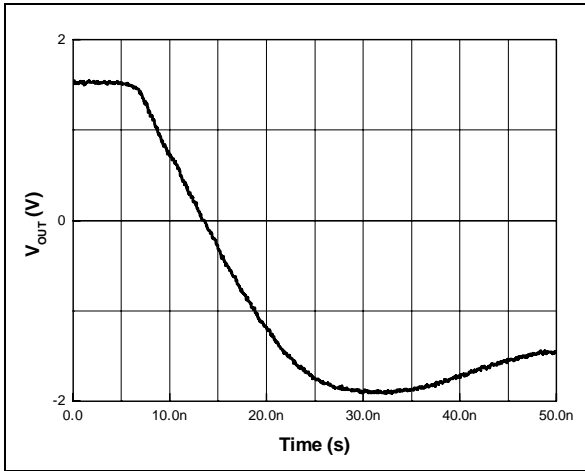

Figure 21. Slew rate vs. temperature: $A_V = +4$,
 $R_{fb} = 910\Omega$, $V_{CC} = \pm 2.5V$, $R_L = 10\Omega$

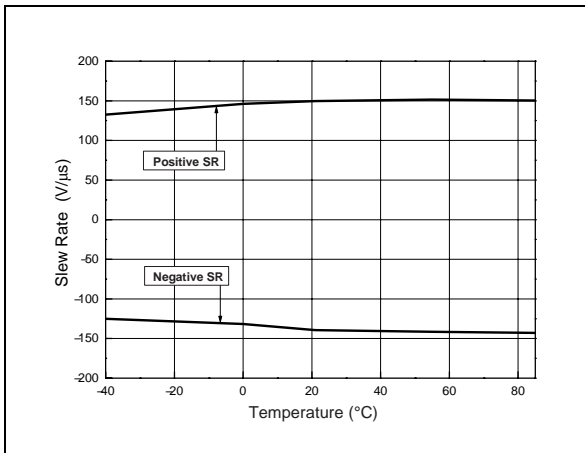

Figure 22. Slew rate vs. temperature: $A_V = +4$,
 $R_{fb} = 910\Omega$, $V_{CC} = \pm 6V$, $R_L = 25\Omega$

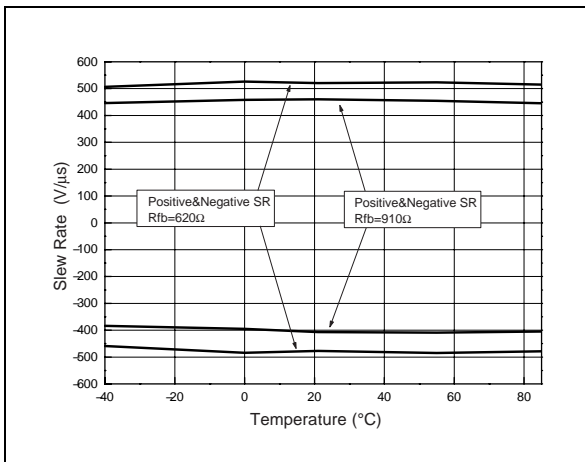

Figure 23. Input voltage noise level: $A_V = +92$,
 $R_{fb} = 910\Omega$, Input+ connected to Gnd via 10Ω

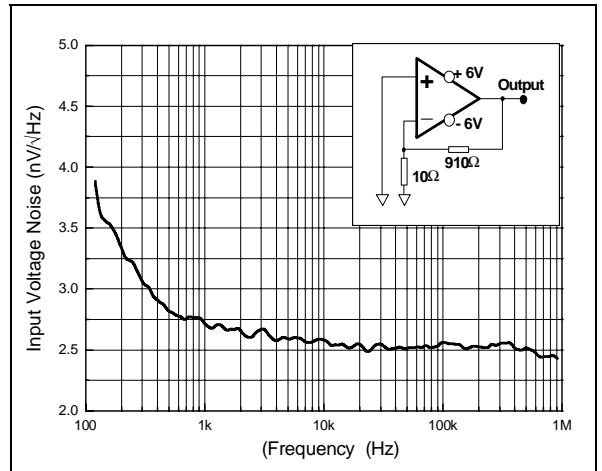

Figure 24. Transimpedance vs. temperature, open loop

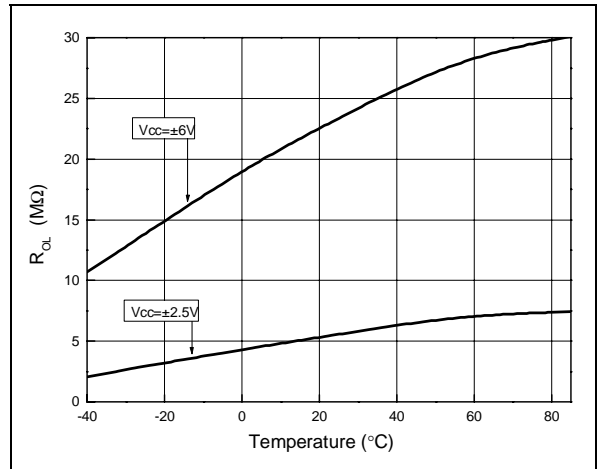

Figure 25. I_{CC} vs. power supply
 Open loop, no load

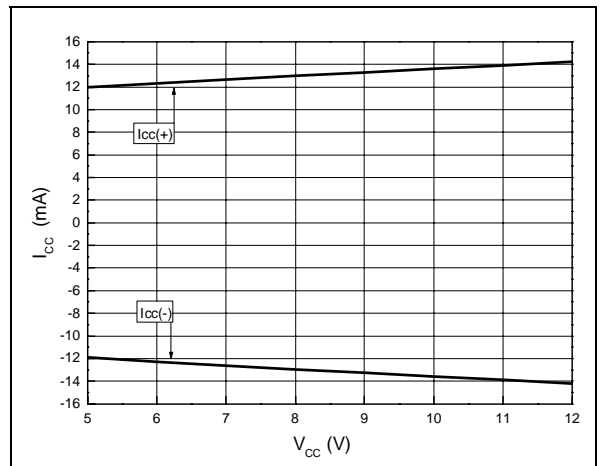

Figure 26. I_{ib} vs. power supply
Open loop, no load

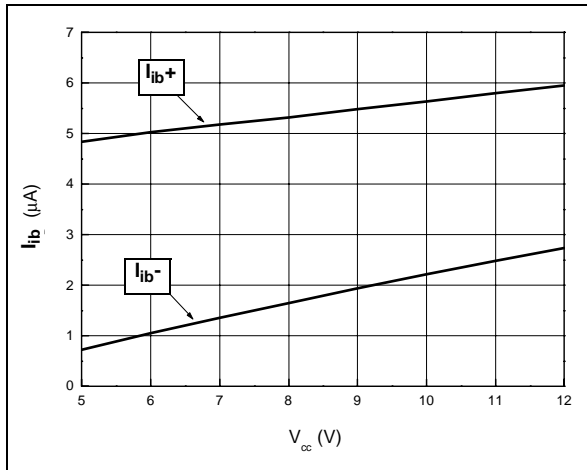

Figure 27. $I_{ib(-)}$ vs. temperature
Open loop, no load

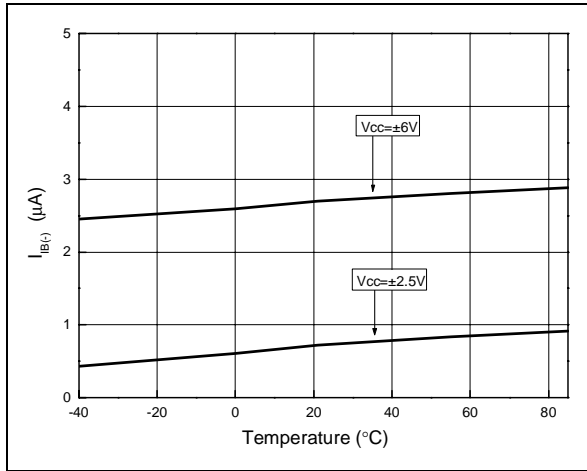

Figure 28. I_{cc} vs. temperature
Open loop, no load

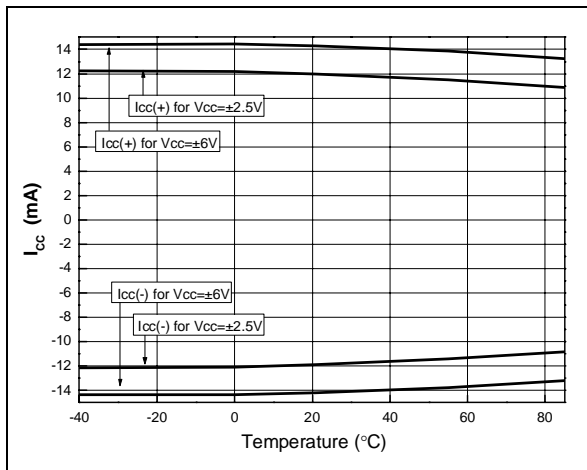

Figure 29. $I_{ib(+)}$ vs. temperature
Open loop, no load

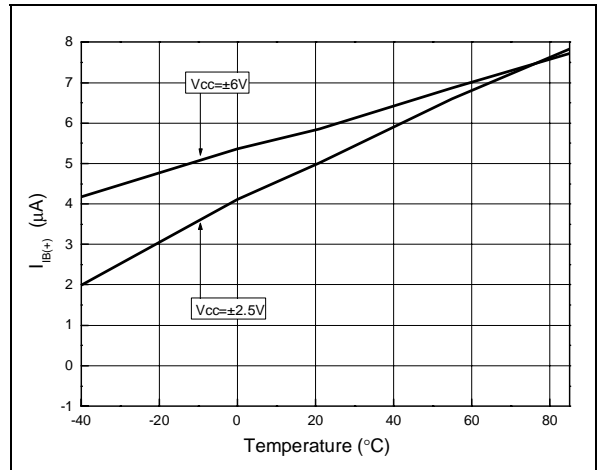

Figure 30. V_{oh} & V_{ol} vs. power supply
Open loop, $R_L = 25\Omega$

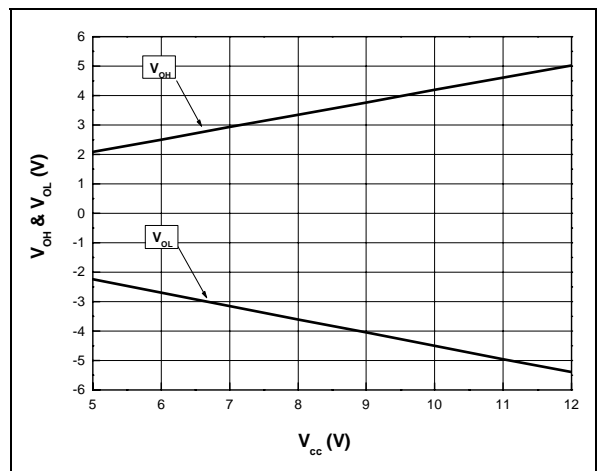

Figure 31. V_{oh} vs. temperature
Open loop

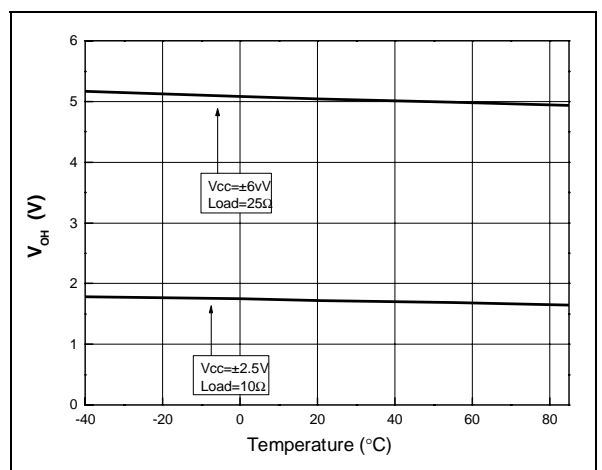

Figure 32. V_{ol} vs. temperature
Open loop

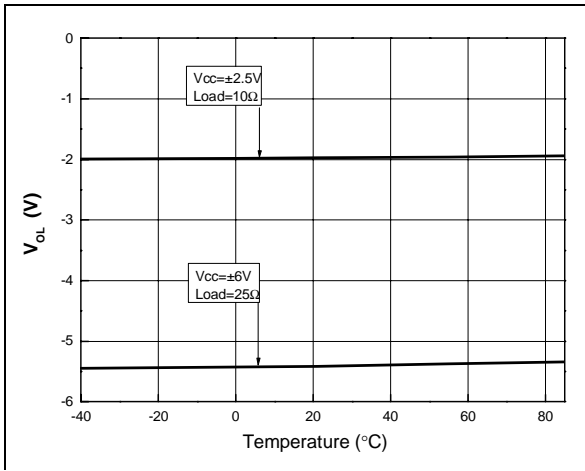

Figure 33. Differential V_{io} vs. temperature
Open loop, no load

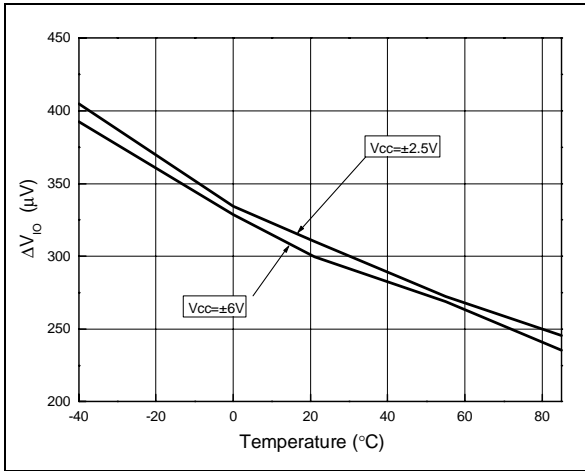

Figure 34. V_{io} vs. temperature
Open loop, no load

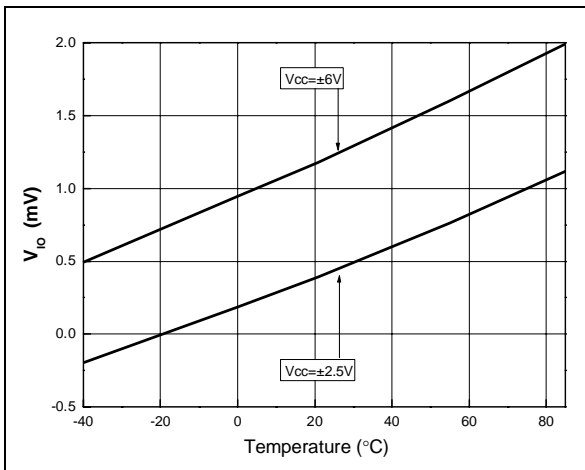

Figure 35. CMR vs. temperature
Open loop, no load

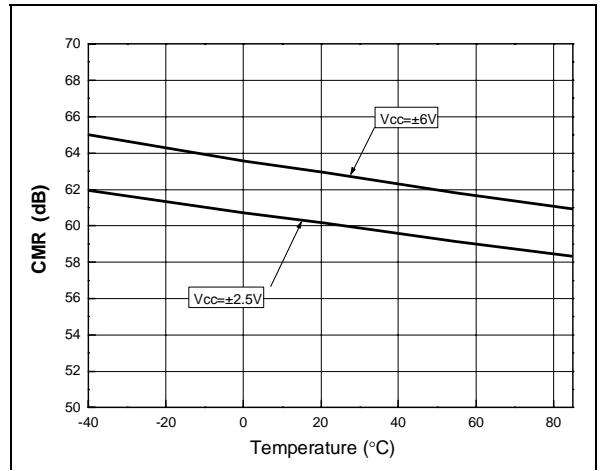

Figure 36. SVR vs. temperature
Open loop, no load

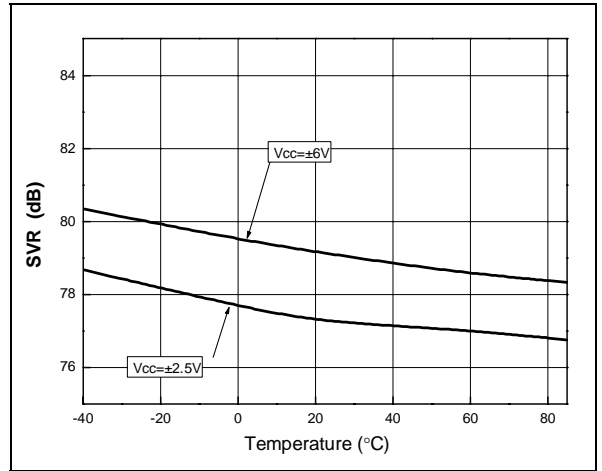

Figure 37. I_{out} vs. temperature
Open loop, $V_{CC}=\pm 6$ V, $R_L=10\Omega$

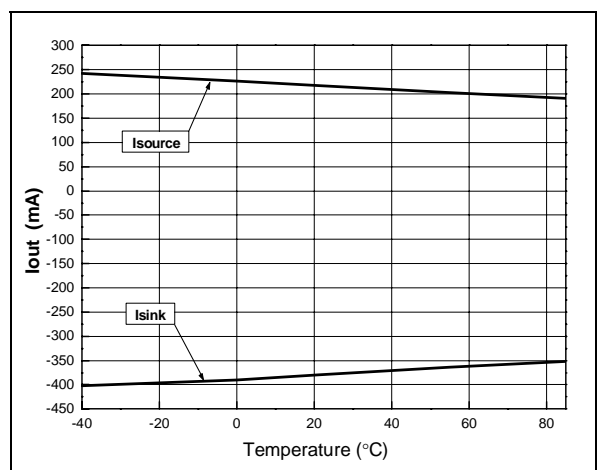

Figure 38. I_{out} vs. temperature
Open loop, V_{CC}=±2.5V, R_L=25Ω

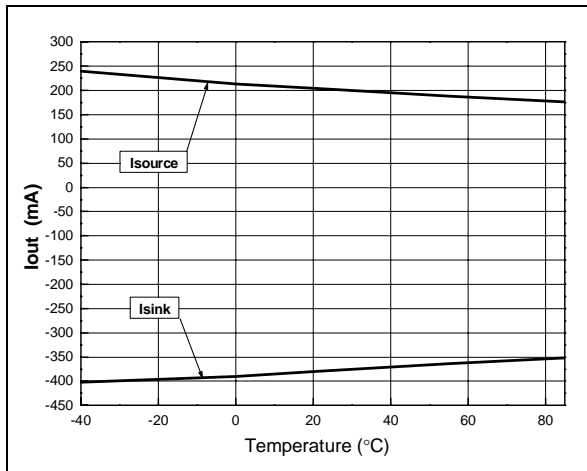

Figure 41. I_{source} vs. output amplitude
V_{CC}=±2.5V, open loop, no load

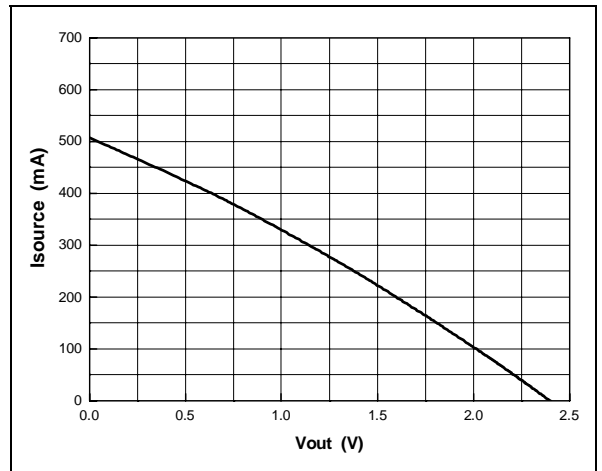

Figure 39. Maximum output amplitude vs. load: A_V=+4, R_{fb}=620Ω, V_{CC}=±6V

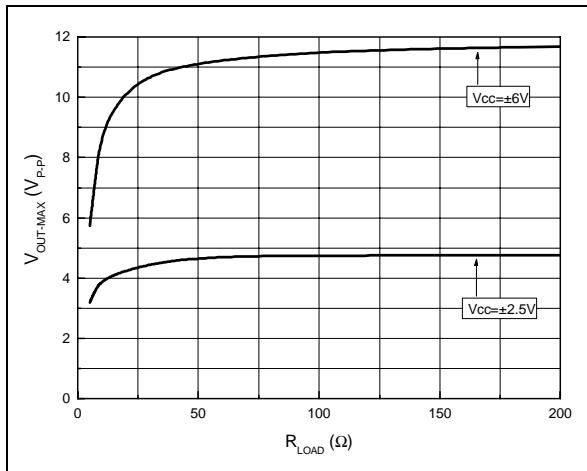

Figure 42. Isink vs. output amplitude
V_{CC}=±6V, open loop, no load

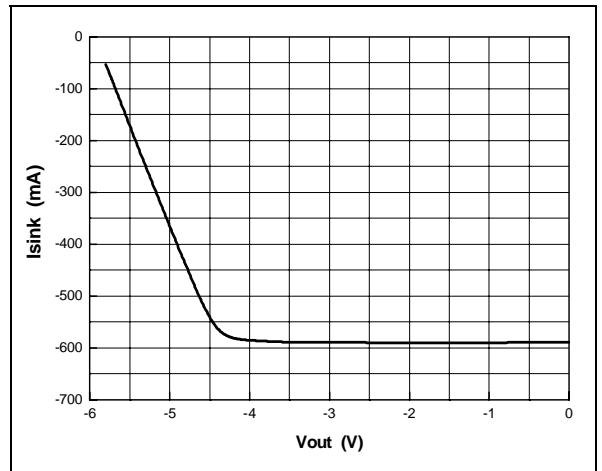

Figure 40. Isink vs. output amplitude
V_{CC}=±2.5V, open loop, no load

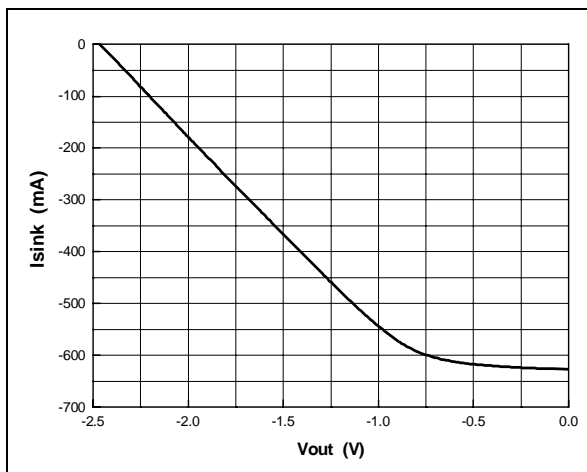

Figure 43. I_{source} vs. output amplitude
V_{CC}=±6V, open loop, no load

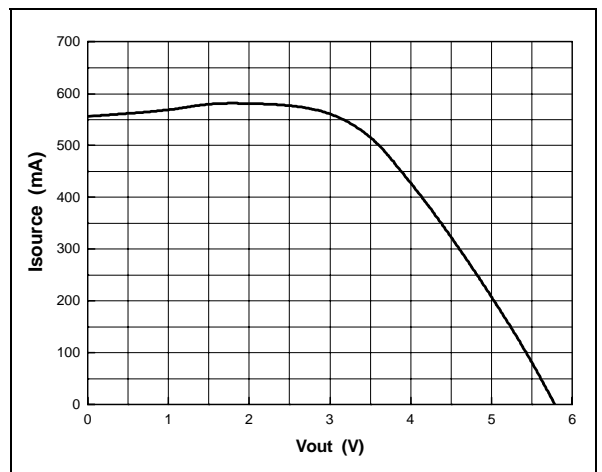
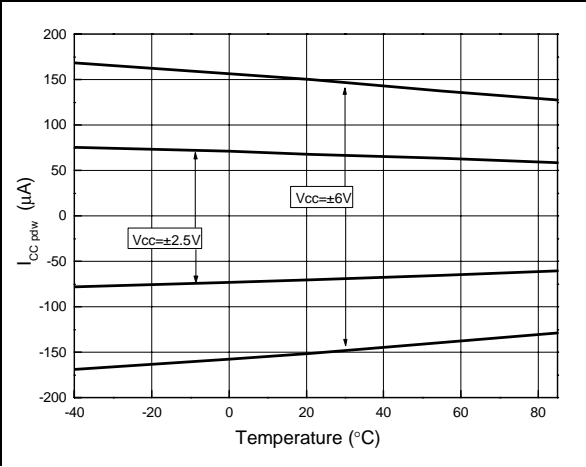

Figure 44. I_{CC} (power down) vs. temperature
no load, open loop



4 Safe Operating Area

Figure 45 shows the safe operating zone for the TS615. The curve shows the input level vs. the input frequency—a characteristic curve which must be considered in order to ensure a good application design. In the dash-lined zone, the consumption increases, and this increased consumption could do damage to the chip if the temperature increases

Figure 45. Safe operating area

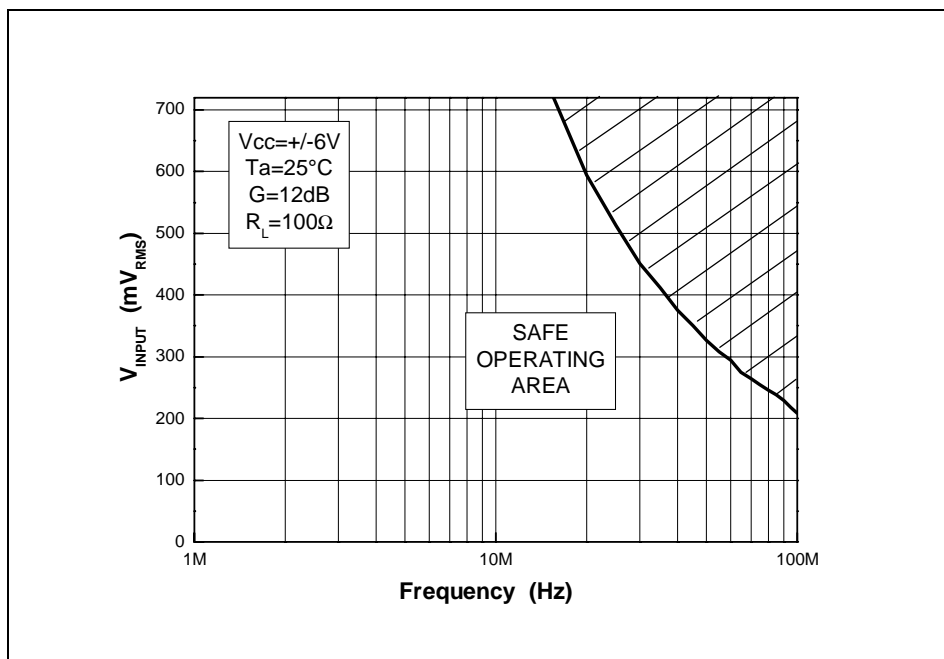

5 Intermodulation Distortion Product

The non-ideal output of the amplifier can be described by the following series, due to a non-linearity in the input-output amplitude transfer:

$$V_{out} = C_0 + C_1 V_{in} + C_2 V_{in}^2 \dots + C_n V_{in}^n$$

where the single-tone input is $V_{in}=A\sin\omega t$, and C_0 is the DC component, $C_1(V_{in})$ is the fundamental, C_n is the amplitude of the harmonics of the output signal V_{out} .

A one-frequency (one-tone) input signal contributes to a harmonic distortion. A two-tone input signal contributes to a harmonic distortion and an intermodulation product.

This intermodulation product, or rather, the study of the intermodulation distortion of a two-tone input signal is the first step in characterizing the amplifiers capability for driving multi-tone signals.

The two-tone input is equal to:

$$V_{in} = A \sin\omega_1 t + B \sin\omega_2 t$$

giving:

$$V_{out} = C_0 + C_1(A \sin\omega_1 t + B \sin\omega_2 t) + C_2(A \sin\omega_1 t + B \sin\omega_2 t)^2 \dots + C_n(A \sin\omega_1 t + B \sin\omega_2 t)^n$$

In this expression, we can extract distortion terms and intermodulations terms from a single sine wave: second-order intermodulation terms IM2 by the frequencies $(\omega_1-\omega_2)$ and $(\omega_1+\omega_2)$ with an amplitude of C_2A^2 and third-order intermodulation terms IM3 by the frequencies $(2\omega_1-\omega_2)$, $(2\omega_1+\omega_2)$, $(-\omega_1+2\omega_2)$ and $(\omega_1+2\omega_2)$ with an amplitude of $(3/4)C_3A^3$.

We can measure the intermodulation product of the driver by using the driver as a mixer via a summing amplifier configuration. In doing this, the non-linearity problem of an external mixing device is avoided.

Figure 46. Non-inverting summing amplifier

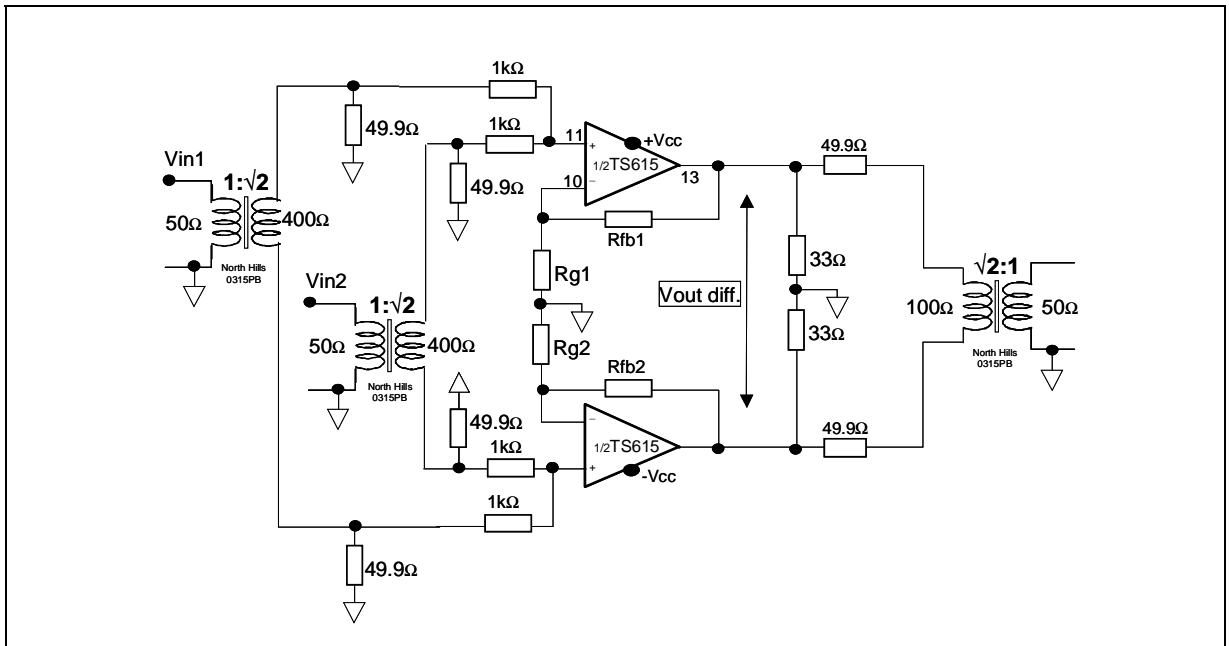

The following graphs show the IM2 and the IM3 of the amplifier in different configurations. The two-tone input signal is created by a Marconi 2026 multisource generator. Each tone has the same amplitude. The measurement was carried out using an HP3585A spectrum analyzer.

Figure 47. Intermodulation vs. output amplitude: 370 kHz & 400 kHz, $A_V = +1.5$, $R_{fb} = 1\text{ k}\Omega$, $R_L = 14\ \Omega$ diff., $V_{CC} = \pm 2.5\text{ V}$

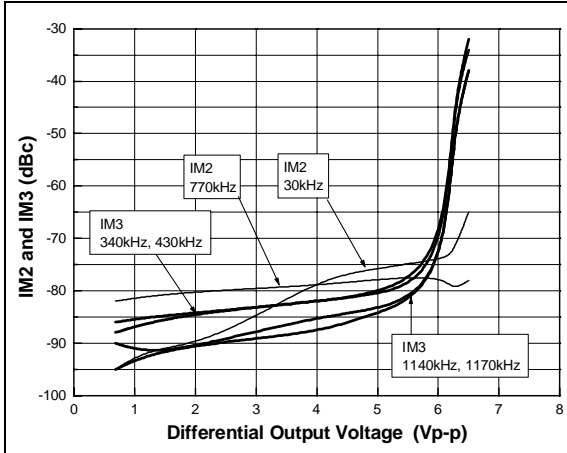

Figure 48. Intermodulation vs. output amplitude: 370 kHz & 400 kHz, $A_V = +1.5$, $R_{fb} = 1\text{ k}\Omega$, $R_L = 28\ \Omega$ diff., $V_{CC} = \pm 2.5\text{ V}$

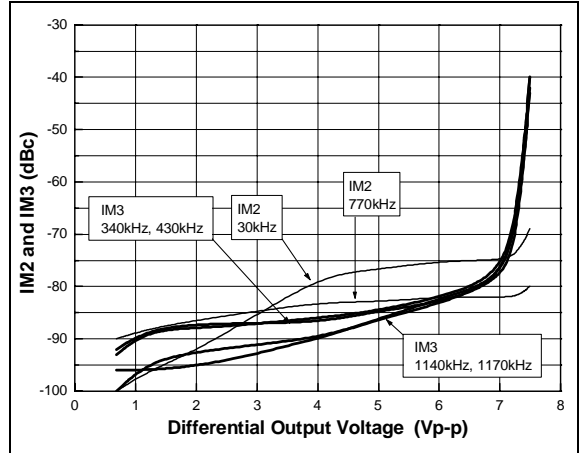

Figure 49. Intermodulation vs. gain: 370kHz & 400kHz, $R_L=20\ \Omega$ diff., $V_{out}=6V_{pp}$, $V_{CC}=\pm 2.5V$

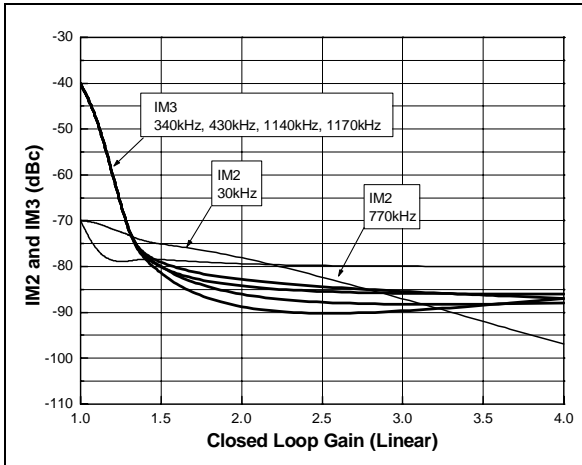

Figure 50. Intermodulation vs. Load: 370kHz & 400kHz, $A_V=+1.5$, $R_{fb}=1\text{ k}\Omega$, $V_{out}=6.5V_{pp}$, $V_{CC}=\pm 2.5V$

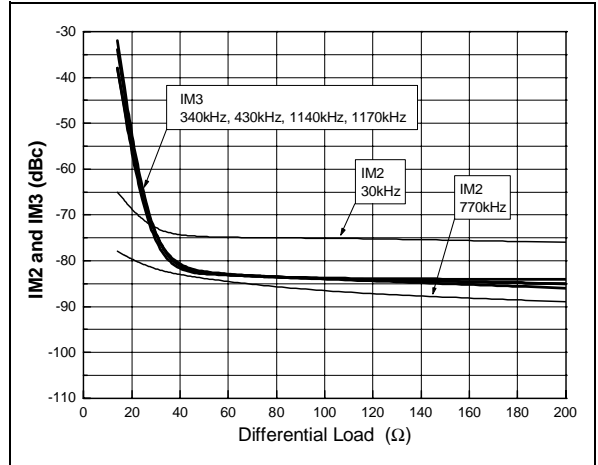

Figure 51. Intermodulation vs. Output Amplitude:
 100kHz & 110kHz, $A_V=+4$, $R_{fb}=620\Omega$, $R_L=200\Omega$ diff.,
 $V_{CC}=\pm 6V$

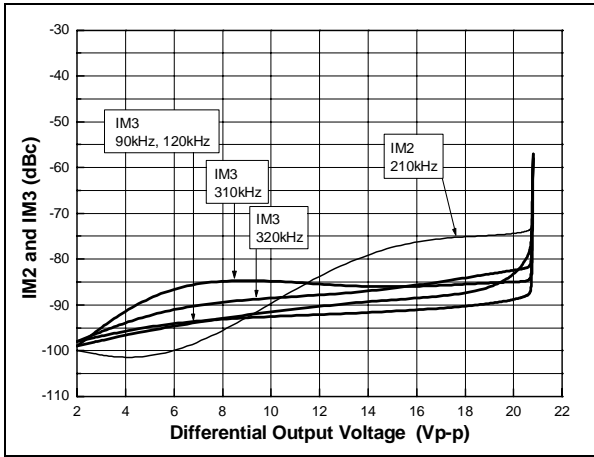

Figure 52. Intermodulation vs. Output Amplitude:
 100kHz & 110kHz, $A_V=+4$, $R_{fb}=620\Omega$, $R_L=50\Omega$ diff.,
 $V_{CC}=\pm 6V$

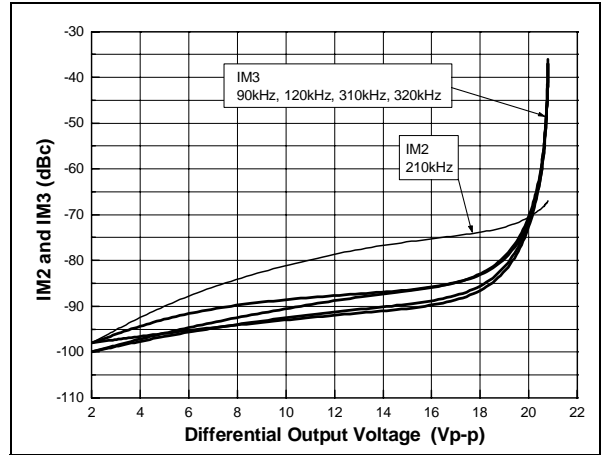

Figure 53. Intermodulation vs. Frequency Range:
 $A_V=+4$, $R_{fb}=620\Omega$, $R_L=50\Omega$ diff., $V_{out}=16V_{pp}$,
 $V_{CC}=\pm 6V$

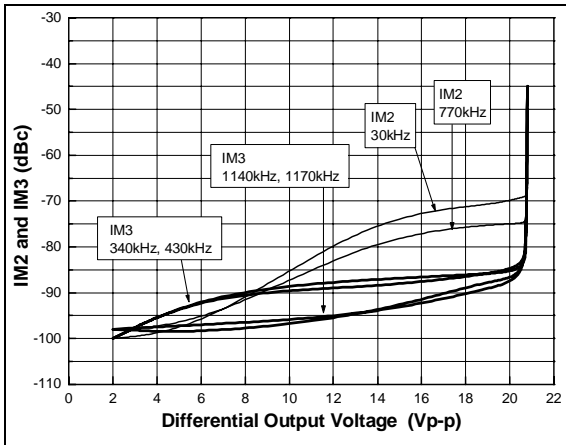
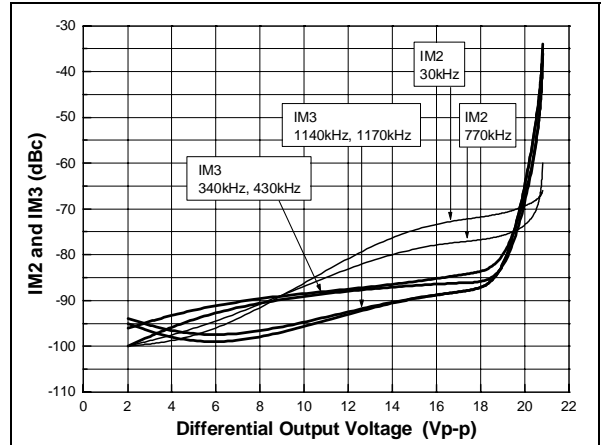

Figure 54. Intermodulation vs. Output Amplitude:
 370kHz & 400kHz, $A_V=+4$, $R_{fb}=620\Omega$, $R_L=50\Omega$ diff.,
 $V_{CC}=\pm 6V$



6 Printed Circuit Board Layout Considerations

In the ADSL frequency range, printed circuit board parasites can affect the closed-loop performance.

The use of a proper ground plane on both sides of the PCB is necessary to provide low inductance and a low resistance common return. The most important factors affecting gain flatness and bandwidth are stray capacitance at the output and inverting input. To minimize capacitance, the space between signal lines and ground plane should be maximized. Feedback component connections must be as short as possible in order to decrease the associated inductance which affects high-frequency gain errors. It is very important to choose the smallest possible external components—for example, surface mounted devices (SMD)—in order to minimize the size of all DC and AC connections.

6.1 Thermal information

The TS615 is housed in an exposed-pad plastic package. As described in [Figure 55](#), this package has a lead frame upon which the dice is mounted. This lead frame is exposed as a thermal pad on the underside of the package. The thermal contact is direct with the dice. This thermal path provides an excellent thermal performance.

The thermal pad is electrically isolated from all pins in the package. It must be soldered to a copper area of the PCB underneath the package. Through these thermal paths within this copper area, heat can be conducted away from the package. The copper area **must** be connected to $-V_{CC}$ available on pin 4.

Figure 55. Exposed-pad package

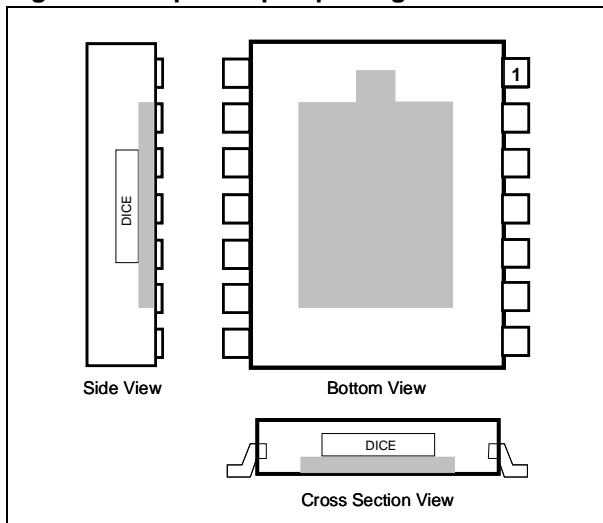

Figure 56. Evaluation board

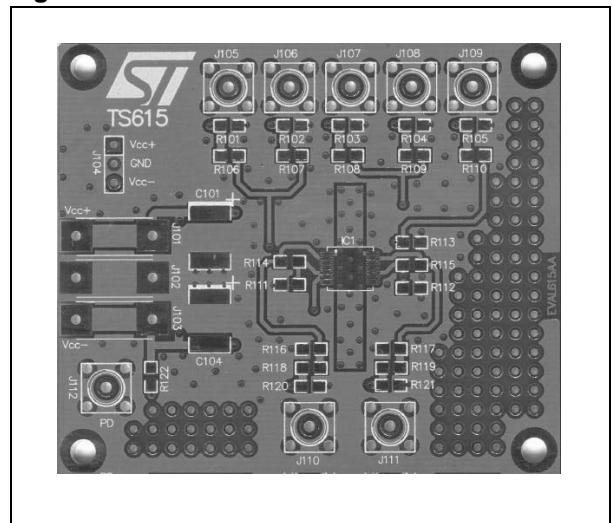

Figure 57. Schematic diagram

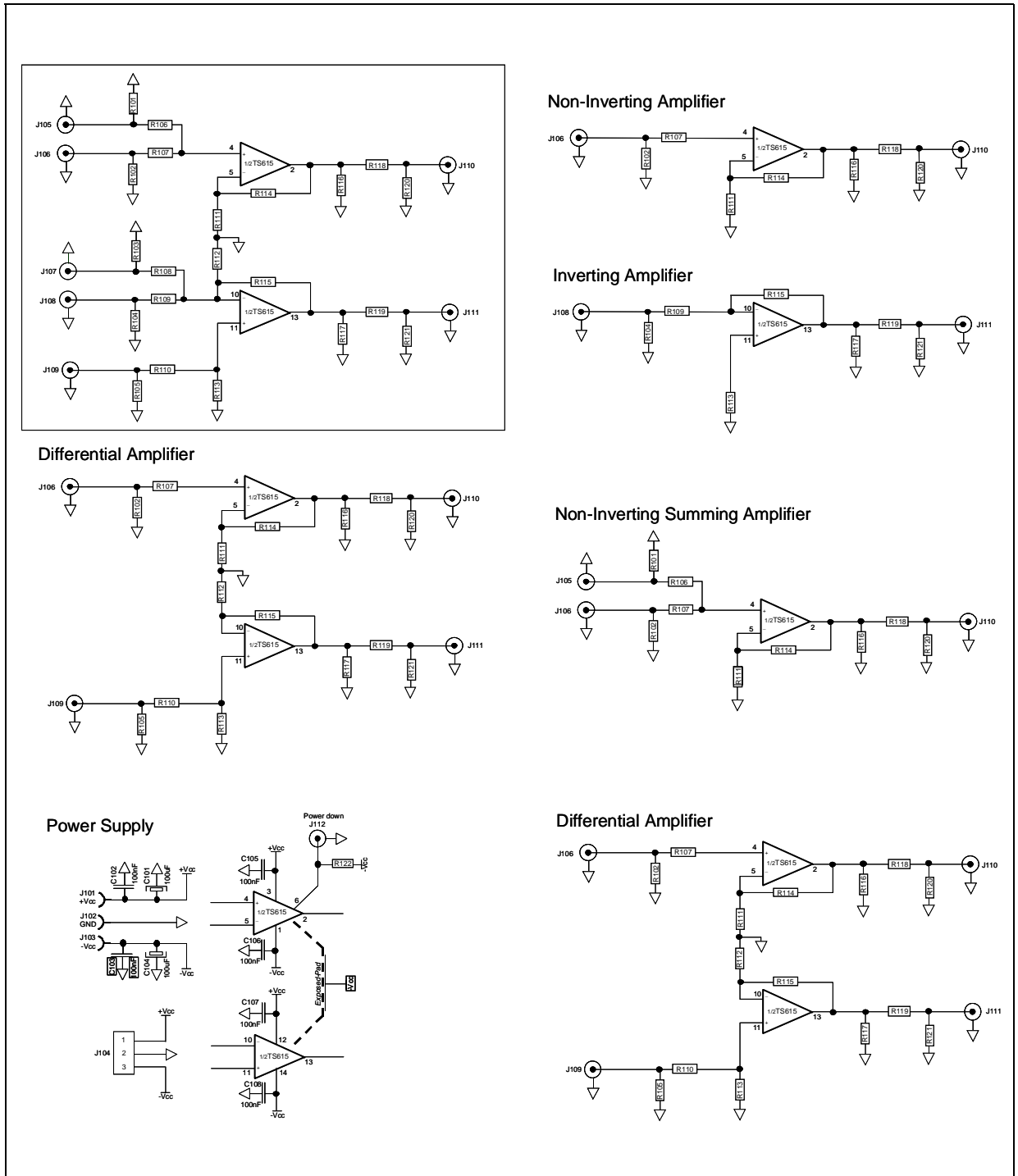

Figure 58. Component locations - top side

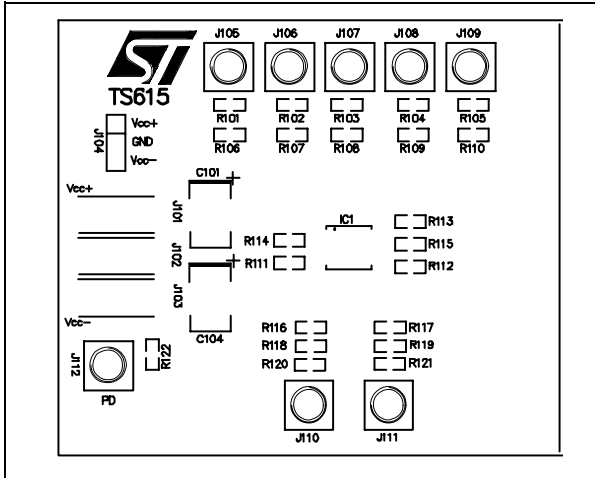

Figure 59. Component locations - bottom side

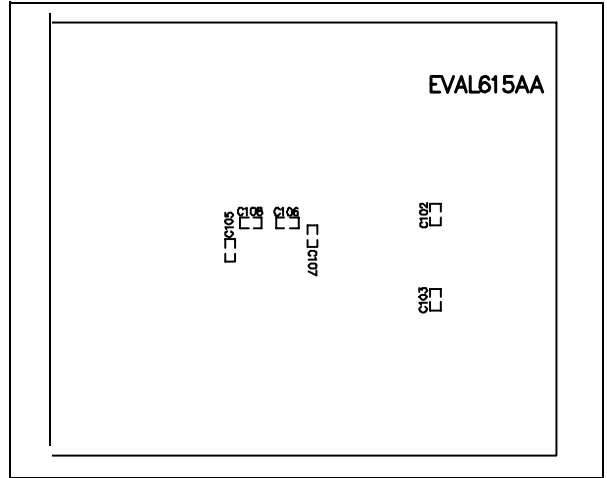

Figure 60. Top side board layout

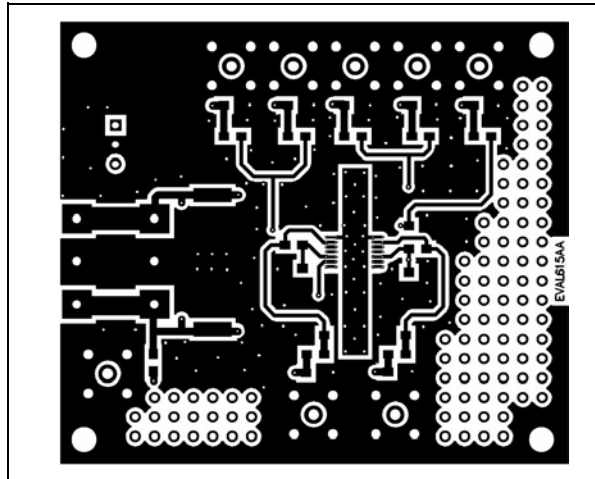
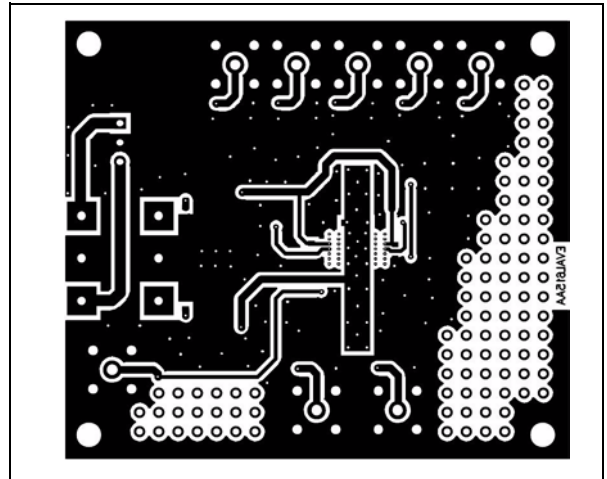

Figure 61. Bottom side board layout



7 Noise Measurements

The noise model is shown in [Figure 62](#), where:

- eN : input voltage noise of the amplifier
- iNn : negative input current noise of the amplifier
- iNp : positive input current noise of the amplifier

Figure 62. Noise model

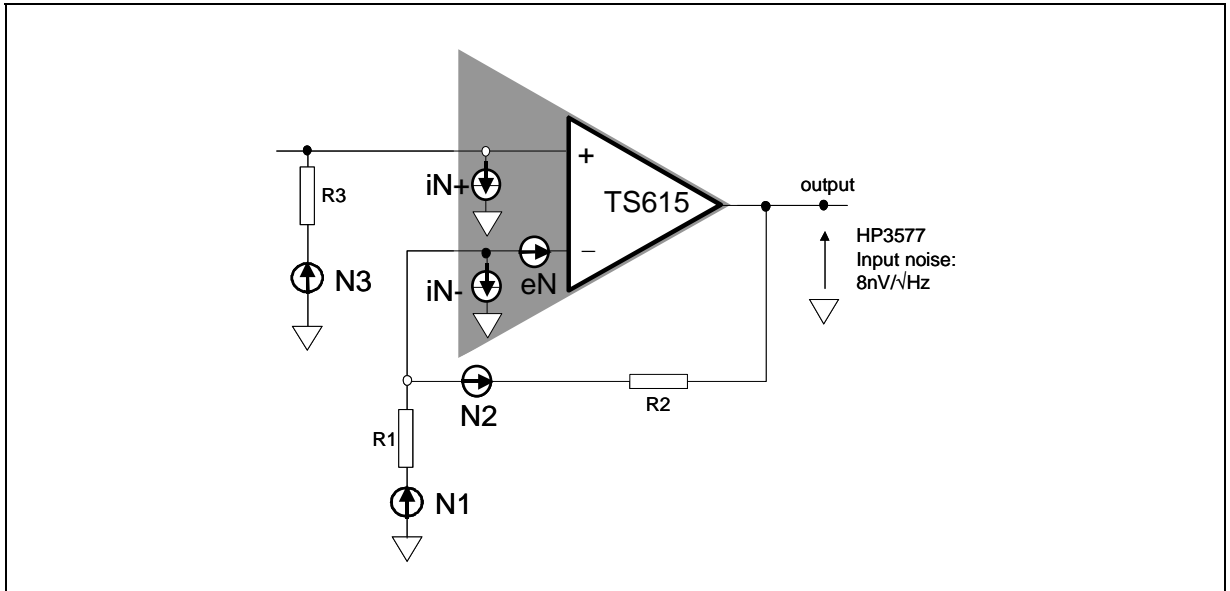

The closed loop gain is:

$$A_V = g = 1 + \frac{R_{fb}}{R_g}$$

The six noise sources are:

$$V1 = eN \times \left(1 + \frac{R2}{R1}\right)$$

$$V2 = iNn \times R2$$

$$V3 = iNp \times R3 \times \left(1 + \frac{R2}{R1}\right)$$

$$V4 = -\frac{R2}{R1} \times \sqrt{4kTR1}$$

$$V5 = \sqrt{4kTR2}$$

$$V6 = \left(1 + \frac{R2}{R1}\right) \sqrt{4kTR3}$$

We assume that the thermal noise of a resistance R is:

$$\sqrt{4kTR\Delta F}$$

where ΔF is the specified bandwidth.

On a 1Hz bandwidth the thermal noise is reduced to

$$\sqrt{4kTR}$$

where k is Boltzmann's constant, equals to $1374 \times 10^{-23} \text{ J/}^\circ\text{K}$. T is the temperature ($^\circ\text{K}$).

The output noise eNo is calculated using the Superposition Theorem. However eNo is not the sum of all noise sources, but rather the square root of the sum of the square of each noise source, as shown in [Equation 1](#).

$$eNo = \sqrt{V1^2 + V2^2 + V3^2 + V4^2 + V5^2 + V6^2} \quad \text{Equation 1}$$

$$\begin{aligned} eNo^2 = & eN^2 \times g^2 + iNn^2 \times R2^2 + iNp^2 \times R3^2 \times g^2 \\ & \dots + \left(\frac{R2}{R1}\right)^2 \times 4kTR1 + 4kTR2 + \left(1 + \frac{R2}{R1}\right)^2 \times 4kTR3 \end{aligned} \quad \text{Equation 2}$$

The input noise of the instrumentation must be extracted from the measured noise value. The real output noise value of the driver is:

$$eNo = \sqrt{(\text{Measured})^2 - (\text{instrumentation})^2} \quad \text{Equation 3}$$

The input noise is called the Equivalent Input Noise as it is not directly measured but is evaluated from the measurement of the output divided by the closed loop gain (eNo/g).

After simplification of the fourth and the fifth term of [Equation 2](#) we obtain:

$$eNo^2 = eN^2 \times g^2 + iNn^2 \times R2^2 + iNp^2 \times R3^2 \times g^2 \dots + g \times 4kTR2 + \left(1 + \frac{R2}{R1}\right)^2 \times 4kTR3 \quad \text{Equation 4}$$

7.1 Measurement of eN

If we assume a short-circuit on the non-inverting input ($R3=0$), [Equation 4](#) becomes:

$$eNo = \sqrt{eN^2 \times g^2 + iNn^2 \times R2^2 + g \times 4kTR2} \quad \text{Equation 5}$$

In order to easily extract the value of eN , the resistance $R2$ will be chosen as low as possible. On the other hand, the gain must be large enough:

- **R1=10Ω, R2=910Ω, R3=0, Gain=92**
- **Equivalent Input Noise:** 2.57nV/ $\sqrt{\text{Hz}}$
- **Input Voltage Noise:** $eN=2.5\text{nV}/\sqrt{\text{Hz}}$

7.2 Measurement of iN_n

To measure the negative input current noise iN_n , we set $R_3=0$ and use [Equation 5](#). This time the gain must be lower in order to decrease the thermal noise contribution:

- **$R_1=100\Omega$, $R_2=910\Omega$, $R_3=0$, gain=10.1**
- **Equivalent input noise:** $3.40\text{nV}/\sqrt{\text{Hz}}$
- **Negative input current noise:** $iN_n = 21\text{pA}/\sqrt{\text{Hz}}$

7.3 Measurement of iN_p

To extract iN_p from [Equation 3](#), a resistance R_3 is connected to the non-inverting input. The value of R_3 must be chosen in order to keep its thermal noise contribution as low as possible against the iN_p contribution.

- **$R_1=100\Omega$, $R_2=910\Omega$, $R_3=100\Omega$, Gain=10.1**
- **Equivalent input noise:** $3.93\text{nV}/\sqrt{\text{Hz}}$
- **Positive input current noise:** $iN_p=15\text{pA}/\sqrt{\text{Hz}}$
- **Conditions:** Frequency=100kHz, $V_{CC}=\pm 2.5\text{V}$
- **Instrumentation:** HP3585A Spectrum Analyzer (the input noise of the HP3585A is $8\text{nV}/\sqrt{\text{Hz}}$)

8 Power Supply Bypassing

Correct power supply bypassing is very important for optimizing performance in high-frequency ranges. Bypass capacitors should be placed as close as possible to the IC pins to improve high-frequency bypassing. A capacitor greater than $1\mu\text{F}$ is necessary to minimize the distortion. For a better quality bypassing, a capacitor of 10nF is added using the same implementation conditions. Bypass capacitors must be incorporated for both the negative and the positive supply.

Figure 63. Circuit for power supply bypassing

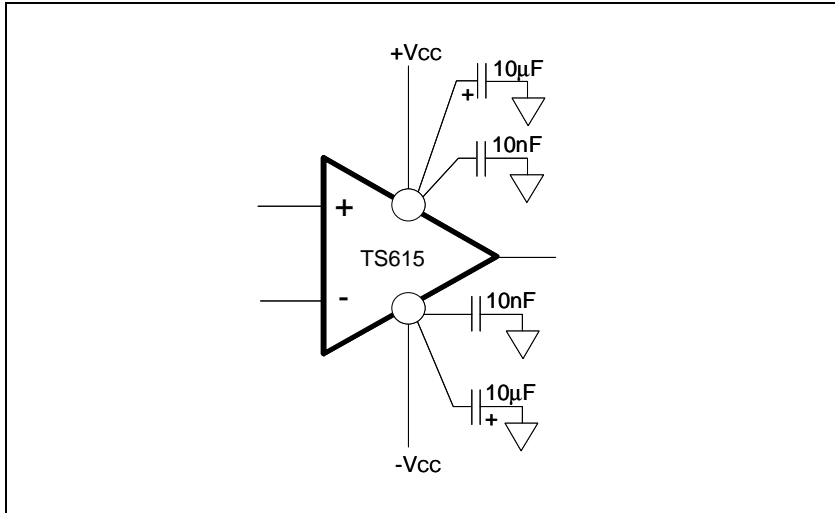

8.1 Single power supply

The TS615 can operate with power supplies ranging from 12V to 5V. The power supply can either be single (12V or 5V referenced to ground), or dual (such as $\pm 6\text{V}$ and $\pm 2.5\text{V}$).

In the event that a single supply system is used, new biasing is necessary to assume a positive output dynamic range between 0V and $+V_{CC}$ supply rails. Considering the values of V_{OH} and V_{OL} , the amplifier will provide an output dynamic from +0.5V to 10.6V on 25Ω load for a 12V supply and from 0.45V to 3.8V on 10Ω load for a 5V supply.

The amplifier must be biased with a mid-supply (nominally $+V_{CC}/2$), in order to maintain the DC component of the signal at this value. Several options are possible to provide this bias supply, such as a virtual ground using an operational amplifier or a two-resistance divider (which is the cheapest solution). A high resistance value is required to limit the current consumption. On the other hand, the current must be high enough to bias the non-inverting input of the amplifier. If we consider this bias current ($30\mu\text{A}$ max.) as the 1% of the current through the resistance divider to keep a stable mid-supply, two resistances of $2.2\text{k}\Omega$ can be used in the case of a 12V power supply and two resistances of 820Ω can be used in the case of a 5V power supply.

The input provides a high-pass filter with a break frequency below 10Hz which is necessary to remove the original 0 volt DC component of the input signal, and to fix it at $+V_{CC}/2$.

Figure 64 shows a schematic of a 5V single power supply configuration

Figure 64. Circuit for +5V single supply

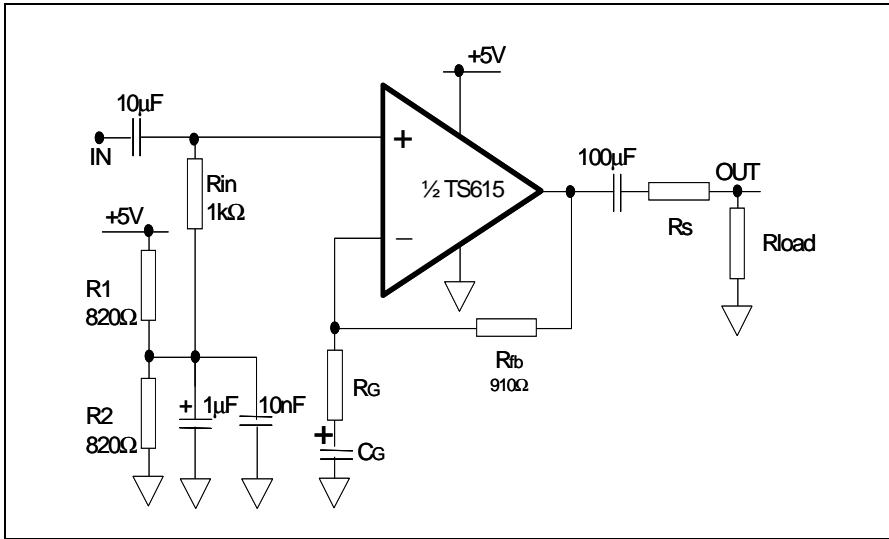

8.2 Channel separation and crosstalk

Figure 65 shows an example of crosstalk from one amplifier to a second amplifier. This phenomenon, accentuated at high frequencies, is unavoidable and intrinsic to the circuit itself.

Nevertheless, the PCB layout also has an effect on the crosstalk level. Capacitive coupling between signal wires, distance between critical signal nodes and power supply bypassing are the most significant factors.

Figure 65. Crosstalk vs. frequency: $A_v=+4$, $R_{fb}=620\Omega$, $V_{CC}=\pm 6V$, $V_{out}=2V_p$

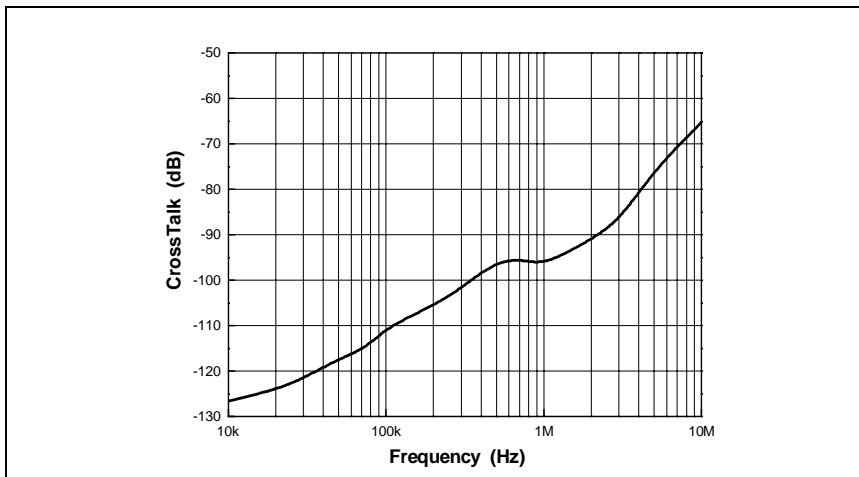

9 Power Down Mode Behavior

Please note that the short-circuited output in power-down mode is referenced to ($-V_{CC}$). No problems appear when used in differential mode. Nevertheless, when used in single-ended mode on a load referenced to GND, the ($-V_{CC}$) level contributes to a current consumption through the load.

Figure 66. Equivalent schematic

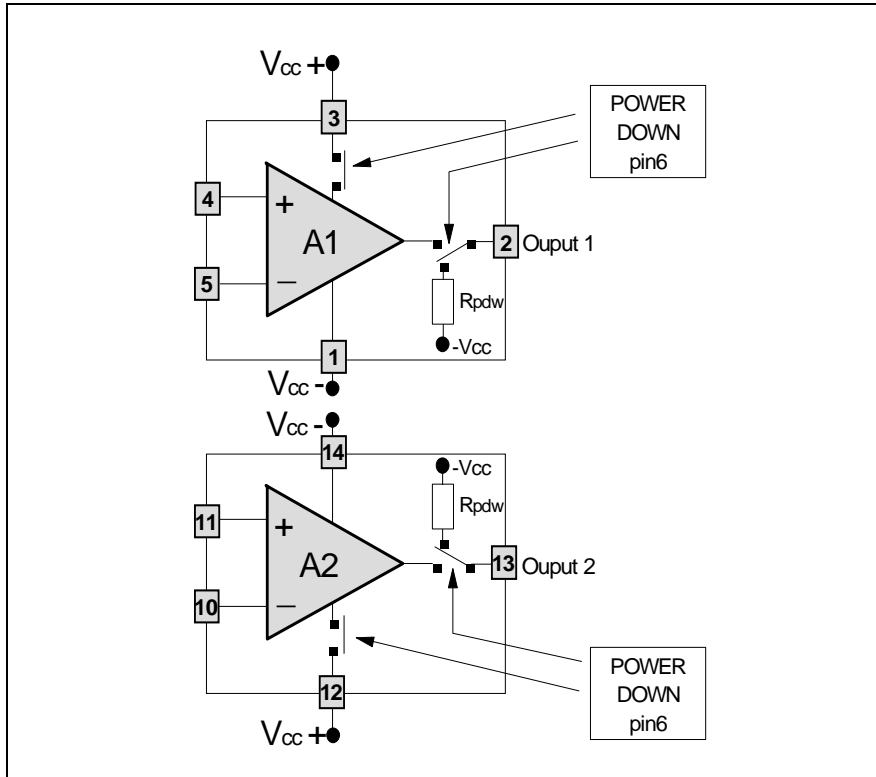

As shown in [Figure 66](#), the interest of having an output short-circuit in power-down mode is to keep the best impedance matching between the system and the twisted pair telephone line when the modem is in sleep mode. By doing this, the modem can be woken up with a signal from the line without any damage

to this signal. This concept is particularly intended for the ADSL-over-voice modems, where the modem in sleep mode, and must be woken up by the phone call.

Figure 67. Matching in sleep mode

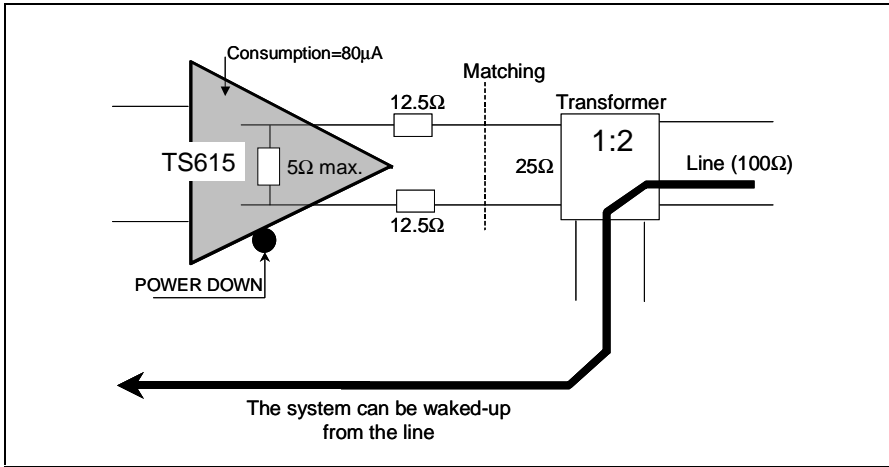

Figure 68. Standby mode. Time On>Off



Figure 69. Standby mode. Time Off>On

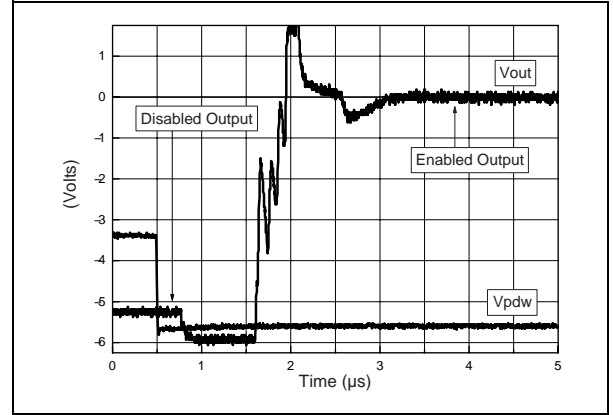
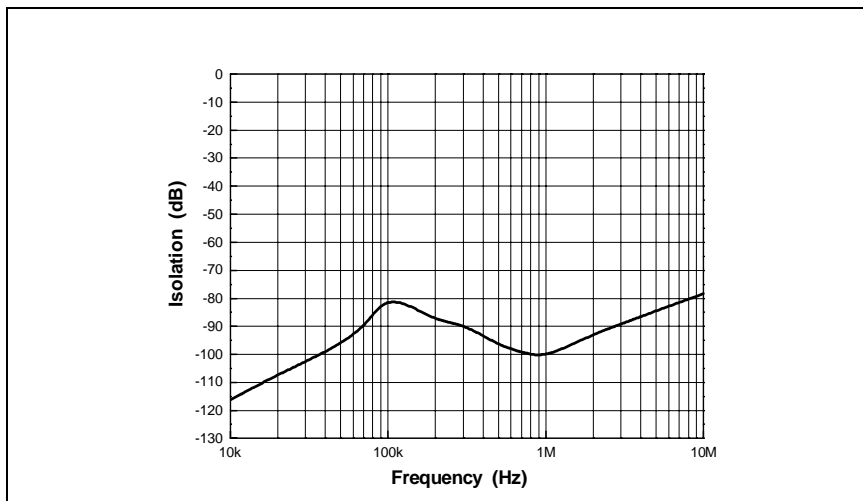

Figure 70. Standby mode. input/output isolation vs. frequency: $A_V=+4$, $R_{fb}=620\Omega$, $V_{CC}=\pm 6V$, $V_{out}=3V_p$



10 Choosing the Feedback Circuit

As described on [Figure 72](#) on page 31, the TS615 requires a 620 Ω feedback resistor to optimize the bandwidth with a gain of 12 dB for a 12 V power supply. Nevertheless, due to production test constraints, the TS615 is tested with the same feedback resistor for 12 V and 5 V power supplies (910 Ω).

Table 6. Closed-loop gain - feedback components

V _{CC} (V)	Gain	R _{fb} (Ω)
± 6	+1	750
	+2	680
	+4	620
	+8	510
	-1	680
	-2	680
	-4	620
	-8	510
± 2.5	+1	1.1k
	+2	1k
	+4	910
	+8	680
	-1	1k
	-2	1k
	-4	910
	-8	680

10.1 The bias of an inverting amplifier

A resistance is necessary to achieve a good input biasing, such as resistance R, shown in [Figure 71](#).

The magnitude of this resistance is calculated by assuming the negative and positive input bias current. The aim is to compensate for the offset bias current, which could affect the input offset voltage and the output DC component. Assuming I_{b-}, I_{b+}, R_{in}, R_{fb} and a zero volt output, the resistance R will be:

$$R = R_{in} // R_{fb}$$

Figure 71. Compensation of the input bias current

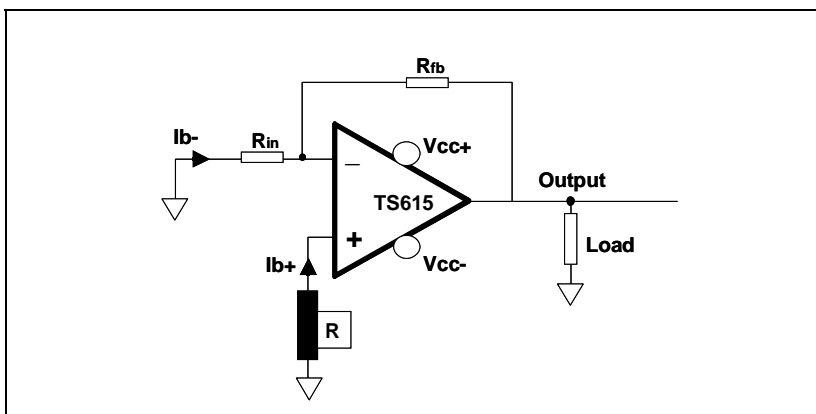

10.2 Active filtering

Figure 72. Low-pass active filtering. Sallen-Key

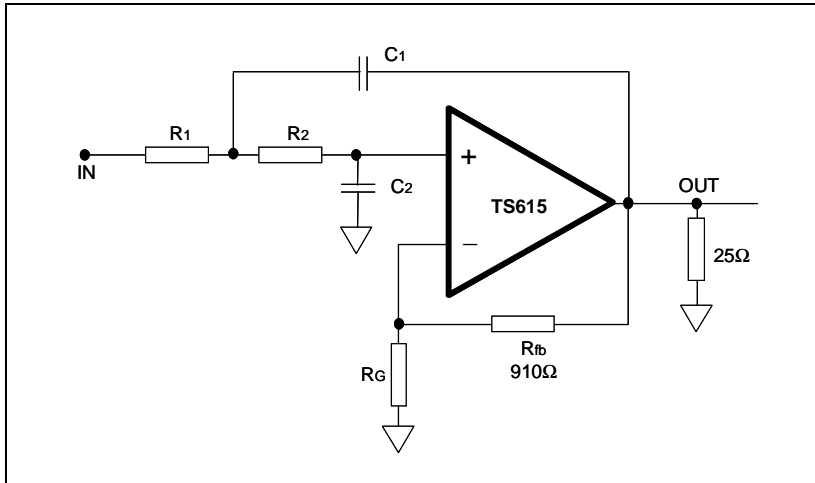

From the resistors R_{fb} and R_g we can directly calculate the gain of the filter in a classical, non-inverting amplification configuration:

$$A_V = g = 1 + \frac{R_{fb}}{R_g}$$

We assume the following expression as the response of the system:

$$T_{j\omega} = \frac{V_{out,j\omega}}{V_{in,j\omega}} = \frac{g}{1 + 2\zeta \frac{j\omega}{\omega_c} + \frac{(j\omega)^2}{\omega_c^2}}$$

The cutoff frequency is not gain-dependent and so becomes:

$$\omega_c = \frac{1}{\sqrt{R_1 R_2 C_1 C_2}}$$

The damping factor is calculated by the following expression:

$$\zeta = \frac{1}{2} \omega_c (C_1 R_1 + C_1 R_2 + C_2 R_1 - C_1 R_1 g)$$

The higher the gain the more sensitive the damping factor is. When the gain is higher than 1, it is preferable to use some very stable resistor and capacitor values. In the case of $R_1=R_2$:

$$\zeta = \frac{2C_2 - C_1 \frac{R_{fb}}{R_g}}{2\sqrt{C_1 C_2}}$$

11 Increasing the Line Level Using Active Impedance Matching

With passive matching, the output signal amplitude of the driver must be twice the amplitude on the load. To go beyond this limitation an active matching impedance can be used. With this technique, it is possible to maintain good impedance matching with an amplitude on the load higher than half of the output driver amplitude. This concept is shown in [Figure 73](#) for a differential line.

Figure 73. TS615 as a differential line driver with active impedance matching

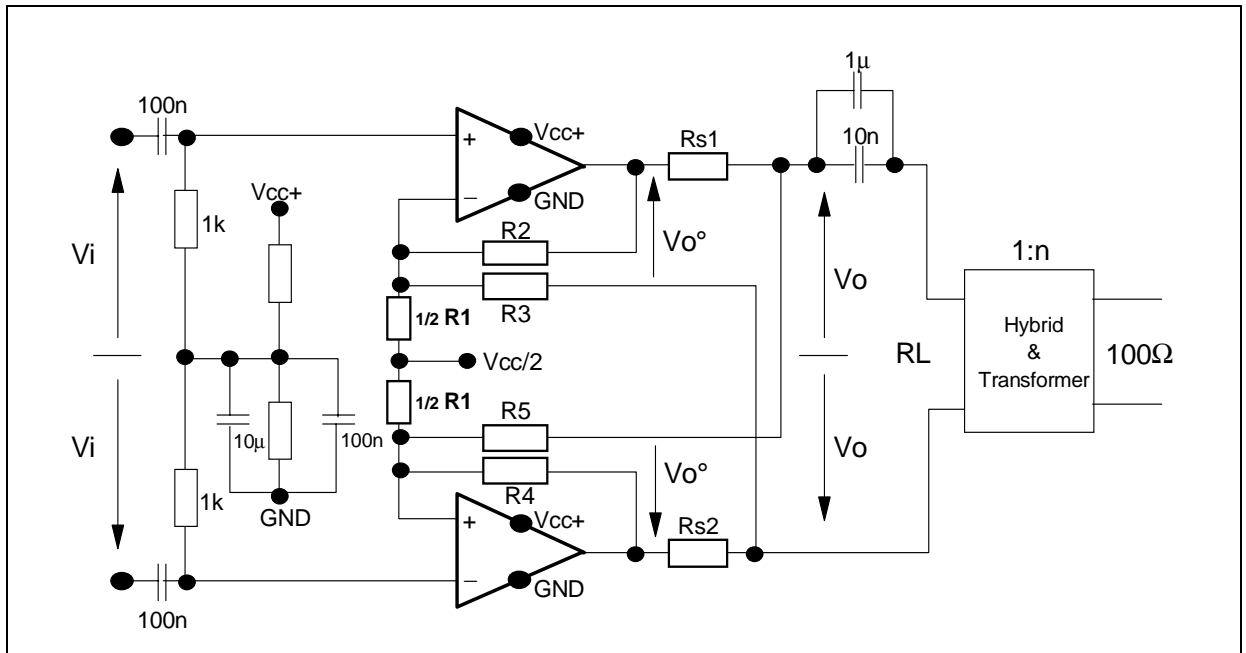

Component calculation

Let us consider the equivalent circuit for a single-ended configuration, as shown in [Figure 74](#).

Figure 74. Single-ended equivalent circuit

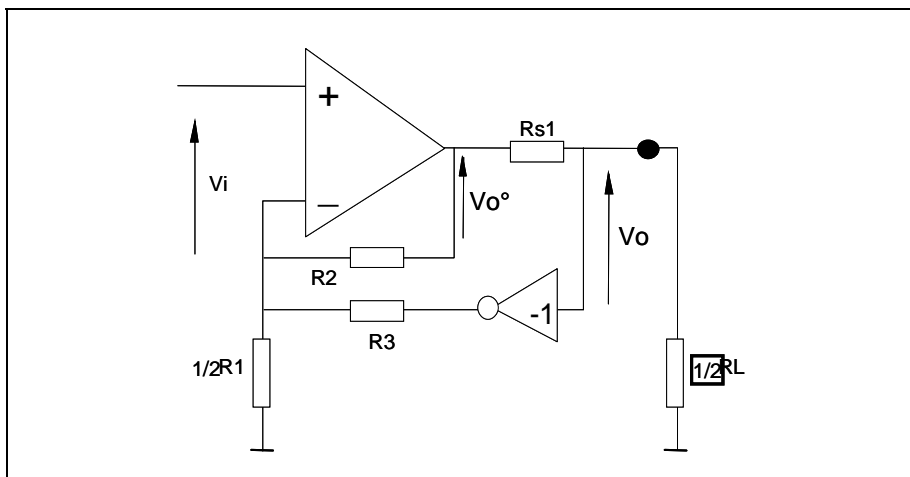

First let's consider the unloaded system. We can assume that the currents through R1, R2 and R3 are respectively:

$$\frac{2V_i}{R_1}, \frac{(V_i - V_o^\circ)}{R_2} \text{ and } \frac{(V_i + V_o)}{R_3}$$

As V_o° equals V_o without load, the gain in this case becomes:

$$G = \frac{V_o(\text{no load})}{V_i} = \frac{1 + \frac{2R_2}{R_1} + \frac{R_2}{R_3}}{1 - \frac{R_2}{R_3}}$$

The gain, for the loaded system is given by [Equation 6](#):

$$G_L = \frac{V_o(\text{with load})}{V_i} = \frac{1}{2} \frac{1 + \frac{2R_2}{R_1} + \frac{R_2}{R_3}}{1 - \frac{R_2}{R_3}} \tag{Equation 6}$$

The system shown in [Figure 74](#) is an ideal generator with a synthesized impedance acting as the internal impedance of the system. From this, the output voltage becomes:

$$V_o = (V_i G) - (R_o \cdot I_{out}) \tag{Equation 7}$$

where R_o is the synthesized impedance and I_{out} the output current.

On the other hand V_o can be expressed as:

$$V_o = \frac{V_i \left(1 + \frac{2R_2}{R_1} + \frac{R_2}{R_3} \right)}{1 - \frac{R_2}{R_3}} - \frac{R_{s1} I_{out}}{1 - \frac{R_2}{R_3}} \tag{Equation 8}$$

By identification of both [Equation 7](#) and [Equation 8](#), the synthesized impedance is, with $R_{s1}=R_{s2}=R_s$:

$$R_o = \frac{R_s}{1 - \frac{R_2}{R_3}} \tag{Equation 9}$$

Figure 75: Equivalent schematic. R_o is the synthesized impedance

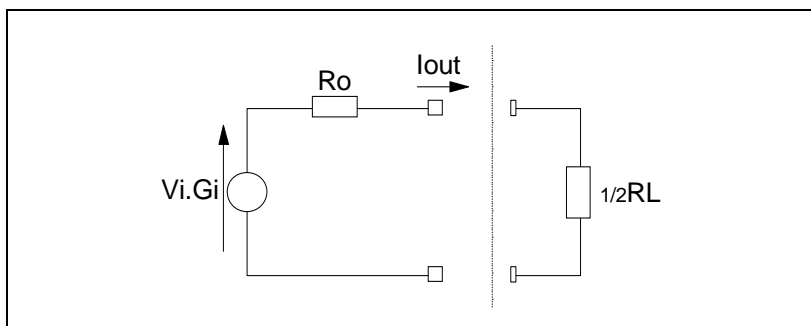

Let us write $V_o = kV_o$, where k is the matching factor varying between 1 and 2. If we assume that the current through R_3 is negligible, we can calculate the output resistance, R_o :

$$R_o = \frac{kV_o R_L}{R_L + 2R_{s1}}$$

After choosing the k factor, R_s will equal to $1/2R_L(k-1)$.

For a good impedance matching we assume that:

$$R_o = \frac{1}{2}R_L \tag{Equation 10}$$

From [Equation 9](#) and [Equation 10](#), we derive:

$$\frac{R_2}{R_3} = 1 - \frac{2R_s}{R_L} \tag{Equation 11}$$

By fixing an arbitrary value of R_2 , [Equation 11](#) becomes:

$$R_3 = \frac{R_2}{1 - \frac{2R_s}{R_L}}$$

Finally, the values of R_2 and R_3 allow us to extract R_1 from [Equation 6](#), so that:

$$R_1 = \frac{2R_2}{2\left(1 - \frac{R_2}{R_3}\right)G_L - 1 - \frac{R_2}{R_3}} \tag{Equation 12}$$

with G_L the required gain.

Table 7. Components calculation for impedance matching implementation

GL (gain for the loaded system)	GL is fixed for the application requirements $G_L = V_o/V_i = 0.5(1 + 2R_2/R_1 + R_2/R_3)/(1 - R_2/R_3)$
R1	$2R_2/[2(1 - R_2/R_3)G_L - 1 - R_2/R_3]$
R2 (=R4)	Arbitrarily fixed
R3 (=R5)	$R_2/(1 - R_s/0.5R_L)$
Rs	$0.5R_L(k-1)$
Load viewed by each driver	$kR_L/2$

12 Package Mechanical Data

TSSOP14 EXPOSED PAD MECHANICAL DATA

DIM.	mm.			inch		
	MIN.	TYP	MAX.	MIN.	TYP.	MAX.
A			1.2			0.047
A1			0.15		0.004	0.006
A2	0.8	1	1.05	0.031	0.039	0.041
b	0.19		0.30	0.007		0.012
c	0.09		0.20	0.004		0.0089
D	4.9	5	5.1	0.193	0.197	0.201
D1	1.7			0.067		
E	6.2	6.4	6.6	0.244	0.252	0.260
E1	4.3	4.4	4.5	0.169	0.173	0.177
E2	1.5			0.059		
e		0.65			0.0256	
K	0°		8°	0°		8°
L	0.45	0.60	0.75	0.018	0.024	0.030

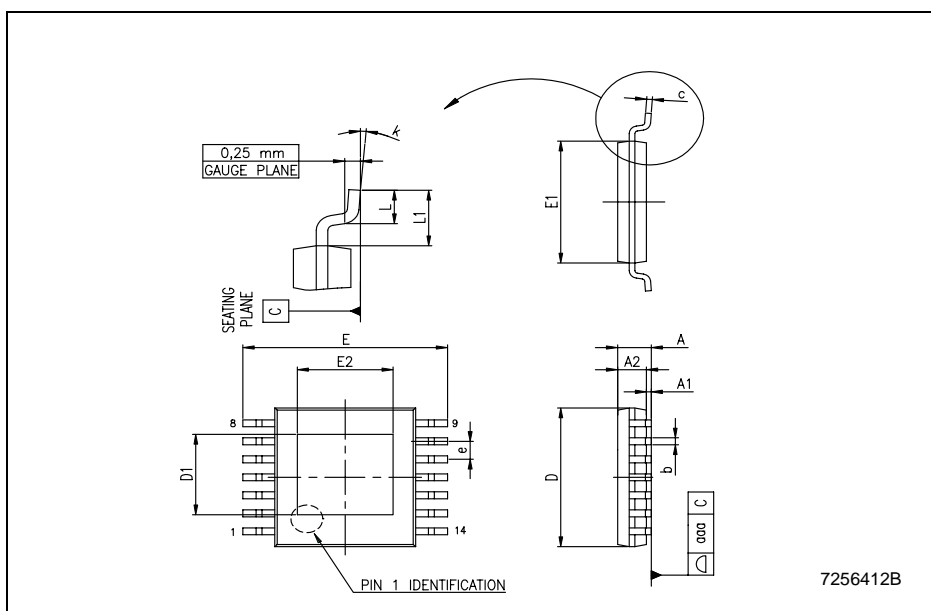

13 Revision History

Date	Revision	Description of Changes
01 Nov 2002	1	First Release
03 Dec 2004	2	General grammatical and formatting changes to entire document. Specific changes: <ul style="list-style-type: none"> • Moved note in Table 3 to Chapter 10: Choosing the Feedback Circuit on page 30. • Added Chapter 4: Safe Operating Area on page 16. • Simplified mathematical representations of the intermodulation product in Chapter 5: Intermodulation Distortion Product on page 17. • In Chapter 6: Printed Circuit Board Layout Considerations on page 20, change from “The copper area <i>can</i> be connected to (-Vcc) available on pin 4.” to “The copper area must be connected to -Vcc available on pin 4.”. • In Section 10.1: The bias of an inverting amplifier on page 30, change of section title, and correction of referred figure to Figure 71.

Information furnished is believed to be accurate and reliable. However, STMicroelectronics assumes no responsibility for the consequences of use of such information nor for any infringement of patents or other rights of third parties which may result from its use. No license is granted by implication or otherwise under any patent or patent rights of STMicroelectronics. Specifications mentioned in this publication are subject to change without notice. This publication supersedes and replaces all information previously supplied. STMicroelectronics products are not authorized for use as critical components in life support devices or systems without express written approval of STMicroelectronics.

The ST logo is a registered trademark of STMicroelectronics
 All other names are the property of their respective owners

© 2004 STMicroelectronics - All rights reserved

STMicroelectronics group of companies

Australia - Belgium - Brazil - Canada - China - Czech Republic - Finland - France - Germany - Hong Kong - India - Israel - Italy - Japan - Malaysia - Malta - Morocco - Singapore - Spain - Sweden - Switzerland - United Kingdom - United States of America

www.st.com