

2 x 4" 100W AC-DC Power Supplies

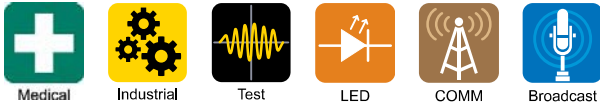

The compact CUS100ME is packaged in the industry standard 2x4" footprint. The series can deliver 100W convection cooled at 50°C or up to 75W at 85°C with forced air. Conduction cooled, the CUS100M can deliver 100W at 70°C and 50W at 80°C. With Medical & ITE certifications, the unit can be used in both Class I & Class II (no ground wire) applications, and meets Class B Conducted and Radiated EMI. Enclosure options include a baseplate, U channel or U channel with a cover.

Features

- Up to 100W Utilizing Convection or Conduction Cooling
- Operation in Ambient Temperatures of up to 85°C
- Medical Certifications (2 x MOPP)
- Class B Conducted and Radiated EMI
- Suitable for Class I and Class II installations
- Compact 2 x 4 x 1.24" Size
- Enclosure & Cooling Options

Benefits

- Quiet Operation
- Suitable for High Ambient Temperature Environments
- Suitable for B and BF Type Medical Equipment
- Easier System EMC Compliance
- Flexible Utilisation
- Space Saving in End Equipment
- Versatile Application

Model Selector

Model	Nominal Output Voltage (V)	Factory Set ⁽¹⁾ Output Voltage Capability (V)	Maximum Current Convection (A)	Maximum Power Convection (W)
CUS100ME-12	12	12 - 13.2	8.33	100
CUS100ME-15	15	15 - 16.5	6.66	100
CUS100ME-18	18	18 - 19.8	5.55	100
CUS100ME-24	24	24 - 26.4	4.16	100
CUS100ME-28	28	28 - 30.8	3.57	100
CUS100ME-36	36	36 - 39.6	2.77	100
CUS100ME-48	48	48 - 50	2.08	100

CUS100ME-	12	/	U	E	M
Output voltage 12, 15, 18, 24, 28, 36, 48			blank open frame U U channel A U channel with cover B baseplate	blank dual fuses E ⁽²⁾ single input fuse in line	blank JST connectors M ⁽²⁾ Molex connectors

Examples: CUS100ME-24/UEM, CUS100ME-12V5/A

Specifications		
Model		CUS150M
Input		
Input Voltage range	V	85 - 264Vac (3)
Input Frequency	Hz	47 - 63Hz (4)
Input Current (100Vac)	A	1.4
Inrush Current at 230Vac (typ) (Cold Start)	A	<65A
Leakage Current	uA	<250uA at 230Vac 63Hz
Touch Current (Enclosure Leakage)	uA	<100uA
Power Factor (115/230Vac)	-	>0.97 / 0.89 (100% load)
Harmonic Compliance	-	Meets IEC61000-3-2 Class A
No Load Power Consumption	W	<0.5W (230Vac)
Hold Up Time (typ) at 115Vac Input	ms	>24ms
Efficiency	-	Up to 94%
Average Efficiency	-	>87%. Measured at 25%, 50%, 75% and 100% load conditions
Conducted & Radiated EMI	-	EN55032/EN55011-B (See application notes for conditions)
Immunity	-	Compliant with EN60601-1-2:2015 (Ed4), see immunity table
Insulation Class	-	Construction suitable for Class I or Class II installation
Safety Agency Certifications	-	IEC/EN/UL60950-1 and 60601-1. ES60601-1. IEC/EN/UL62368-1 Designed to meet IEC61010-1. EN60335-1 Compliant versions available (2). CE Mark (LVD, EMC and RoHS)

Immunity				
Test	Standard	Test Level	Criteria	Notes
ESD	EN61000-4-2	4	A	-
Radiated Susceptibility	EN61000-4-3	3	A	Includes proximity field requirements of EN60601-1-2:2015
Electrical Fast Transient Burst	EN61000-4-4	4	A	(AC Port, 5kHz and 100kHz)
Surge	EN61000-4-5	3	A	-
Conducted Susceptibility	EN61000-4-6	3	A	-
Magnetic fields	EN61000-4-8	4	A	-
Voltage Dips and Input Interruptions	EN61000-4-11 Class 3 Industrial, incl EN55024 (100Vac)	0% for 1/2 cycle	A	-
		0% for 1 cycle	A	-
		40% for 10/12 cycles	A	-
		70% for 25/30 cycles	A	-
		80% for 250/300 cycles	A	-
		0% for 250/300 cycles	B	-
	EN61000-4-11 Class 3 Industrial, incl EN55024 (240Vac)	0% for 1/2 cycle	A	-
		0% for 1 cycle	A	-
		40% for 10/12 cycles	A	-
		70% for 25/30 cycles	A	-
		80% for 250/300 cycles	A	-
		0% for 250/300 cycles	B	-
	EN60601-1-2:2015 (100Vac)	0% for 1/2 cycle	A	-
		0% for 1 cycle	A	-
		70% for 25/30 cycles	A	-
		0% for 250/300 cycles	B	-
EN60601-1-2:2015 (240Vac)	0% for 1/2 cycle	A	-	
	0% for 1 cycle	A	-	
	70% for 25/30 cycles	A	-	
	0% for 250/300 cycles	B	-	
Ringwave Test	EN61000-4-12	3	A	-
Voltage Fluctuations	EN61000-4-14	Class 3	A	-
SEMI F47 Line Dip	SEMI F47	-	-	At input voltages > 200Vac

Specifications		
Model		CUS400M
Output		
Line Regulation	%	<0.5% (90 - 264VAC)
Load Regulation	%	<1% (0 - 100% load)
Ripple & Noise	%	<1% of nominal output for operating temperatures above 0°C At -20°C: 12V model <4%, 15V & 18V model <3%, other models <2%
Temperature Coefficient	%/°C	±0.02%/°C
Minimum Load	-	No minimum load required
Overcurrent Protection	%	110 to 190%. Hiccup mode, automatic recovery
Overvoltage Protection	-	115-140% of standard output voltage for each model, 48V model max 60V. Latching (unit shutdown), cycle AC input to reset
Remote Sense	-	None
Fan Supply	-	None
Parallel Operation	-	Not possible
Series Operation	-	Possible, see installation manual
Environmental		
Operating Temperature	°C	-20°C to +85°C, see derating curves below for operation above +50°C
Storage Temperature	°C	-40°C to +85°C
Operating Humidity (non condensing)	%RH	5 - 95%RH
Cooling	-	Convection, conduction or forced air cooling. See derating curves below
Altitude	m	5,000m. Operating, transportation and storage
Withstand Voltage (For 1 minute)	Vac	Input to Ground 1.5kVAC (1xMOPP), Input to Output 4kVAC (2xMOPP), Output to Ground 1.5kVAC (1xMOPP)
Isolation Resistance	MΩ	>100MΩ at 25°C, 70%RH & 500VDC
Vibration (Operating)	-	2G, 10-500Hz for 1 hour
Shock	-	30G, 11ms half sine
Other		
Weight (Typ)	g	Open Frame: 180g; /U: 240g; /A: 255g; /B: 220g
Size (WxLxH)	mm	Open frame version: 50.8 x 101.6 x 31.5
Size (WxLxH)	Inches	Open frame version: 2 x 4 x 1.24
Connectors	-	Input: JST B2P3-VH, Output: JST B6P-VH
Warranty	yrs	5

- Notes:
- See website for detailed specifications, test methods and installation manual.
Specification parameters apply at 25°C ambient temperature unless otherwise stated.
- (1) Output voltage is factory set and not user adjustable.
Non-standard output versions may be subject to minimum order quantities and variations to specification. For all non-standard output voltage settings please consult Sales.
 - (2) Subject to Minimum Order Quantities. Please contact Sales
 - (3) Derate linearly to 90% load from 90 to 85VAC input.
 - (4) For operation at 440Hz please consult Technical Sales.

Outline drawing CUS100ME (Open Frame unit)

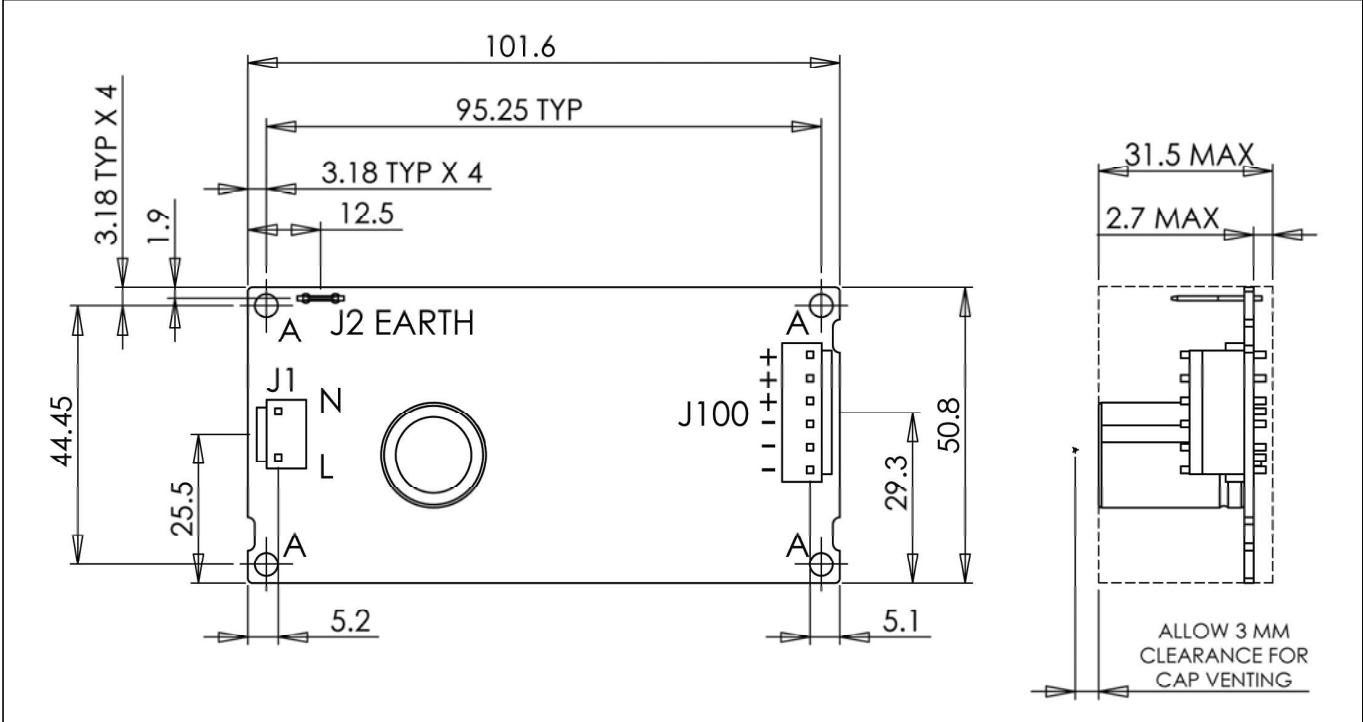

Outline drawing CUS100ME/U (U Channel) Option

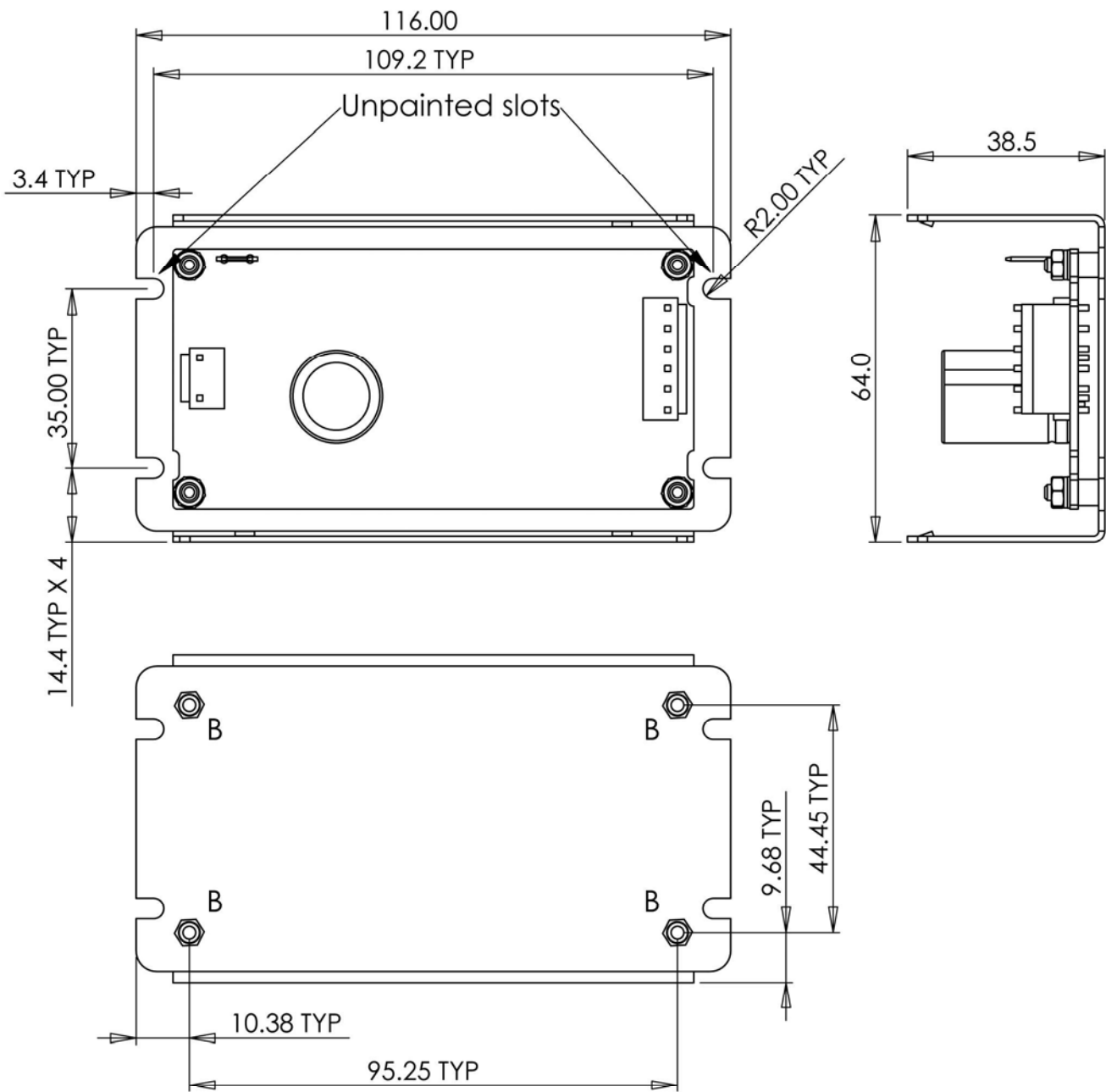

DIMENSION TOLERANCES: 0.00 ±0.2 0.0 ±0.4

NOTE: B - 4 OFF M3 FIXING - max thread penetration 4.25 mm

RECOMMENDED TORQUE - M3 - 0.5 - 0.6 Nm

Outline drawing CUS100ME/B (Baseplate) Option

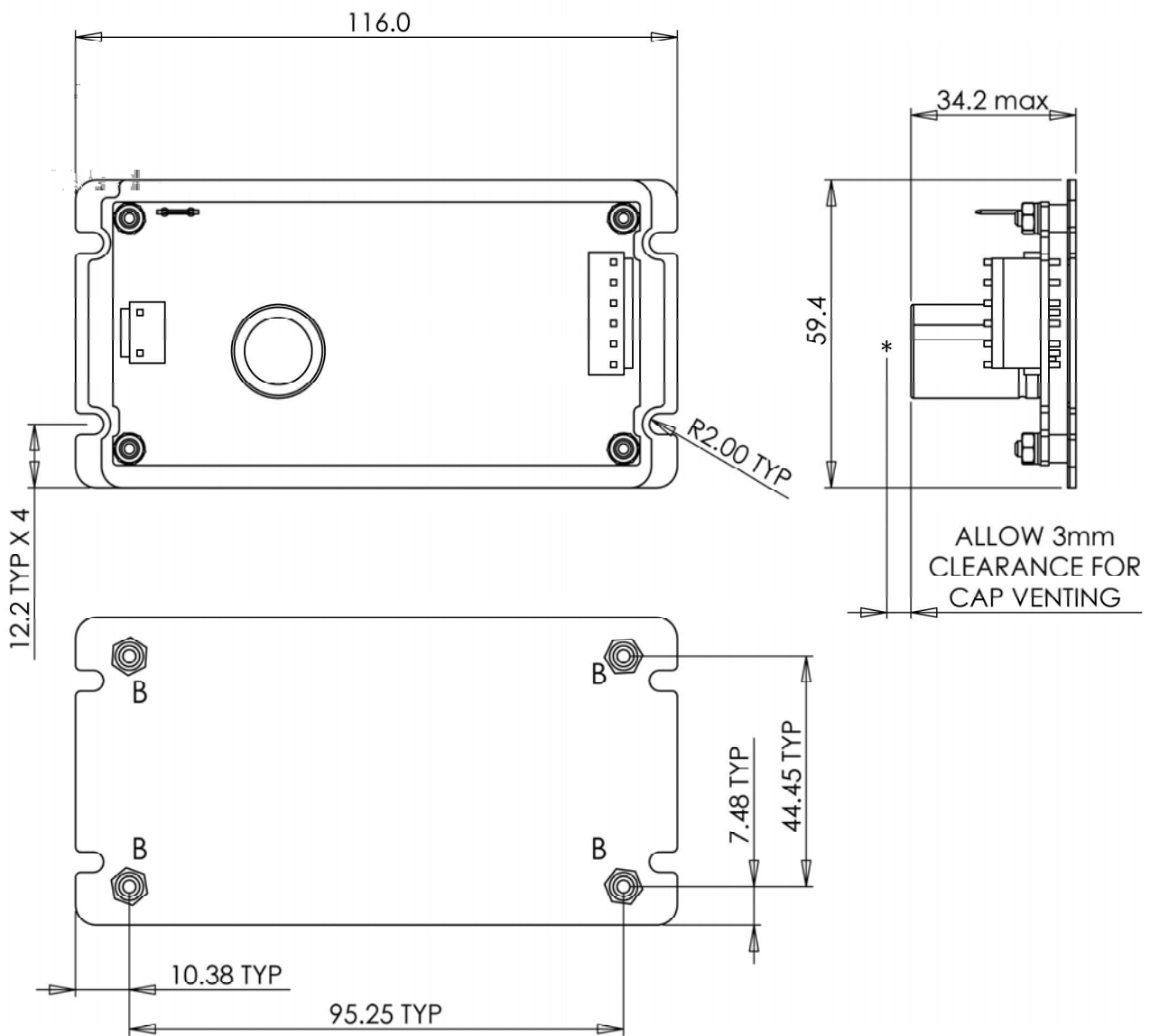

DIMENSION TOLERANCES: 0.00 ±0.2 0.0 ±0.4

NOTE: B - 4 OFF M3 FIXING - max thread penetration 4.25 mm

RECOMMENDED TORQUE - M3 - 0.5 - 0.6 Nm

Outline drawing CUS100ME/A (U Channel with cover) Option

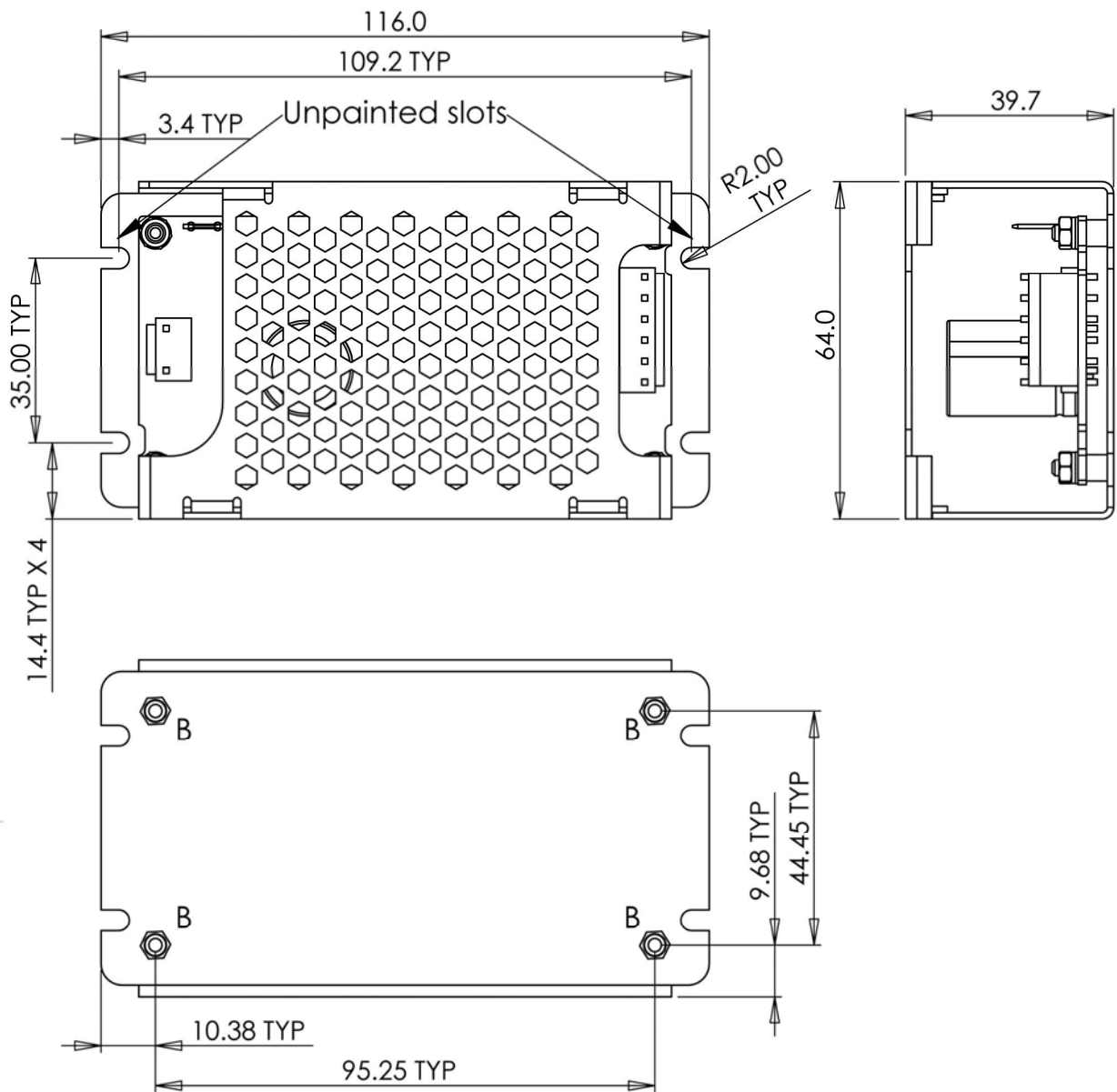

DIMENSION TOLERANCES: 0.00 ±0.2 0.0 ±0.4

NOTE: B - 4 OFF M3 FIXING - max thread penetration 4.25 mm

RECOMMENDED TORQUE - M3 - 0.5 - 0.6 Nm

Output Power vs Ambient Temperature (Convection/Conduction Cooled)

@ 90Vac to 264Vac, derate by 10% at 85Vac

- Open frame and /B convection cooling, Orientation A *1)
- /U - U chassis option, convection cooling *4)
- - /A - U chassis with top cover, convection cooling *4)
- /U and /B - U chassis and Baseplate option, cold plate cooling *5)
- - /A - U chassis with top cover, cold plate cooling *5)

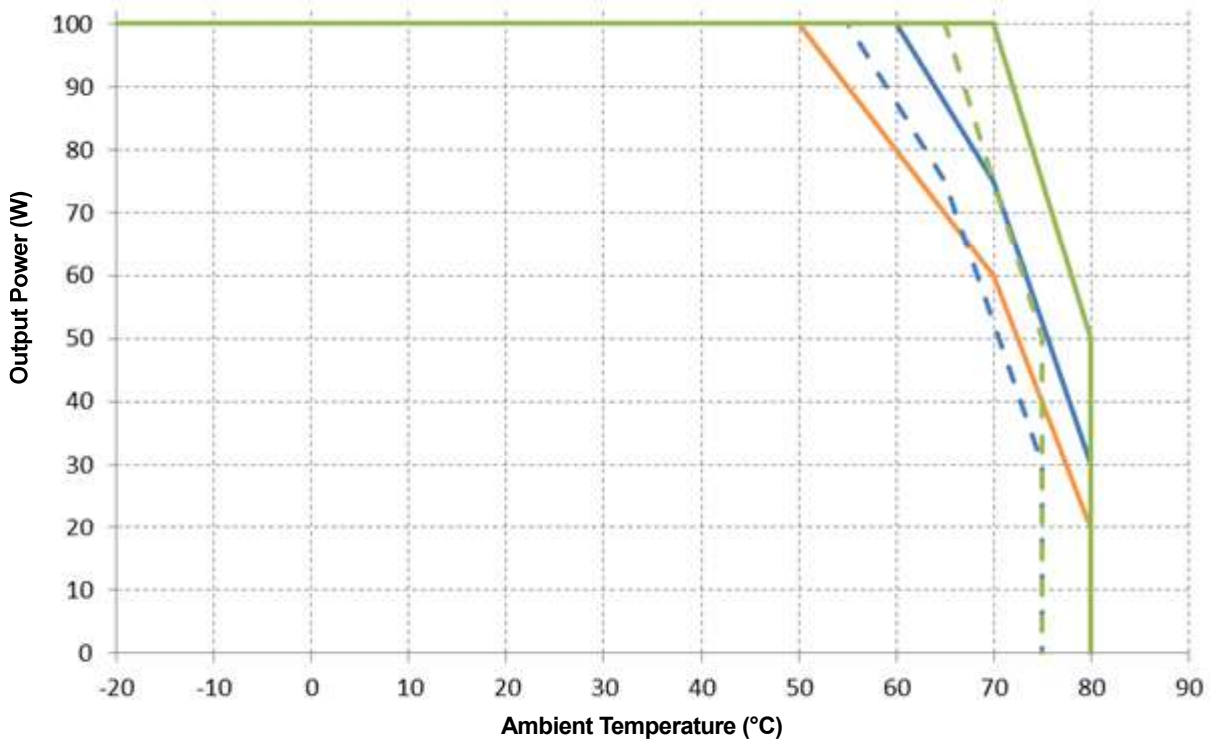

Output Power vs Ambient Temperature (Forced Air Cooled)

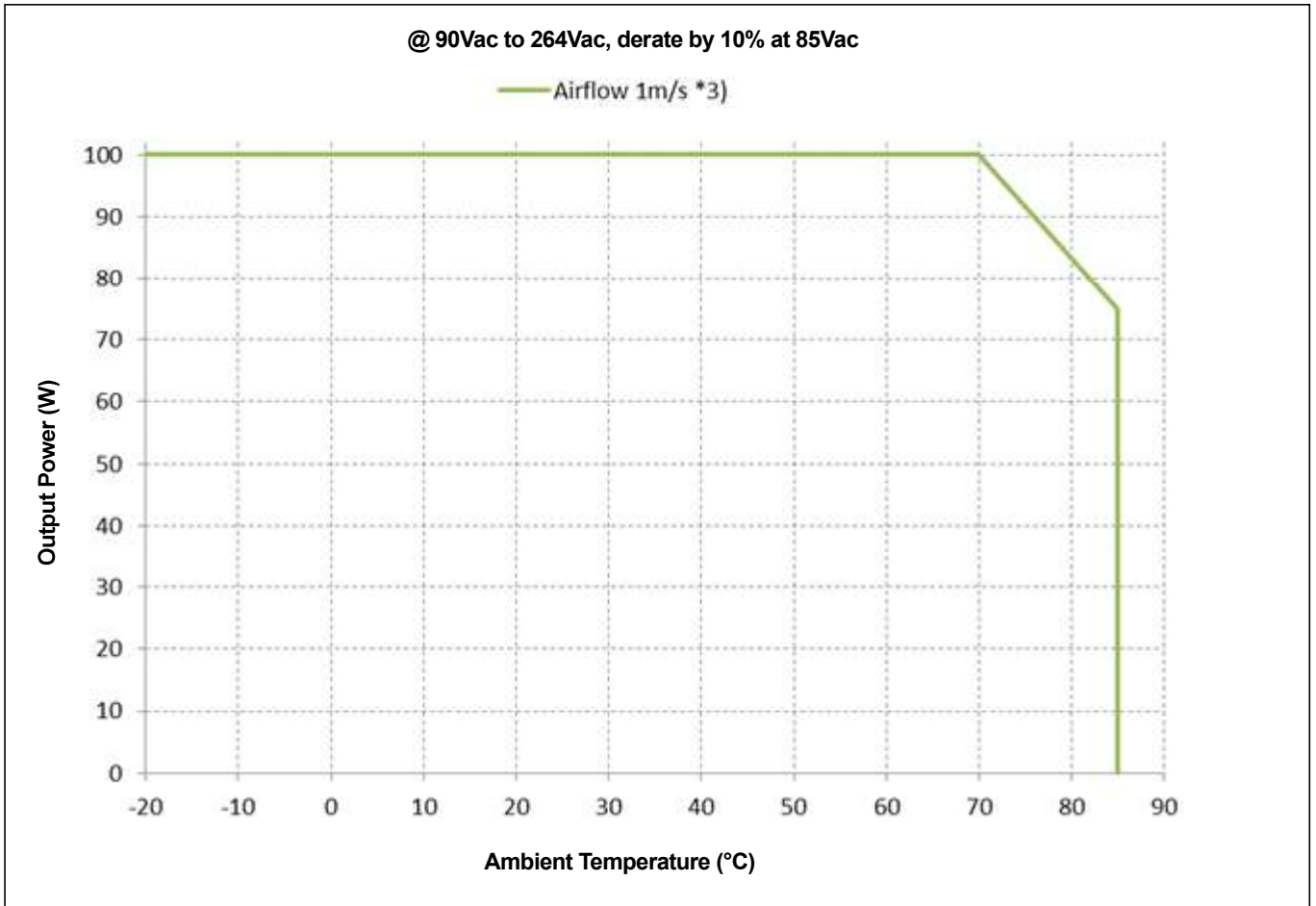

Notes:

- 1) 50mm above surface
 - 2) Not applicable
 - 3) Tested with airflow direction G (see Application Note)
 - 4) 50mm above surface, orientation A (see Application Note) no additional coldplate
 - 5) U chassis or Baseplate fixed on a coldplate (system chassis), orientation A (see Application Note)
- /B baseplate option performance is the same as with the U chassis option for coldplate cooling



TDK-Lambda France SAS

Tel: +33 1 60 12 71 65
france@fr.tdk-lambda.com
www.emea.lambda.tdk.com/fr



Italy Sales Office

Tel: +39 02 61 29 38 63
info.italia@it.tdk-lambda.com
www.emea.lambda.tdk.com/it



Netherlands

info@nl.tdk-lambda.com
www.emea.lambda.tdk.com/nl



TDK-Lambda Germany GmbH

Tel: +49 7841 666 0
info.germany@de.tdk-lambda.com
www.emea.lambda.tdk.com/de



Austria Sales Office

Tel: +43 2256 655 84
info@at.tdk-lambda.com
www.emea.lambda.tdk.com/at



Switzerland Sales Office

Tel: +41 44 850 53 53
info@ch.tdk-lambda.com
www.emea.lambda.tdk.com/ch



Nordic Sales Office

Tel: +45 8853 8086
info@dk.tdk-lambda.com
www.emea.lambda.tdk.com/dk



TDK-Lambda UK Ltd.

Tel: +44 (0) 12 71 85 66 66
powersolutions@uk.tdk-lambda.com
www.emea.lambda.tdk.com/uk



TDK-Lambda Ltd.

Tel: +9 723 902 4333
info@tdk-lambda.co.il
www.emea.lambda.tdk.com/il



C.I.S.

Commercial Support:

Tel: +7 (495) 665 2627

Technical Support:

Tel: +7 (812) 658 0463
info@tdk-lambda.ru
www.emea.lambda.tdk.com/ru



TDK-Lambda Americas

Tel: +1 800-LAMBDA-4 or 1-800-526-2324
powersolutions@us.tdk-lambda.com
www.us.lambda.tdk.com



TDK Electronics do Brasil Ltda

Tel: +55 11 3289-9599
sales.br@tdk-electronics.tdk.com
www.tdk-electronics.tdk.com/en



TDK-Lambda Corporation

Tel: +81-3-6778-1113
www.jp.lambda.tdk.com



TDK-Lambda (China) Electronics Co. Ltd.

Tel: +86 21 6485-0777
powersolutions@cn.tdk-lambda.com
www.lambda.tdk.com.cn



TDK-Lambda Singapore Pte Ltd.

Tel: +65 6251 7211
tfs.mkt@sg.tdk-lambda.com
www.sg.lambda.tdk.com



TDK India Private Limited, Power Supply Division

Tel: +91 80 4039-0660
mathew.philip@in.tdk-lambda.com
www.lambda.tdk.com

