

CNS series

Multifunction Time Delay Relay

- 8 programmable timing modes (4 on 8-pin models)
- 0.1 sec. to 100 min. programmable timing range
- Universal (24-240VAC/VDC) and fixed input types
- 10A output relay with DPDT contacts
- DIP switch selection of timing mode and range
- Knob and dial scale for setting actual delay time

File E22575

File LR15734

Users should thoroughly review the technical data before selecting a product part number. It is recommended that user also seek out the pertinent approvals files of the agencies/laboratories and review them to ensure the product meets the requirements for a given application.



Timing Modes

See the following page for a complete description of timing modes.

Timing Specifications

Timing Ranges: 0.1 to 1.0 / 1.0 to 10 / 10 to 100 sec.;
0.1 to 1.0 / 1.0 to 10 / 10 to 100 min.

Timing Adjustment: Knob adjustable within selected range.

Tolerance: -0, +20% of max. specified at high end of timing range; min. specified, or less, at low end.

Delta Time (for AC units add ±1 cycle 60 Hz.): ±10%.

Repeatability (Including first cycle of operation.): ±2% (for AC units add ±1 cycle 60 Hz.).

Reset Time (power interruption): 45 ms, typ.; 60 ms, max.

Minimum Pulse Width, Control: 50 ms.

Recycle Time: 45 ms, typ.; 60 ms, max.

Contact Data @ 25°C

Arrangements: 2 Form C (DPDT).

Material: Silver-cadmium oxide alloy.

Rating: 10 A @ 30VDC or 277VAC, resistive; 1/2 HP @ 250VAC; 1/3 HP @ 120VAC.

Expected Mechanical Life: 10 million operations.

Expected Electrical Life: 100,000 operations, min., at rated load.

Initial Dielectric Strength

Between Open Contacts: 1,000V rms, 60 Hz.

Between All Other Conductors: 1,500V rms, 60 Hz.

Ordering Information – Authorized distributors are more likely to stock boldface items listed below.

Universal Input Models

Input Voltage	Timing Functions	No. of Pins	Wiring Dia.	Part Number
24-240VAC/VDC	4	8	1	CNS-35-92
24-240VAC/VDC	8	11	2	CNS-35-96

Fixed Input Models

Input Voltage	Timing Functions	No. of Pins	Wiring Dia.	Part Number
120VAC	4	8	1	CNS-35-72
120VAC	8	11	2	CNS-35-76

Outline Dimensions

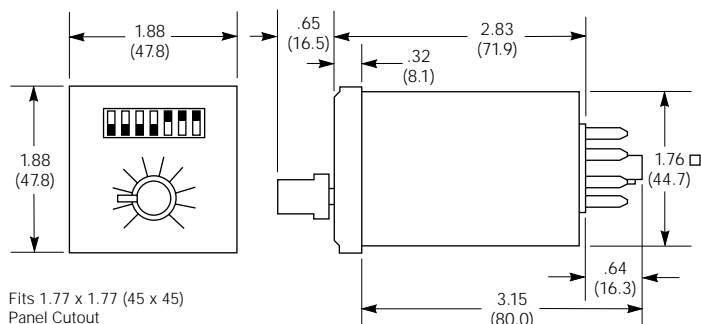

Dimensions are shown for reference purposes only.

Dimensions are in inches over (millimeters) unless otherwise specified.

Input Data @ 25°C

Voltage: Universal Input Type: 24 - 240V ±15%, 50/60 Hz. AC or DC.

Fixed Input Type: 120VAC ±15%, 50/60 Hz.

Power Requirement:

Universal Input Type: 10VA @ 240VAC; 5VA @ 120VAC; 1VA @ 24VAC.
10W @ 240VDC; 5W @ 120VDC; 1W @ 24VDC.

Fixed Input Type: 3VA @ 120VAC.

Transient Protection: Yes.

Reverse Voltage Protection: Yes.

Input Voltages and Limits @ 25°C

Input Type	Nominal Voltage	Minimum Voltage	Maximum Voltage
Universal	24-240VAC/VDC	20.4VAC/VDC	276VAC/VDC
Fixed	120VAC	102VAC	138VAC

Note: DC voltage must be filtered (5% p-p ripple max. at nom. voltage).
AC models will operate on 50 or 60 Hz.

Environmental Data

Temperature Range: Storage: -20°C to +70°C.

Operating: -10°C to +55°C.

Humidity: 85% relative humidity, non-condensing.

Mechanical Data

Termination: 8- or 11-pin octal style plug.

Enclosure: Beige plastic 1/16 DIN case. Dial scale provided for knob adjustment reference.

Sockets: Models with 8-pin base fit either 27E122 or 27E891 (snap-on) screw terminal sockets. 11-pin types fit either 27E123 or 27E892 (snap-on) screw terminal sockets.

Weight: 4.3 oz. (122g) approximately.

Accessory

Part Number	Name	Description
SSA-24C667	Mounting Clip	Ratchet-fit clip slides onto CNS from behind to secure CNS in panel mount applications.

Wiring Diagrams (Bottom Views)

(pins numbered clockwise from keyway)

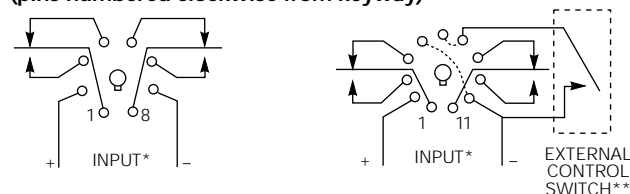

*** Note:** Input polarity for DC operation. For most reliable operation on AC, connect high side to "+" and low side to "-".

**** Important:** A dry circuit switch is recommended. A "dry circuit" switch is one rated to reliably switch currents of less than 50mA. Use of a switch rated for other than dry circuit may result in failure of the time delay relay to function properly.

The dotted lines shown between pins on 11-pin diagram indicate internal connections.

Specifications and availability subject to change.

www.tycoelectronics.com
Technical support:
Refer to inside back cover.

Mounting Clip Dimensions

SSA-24C667

Mounting Clip

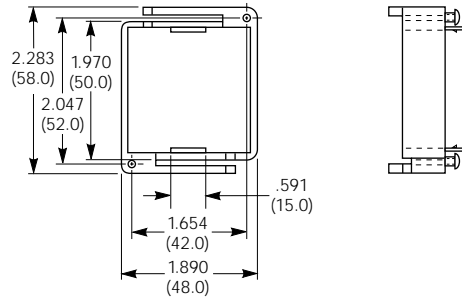

DIP Switch Layout

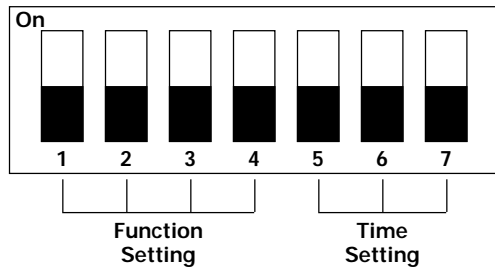

Note: The solid black blocks in the DIP switch diagrams indicate the switch positions. For example, all the switches are "off" in the diagram above.

Timing Range Switch Settings

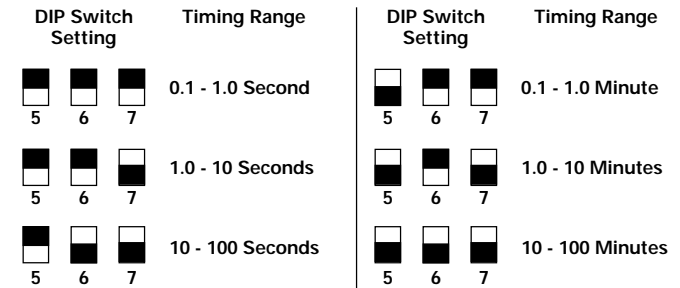

Timing Function Descriptions and Switch Settings

8 Or 11 Pin

Delay on Operate



72 & 92 - Output relay is energized at the completion of the time interval which is initiated by the application of input voltage.

76 & 96 - Same as the above except, closing the control switch after time out will de-energize the relay and reset the timer. Opening the switch will initiate another time interval. Closing the control switch during timing will reset the time to zero and inhibit timing until opened again.

Interval On (Input Controlled)



72 & 92 - Output relay is energized by the application of input voltage. The time interval is initiated at the same time with the relay de-energizing at the completion of the time interval.

76 & 96 - Same as above. Closing the control switch will have no effect on timing or the state of the relay.

Recycler (Initially Off)



72 & 92 - Output relay will begin cycling at a 50% duty cycle with the application of input power. The initial state of the relay will be de-energized.

76 & 96 - Same as the above except, closing the control switch will de-energize the relay and inhibit timing until it is once again opened, at which time it will start from zero time.

Recycler (Initially On)

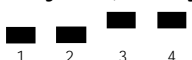

72 & 92 - Output relay will begin cycling at a 50% duty cycle with the application of input power. The initial state of the relay will be energized.

76 & 96 - Same as the above except, closing the control switch will energize the relay and inhibit timing until it is once again opened, at which time it will start from zero time.

Dimensions are shown for reference purposes only.

Dimensions are in inches over (millimeters) unless otherwise specified.

11 Pin Only

Delay on Release



76 & 96 - Output relay is energized by the closing of the control switch with the input applied or the application of input voltage with the control switch already closed. The time interval will be initiated by the opening of the control switch with the relay de-energizing at the completion of the time interval. Closing the control switch after time out will energize the relay in preparation for another time interval. Closing the control switch during timing will reset the time to zero and inhibit timing until opened again.

Inverted Delay on Release



72 & 92 - No Time Delay - Instantly On
76 & 96 - Output relay will energize with the application of the input voltage when the control switch is open. Control switch closing will de-energize the relay. A timing interval will be initiated with the opening of the control switch, at the completion of which the relay will energize. With the control switch closed upon application of input voltage, the relay will wait until the control switch is opened to initiate a time interval after which the relay will energize. Closing of the control switch during timing will reset the time to zero and inhibit timing until opened again.

Interval On (Switch Controlled)



76 & 96 - Output relay is energized by the application of input voltage with the control switch closed or the closing of the control switch with the input applied. Immediately upon either, timing is initiated with the relay de-energizing at the completion of the time interval. Closing the control switch after time out will reset the timer, energize the relay, and initiate another time interval. Closing the control switch during timing will have no effect on timing or the state of the relay.

Interval Off



76 & 96 - Output relay will initially be energized with the application of the input voltage when the control switch is open. Control switch closing will de-energize the relay and start a time interval. At the completion of the time interval, the relay will energize. With the control switch closed upon application of input voltage, a time interval will be initiated after which the relay will energize. Closing of the control switch during timing will have no effect on timing or the state of the relay.

Specifications and availability subject to change.

www.tycoelectronics.com
Technical support:
Refer to inside back cover.