

H-16C=RELAY, VACUUM, DPDT ✓ ACTIVE

Kilovac

TE Part # 1-1618273-5

TE Internal #: H-16C

[View on TE.com >](#)



Relays, Contactors & Switches > Relays > High Voltage Relays



Contact Voltage Rating: **12 kVDC**

Contact Arrangement: **2 Form C, DPDT**

High Voltage Connection (Coil): **Turret Terminals**

High Voltage Connection (Power): **Screw Terminals**

Economizer: **Without**

Features

Product Type Features

RF Rated	Yes
Product Type	Relay
Relay Type	High Voltage

Configuration Features

Economizer	Without
Power Switching	Yes

Electrical Characteristics

Contact Voltage Rating	12 kVDC
Voltage (Max)	26.5 VDC
Coil Voltage Rating	26.5 VDC
Coil Resistance	120 Ω
Contact Switching Voltage (Max)	12

Contact Features

Contact Arrangement	2 Form C, DPDT
Auxiliary Contacts	Without
Contact Current Rating	30 A

Termination Features

High Voltage Connection (Coil)	Turret Terminals
High Voltage Connection (Power)	Screw Terminals

Termination Style	Turret Terminals
-------------------	------------------

Mechanical Attachment

Mounting Type	Threaded
---------------	----------

Product Compliance

[For compliance documentation, visit the product page on TE.com>](#)

EU RoHS Directive 2011/65/EU	Not Compliant
EU ELV Directive 2000/53/EC	Not Compliant
China RoHS 2 Directive MIIT Order No 32, 2016	Restricted Materials Above Threshold
EU REACH Regulation (EC) No. 1907/2006	Current ECHA Candidate List: JAN 2019 (197) Candidate List Declared Against: JAN 2019 (197)
Halogen Content	Not Yet Reviewed for halogen content
Solder Process Capability	Not lead free process capable

Product Compliance Disclaimer

This information is provided based on reasonable inquiry of our suppliers and represents our current actual knowledge based on the information they provided. This information is subject to change. The part numbers that TE has identified as EU RoHS compliant have a maximum concentration of 0.1% by weight in homogenous materials for lead, hexavalent chromium, mercury, PBB, PBDE, DBP, BBP, DEHP, DIBP, and 0.01% for cadmium, or qualify for an exemption to these limits as defined in the Annexes of Directive 2011/65/EU (RoHS2). Finished electrical and electronic equipment products will be CE marked as required by Directive 2011/65/EU. Components may not be CE marked. Additionally, the part numbers that TE has identified as EU ELV compliant have a maximum concentration of 0.1% by weight in homogenous materials for lead, hexavalent chromium, and mercury, and 0.01% for cadmium, or qualify for an exemption to these limits as defined in the Annexes of Directive 2000/53/EC (ELV). Regarding the REACH Regulations, TE's information on SVHC in articles for this part number is still based on the European Chemical Agency (ECHA) 'Guidance on requirements for substances in articles' (Version: 2, April 2011), applying the 0.1% weight on weight concentration threshold at the finished product level. TE is aware of the European Court of Justice ruling of September 10th, 2015 also known as O5A (Once An Article Always An Article) stating that, in case of 'complex object', the threshold for a SVHC must be applied to both the product as a whole and simultaneously to each of the articles forming part of its composition. TE has evaluated this ruling based on the new ECHA "Guidance on requirements for substances in articles" (June 2017, version 4.0) and will be updating its statements accordingly.

Compatible Parts



TE Part # 1618273-2
H-14/115VDC=RELAY,
VACUUM, DPD



TE Part # 1-1618273-8
H-17/12VDC=RELAY,
VACUUM, SPDT



TE Part # 2-1618273-7
H-17C=RELAY, VACUUM,
SPDT



TE Part # 2-1618273-8
H-17C/115VDC=RELAY,
VACUUM, SP



TE Part # 1618273-3
H-14/12VDC=RELAY,
VACUUM, DPDT



TE Part # 1-1618273-7
H-17/115VDC=RELAY,
VACUUM, SPD



TE Part # 1618273-1
H-14=RELAY, VACUUM,
DPDT



TE Part # 7-1618273-1
H-8=RELAY, VACUUM,
SPDT



TE Part # 1618273-6
H-14C=RELAY, VACUUM,
SPDT

Customers Also Bought



TE Part #2-1393139-0
MDR-172-1=MDR



TE Part #1045747-1
1088 0000 02

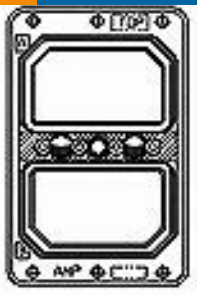

TE Part #207595-5
DUAL RECEPT W/JS

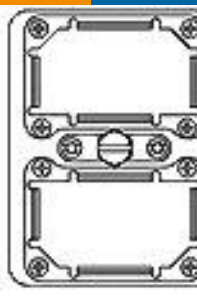

TE Part #207596-1
DUAL PLUG ASY W/MALE
JACKSCREW



TE Part #1-1423152-0
2112DH3NE=RLY,MINI,
ON,2P,HERM



TE Part #975264-000
MK-0001-30



TE Part #1-1616043-0
B140V=RELAY



TE Part #1-1616933-6
D7PH=RELAY



TE Part #1-1617787-4
FCB-405-0524L=M83536/5-
024L



TE Part #1-1393139-7
MDR-167-1=MDR

Documents



[Datasheets & Catalog Pages](#)

[5-1773450-5_sec7_H-14](#)

English