

Distributed by:

JAMECO[®]
ELECTRONICS

www.Jameco.com ♦ 1-800-831-4242

The content and copyrights of the attached
material are the property of its owner.

Jameco Part Number 2066054

ADC0816/ADC0817

8-Bit μ P Compatible A/D Converters with 16-Channel Multiplexer

General Description

The ADC0816, ADC0817 data acquisition component is a monolithic CMOS device with an 8-bit analog-to-digital converter, 16-channel multiplexer and microprocessor compatible control logic. The 8-bit A/D converter uses successive approximation as the conversion technique. The converter features a high impedance chopper stabilized comparator, a 256R voltage divider with analog switch tree and a successive approximation register. The 16-channel multiplexer can directly access any one of 16-single-ended analog signals, and provides the logic for additional channel expansion. Signal conditioning of any analog input signal is eased by direct access to the multiplexer output, and to the input of the 8-bit A/D converter.

The device eliminates the need for external zero and full-scale adjustments. Easy interfacing to microprocessors is provided by the latched and decoded multiplexer address inputs and latched TTL TRI-STATE[®] outputs.

The design of the ADC0816, ADC0817 has been optimized by incorporating the most desirable aspects of several A/D conversion techniques. The ADC0816, ADC0817 offers high speed, high accuracy, minimal temperature dependence, excellent long-term accuracy and repeatability, and consumes minimal power. These features make this device ideally suited to applications from process and machine control to consumer and automotive applications. For similar performance in an 8-channel, 28-pin, 8-bit A/D converter, see the ADC0808, ADC0809 data sheet. (See AN-258 for more information.)

Features

- Easy interface to all microprocessors
- Operates ratiometrically or with $5 V_{DC}$ or analog span adjusted voltage reference
- 16-channel multiplexer with latched control logic
- Outputs meet TTL voltage level specifications
- 0V to 5V analog input voltage range with single 5V supply
- No zero or full-scale adjust required
- Standard hermetic or molded 40-pin DIP package
- Temperature range -40°C to $+85^{\circ}\text{C}$ or -55°C to $+125^{\circ}\text{C}$
- Latched TRI-STATE output
- Direct access to "comparator in" and "multiplexer out" for signal conditioning
- ADC0816 equivalent to MM74C948
- ADC0817 equivalent to MM74C948-1

Key Specifications

- | | |
|--------------------------|--------------------------------------|
| ■ Resolution | 8 Bits |
| ■ Total Unadjusted Error | $\pm\frac{1}{2}$ LSB and ± 1 LSB |
| ■ Single Supply | $5 V_{DC}$ |
| ■ Low Power | 15 mW |
| ■ Conversion Time | 100 μs |

Block Diagram

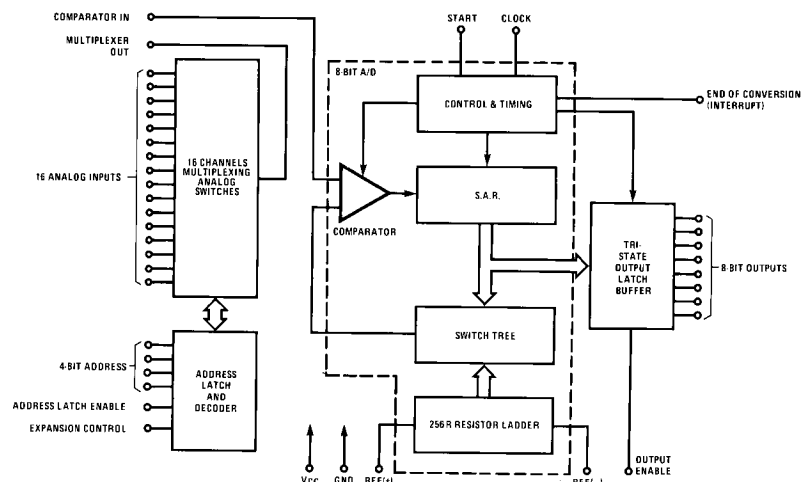

527701

TRI-STATE[®] is a trademark of National Semiconductor Corporation.

Connection Diagram

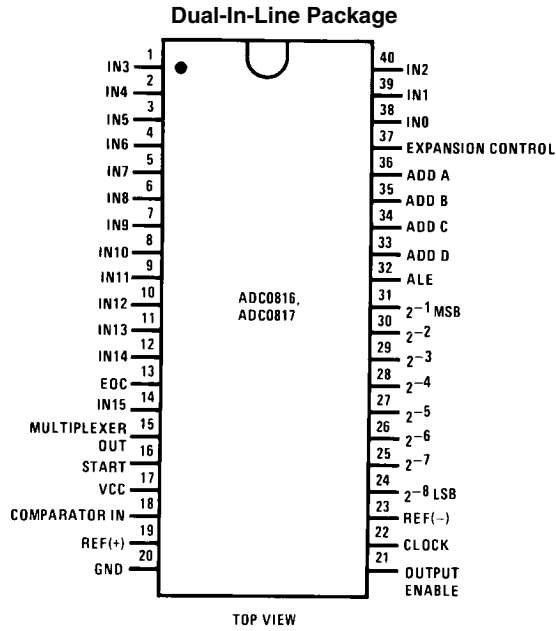

527706

Order Number ADC0816CCN or ADC0817CCN
See NS Package Number N40A

Ordering Information

TEMPERATURE RANGE		-40°C to +85°C	
Error	±½ Bit Unadjusted	ADC0816CCN	ADC0816CCJ *
	±1 Bit Unadjusted	ADC0817CCN	
Package Outline		N40A Molded DIP	J40A Hermetic DIP

* This product is obsolete in the Hermetic DIP.

Absolute Maximum Ratings (Notes 1, 2)

If Military/Aerospace specified devices are required, please contact the National Semiconductor Sales Office/Distributors for availability and specifications.

Supply Voltage (V_{CC}) (Note 3)	6.5V
Voltage at Any Pin	-0.3V to (V_{CC} +0.3V)
Except Control Inputs	
Voltage at Control Inputs (START, OE, CLOCK, ALE, EXPANSION CONTROL, ADD A, ADD B, ADD C, ADD D)	-0.3V to 15V
Storage Temperature Range	-65°C to + 150°C
Package Dissipation at $T_A = 25^\circ\text{C}$	875 mW
Lead Temp. (Soldering, 10 seconds)	
Dual-In-Line Package (Plastic)	260°C

Molded Chip Carrier Package	
Vapor Phase (60 seconds)	215°C
Infrared (15 seconds)	220°C
ESD Susceptibility (Note 9)	400V

Operating Conditions (Notes 1, 2)

Temperature Range (Note 1)	$T_{MIN} \leq T_A \leq T_{MAX}$
ADC0816CCN, ADC0817CCN	-40°C $\leq T_A \leq$ +85°C
Range of V_{CC} (Note 1)	4.5 V_{DC} to 6.0 V_{DC}
Voltage at Any Pin	0V to V_{CC}
Except Control Inputs	
Voltage at Control Inputs (START, OE, CLOCK, ALE, EXPANSION CONTROL, ADD A, ADD B, ADD C, ADD D)	0V to 15V

Electrical Characteristics

Converter Specifications: $V_{CC}=5$ $V_{DC}=V_{REF(+)}$, $V_{REF(-)}=GND$, $V_{IN}=V_{COMPARATOR\ IN}$, $T_{MIN} \leq T_{MAX}$ and $f_{CLK} = 640$ kHz unless otherwise stated.

Symbol	Parameter	Conditions	Min	Typ	Max	Units
	ADC0816					
	Total Unadjusted Error (Note 5)	25°C T_{MIN} to T_{MAX}			$\pm\frac{1}{2}$ $\pm\frac{3}{4}$	LSB LSB
	ADC0817					
	Total Unadjusted Error (Note 5)	0°C to 70°C T_{MIN} to T_{MAX}			± 1 $\pm 1\frac{1}{4}$	LSB LSB
	Input Resistance	From Ref(+) to Ref(-)	1.0	4.5		k Ω
	Analog Input Voltage Range	(Note 4) V(+) or V(-)	GND - 0.1		$V_{CC} + 0.1$	V_{DC}
$V_{REF(+)}$	Voltage, Top of Ladder	Measured at Ref(+)		V_{CC}	$V_{CC}+0.1$	V
$\frac{V_{REF(+)} + V_{REF(-)}}{2}$	Voltage, Center of Ladder		$V_{CC}/2 - 0.1$	$V_{CC}/2$	$V_{CC}/2 + 0.1$	V
$V_{REF(-)}$	Voltage, Bottom of Ladder	Measured at Ref(-)	-0.1	0		V
	Comparator Input Current	$f_c=640$ kHz, (Note 6)	-2	± 0.5	2	μA

Electrical Characteristics

Digital Levels and DC Specifications: ADC0816CCN, ADC0817CCN—4.75V $\leq V_{CC} \leq$ 5.25V, -40°C $\leq T_A \leq$ +85°C unless otherwise noted.

Symbol	Parameter	Conditions	Min	Typ	Max	Units
ANALOG MULTIPLEXER						
R_{ON}	Analog Multiplexer ON Resistance	(Any Selected Channel) $T_A=25^\circ\text{C}$, $R_L=10\text{k}$ $T_A=85^\circ\text{C}$ $T_A=125^\circ\text{C}$		1.5	3 6 9	k Ω k Ω k Ω
ΔR_{ON}	Δ ON Resistance Between Any 2 Channels	(Any Selected Channel) $R_L=10\text{k}$		75		Ω
I_{OFF+}	OFF Channel Leakage Current	$V_{CC}=5\text{V}$, $V_{IN}=5\text{V}$, $T_A=25^\circ\text{C}$ T_{MIN} to T_{MAX}		10	200 1.0	nA μA
$I_{OFF(-)}$	OFF Channel Leakage Current	$V_{CC}=5\text{V}$, $V_{IN}=0$, $T_A=25^\circ\text{C}$ T_{MIN} to T_{MAX}	-200 -1.0			nA μA

Symbol	Parameter	Conditions	Min	Typ	Max	Units
CONTROL INPUTS						
$V_{IN(1)}$	Logical "1" Input Voltage		$V_{CC} - 1.5$			V
$V_{IN(0)}$	Logical "0" Input Voltage				1.5	V
$I_{IN(1)}$	Logical "1" Input Current (The Control Inputs)	$V_{IN}=15V$			1.0	μA
$I_{IN(0)}$	Logical "0" Input Current (The Control Inputs)	$V_{IN}=0$	-1.0			μA
I_{CC}	Supply Current	$f_{CLK}=640\text{ kHz}$		0.3	3.0	mA
DATA OUTPUTS AND EOC (INTERRUPT)						
$V_{OUT(1)}$	Logical "1" Output Voltage	$I_O=-360\ \mu A, T_A=85^\circ C$ $I_O=-300\ \mu A, T_A=125^\circ C$	$V_{CC} - 0.4$			V
$V_{OUT(0)}$	Logical "0" Output Voltage	$I_O=1.6\text{ mA}$			0.45	V
$V_{OUT(0)}$	Logical "0" Output Voltage EOC	$I_O=1.2\text{ mA}$			0.45	V
I_{OUT}	TRI-STATE Output Current	$V_O=V_{CC}$ $V_O=0$	-3.0		3.0	μA μA

Electrical Characteristics

Timing Specifications: $V_{CC}=V_{REF(+)}=5V$, $V_{REF(-)}=GND$, $t_r=t_f=20\text{ ns}$ and $T_A=25^\circ C$ unless otherwise noted.

Symbol	Parameter	Conditions	Min	Typ	Max	Units
t_{WS}	Minimum Start Pulse Width	(Figure 5) (Note 7)		100	200	ns
t_{WALE}	Minimum ALE Pulse Width	(Figure 5)		100	200	ns
t_s	Minimum Address Set-Up Time	(Figure 5)		25	50	ns
T_H	Minimum Address Hold Time	(Figure 5)		25	50	ns
t_D	Analog MUX Delay Time from ALE	$R_S=0\ \Omega$ (Figure 5)		1	2.5	μs
t_{H1}, t_{H0}	OE Control to Q Logic State	$C_L=50\text{ pF}, R_L=10k$ (Figure 8)		125	250	ns
t_{1H}, t_{0H}	OE Control to Hi-Z	$C_L=10\text{ pF}, R_L=10k$ (Figure 8)		125	250	ns
t_c	Conversion Time	$f_c=640\text{ kHz}$, (Figure 5) (Note 8)	90	100	116	μs
f_c	Clock Frequency		10	640	1280	kHz
t_{EOC}	EOC Delay Time	(Figure 5)	0		$8 + 2\ \mu s$	Clock Periods
C_{IN}	Input Capacitance	At Control Inputs		10	15	pF
C_{OUT}	TRI-STATE Output Capacitance	At TRI-STATE Outputs (Note 8)		10	15	pF

Note 1: Absolute Maximum Ratings indicate limits beyond which damage to the device may occur. DC and AC electrical specifications do not apply when operating the device beyond its specified operating conditions.

Note 2: All voltages are measured with respect to GND, unless otherwise specified.

Note 3: A Zener diode exists, internally, from V_{CC} to GND and has a typical breakdown voltage of $7 V_{DC}$.

Note 4: Two on-chip diodes are tied to each analog input which will forward conduct for analog input voltages one diode drop below ground or one diode drop greater than the V_{CC} supply. The spec allows 100 mV forward bias of either diode. This means that as long as the analog V_{IN} does not exceed the supply voltage by more than 100 mV, the output code will be correct. To achieve an absolute 0 V_{DC} to 5 V_{DC} input voltage range will therefore require a minimum supply voltage of $4.900 V_{DC}$ over temperature variations, initial tolerance and loading.

Note 5: Total unadjusted error includes offset, full-scale, and linearity errors. See Figure 3. None of these A/Ds requires a zero or full-scale adjust. However, if an all zero code is desired for an analog input other than 0.0V, or if a narrow full-scale span exists (for example: 0.5V to 4.5V full-scale) the reference voltages can be adjusted to achieve this. See Figure 13.

Note 6: Comparator input current is a bias current into or out of the chopper stabilized comparator. The bias current varies directly with clock frequency and has little temperature dependence (Figure 6). See paragraph 4.0.

Note 7: If start pulse is asynchronous with converter clock or if $f_c > 640\text{ kHz}$, the minimum start pulse width is 8 clock periods plus $2\ \mu s$. For synchronous operation at $f_c \leq 640\text{ kHz}$ take start high within 100 ns of clock going low.

Note 8: The outputs of the data register are updated one clock cycle before the rising edge of EOC.

Note 9: Human body model, 100 pF discharged through a 1.5 k Ω resistor.

Functional Description

Multiplexer: The device contains a 16-channel single-ended analog signal multiplexer. A particular input channel is selected by using the address decoder. *Table 1* shows the input states for the address line and the expansion control line to select any channel. The address is latched into the decoder on the low-to-high transition of the address latch enable signal.

TABLE 1.

Selected Analog Channel	Address Line				Expansion Control
	D	C	B	A	
IN0	L	L	L	L	H
IN1	L	L	L	H	H
IN2	L	L	H	L	H
IN3	L	L	H	H	H
IN4	L	H	L	L	H
IN5	L	H	L	H	H
IN6	L	H	H	L	H
IN7	L	H	H	H	H
IN8	H	L	L	L	H
IN9	H	L	L	H	H
IN10	H	L	H	L	H
IN11	H	L	H	H	H
IN12	H	H	L	L	H
IN13	H	H	L	H	H
IN14	H	H	H	L	H
IN15	H	H	H	H	H
All Channels OFF	X	X	X	X	L

X=don't care

Additional single-ended analog signals can be multiplexed to the A/D converter by disabling all the multiplexer inputs using the expansion control. The additional external signals are connected to the comparator input and the device ground. Additional signal conditioning (i.e., prescaling, sample and hold, instrumentation amplification, etc.) may also be added between the analog input signal and the comparator input.

CONVERTER CHARACTERISTICS

The Converter

The heart of this single chip data acquisition system is its 8-bit analog-to-digital converter. The converter is designed to give fast, accurate, and repeatable conversions over a wide range of temperatures. The converter is partitioned into 3 major sections: the 256R ladder network, the successive approximation register, and the comparator. The converter's digital outputs are positive true.

The 256R ladder network approach *Figure 1* was chosen over the conventional R/2R ladder because of its inherent monotonicity, which guarantees no missing digital codes. Monotonicity is particularly important in closed loop feedback control systems. A non-monotonic relationship can cause oscillations that will be catastrophic for the system. Additionally, the 256R network does not cause load variations on the reference voltage.

The bottom resistor and the top resistor of the ladder network in *Figure 1* are not the same value as the remainder of the network. The difference in these resistors causes the output characteristic to be symmetrical with the zero and full-scale points of the transfer curve. The first output transition occurs when the analog signal has reached + 1/2 LSB and succeeding output transitions occur every 1 LSB later up to full-scale.

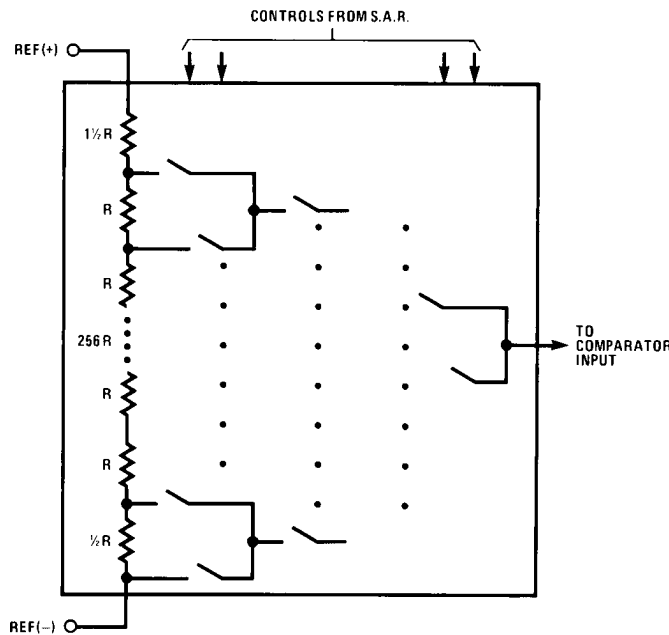

527702

FIGURE 1. Resistor Ladder and Switch Tree

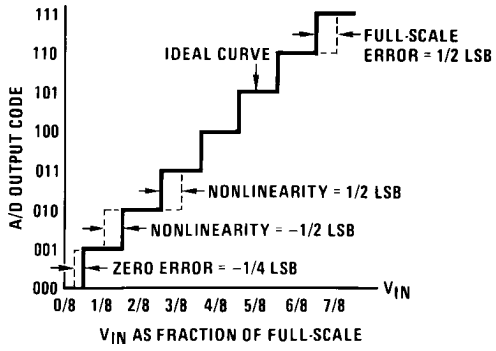

527703

FIGURE 2. 3-Bit A/D Transfer Curve

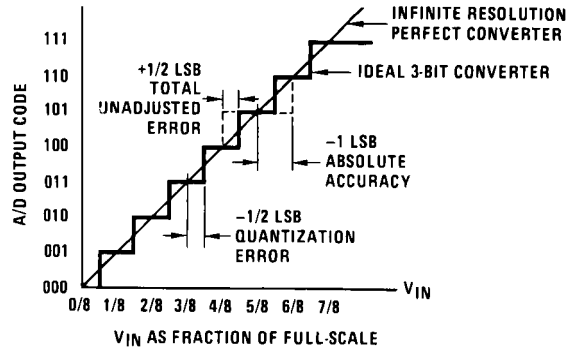

527704

FIGURE 3. 3-Bit A/D Absolute Accuracy Curve

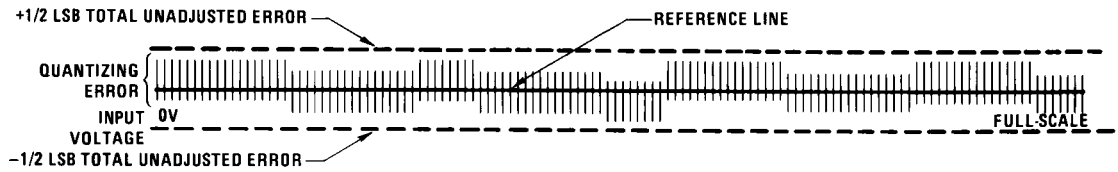

527705

FIGURE 4. Typical Error Curve

Timing Diagram

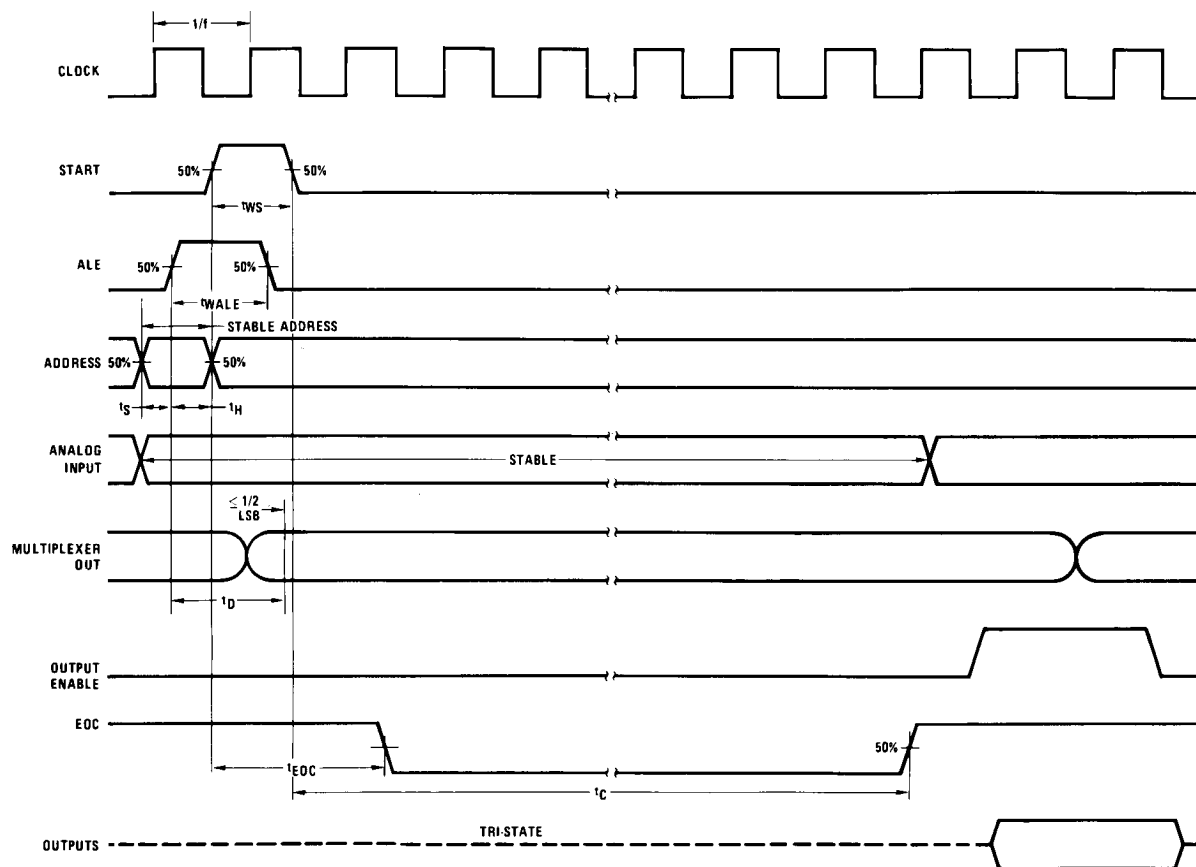

527707

FIGURE 5.

The successive approximation register (SAR) performs 8 iterations to approximate the input voltage. For any SAR type converter, n -iterations are required for an n -bit converter. *Figure 2* shows a typical example of a 3-bit converter. In the ADC0816, ADC0817, the approximation technique is extended to 8 bits using the 256R network.

The A/D converter's successive approximation register (SAR) is reset on the positive edge of the start conversion (SC) pulse. The conversion is begun on the falling edge of the start conversion pulse. A conversion in process will be interrupted by receipt of a new start conversion pulse. Continuous conversion may be accomplished by tying the end-of-conversion (EOC) output to the SC input. If used in this mode, an external start conversion pulse should be applied after power up. End-of-conversion will go low between 0 and 8 clock pulses after the rising edge of start conversion.

The most important section of the A/D converter is the comparator. It is this section which is responsible for the ultimate accuracy of the entire converter. It is also the comparator drift which has the greatest influence on the repeatability of the device. A chopper-stabilized comparator provides the most effective method of satisfying all the converter requirements.

The chopper-stabilized comparator converts the DC input signal into an AC signal. This signal is then fed through a high gain AC amplifier and has the DC level restored. This technique limits the drift component of the amplifier since the drift is a DC component which is not passed by the AC amplifier. This makes the entire A/D converter extremely insensitive to temperature, long term drift and input offset errors.

Figure 4 shows a typical error curve for the ADC0816 as measured using the procedures outlined in AN-179.

Typical Performance Characteristics

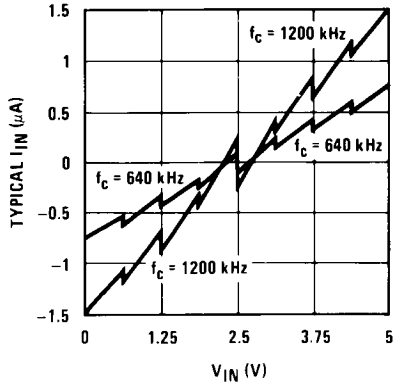

527718

FIGURE 6. Comparator I_{IN} vs. V_{IN}
($V_{CC}=V_{REF}=5V$)

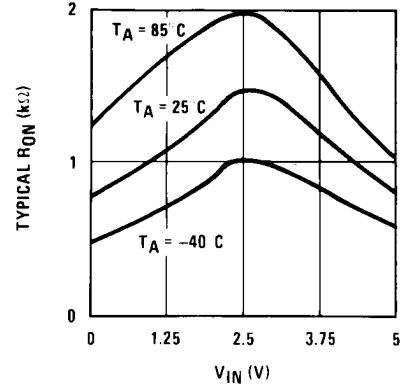

527719

FIGURE 7. Multiplexer R_{ON} vs. V_{IN}
($V_{CC}=V_{REF}=5V$)

TRI-STATE Test Circuits and Timing Diagrams

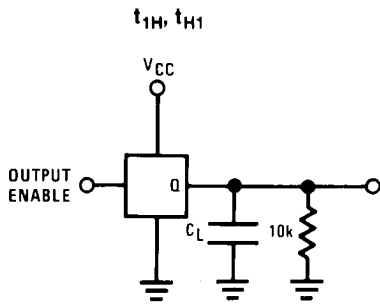

$t_{1H}, C_L = 10 \text{ pF}$

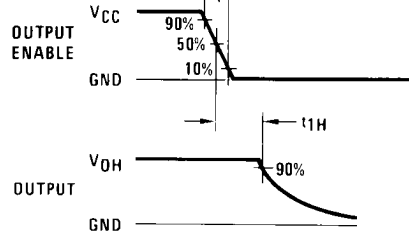

$t_{H1}, C_L = 50 \text{ pF}$

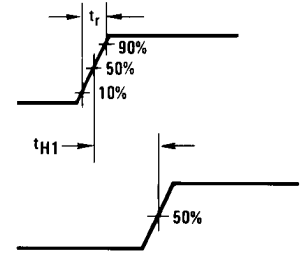

527709

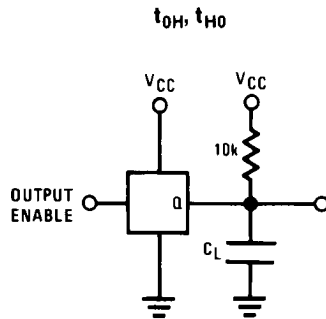

$t_{0H}, C_L = 10 \text{ pF}$

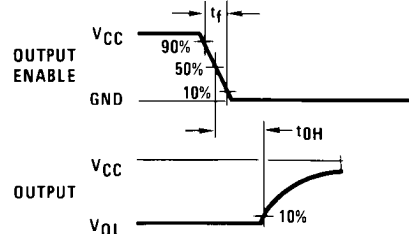

$t_{H0}, C_L = 50 \text{ pF}$

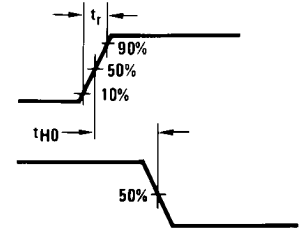

527710

FIGURE 8.

Applications Information

OPERATION

1.0 Ratiometric Conversion

The ADC0816, ADC0817 is designed as a complete Data Acquisition System (DAS) for ratiometric conversion systems. In ratiometric systems, the physical variable being measured is expressed as a percentage of full-scale which is not necessarily related to an absolute standard. The voltage input to the ADC0816 is expressed by the equation

$$\frac{V_{IN}}{V_{fs} - V_Z} = \frac{D_X}{D_{MAX} - D_{MIN}}$$

(1)

- V_{IN} = Input voltage into the ADC0816
- V_{fs} = Full-scale voltage
- V_Z = Zero voltage
- D_X = Data point being measured
- D_{MAX} = Maximum data limit
- D_{MIN} = Minimum data limit

A good example of a ratiometric transducer is a potentiometer used as a position sensor. The position of the wiper is directly proportional to the output voltage which is a ratio of the full-scale voltage across it. Since the data is represented as a proportion of full-scale, reference requirements are greatly reduced, eliminating a large source of error and cost for many applications. A major advantage of the ADC0816, ADC0817 is that the input voltage range is equal to the supply range so the transducers can be connected directly across the supply

and their outputs connected directly into the multiplexer inputs, (Figure 9).

Ratiometric transducers such as potentiometers, strain gauges, thermistor bridges, pressure transducers, etc., are suitable for measuring proportional relationships; however, many types of measurements must be referred to an absolute standard such as voltage or current. This means a system reference must be used which relates the full-scale voltage to the standard volt. For example, if $V_{CC} = V_{REF} = 5.12V$, then the full-scale range is divided into 256 standard steps. The smallest standard step is 1 LSB which is then 20 mV.

2.0 Resistor Ladder Limitations

The voltages from the resistor ladder are compared to the selected input 8 times in a conversion. These voltages are coupled to the comparator via an analog switch tree which is referenced to the supply. The voltages at the top, center and bottom of the ladder must be controlled to maintain proper operation.

The top of the ladder, Ref(+), should not be more positive than the supply, and the bottom of the ladder, Ref(-), should not be more negative than ground. The center of the ladder voltage must also be near the center of the supply because the analog switch tree changes from N-channel switches to P-channel switches. These limitations are automatically satisfied in ratiometric systems and can be easily met in ground referenced systems.

Figure 10 shows a ground referenced system with a separate supply and reference. In this system, the supply must be trimmed to match the reference voltage. For instance, if a 5.12V reference is used, the supply should be adjusted to the same voltage within 0.1V.

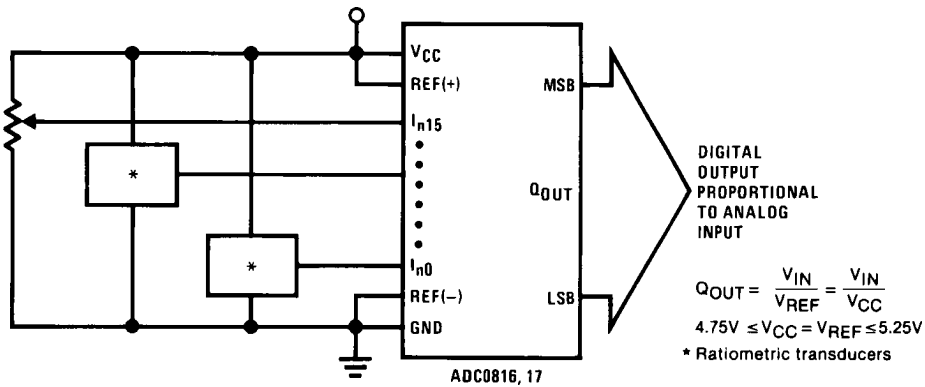
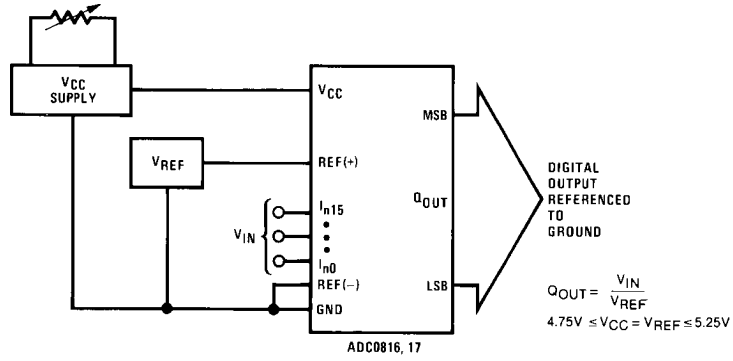

FIGURE 9. Ratiometric Conversion System

The ADC0816 needs less than a milliamp of supply current so developing the supply from the reference is readily accomplished. In Figure 11 a ground references system is shown which generates the supply from the reference. The buffer shown can be an op amp of sufficient drive to supply the milliamp of supply current and the desired bus drive, or if a capacitive bus is driven by the outputs a large capacitor will supply the transient supply current as seen in Figure 12. The LM301 is overcompensated to insure stability when loaded by the 10 μF output capacitor.

The top and bottom ladder voltages cannot exceed V_{CC} and ground, respectively, but they can be symmetrically less than V_{CC} and greater than ground. The center of the ladder voltage should always be near the center of the supply. The sensitivity of the converter can be increased, (i.e., size of the LSB steps decreased) by using a symmetrical reference system. In Figure 13, a 2.5V reference is symmetrically centered about $V_{CC}/2$ since the same current flows in identical resistors. This system with a 2.5V reference allows the LSB to be half the size of the LSB in a 5V reference system.



527712

FIGURE 10. Ground Referenced Conversion System Using Trimmed Supply

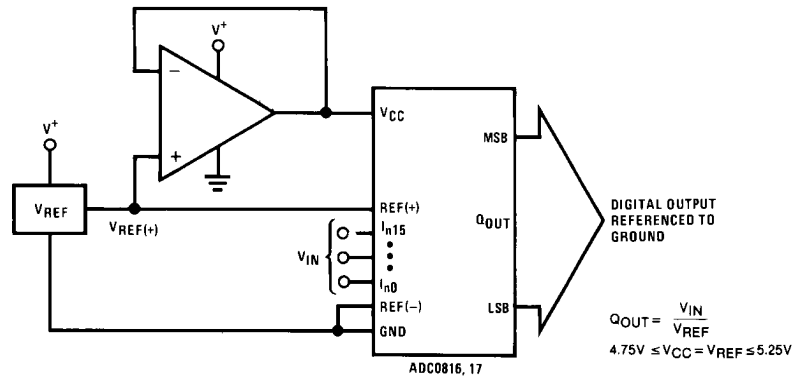

527713

FIGURE 11. Ground Referenced Conversion System with Reference Generating V_{CC} Supply

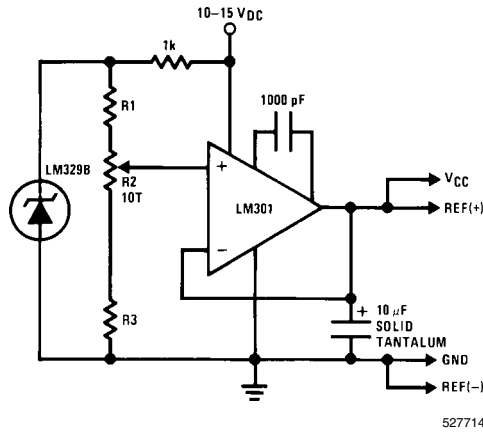
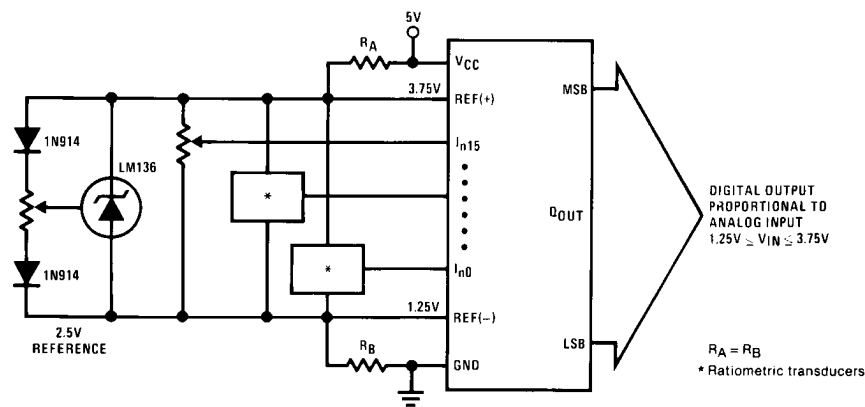

FIGURE 12. Typical Reference and Supply Circuit



527715

FIGURE 13. Symmetrically Centered Reference

3.0 Converter Equations

The transition between adjacent codes N and $N + 1$ is given by:

$$V_{IN} = \left\{ (V_{REF(+)} - V_{REF(-)}) \left[\frac{N}{256} + \frac{1}{512} \right] \pm V_{TUE} \right\} + V_{REF(-)}$$

(2)

The center of an output code N is given by:

$$V_{IN} = \left\{ (V_{REF(+)} - V_{REF(-)}) \left[\frac{N}{256} \right] \pm V_{TUE} \right\} + V_{REF(-)}$$

(3)

The output code N for an arbitrary input are the integers within the range:

$$N = \frac{V_{IN} - V_{REF(-)}}{V_{REF(+)} - V_{REF(-)}} \times 256 \pm \text{Absolute Accuracy}$$

(4)

where: V_{IN} = Voltage at comparator input

V_{REF} = Voltage at Ref(+)

V_{REF} = Voltage at Ref(-)

V_{TUE} = Total unadjusted error voltage (typically $V_{REF(+)} \div 512$)

4.0 Analog Comparator Inputs

The dynamic comparator input current is caused by the periodic switching of on-chip stray capacitances. These are connected alternately to the output of the resistor ladder/switch tree network and to the comparator input as part of the operation of the chopper stabilized comparator.

The average value of the comparator input current varies directly with clock frequency and with V_{IN} as shown in Figure 6.

If no filter capacitors are used at the analog or comparator inputs and the signal source impedances are low, the comparator input current should not introduce converter errors, as the transient created by the capacitance discharge will die out before the comparator output is strobed.

If input filter capacitors are desired for noise reduction and signal conditioning they will tend to average out the dynamic comparator input current. It will then take on the characteristics of a DC bias current whose effect can be predicted conventionally. See AN-258 for further discussion.

Typical Application

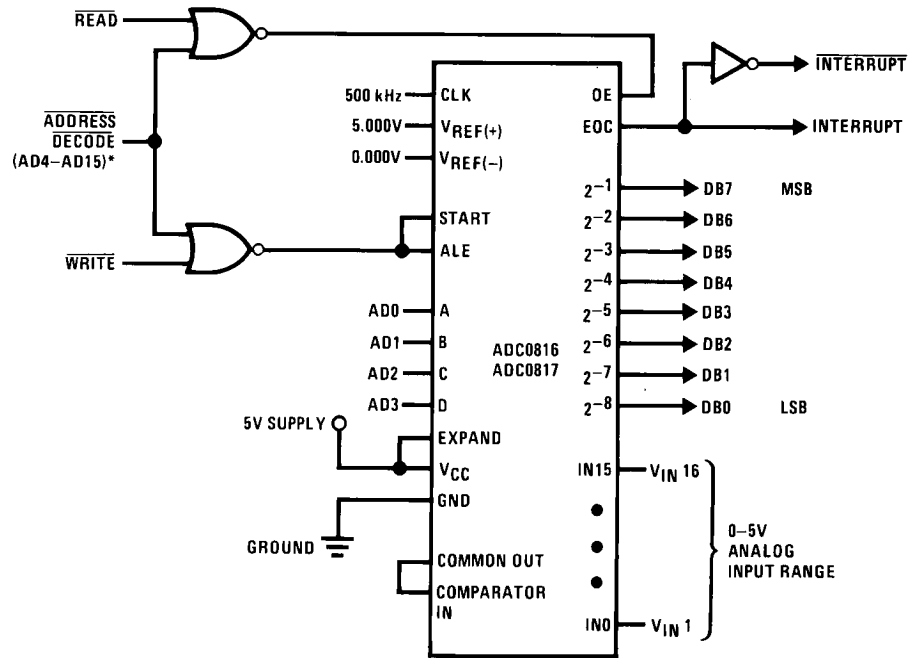

527716

*Address latches needed for 8085 and SC/MP interfacing the ADC0816, 17 to a microprocessor

Microprocessor Interface Table

PROCESSOR	READ	WRITE	INTERRUPT (COMMENT)
8080	MEMR	MEMW	INTR (Thru RST Circuit)
8085	\overline{RD}	\overline{WR}	INTR (Thru RST Circuit)
Z-80	\overline{RD}	\overline{WR}	\overline{INT} (Thru RST Circuit, Mode 0)
SC/MP	NRDS	NWDS	SA (Thru Sense A)
6800	$VMA \cdot \phi$ 2•R/W	$VMA \cdot Q_2 \cdot \overline{R/W}$	\overline{IRQA} or \overline{IRQB} (Thru PIA)

Physical Dimensions inches (millimeters) unless otherwise noted

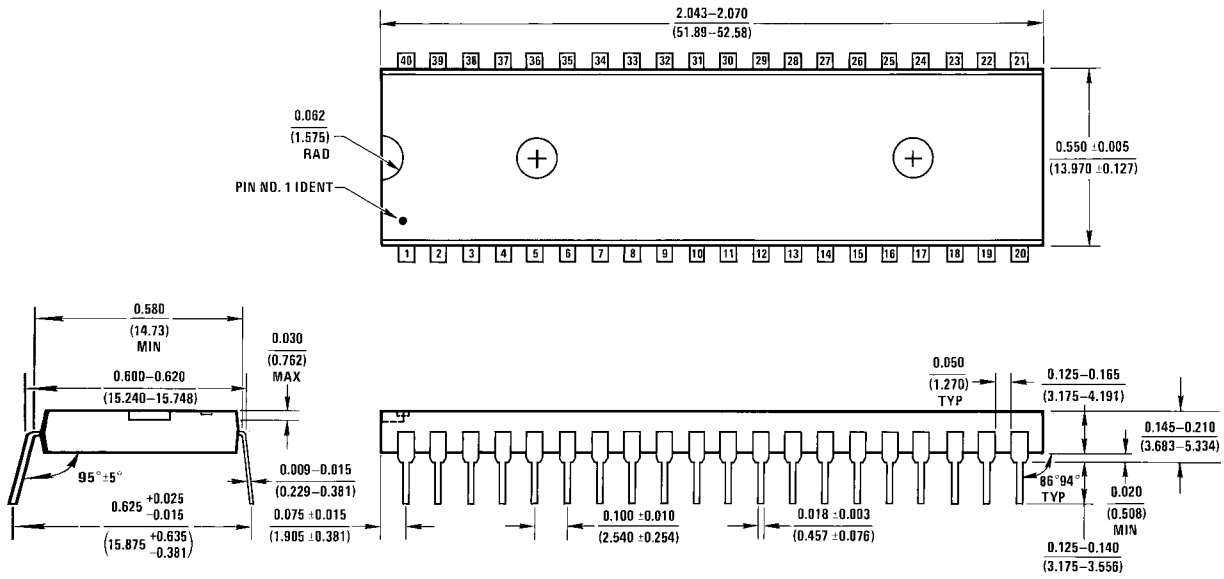

Molded Dual-In-Line Package (N)
NS Package Number N40A

N40A (REV E)

Notes

THE CONTENTS OF THIS DOCUMENT ARE PROVIDED IN CONNECTION WITH NATIONAL SEMICONDUCTOR CORPORATION ("NATIONAL") PRODUCTS. NATIONAL MAKES NO REPRESENTATIONS OR WARRANTIES WITH RESPECT TO THE ACCURACY OR COMPLETENESS OF THE CONTENTS OF THIS PUBLICATION AND RESERVES THE RIGHT TO MAKE CHANGES TO SPECIFICATIONS AND PRODUCT DESCRIPTIONS AT ANY TIME WITHOUT NOTICE. NO LICENSE, WHETHER EXPRESS, IMPLIED, ARISING BY ESTOPPEL OR OTHERWISE, TO ANY INTELLECTUAL PROPERTY RIGHTS IS GRANTED BY THIS DOCUMENT.

TESTING AND OTHER QUALITY CONTROLS ARE USED TO THE EXTENT NATIONAL DEEMS NECESSARY TO SUPPORT NATIONAL'S PRODUCT WARRANTY. EXCEPT WHERE MANDATED BY GOVERNMENT REQUIREMENTS, TESTING OF ALL PARAMETERS OF EACH PRODUCT IS NOT NECESSARILY PERFORMED. NATIONAL ASSUMES NO LIABILITY FOR APPLICATIONS ASSISTANCE OR BUYER PRODUCT DESIGN. BUYERS ARE RESPONSIBLE FOR THEIR PRODUCTS AND APPLICATIONS USING NATIONAL COMPONENTS. PRIOR TO USING OR DISTRIBUTING ANY PRODUCTS THAT INCLUDE NATIONAL COMPONENTS, BUYERS SHOULD PROVIDE ADEQUATE DESIGN, TESTING AND OPERATING SAFEGUARDS.

EXCEPT AS PROVIDED IN NATIONAL'S TERMS AND CONDITIONS OF SALE FOR SUCH PRODUCTS, NATIONAL ASSUMES NO LIABILITY WHATSOEVER, AND NATIONAL DISCLAIMS ANY EXPRESS OR IMPLIED WARRANTY RELATING TO THE SALE AND/OR USE OF NATIONAL PRODUCTS INCLUDING LIABILITY OR WARRANTIES RELATING TO FITNESS FOR A PARTICULAR PURPOSE, MERCHANTABILITY, OR INFRINGEMENT OF ANY PATENT, COPYRIGHT OR OTHER INTELLECTUAL PROPERTY RIGHT.

LIFE SUPPORT POLICY

NATIONAL'S PRODUCTS ARE NOT AUTHORIZED FOR USE AS CRITICAL COMPONENTS IN LIFE SUPPORT DEVICES OR SYSTEMS WITHOUT THE EXPRESS PRIOR WRITTEN APPROVAL OF THE CHIEF EXECUTIVE OFFICER AND GENERAL COUNSEL OF NATIONAL SEMICONDUCTOR CORPORATION. As used herein:

Life support devices or systems are devices which (a) are intended for surgical implant into the body, or (b) support or sustain life and whose failure to perform when properly used in accordance with instructions for use provided in the labeling can be reasonably expected to result in a significant injury to the user. A critical component is any component in a life support device or system whose failure to perform can be reasonably expected to cause the failure of the life support device or system or to affect its safety or effectiveness.

National Semiconductor and the National Semiconductor logo are registered trademarks of National Semiconductor Corporation. All other brand or product names may be trademarks or registered trademarks of their respective holders.

Copyright© 2007 National Semiconductor Corporation

For the most current product information visit us at www.national.com



**National Semiconductor
Americas Customer
Support Center**
Email:
new.feedback@nsc.com
Tel: 1-800-272-9959

**National Semiconductor Europe
Customer Support Center**
Fax: +49 (0) 180-530-85-86
Email: europe.support@nsc.com
Deutsch Tel: +49 (0) 69 9508 6208
English Tel: +49 (0) 870 24 0 2171
Français Tel: +33 (0) 1 41 91 8790

**National Semiconductor Asia
Pacific Customer Support Center**
Email: ap.support@nsc.com

**National Semiconductor Japan
Customer Support Center**
Fax: 81-3-5639-7507
Email: jpn.feedback@nsc.com
Tel: 81-3-5639-7560