



High-Speed, Closed-Loop Buffer

FEATURES

- **Wide Bandwidth: 1000MHz**
- **High Slew Rate: 8000V/μs**
- **Flexible Supply Range:**
 ±1.4V to ±6.3V Dual Supplies
 +2.8V to +12.6V Single Supply
- **Output Current: 60mA (continuous)**
- **Peak Output Current: 350mA**
- **Low Quiescent Current: 5.8mA**
- **Standard Buffer Pinout**
- **Optional Mid-Supply Reference Buffer**

APPLICATIONS

- **Low Impedance Reference Buffers**
- **Clock Distribution Circuits**
- **Video/Broadcast Equipment**
- **Communications Equipment**
- **High-Speed Data Acquisition**
- **Test Equipment and Instrumentation**

DESCRIPTION

The BUF602 is a closed-loop buffer recommended for a wide range of applications. Its wide bandwidth (1000MHz) and high slew rate (8000V/μs) make it ideal for buffering very high-frequency signals. For AC-coupled applications, an optional mid-point reference (V_{REF}) is provided, reducing the number of external components required and the necessary supply current to provide that reference.

The BUF602 is available in a standard SO-8 surface-mount package and in an SOT23-5 where a smaller footprint is needed.

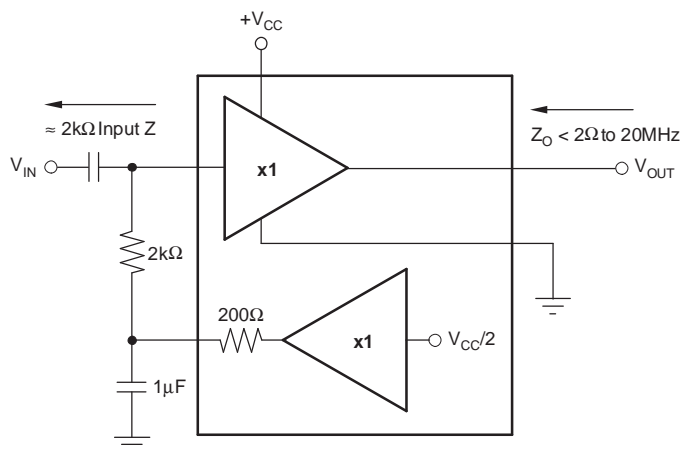

Self-Referenced, AC-Coupled, Single-Supply Buffer



Please be aware that an important notice concerning availability, standard warranty, and use in critical applications of Texas Instruments semiconductor products and disclaimers thereto appears at the end of this data sheet.

All trademarks are the property of their respective owners.



This integrated circuit can be damaged by ESD. Texas Instruments recommends that all integrated circuits be handled with appropriate precautions. Failure to observe proper handling and installation procedures can cause damage.

ESD damage can range from subtle performance degradation to complete device failure. Precision integrated circuits may be more susceptible to damage because very small parametric changes could cause the device not to meet its published specifications.

ORDERING INFORMATION⁽¹⁾

| PRODUCT | PACKAGE | PACKAGE DESIGNATOR | SPECIFIED TEMPERATURE RANGE | PACKAGE MARKING | ORDERING NUMBER | TRANSPORT MEDIA, QUANTITY |
|---------|---------|--------------------|-----------------------------|-----------------|-----------------|---------------------------|
| BUF602 | SO-8 | D | -45°C to +85°C | BUF602 | BUF602ID | Rails, 75 |
| | | | | | BUF602IDR | Tape and Reel, 2500 |
| BUF602 | SOT23-5 | DBV | -45°C to +85°C | AWO | BUF602IDBVT | Tape and Reel, 250 |
| | | | | | BUF602IDBVR | Tape and Reel, 3000 |

(1) For the most current package and ordering information, see the Package Option Addendum at the end of this document or see the TI web site at www.ti.com.

ABSOLUTE MAXIMUM RATINGS⁽¹⁾

| | |
|----------------------------------------|-------------------------|
| Power Supply | ±6.5V _{DC} |
| Internal Power Dissipation | See Thermal Information |
| Input Common-Mode Voltage Range | ±V _S |
| Storage Temperature Range: D, DBV | -65°C to +125°C |
| Lead Temperature (soldering, 10s) | +300°C |
| Junction Temperature (T _J) | +150°C |
| ESD Rating: | |
| Human Body Model (HBM) | 2000V |
| Charge Device Model (CDM) | 1000V |
| Machine Model (MM) | 200V |

(1) Stresses above these ratings may cause permanent damage. Exposure to absolute maximum conditions for extended periods may degrade device reliability. These are stress ratings only, and functional operation of the device at these or any other conditions beyond those specified is not supported.

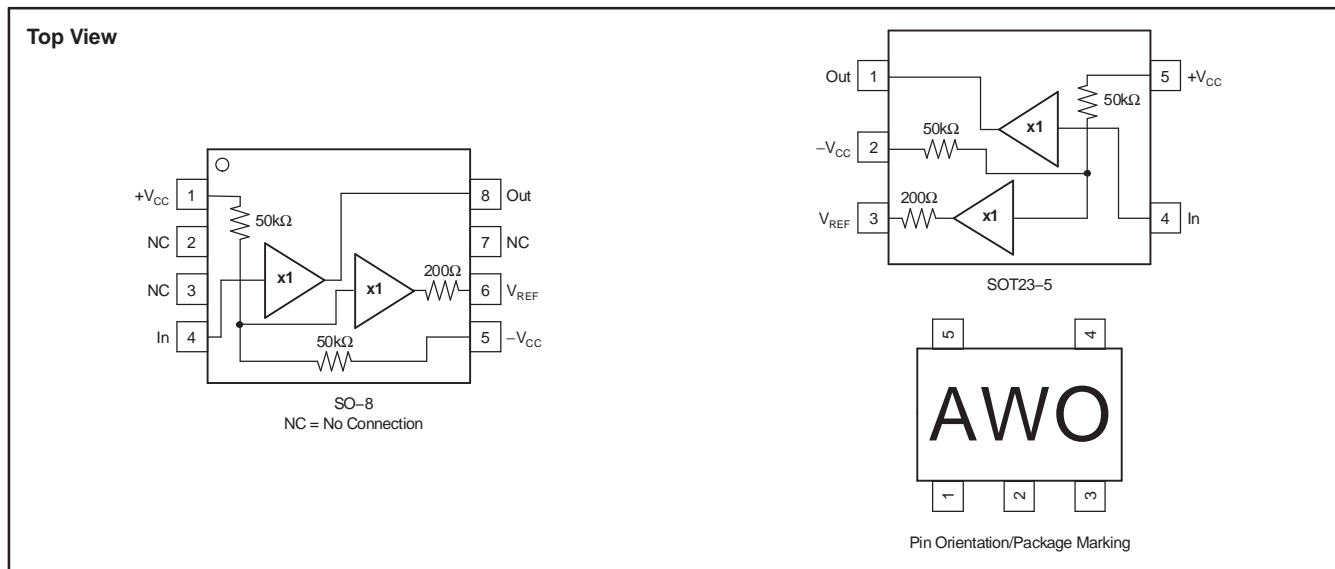

ELECTRICAL CHARACTERISTICS: $V_S = \pm 5V$
Boldface limits are tested at **+25°C**.

 At $R_L = 100\Omega$, unless otherwise noted.

| PARAMETER | CONDITIONS | BUF602ID, IDBV | | | | UNITS | MIN/ MAX | TEST LEVEL ⁽¹⁾ |
|--------------------------------------------|-------------------------------|----------------|-----------------------------|-------------------------------|----------------------------------|------------------|-------------|---------------------------|
| | | TYP | MIN/MAX OVER TEMPERATURE | | | | | |
| | | +25°C | +25°C ⁽²⁾ | 0°C to 70°C ⁽³⁾ | –40°C to +85°C ⁽³⁾ | | | |
| AC PERFORMANCE | | | | | | | | |
| Bandwidth | (See figure 30) | | | | | | | |
| | $V_O = 500mV_{PP}$ | 1000 | 560 | 550 | 540 | MHz | min | B |
| | $V_O = 1V_{PP}$ | 920 | | | | MHz | typ | C |
| Full Power Bandwidth | $V_O = 5V_{PP}$ | 880 | | | | MHz | typ | C |
| Bandwidth for 0.1dB Flatness | $V_O = 500mV_{PP}$ | 240 | | | | MHz | typ | C |
| Slew Rate | $V_O = 5V$ Step | 8000 | 7000 | 6000 | 5000 | V/ μ s | min | B |
| Rise Time and Fall Time | $V_O = 0.2V$ Step | 350 | 625 | 640 | 650 | ps | max | B |
| Settling Time to 0.05% | $V_O = 1V$ Step | 6 | | | | ns | typ | C |
| Harmonic Distortion | $V_O = 2V_{PP}$, 5MHz | | | | | | | |
| 2nd-Harmonic | $R_L = 100\Omega$ | –57 | –44 | –44 | –42 | dBc | max | B |
| | $R_L = 500\Omega$ | –76 | –63 | –62 | –60 | dBc | max | B |
| 3rd-Harmonic | $R_L = 100\Omega$ | –68 | –63 | –63 | –63 | dBc | max | B |
| | $R_L = 500\Omega$ | –98 | –85 | –84 | –82 | dBc | max | B |
| Input Voltage Noise | $f > 100kHz$ | 4.8 | 5.1 | 5.6 | 6.0 | nV/ \sqrt{Hz} | max | B |
| Input Current Noise | $f > 100kHz$ | 2.1 | 2.6 | 2.7 | 2.8 | pA/ \sqrt{Hz} | max | B |
| Differential Gain | NTSC, $R_L = 150\Omega$ to 0V | 0.15 | | | | % | typ | C |
| Differential Phase | NTSC, $R_L = 150\Omega$ to 0V | 0.04 | | | | ° | typ | C |
| BUFFER DC PERFORMANCE⁽⁴⁾ | | | | | | | | |
| Maximum Gain | $R_L = 500\Omega$ | 0.99 | 1 | 1 | 1 | V/V | max | A |
| Minimum Gain | $R_L = 500\Omega$ | 0.99 | 0.98 | 0.98 | 0.98 | V/V | min | A |
| Input Offset Voltage | | ± 16 | ± 30 | ± 36 | ± 38 | mV | max | A |
| Average Input Offset Voltage Drift | | | | ± 125 | ± 125 | μ V/°C | max | B |
| Input Bias Current | | ± 3 | ± 7 | ± 8 | ± 8.5 | μ A | max | A |
| Average Input Bias Current Drift | | | | ± 20 | ± 20 | nA/°C | max | B |
| BUFFER INPUT | | | | | | | | |
| Input Impedance | | 1.0 2.1 | | | | M Ω pF | typ | C |
| BUFFER OUTPUT | | | | | | | | |
| Output Voltage Swing | $R_L = 100\Omega$ | ± 3.8 | ± 3.7 | ± 3.7 | ± 3.7 | V | min | B |
| | $R_L = 500\Omega$ | ± 4.0 | ± 3.8 | ± 3.8 | ± 3.8 | V | min | A |
| Output Current (Continuous) | $V_O = 0V$ | ± 60 | ± 50 | ± 49 | ± 48 | mA | min | A |
| Peak Output Current | $V_O = 0V$ | ± 350 | | | | mA | typ | C |
| Closed-Loop Output Impedance | $f \leq 10MHz$ | 1.4 | | | | Ω | typ | C |
| POWER SUPPLY | | | | | | | | |
| Specified Operating Voltage | | ± 5 | | | | V | typ | C |
| Maximum Operating Voltage | | | ± 6.3 | ± 6.3 | ± 6.3 | V | max | A |
| Minimum Operating Voltage | | | ± 1.4 | ± 1.4 | ± 1.4 | V | min | B |
| Maximum Quiescent Current | $V_S = \pm 5V$ | 5.8 | 6.3 | 6.9 | 7.2 | mA | max | A |
| Minimum Quiescent Current | $V_S = \pm 5V$ | 5.8 | 5.3 | 4.9 | 4.3 | mA | min | A |
| Power-Supply Rejection Ratio (+PSRR) | | 54 | 48 | 46 | 45 | dB | min | A |
| THERMAL CHARACTERISTICS | | | | | | | | |
| Specification: ID | | –40 to +85 | | | | °C | typ | C |
| Thermal Resistance θ_{JA} | | | | | | | | |
| D SO-8 | Junction-to-Ambient | 125 | | | | °C/W | typ | C |
| DBV SOT23-5 | Junction-to-Ambient | 150 | | | | °C/W | typ | C |

- (1) Test levels: (A) 100% tested at +25°C. Over temperature limits set by characterization and simulation. (B) Limits set by characterization and simulation. (C) Typical value only for information.
- (2) Junction temperature = ambient for +25°C specifications.
- (3) Junction temperature = ambient at low temperature limit; junction temperature = ambient +8°C at high temperature limit for over temperature specifications.
- (4) Current is considered positive out of node.

ELECTRICAL CHARACTERISTICS: $V_S = +5V$

Boldface limits are tested at **+25°C**.

At $R_L = 100\Omega$ to $V_S/2$, unless otherwise noted.

| PARAMETER | CONDITIONS | BUF602ID, IDBV | | | | UNITS | MIN/MAX | TEST LEVEL ⁽¹⁾ |
|--------------------------------------------|---------------------------------------|----------------|----------------------------|----------------------------|-------------------------------|------------------|---------|---------------------------|
| | | TYP | MIN/MAX OVER TEMPERATURE | | | | | |
| | | +25°C | +25°C ⁽²⁾ | 0°C to 70°C ⁽³⁾ | -40°C to +85°C ⁽³⁾ | | | |
| AC PERFORMANCE | | | | | | | | |
| Bandwidth | (See figure 31) $V_O = 500mV_{PP}$ | 780 | 400 | 400 | 390 | MHz | min | B |
| | $V_O = 1V_{PP}$ | 700 | | | | MHz | typ | C |
| Full-Power Bandwidth | $V_O = 3V_{PP}$ | 420 | | | | MHz | typ | C |
| Bandwidth for 0.1dB Flatness | $V_O = 500mV_{PP}$ | 130 | | | | MHz | typ | C |
| Slew Rate | $V_O = 3V$ Step | 2500 | 1800 | 1600 | 1400 | V/ μ s | min | B |
| Rise Time and Fall Time | $V_O = 0.2V$ Step | 450 | 875 | 875 | 900 | ps | max | B |
| Settling Time to 0.05% | $V_O = 1V$ Step | 6 | | | | ns | typ | C |
| Harmonic Distortion | $V_O = 2V_{PP}$, 5MHz | | | | | | | |
| 2nd-Harmonic | $R_L = 100\Omega$ | -50 | -45 | -44 | -43 | dBc | max | B |
| | $R_L = 500\Omega$ | -73 | -62 | -61 | -60 | dBc | max | B |
| 3rd-Harmonic | $R_L = 100\Omega$ | -70 | -64 | -64 | -63 | dBc | max | B |
| | $R_L = 500\Omega$ | -73 | -72 | -72 | -71 | dBc | max | B |
| Input Voltage Noise | $f > 100kHz$ | 4.9 | 5.2 | 5.7 | 6.1 | nV/ \sqrt{Hz} | max | B |
| Input Current Noise | $f > 100kHz$ | 2.2 | 2.7 | 2.8 | 2.9 | pA/ \sqrt{Hz} | max | B |
| Differential Gain | NTSC, $R_L = 100\Omega$ to $V_S/2$ | 0.16 | | | | % | typ | C |
| Differential Phase | NTSC, $R_L = 100\Omega$ to $V_S/2$ | 0.05 | | | | ° | typ | C |
| BUFFER DC PERFORMANCE⁽⁴⁾ | | | | | | | | |
| Maximum Gain | $R_L = 500\Omega$ | 0.99 | 1 | 1 | 1 | V/V | max | A |
| Minimum Gain | $R_L = 500\Omega$ | 0.99 | 0.98 | 0.98 | 0.98 | V/V | min | A |
| Input Offset Voltage | | ± 16 | ± 30 | ± 36 | ± 38 | mV | max | A |
| Average Input Offset Voltage Drift | | | | ± 125 | ± 125 | $\mu V/^\circ C$ | max | B |
| Input Bias Current | | ± 3 | ± 7 | ± 8 | ± 8.5 | μA | max | A |
| Average Input Bias Current Drift | | | | ± 20 | ± 20 | nA/ $^\circ C$ | max | B |
| BUFFER INPUT | | | | | | | | |
| Input Impedance | | 1.0 2.1 | | | | M Ω pF | typ | C |
| BUFFER OUTPUT | | | | | | | | |
| Most Positive Output Voltage | $R_L = 100\Omega$ | +3.9 | +3.7 | +3.7 | +3.7 | V | min | B |
| | $R_L = 500\Omega$ | +4.1 | +3.8 | +3.8 | +3.8 | V | min | A |
| Least Positive Output Voltage | $R_L = 100\Omega$ | +1.1 | +1.3 | +1.3 | +1.3 | V | max | B |
| | $R_L = 500\Omega$ | +0.9 | +1.2 | +1.2 | +1.2 | V | max | A |
| Output Current (Continuous) | $V_O = 0V$ | ± 60 | ± 50 | ± 49 | ± 48 | mA | min | A |
| Peak Output Current | $V_O = 0V$ | ± 160 | | | | mA | typ | C |
| Closed-Loop Output Impedance | $f \leq 10MHz$ | 1.4 | | | | Ω | typ | C |
| MID-POINT REFERENCE OUTPUT | | | | | | | | |
| Maximum Mid-Supply Reference Voltage | | 2.5 | 2.6 | 2.6 | 2.6 | V | max | A |
| Minimum Mid-Supply Reference Voltage | | 2.5 | 2.4 | 2.4 | 2.4 | V | min | A |
| Mid-Supply Output Current, Sourcing | | 800 | | | | μA | typ | C |
| Mid-Supply Output Current, Sinking | | 70 | | | | μA | typ | C |
| Mid-Supply Output Impedance | | 200 | | | | Ω | typ | C |

- (1) Test levels: (A) 100% tested at +25°C. Over temperature limits set by characterization and simulation. (B) Limits set by characterization and simulation. (C) Typical value only for information.
- (2) Junction temperature = ambient for +25°C specifications.
- (3) Junction temperature = ambient at low temperature limit; junction temperature = ambient +4°C at high temperature limit for over temperature specifications.
- (4) Current is considered positive out of node.

ELECTRICAL CHARACTERISTICS: $V_S = +5V$ (continued)
Boldface limits are tested at **+25°C**.

 At $R_L = 100\Omega$ to $V_S/2$, unless otherwise noted.

| PARAMETER | CONDITIONS | BUF602ID, IDBV | | | | UNITS | MIN/ MAX | TEST LEVEL ⁽¹⁾ |
|--------------------------------------|---------------------|----------------|--------------------------|-------------------------------|----------------------------------|-------|-------------|---------------------------|
| | | TYP | MIN/MAX OVER TEMPERATURE | | | | | |
| | | +25°C | +25°C ⁽²⁾ | 0°C to 70°C ⁽³⁾ | –40°C to +85°C ⁽³⁾ | | | |
| POWER SUPPLY | | | | | | | | |
| Specified Operating Voltage | | +5 | | | | V | typ | C |
| Maximum Operating Voltage | | | +12.6 | +12.6 | +12.6 | V | max | A |
| Minimum Operating Voltage | | | +2.8 | +2.8 | +2.8 | V | min | B |
| Maximum Quiescent Current | $V_S = +5V$ | 5.3 | 5.8 | 6.3 | 6.5 | mA | max | A |
| Minimum Quiescent Current | $V_S = +5V$ | 5.3 | 4.8 | 4.5 | 3.9 | mA | min | A |
| Power-Supply Rejection Ratio (+PSRR) | | 52 | 46 | 44 | 43 | dB | min | A |
| THERMAL CHARACTERISTICS | | | | | | | | |
| Specification: ID | | –40 to +85 | | | | °C | typ | C |
| Thermal Resistance θ_{JA} | | | | | | | | |
| D SO-8 | Junction-to-Ambient | 125 | | | | °C/W | typ | C |
| DBV SOT23-5 | Junction-to-Ambient | 150 | | | | °C/W | typ | C |

ELECTRICAL CHARACTERISTICS: $V_S = +3.3V$

Boldface limits are tested at **+25°C**.

At $R_L = 100\Omega$, unless otherwise noted.

| PARAMETER | CONDITIONS | BUF602ID, IDBV | | | | UNITS | MIN/ MAX | TEST LEVEL ⁽¹⁾ |
|--------------------------------------------|------------------------|----------------|----------------------------|-------------------------------|----------------------------------|------------------|-------------|---------------------------|
| | | TYP | MIN/MAX OVER TEMPERATURE | | | | | |
| | | +25°C | +25°C ⁽²⁾ | 0°C to 70°C ⁽³⁾ | -40°C to +85°C ⁽³⁾ | | | |
| AC PERFORMANCE | | | | | | | | |
| Bandwidth | $V_O = 500mV_{PP}$ | 600 | 320 | 320 | 310 | MHz | min | B |
| Full Power Bandwidth | $V_O = 1V_{PP}$ | 520 | | | | MHz | typ | C |
| Bandwidth for 0.1dB Flatness | $V_O = 500mV_{PP}$ | 110 | | | | MHz | typ | C |
| Slew Rate | $V_O = 1.4V$ Step | 800 | 650 | 600 | 600 | V/ μs | min | B |
| Rise Time and Fall Time | $V_O = 0.2V$ Step | 580 | 1100 | 1100 | 1150 | ps | max | B |
| Settling Time to 0.05% | $V_O = 1V$ Step | 6.5 | | | | ns | typ | C |
| Harmonic Distortion | $V_O = 1V_{PP}$, 5MHz | | | | | | | |
| 2nd-Harmonic | $R_L = 100\Omega$ | -59 | -49 | -49 | -48 | dBc | max | B |
| | $R_L = 500\Omega$ | -76 | -61 | -57 | -53 | dBc | max | B |
| 3rd-Harmonic | $R_L = 100\Omega$ | -70 | -51 | -48 | -44 | dBc | max | B |
| | $R_L = 500\Omega$ | -63 | -51 | -48 | -44 | dBc | max | B |
| Input Voltage Noise | $f > 100kHz$ | 4.9 | 5.2 | 5.7 | 6.1 | nV/ \sqrt{Hz} | max | B |
| Input Current Noise | $f > 100kHz$ | 2.2 | 2.7 | 2.8 | 2.9 | pA/ \sqrt{Hz} | max | B |
| BUFFER DC PERFORMANCE⁽⁴⁾ | | | | | | | | |
| Maximum Gain | $R_L = 500\Omega$ | 0.99 | 1 | 1 | 1 | V/V | max | A |
| Minimum Gain | $R_L = 500\Omega$ | 0.99 | 0.98 | 0.98 | 0.98 | V/V | min | A |
| Input Offset Voltage | | ± 16 | ± 30 | ± 36 | ± 38 | mV | max | A |
| Average Input Offset Voltage Drift | | | | ± 125 | ± 125 | $\mu V/^\circ C$ | max | B |
| Input Bias Current | | ± 3 | ± 7 | ± 8 | ± 8.5 | μA | max | A |
| Average Input Bias Current Drift | | | | ± 20 | ± 20 | nA/ $^\circ C$ | max | B |
| BUFFER INPUT | | | | | | | | |
| Input Impedance | | 1.0 2.1 | | | | M Ω pF | typ | C |
| BUFFER OUTPUT | | | | | | | | |
| Most Positive Output Voltage | $R_L = 100\Omega$ | +2.1 | +2.0 | +2.0 | +2.0 | V | min | B |
| | $R_L = 500\Omega$ | +2.3 | +2.2 | +2.2 | +2.2 | V | min | A |
| Least Positive Output Voltage | $R_L = 100\Omega$ | +1.2 | +1.3 | +1.3 | +1.3 | V | max | B |
| | $R_L = 500\Omega$ | +1.0 | +1.1 | +1.1 | +1.1 | V | max | A |
| Output Current (Continuous) | $V_O = 0$ | ± 60 | ± 50 | ± 49 | ± 48 | mA | min | A |
| Peak Output Current | | ± 100 | | | | mA | typ | C |
| Closed-Loop Output Impedance | $f \leq 10MHz$ | 1.4 | | | | Ω | typ | C |
| MID-POINT REFERENCE OUTPUT | | | | | | | | |
| Maximum Mid-Supply Reference Voltage | | 1.65 | 1.72 | 1.72 | 1.72 | V | max | A |
| Minimum Mid-Supply Reference Voltage | | 1.65 | 1.58 | 1.58 | 1.58 | V | min | A |
| Mid-Supply Output Current, Sourcing | | 500 | | | | μA | typ | C |
| Mid-Supply Output Current, Sinking | | 60 | | | | μA | typ | C |
| Mid-Supply Output Impedance | | 200 | | | | Ω | typ | C |
| POWER SUPPLY | | | | | | | | |
| Specified Operating Voltage | | +3.3 | | | | V | typ | C |
| Maximum Operating Voltage | | | +12.6 | +12.6 | +12.6 | V | max | A |
| Minimum Operating Voltage | | | +2.8 | +2.8 | +2.8 | V | min | B |
| Maximum Quiescent Current | $V_S = +3.3V$ | 5.0 | 5.5 | 6.0 | 6.3 | mA | max | A |
| Minimum Quiescent Current | $V_S = +3.3V$ | 5.0 | 4.5 | 4.2 | 3.8 | mA | min | A |
| Power-Supply Rejection Ratio (+PSRR) | | 50 | 44 | 42 | 41 | dB | min | A |

- (1) Test levels: (A) 100% tested at +25°C. Over temperature limits set by characterization and simulation. (B) Limits set by characterization and simulation. (C) Typical value only for information.
- (2) Junction temperature = ambient for +25°C specifications.
- (3) Junction temperature = ambient at low temperature limit; junction temperature = ambient +2°C at high temperature limit for over temperature specifications.
- (4) Current is considered positive out of node.

ELECTRICAL CHARACTERISTICS: $V_S = +3.3V$ (continued)
Boldface limits are tested at **+25°C**.

 At $R_L = 100\Omega$, unless otherwise noted.

| PARAMETER | CONDITIONS | BUF602ID, IDBV | | | | UNITS | MIN/ MAX | TEST LEVEL ⁽¹⁾ |
|----------------------------------|---------------------|----------------|--------------------------|-------------------------------|----------------------------------|-------|-------------|---------------------------|
| | | TYP | MIN/MAX OVER TEMPERATURE | | | | | |
| | | +25°C | +25°C ⁽²⁾ | 0°C to 70°C ⁽³⁾ | –40°C to +85°C ⁽³⁾ | | | |
| THERMAL CHARACTERISTICS | | | | | | | | |
| Specification: ID | | –40 to +85 | | | | °C | typ | C |
| Thermal Resistance θ_{JA} | | | | | | | | |
| D SO-8 | Junction-to-Ambient | 125 | | | | °C/W | typ | C |
| DBV SOT23-5 | Junction-to-Ambient | 150 | | | | °C/W | typ | C |

TYPICAL CHARACTERISTICS: $V_S = \pm 5V$
 At $T_A = +25^\circ C$ and $R_L = 100\Omega$, unless otherwise noted.

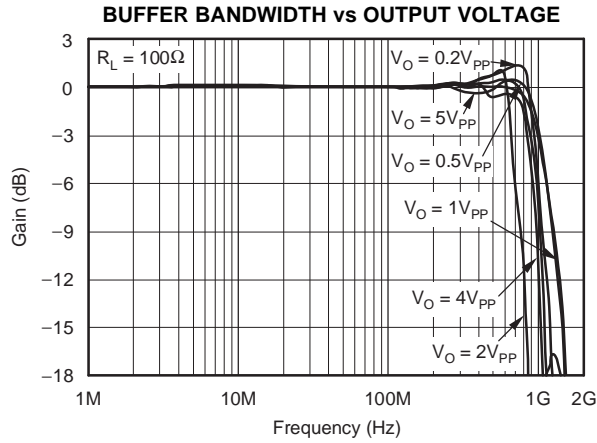

Figure 1.

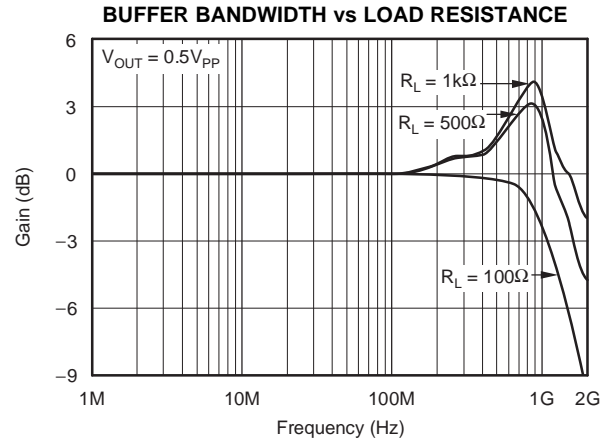

Figure 2.

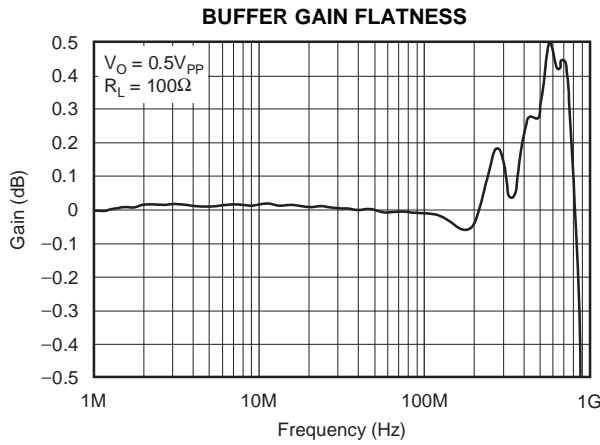

Figure 3.

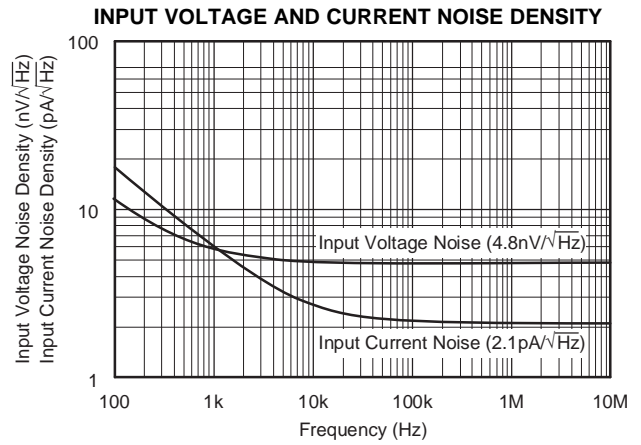

Figure 4.

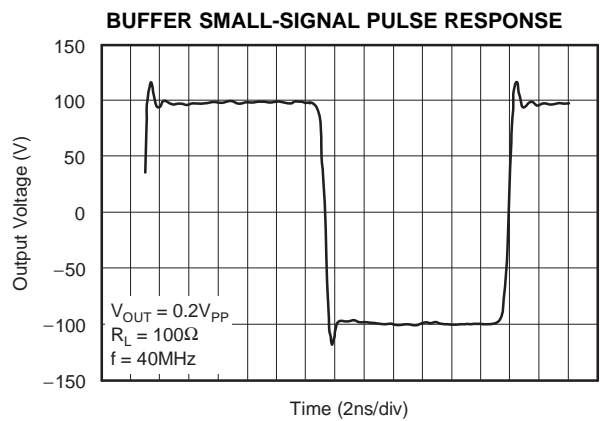

Figure 5.

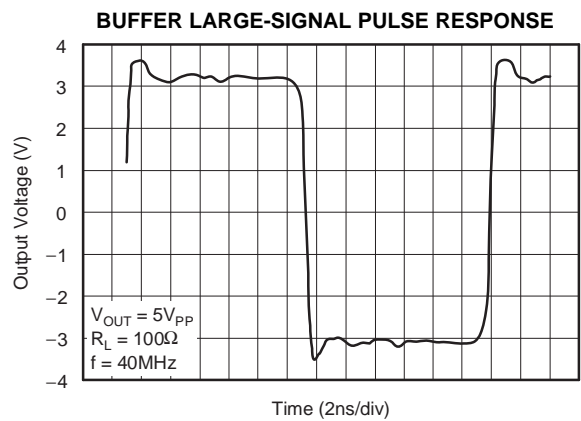

Figure 6.

TYPICAL CHARACTERISTICS: $V_S = \pm 5V$ (continued)

At $T_A = +25^\circ C$ and $R_L = 100\Omega$, unless otherwise noted.

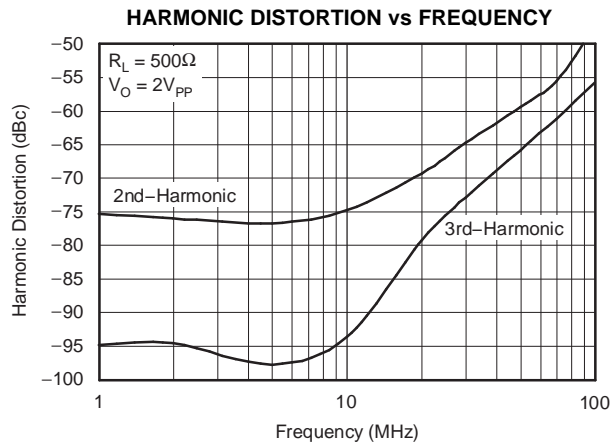

Figure 7.

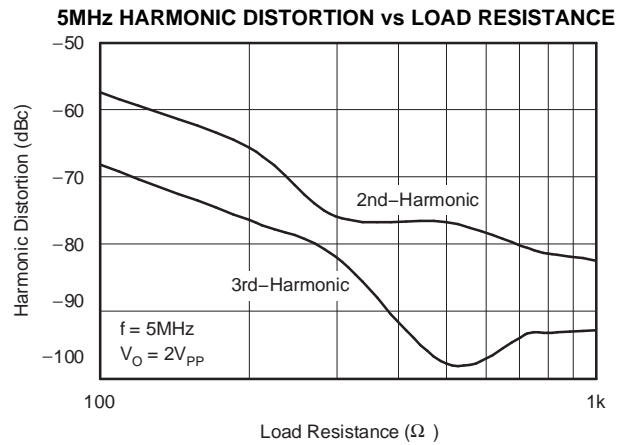

Figure 8.

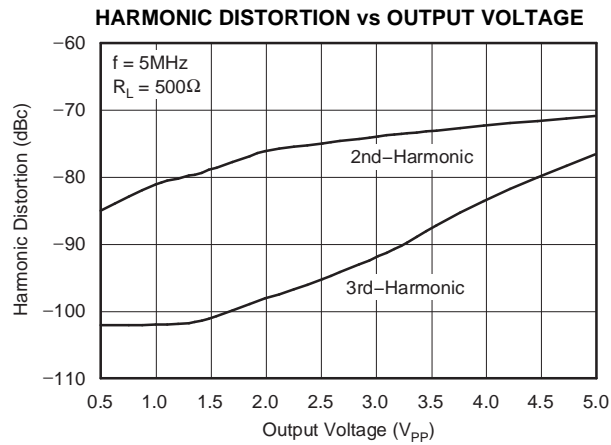

Figure 9.

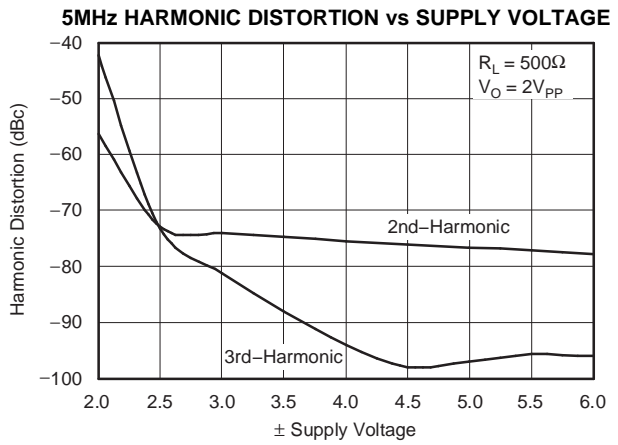

Figure 10.

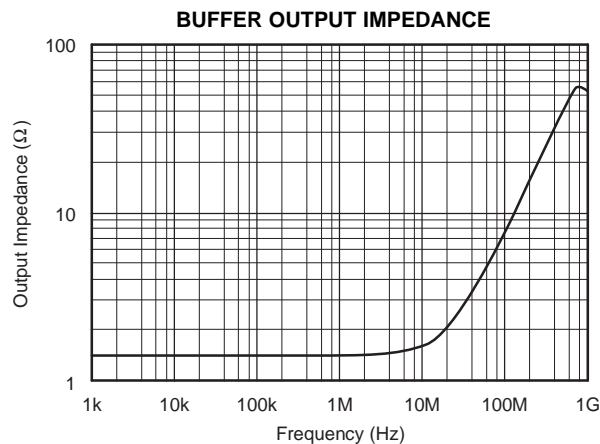

Figure 11.

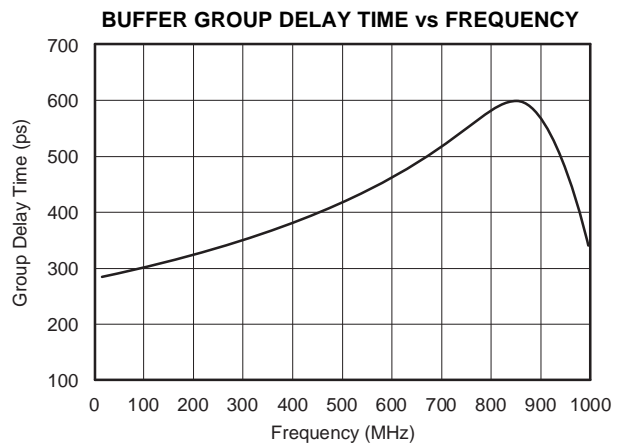

Figure 12.

TYPICAL CHARACTERISTICS: $V_S = \pm 5V$ (continued)

At $T_A = +25^\circ C$ and $R_L = 100\Omega$, unless otherwise noted.

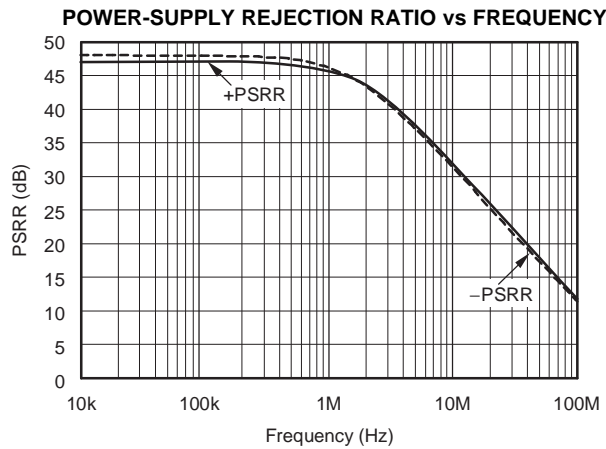

Figure 13.

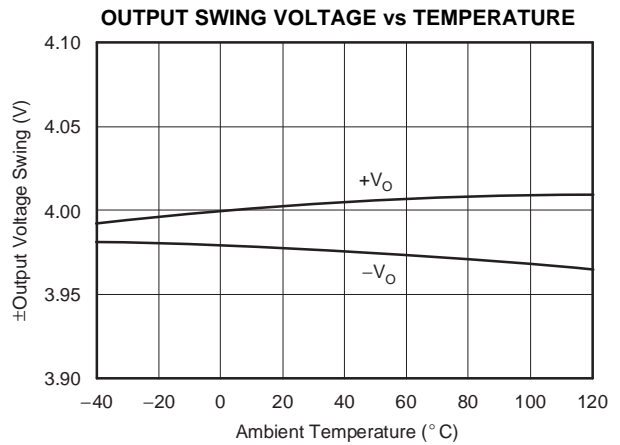

Figure 14.

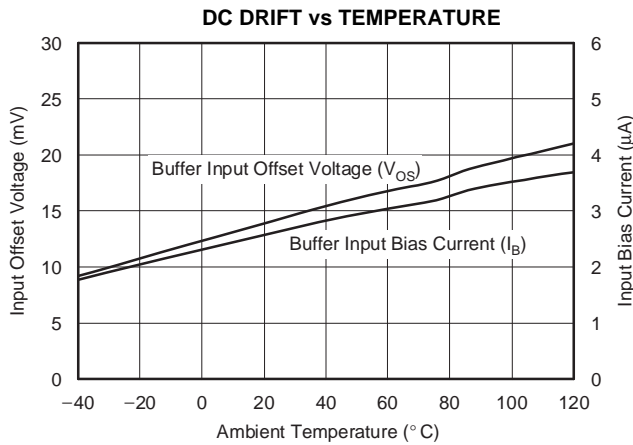

Figure 15.

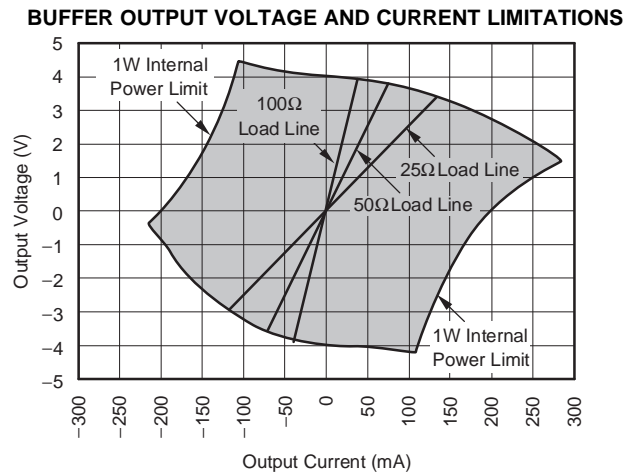

Figure 16.

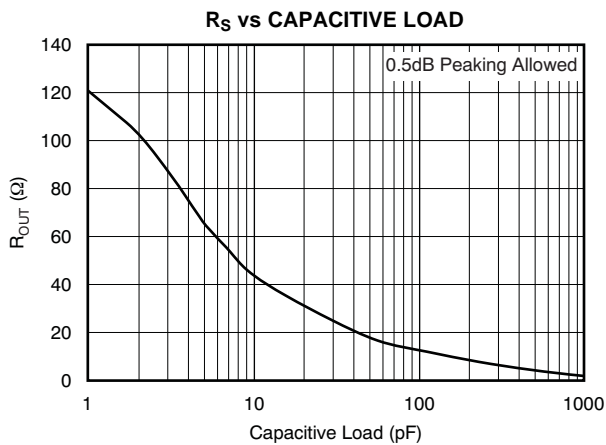

Figure 17.

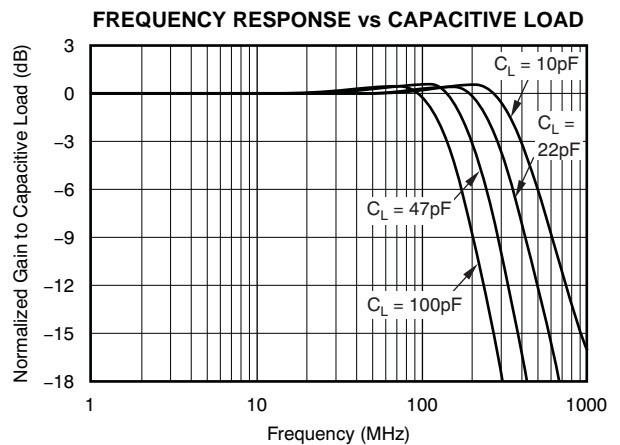

Figure 18.

TYPICAL CHARACTERISTICS: $V_S = +5V$

At $T_A = +25^\circ C$ and $R_L = 100\Omega$ to $V_S/2$, unless otherwise noted.

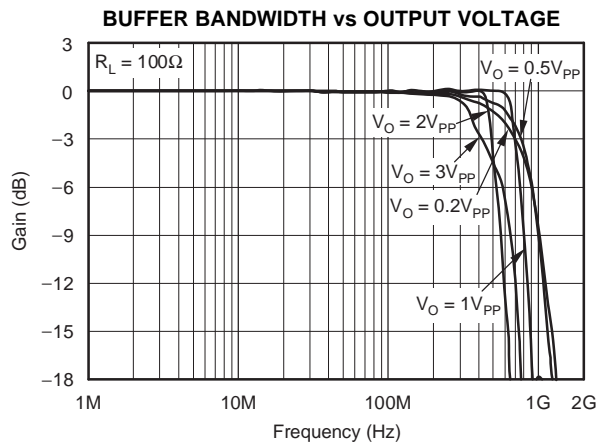

Figure 19.

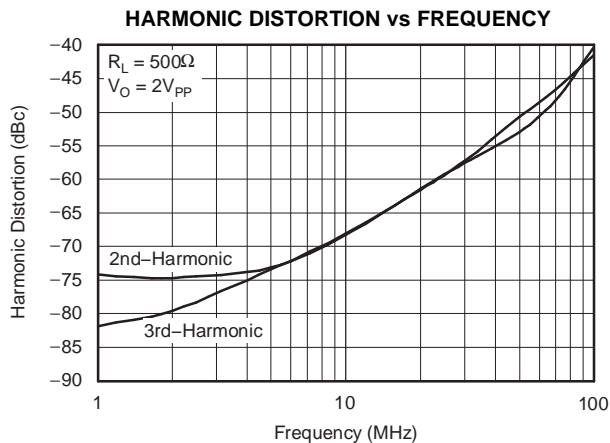

Figure 20.

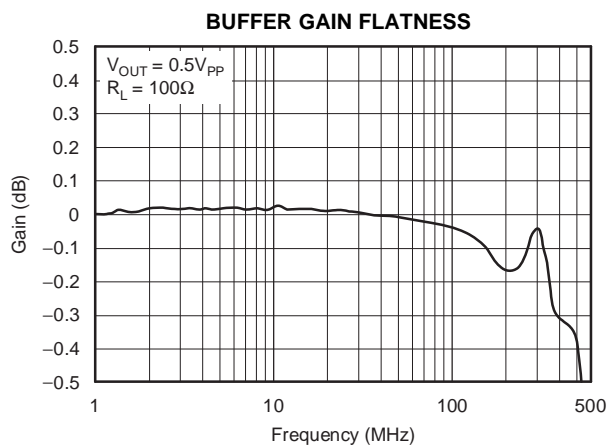

Figure 21.

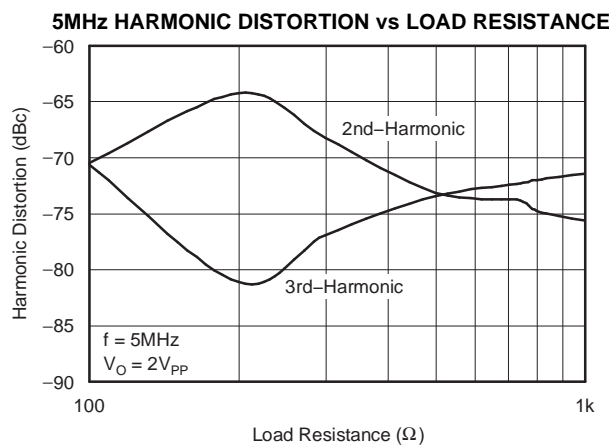

Figure 22.

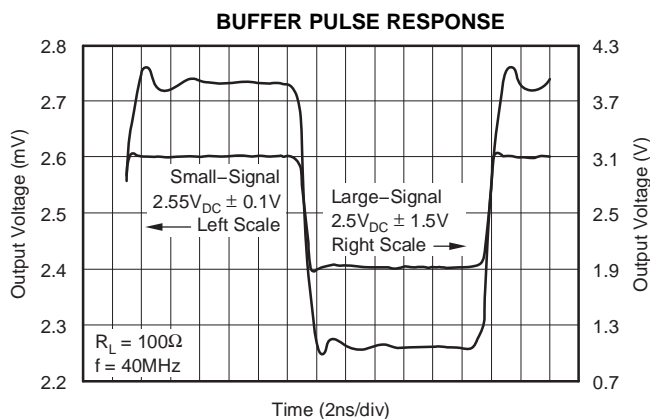

Figure 23.

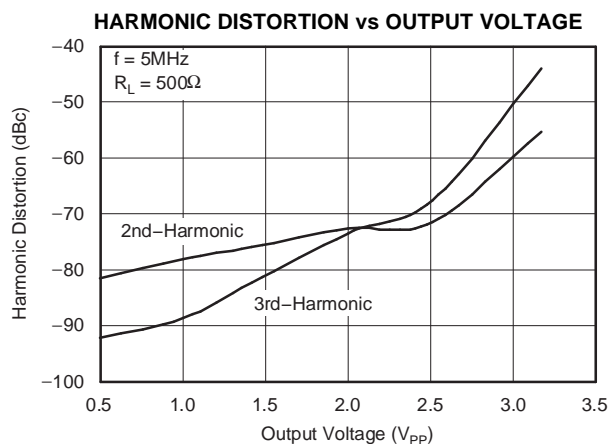

Figure 24.

TYPICAL CHARACTERISTICS: $V_S = +3.3V$

At $T_A = +25^\circ C$ and $R_L = 100\Omega$ to $V_S/2$, unless otherwise noted.

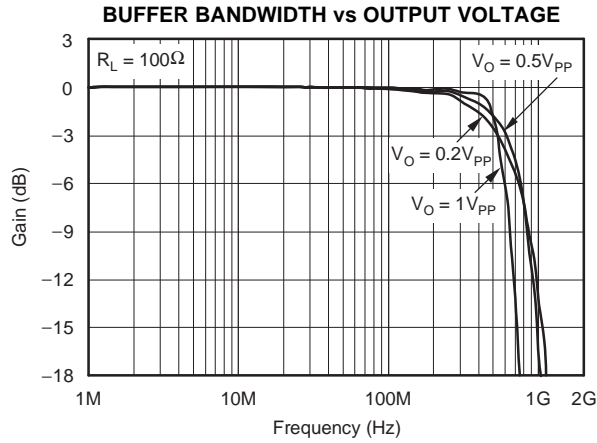

Figure 25.

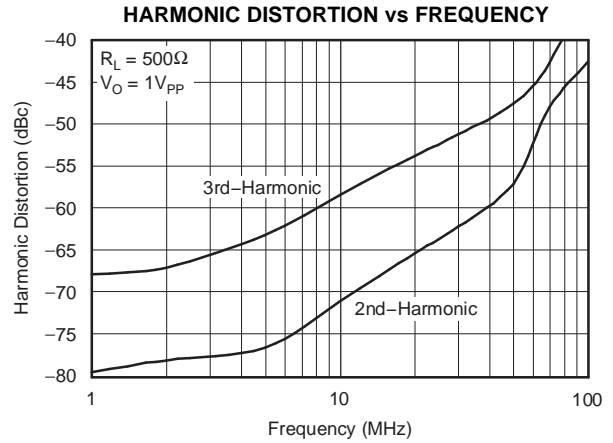

Figure 26.

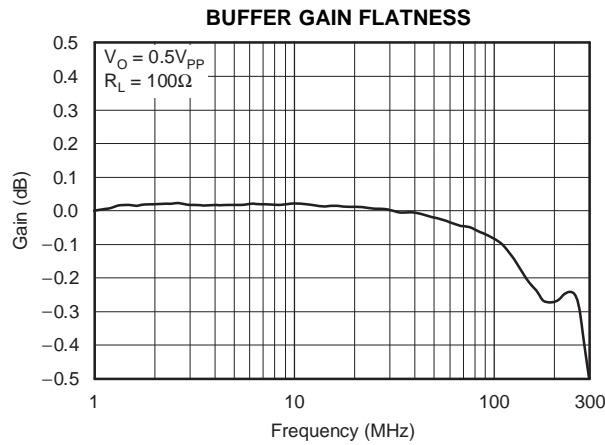

Figure 27.

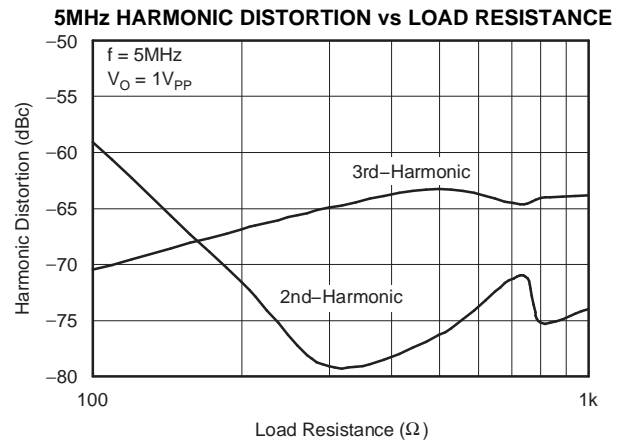

Figure 28.

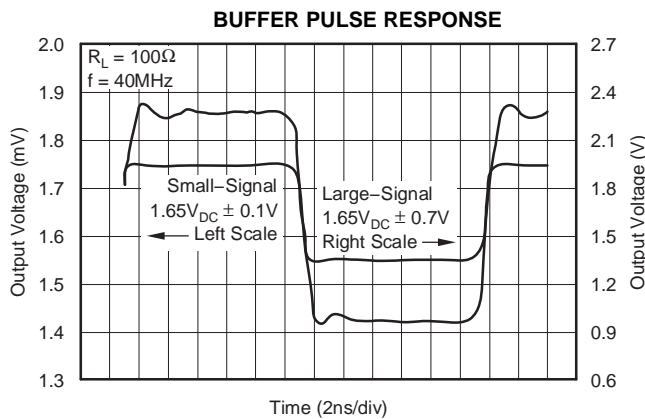

Figure 29.

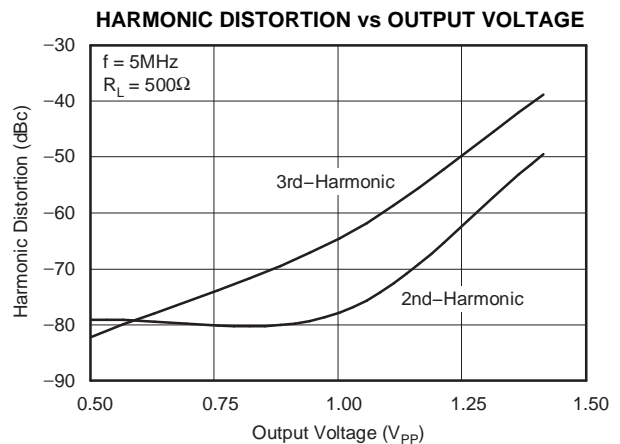

Figure 30.

APPLICATION INFORMATION

WIDEBAND BUFFER OPERATION

The BUF602 gives the exceptional AC performance of a wideband buffer. Requiring only 5.8mA quiescent current, the BUF602 will swing to within 1V of either supply rail and deliver in excess of 60mA at room temperature. This low output headroom requirement, along with supply voltage independent biasing, gives remarkable single (+5V) supply operation. The BUF602 will deliver greater than 500MHz bandwidth driving a 2V_{PP} output into 100Ω on a single +5V supply.

Figure 31 shows the DC-coupled, dual power-supply circuit configuration used as the basis of the ±5V Electrical and Typical Characteristics. For test purposes, the input impedance is set to 50Ω with a resistor to ground and the output impedance is set to 50Ω with a series output resistor. Voltage swings reported in the specifications are taken directly at the input and output pins while load powers (dBm) are defined at a matched 50Ω load. In addition to the usual power-supply decoupling capacitors to ground, a 0.01μF capacitor can be included between the two power-supply pins. This optional added capacitor will typically improve the 2nd-harmonic distortion performance by 3dB to 6dB.

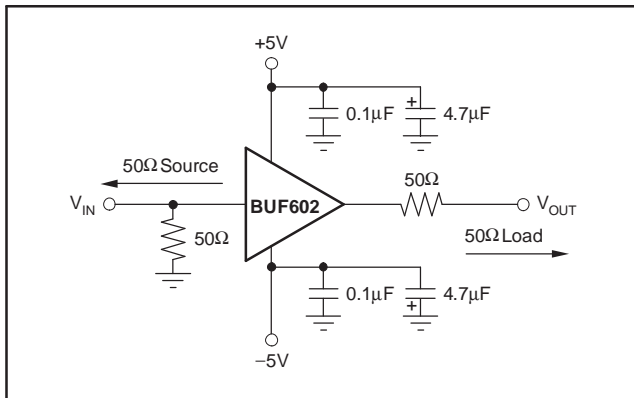

Figure 31. DC-Coupled, Bipolar Supply, Specification and Test Circuit

Figure 32 shows the AC-coupled, single-supply circuit configuration used as the basis of the +5V Electrical and Typical Characteristics. Though not a *rail-to-rail* design, the BUF602 requires minimal input and output voltage headroom compared to other very wideband buffers. It will deliver a 3V_{PP} output swing on a single +5V supply with greater than 400MHz bandwidth. The key requirement of broadband

single-supply operation of the BUF602 is to maintain output signal swings within the usable voltage ranges. The circuit of Figure 32 establishes an input midpoint bias using the internal midpoint reference. The input signal is then AC-coupled into this midpoint voltage bias. Again, on a single +5V supply, the output voltage can swing to within 1V of either supply pin while delivering more than 60mA output current. A demanding 100Ω load to a midpoint bias is used in this characterization circuit.

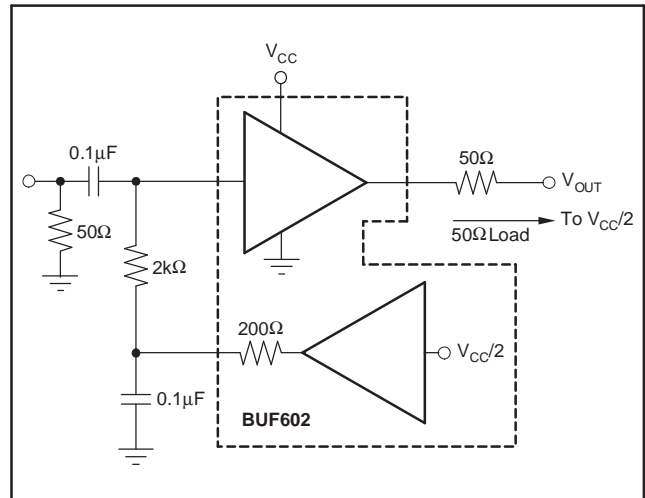

Figure 32. AC-Coupled, Single-Supply, Specification and Test Circuit

LOW-IMPEDANCE TRANSMISSION LINES

The most important equations and technical basics of transmission lines support the results found for the various drive circuits presented here. An ideal transmission medium with zero ohmic impedance would have inductance and capacitance distributed over the transmission cable. Both inductance and capacitance detract from the transmission quality of a line. Each input is connected with high-impedance to the line as in a daisy-chain or loop-through configuration, and each adds capacitance of at least a few picofarads. The typical transmission line impedance (Z_0) defines the line type. In Equation 1, the impedance is calculated by the square root of line inductance (L_T) divided by line capacitance (C_T):

$$Z_0 = \sqrt{\frac{L_T}{C_T}} \quad (1)$$

In the same manner, line inductance and capacitance determine the delay time of a transmission line as shown in Equation 2:

$$\tau = \sqrt{L_T \times C_T} \tag{2}$$

Typical values for Z_O are 240Ω for symmetrical traces and 75Ω or 50Ω for coaxial cables. Z_O sometimes decreases to 30Ω to 40Ω in high data rate bus systems for bus lines on printed circuit boards (PCBs). In general, the more complex a bus system is, the lower Z_O will be. Because it increases the capacitance of the transmission medium, a complex system lowers the typical line impedance, resulting in higher drive requirements for the line drivers used here.

Transmission lines are almost always terminated on the transmitter line and always terminated on the receiver side. Unterminated lines generate signal reflections that degrade the pulse fidelity. The driver circuit transmits the output voltage (V_{OUT}) over the line. The signal appears at the end of the line and will be reflected when not properly terminated. The reflected portion of V_{OUT} , called V_{REFL} , returns to the driver. The transmitted signal is the sum of the original signal V_{OUT} and the reflected V_{REFL} .

$$V_T = V_{OUT} + V_{REFL} \tag{3}$$

The magnitude of the reflected signal depends upon the typical line impedance (Z_O) and the value of the termination resistor Z_1 .

$$V_{REFL} = V_{OUT} \times \Gamma \tag{4}$$

Γ denotes the reflection factor and is described by Equation 5.

$$\Gamma = \sqrt{\frac{Z_1 - Z_O}{Z_1 + Z_O}} \tag{5}$$

Γ can vary from -1 to $+1$.

The conditions at the corner points of Equation 5 are as follows:

| | | | |
|----------------|---|---------------|-----------------------|
| $Z_O = Z_1$ | → | $\Gamma = 0$ | $V_{REFL} = 0$ |
| $Z_O = \infty$ | → | $\Gamma = -1$ | $V_{REFL} = -V_{OUT}$ |
| $Z_O = 0$ | → | $\Gamma = +1$ | $V_{REFL} = +V_{OUT}$ |

An unterminated driver circuit complicates the situation even more. V_{REFL} is reflected a second time on the driver side and wanders like a ping-pong ball back and forth over the line. When this happens, it is usually impossible to recover the output signal V_{OUT} on the receiver side.

The figure shown in Figure 33 makes use of the BUF602 as a line driver. The BUF602 exhibits high input impedance and low output impedance, making it ideal whenever a buffer is required.

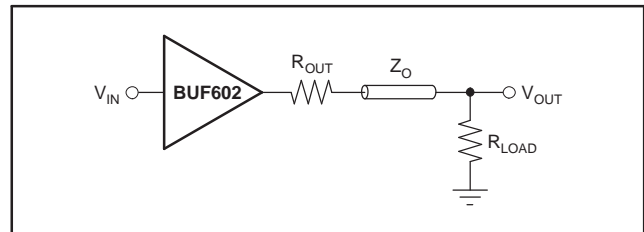

Figure 33. Typical Line Driver Circuit

SELF-BIASED, LOW-IMPEDANCE MID-SUPPLY VOLTAGE REFERENCE

Using the midpoint reference in conjunction with the BUF602 allows the creation of a low-impedance reference from DC to 250MHz.

The 0.1μF external capacitor is used in Figure 34 to filter the noise.

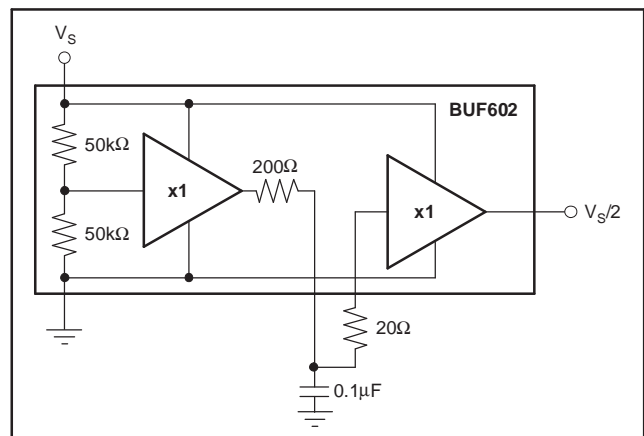

Figure 34. Self-Biased, Low Impedance Mid-Supply Voltage Reference

SELF-REFERENCED, AC-COUPLED WIDEBAND BUFFER

Whenever a high-speed AC-coupled buffer is required, you should consider the BUF602. One feature of the BUF602 is the mid-supply reference voltage, saving external components and power dissipation. A capacitor on the output of the mid-supply reference is recommended to bandlimit the noise contribution of the mid-supply reference voltage generated by the two 50kΩ internal resistors. This circuit is shown on the front page of the datasheet.

DESIGN-IN TOOLS

DEMONSTRATION FIXTURES

Two printed circuit boards (PCBs) are available to assist in the initial evaluation of circuit performance using the BUF602 in its two package options. Both of these are offered free of charge as unpopulated PCBs, delivered with a user's guide. The summary information for these fixtures is shown in [Table 1](#).

Table 1. Demonstration Fixtures by Package

| PRODUCT | PACKAGE | BOARD PART NUMBER | LITERATURE REQUEST NUMBER |
|------------|---------|-------------------|---------------------------|
| BUF602ID | SO-8 | DEM-BUF-SO-1A | SBAU118 |
| BUF602IDBV | SOT23-5 | DEM-BUF-SOT-1A | SBAU117 |

The demonstration fixtures can be requested at the Texas Instruments web site (www.ti.com) through the BUF602 product folder.

MACROMODELS AND APPLICATIONS SUPPORT

Computer simulation of circuit performance using SPICE is often useful when analyzing the performance of analog circuits and systems. This is particularly true for video and RF amplifier circuits where parasitic capacitance and inductance can have a major effect on circuit performance. A SPICE model for the BUF602 is available through the TI web site (www.ti.com). These models do a good job of predicting small-signal AC and transient performance under a wide variety of operating conditions. They do not do as well in predicting the harmonic distortion or dG/dP characteristics. These models do not attempt to distinguish between package types in their small-signal AC performance.

OUTPUT CURRENT AND VOLTAGE

The BUF602 provides output voltage and current capabilities that are not usually found in wideband buffers. Under no-load conditions at +25°C, the output voltage typically swings closer than 1.2V to either supply rail; the +25°C swing limit is within 1.2V of either rail. Into a 15Ω load (the minimum tested load), it is tested to deliver more than ±60mA.

The specifications described above, though familiar in the industry, consider voltage and current limits separately. In many applications, it is the *voltage × current*, or V-I product, which is more relevant to circuit operation. Refer to the *Buffer Output Voltage and Current Limitations* plot ([Figure 16](#)) in the Typical Characteristics. The X and Y axes of this graph show the zero-voltage output current limit and the zero-current output voltage limit, respectively. The four quadrants give a more detailed view of the

BUF602 output drive capabilities, noting that the graph is bounded by a *Safe Operating Area* of 1W maximum internal power dissipation. Superimposing resistor load lines onto the plot shows that the BUF602 can drive ±3V into 25Ω or ±3.5V into 50Ω without exceeding the output capabilities or the 1W dissipation limit.

The minimum specified output voltage and current over-temperature are set by worst-case simulations at the cold temperature extreme. Only at cold startup will the output current and voltage decrease to the numbers shown in the Electrical Characteristic tables. As the output transistors deliver power, the junction temperatures will increase, decreasing both V_{BE} (increasing the available output voltage swing) and increasing the current gains (increasing the available output current). In steady-state operation, the available output voltage and current will always be greater than that shown in the over-temperature specifications, since the output stage junction temperatures will be higher than the minimum specified operating ambient.

For a buffer, the noise model is shown in [Figure 35](#). [Equation 6](#) shows the general form for the output noise voltage using the terms shown in [Figure 35](#).

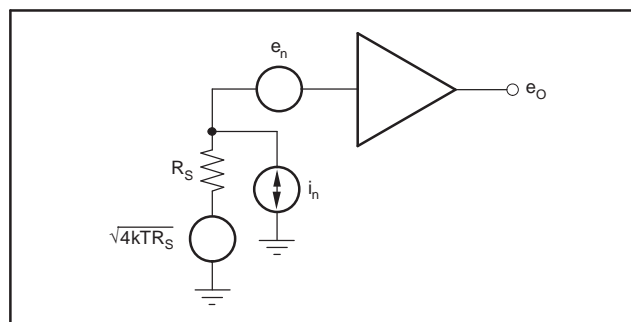

Figure 35. Buffer Noise Analysis Model

$$e_o = \sqrt{e_n^2 + (i_n R_s)^2 + 4kTR_s} \frac{nV}{\sqrt{\text{Hz}}} \quad (6)$$

THERMAL ANALYSIS

Due to the high output power capability of the BUF602, heatsinking or forced airflow may be required under extreme operating conditions. Maximum desired junction temperature will set the maximum allowed internal power dissipation as described below. In no case should the maximum junction temperature be allowed to exceed 150°C.

Operating junction temperature (T_J) is given by $T_A + P_D \times \theta_{JA}$. The total internal power dissipation (P_D) is the sum of quiescent power (P_{DQ}) and additional power dissipated in the output stage (P_{DL}) to deliver load power. Quiescent power is simply the specified no-load supply current times the total supply voltage

across the part. P_{DL} will depend on the required output signal and load but would, for a grounded resistive load, be at a maximum when the output is fixed at a voltage equal to 1/2 of either supply voltage (for equal bipolar supplies). Under this condition, $P_{DL} = V_S^2/(4 \times R_L)$.

Note that it is the power in the output stage and not into the load that determines internal power dissipation.

As a worst-case example, compute the maximum T_J using a BUF602IDBV in the circuit on the front page operating at the maximum specified ambient temperature of +85°C and driving a grounded 20Ω load.

$$P_D = 10V \times 5.8mA + 5^2/(4 \times 20\Omega) = 370.5mW$$

$$\text{Maximum } T_J = +85^\circ\text{C} + (0.37W \times 150^\circ\text{C/W}) = 141^\circ\text{C}.$$

Although this is still below the specified maximum junction temperature, system reliability considerations may require lower tested junction temperatures. The highest possible internal dissipation will occur if the load requires current to be forced into the output for positive output voltages or sourced from the output for negative output voltages. This puts a high current through a large internal voltage drop in the output transistors. The output V-I plot (Figure 16) shown in the Typical Characteristics include a boundary for 1W maximum internal power dissipation under these conditions.

BOARD LAYOUT GUIDELINES

Achieving optimum performance with a high-frequency amplifier like the BUF602 requires careful attention to board layout parasitics and external component types. Recommendations that will optimize performance include:

a) Minimize parasitic capacitance to any AC ground for all of the signal I/O pins. Parasitic capacitance on the output pins can cause instability: on the noninverting input, it can react with the source impedance to cause unintentional bandlimiting. To reduce unwanted capacitance, a window around the signal I/O pins should be opened in all of the ground and power planes around those pins. Otherwise, ground and power planes should be unbroken elsewhere on the board.

b) Minimize the distance (< 0.25") from the power-supply pins to high-frequency 0.1μF decoupling capacitors. At the device pins, the ground and power-plane layout should not be in close proximity to the signal I/O pins. Avoid narrow power and ground traces to minimize inductance between the pins and the decoupling capacitors. The power-supply connections should always be decoupled with these capacitors. An optional supply decoupling capacitor (0.1μF) across the two power supplies (for bipolar operation) will improve 2nd-harmonic distortion performance. Larger (2.2μF to 6.8μF) decoupling capacitors, effective at lower frequency, should also be used on the main supply pins. These may be placed somewhat farther from the device and may be shared among several devices in the same area of the PCB.

c) Careful selection and placement of external components will preserve the high-frequency performance of the BUF602. Resistors should be a very low reactance type. Surface-mount resistors work best and allow a tighter overall layout. Metal film or carbon composition, axially-leaded resistors can also provide good high-frequency performance. Again, keep their leads and PCB traces as short as possible. Never use wirewound type resistors in a high-frequency application.

d) Connections to other wideband devices on the board may be made with short, direct traces or through onboard transmission lines. For short connections, consider the trace and the input to the next device as a lumped capacitive load. Relatively wide traces (50mils to 100mils) should be used, preferably with ground and power planes opened up around them. If a long trace is required, and the 6dB signal loss intrinsic to a doubly-terminated transmission line is acceptable, implement a matched impedance transmission line using microstrip or stripline techniques (consult an ECL design handbook for microstrip and stripline layout techniques). A 50Ω environment is normally not necessary on board, and in fact, a higher impedance environment will improve distortion as shown in the distortion versus load plots.

e) Socketing a high-speed part like the BUF602 is not recommended. The additional lead length and pin-to-pin capacitance introduced by the socket can create an extremely troublesome parasitic network that makes it almost impossible to achieve a smooth, stable frequency response. Best results are obtained by soldering the BUF602 onto the board.

INPUT AND ESD PROTECTION

The BUF602 is built using a very high-speed complementary bipolar process. The internal junction breakdown voltages are relatively low for these very small geometry devices. These breakdowns are reflected in the *Absolute Maximum Ratings* table. All device pins are protected with internal ESD protection diodes to the power supplies as shown in [Figure 36](#).

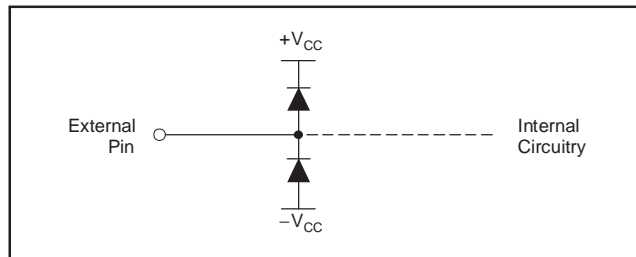

Figure 36. Internal ESD Protection

These diodes provide moderate protection to input overdrive voltages above the supplies as well. The protection diodes can typically support 30mA continuous current. Where higher currents are possible (for example, in systems with $\pm 15V$ supply parts driving into the BUF602), current-limiting series resistors should be added into the two inputs. Keep these resistor values as low as possible since high values degrade both noise performance and frequency response.

Revision History

Changes from Revision A (August 2006) to Revision B **Page**

- Changed storage temperature range rating in *Absolute Maximum Ratings* table from -40°C to $+125^{\circ}\text{C}$ to -65°C to $+125^{\circ}\text{C}$ 2
-

Changes from Original (October 2005) to Revision A **Page**

- Added [Figure 17](#). 10
 - Added [Figure 18](#). 10
 - Changed [Demonstration Fixtures](#) title and text..... 15
-

PACKAGING INFORMATION

| Orderable Device | Status ⁽¹⁾ | Package Type | Package Drawing | Pins | Package Qty | Eco Plan ⁽²⁾ | Lead/Ball Finish | MSL Peak Temp ⁽³⁾ |
|------------------|-----------------------|--------------|-----------------|------|-------------|-------------------------|------------------|------------------------------|
| BUF602ID | ACTIVE | SOIC | D | 8 | 75 | Green (RoHS & no Sb/Br) | CU NIPDAU | Level-2-260C-1 YEAR |
| BUF602IDBVR | ACTIVE | SOT-23 | DBV | 5 | 3000 | Green (RoHS & no Sb/Br) | CU NIPDAU | Level-2-260C-1 YEAR |
| BUF602IDBVRG4 | ACTIVE | SOT-23 | DBV | 5 | 3000 | Green (RoHS & no Sb/Br) | CU NIPDAU | Level-2-260C-1 YEAR |
| BUF602IDBVT | ACTIVE | SOT-23 | DBV | 5 | 250 | Green (RoHS & no Sb/Br) | CU NIPDAU | Level-2-260C-1 YEAR |
| BUF602IDBVTG4 | ACTIVE | SOT-23 | DBV | 5 | 250 | Green (RoHS & no Sb/Br) | CU NIPDAU | Level-2-260C-1 YEAR |
| BUF602IDG4 | ACTIVE | SOIC | D | 8 | 75 | Green (RoHS & no Sb/Br) | CU NIPDAU | Level-2-260C-1 YEAR |
| BUF602IDR | ACTIVE | SOIC | D | 8 | 2500 | Green (RoHS & no Sb/Br) | CU NIPDAU | Level-2-260C-1 YEAR |
| BUF602IDRG4 | ACTIVE | SOIC | D | 8 | 2500 | Green (RoHS & no Sb/Br) | CU NIPDAU | Level-2-260C-1 YEAR |

⁽¹⁾ The marketing status values are defined as follows:

ACTIVE: Product device recommended for new designs.

LIFEBUY: TI has announced that the device will be discontinued, and a lifetime-buy period is in effect.

NRND: Not recommended for new designs. Device is in production to support existing customers, but TI does not recommend using this part in a new design.

PREVIEW: Device has been announced but is not in production. Samples may or may not be available.

OBSOLETE: TI has discontinued the production of the device.

⁽²⁾ Eco Plan - The planned eco-friendly classification: Pb-Free (RoHS), Pb-Free (RoHS Exempt), or Green (RoHS & no Sb/Br) - please check <http://www.ti.com/productcontent> for the latest availability information and additional product content details.

TBD: The Pb-Free/Green conversion plan has not been defined.

Pb-Free (RoHS): TI's terms "Lead-Free" or "Pb-Free" mean semiconductor products that are compatible with the current RoHS requirements for all 6 substances, including the requirement that lead not exceed 0.1% by weight in homogeneous materials. Where designed to be soldered at high temperatures, TI Pb-Free products are suitable for use in specified lead-free processes.

Pb-Free (RoHS Exempt): This component has a RoHS exemption for either 1) lead-based flip-chip solder bumps used between the die and package, or 2) lead-based die adhesive used between the die and leadframe. The component is otherwise considered Pb-Free (RoHS compatible) as defined above.

Green (RoHS & no Sb/Br): TI defines "Green" to mean Pb-Free (RoHS compatible), and free of Bromine (Br) and Antimony (Sb) based flame retardants (Br or Sb do not exceed 0.1% by weight in homogeneous material)

⁽³⁾ MSL, Peak Temp. -- The Moisture Sensitivity Level rating according to the JEDEC industry standard classifications, and peak solder temperature.

Important Information and Disclaimer: The information provided on this page represents TI's knowledge and belief as of the date that it is provided. TI bases its knowledge and belief on information provided by third parties, and makes no representation or warranty as to the accuracy of such information. Efforts are underway to better integrate information from third parties. TI has taken and continues to take reasonable steps to provide representative and accurate information but may not have conducted destructive testing or chemical analysis on incoming materials and chemicals. TI and TI suppliers consider certain information to be proprietary, and thus CAS numbers and other limited information may not be available for release.

In no event shall TI's liability arising out of such information exceed the total purchase price of the TI part(s) at issue in this document sold by TI to Customer on an annual basis.

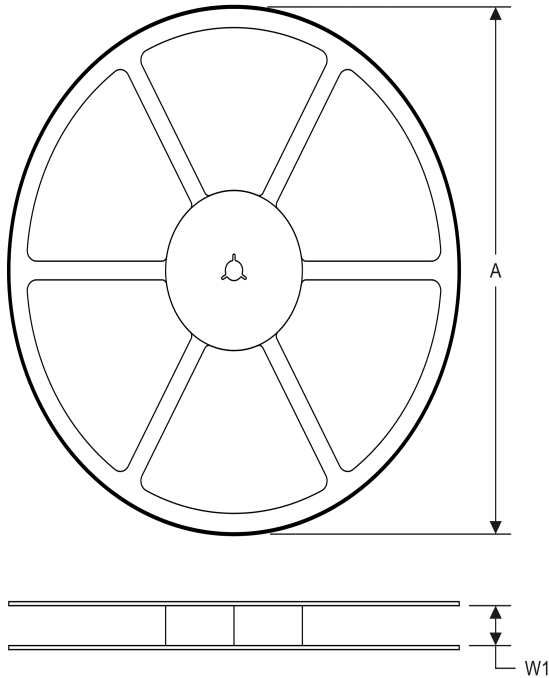
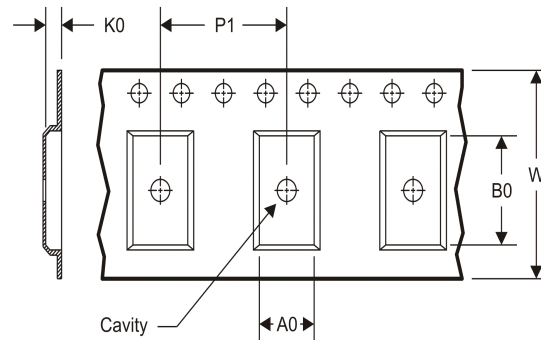
TAPE AND REEL INFORMATION
REEL DIMENSIONS

TAPE DIMENSIONS

| | |
|----|-----------------------------------------------------------|
| A0 | Dimension designed to accommodate the component width |
| B0 | Dimension designed to accommodate the component length |
| K0 | Dimension designed to accommodate the component thickness |
| W | Overall width of the carrier tape |
| P1 | Pitch between successive cavity centers |

TAPE AND REEL INFORMATION

*All dimensions are nominal

| Device | Package Type | Package Drawing | Pins | SPQ | Reel Diameter (mm) | Reel Width W1 (mm) | A0 (mm) | B0 (mm) | K0 (mm) | P1 (mm) | W (mm) | Pin1 Quadrant |
|-------------|--------------|-----------------|------|------|--------------------|--------------------|---------|---------|---------|---------|--------|---------------|
| BUF602IDBVR | SOT-23 | DBV | 5 | 3000 | 180.0 | 8.4 | 3.2 | 3.1 | 1.39 | 4.0 | 8.0 | Q3 |
| BUF602IDBVT | SOT-23 | DBV | 5 | 250 | 180.0 | 8.4 | 3.2 | 3.1 | 1.39 | 4.0 | 8.0 | Q3 |
| BUF602IDR | SOIC | D | 8 | 2500 | 330.0 | 12.4 | 6.4 | 5.2 | 2.1 | 8.0 | 12.0 | Q1 |

TAPE AND REEL BOX DIMENSIONS

*All dimensions are nominal

| Device | Package Type | Package Drawing | Pins | SPQ | Length (mm) | Width (mm) | Height (mm) |
|-------------|--------------|-----------------|------|------|-------------|------------|-------------|
| BUF602IDBVR | SOT-23 | DBV | 5 | 3000 | 210.0 | 185.0 | 35.0 |
| BUF602IDBVT | SOT-23 | DBV | 5 | 250 | 210.0 | 185.0 | 35.0 |
| BUF602IDR | SOIC | D | 8 | 2500 | 367.0 | 367.0 | 35.0 |

DBV (R-PDSO-G5)

PLASTIC SMALL-OUTLINE PACKAGE

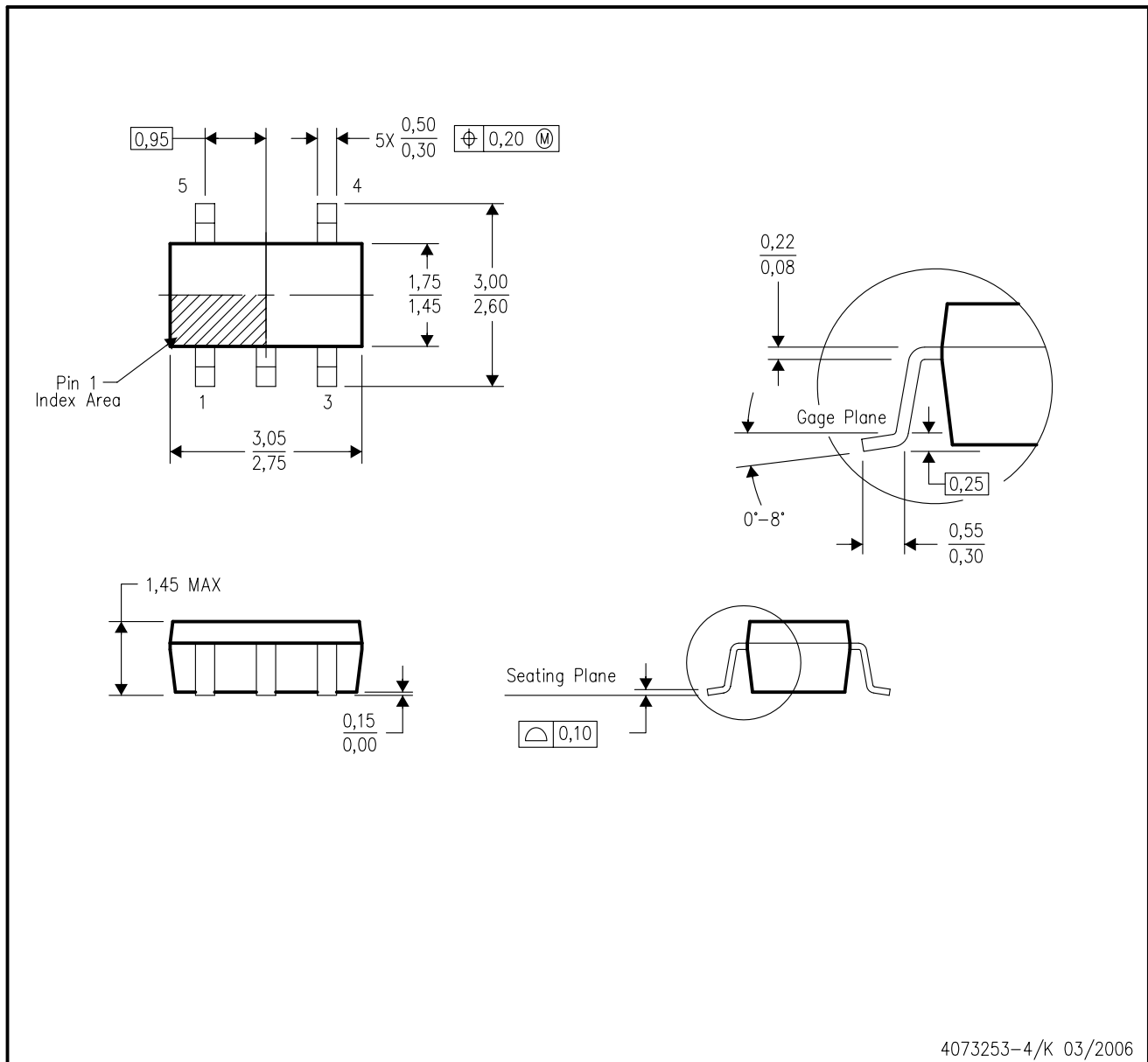

- NOTES:
- A. All linear dimensions are in millimeters.
 - B. This drawing is subject to change without notice.
 - C. Body dimensions do not include mold flash or protrusion. Mold flash and protrusion shall not exceed 0.15 per side.
 - D. Falls within JEDEC MO-178 Variation AA.

DBV (R-PDSO-G5)

PLASTIC SMALL OUTLINE



- NOTES:
- A. All linear dimensions are in millimeters.
 - B. This drawing is subject to change without notice.
 - C. Customers should place a note on the circuit board fabrication drawing not to alter the center solder mask defined pad.
 - D. Publication IPC-7351 is recommended for alternate designs.
 - E. Laser cutting apertures with trapezoidal walls and also rounding corners will offer better paste release. Customers should contact their board assembly site for stencil design recommendations. Example stencil design based on a 50% volumetric metal load solder paste. Refer to IPC-7525 for other stencil recommendations.

D (R-PDSO-G8)

PLASTIC SMALL OUTLINE

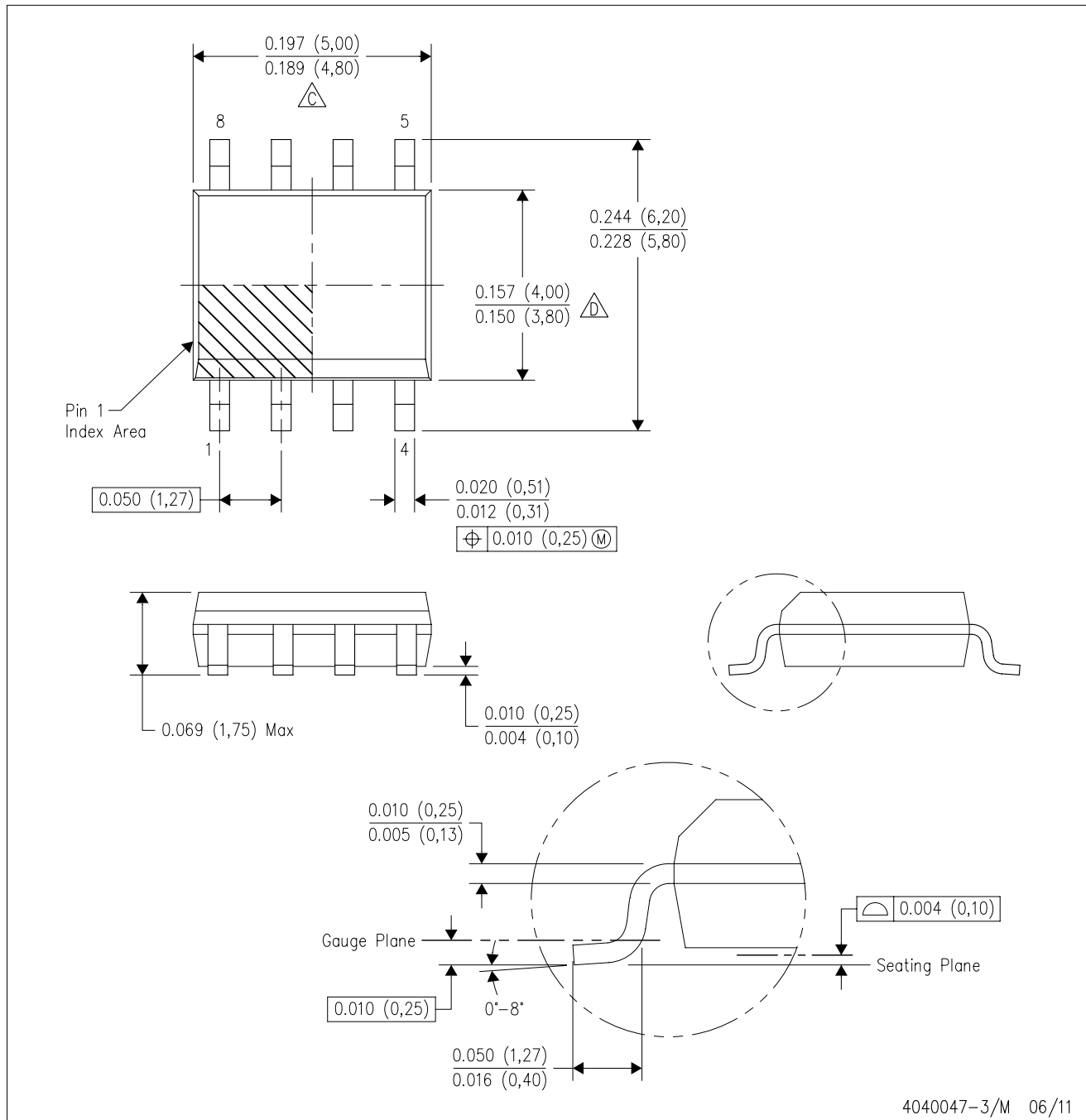

D (R-PDSO-G8)

PLASTIC SMALL OUTLINE

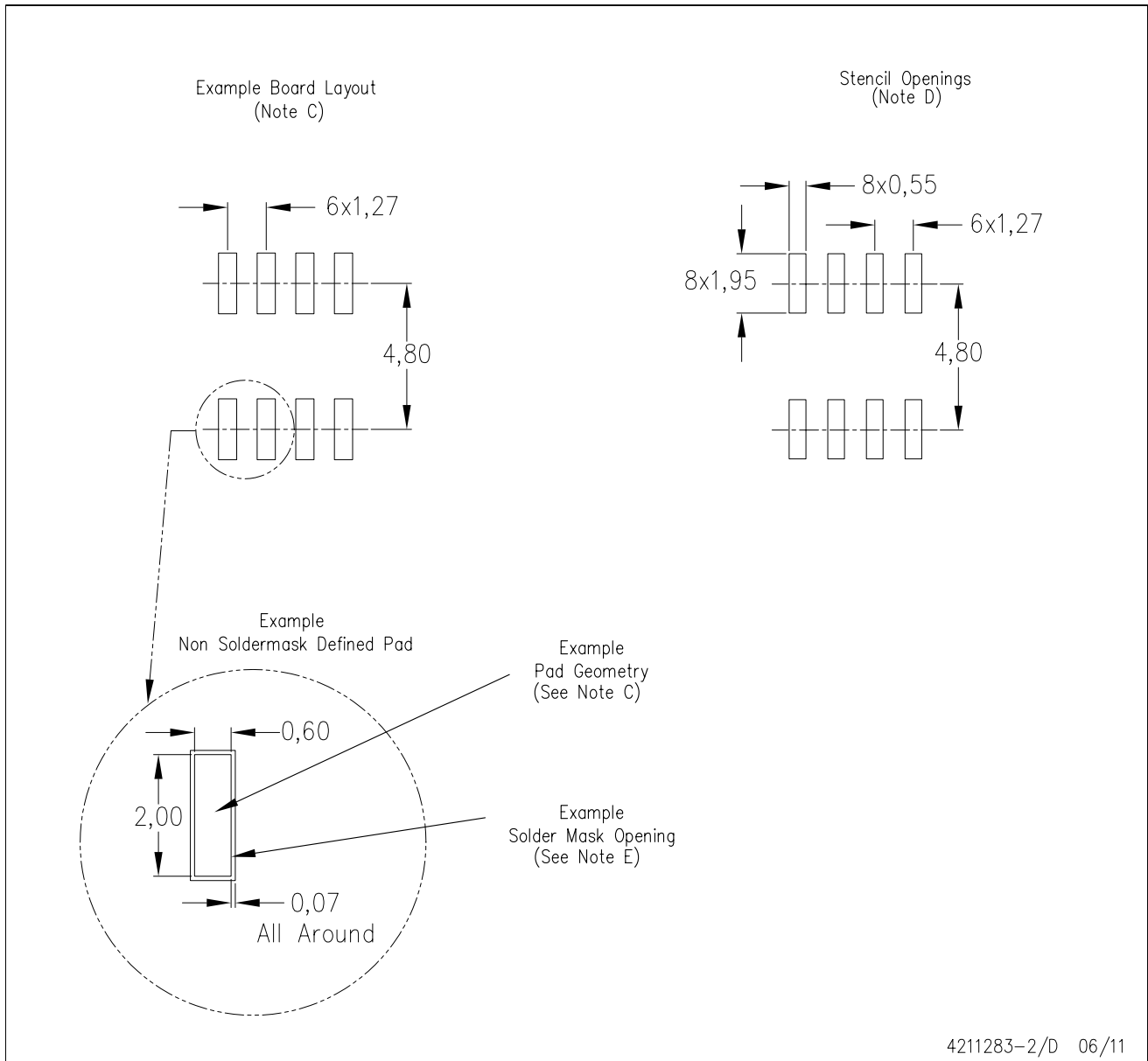

- NOTES:
- All linear dimensions are in millimeters.
 - This drawing is subject to change without notice.
 - Publication IPC-7351 is recommended for alternate designs.
 - Laser cutting apertures with trapezoidal walls and also rounding corners will offer better paste release. Customers should contact their board assembly site for stencil design recommendations. Refer to IPC-7525 for other stencil recommendations.
 - Customers should contact their board fabrication site for solder mask tolerances between and around signal pads.

IMPORTANT NOTICE

Texas Instruments Incorporated and its subsidiaries (TI) reserve the right to make corrections, enhancements, improvements and other changes to its semiconductor products and services per JESD46C and to discontinue any product or service per JESD48B. Buyers should obtain the latest relevant information before placing orders and should verify that such information is current and complete. All semiconductor products (also referred to herein as "components") are sold subject to TI's terms and conditions of sale supplied at the time of order acknowledgment.

TI warrants performance of its components to the specifications applicable at the time of sale, in accordance with the warranty in TI's terms and conditions of sale of semiconductor products. Testing and other quality control techniques are used to the extent TI deems necessary to support this warranty. Except where mandated by applicable law, testing of all parameters of each component is not necessarily performed.

TI assumes no liability for applications assistance or the design of Buyers' products. Buyers are responsible for their products and applications using TI components. To minimize the risks associated with Buyers' products and applications, Buyers should provide adequate design and operating safeguards.

TI does not warrant or represent that any license, either express or implied, is granted under any patent right, copyright, mask work right, or other intellectual property right relating to any combination, machine, or process in which TI components or services are used. Information published by TI regarding third-party products or services does not constitute a license to use such products or services or a warranty or endorsement thereof. Use of such information may require a license from a third party under the patents or other intellectual property of the third party, or a license from TI under the patents or other intellectual property of TI.

Reproduction of significant portions of TI information in TI data books or data sheets is permissible only if reproduction is without alteration and is accompanied by all associated warranties, conditions, limitations, and notices. TI is not responsible or liable for such altered documentation. Information of third parties may be subject to additional restrictions.

Resale of TI components or services with statements different from or beyond the parameters stated by TI for that component or service voids all express and any implied warranties for the associated TI component or service and is an unfair and deceptive business practice. TI is not responsible or liable for any such statements.

Buyer acknowledges and agrees that it is solely responsible for compliance with all legal, regulatory and safety-related requirements concerning its products, and any use of TI components in its applications, notwithstanding any applications-related information or support that may be provided by TI. Buyer represents and agrees that it has all the necessary expertise to create and implement safeguards which anticipate dangerous consequences of failures, monitor failures and their consequences, lessen the likelihood of failures that might cause harm and take appropriate remedial actions. Buyer will fully indemnify TI and its representatives against any damages arising out of the use of any TI components in safety-critical applications.

In some cases, TI components may be promoted specifically to facilitate safety-related applications. With such components, TI's goal is to help enable customers to design and create their own end-product solutions that meet applicable functional safety standards and requirements. Nonetheless, such components are subject to these terms.

No TI components are authorized for use in FDA Class III (or similar life-critical medical equipment) unless authorized officers of the parties have executed a special agreement specifically governing such use.

Only those TI components which TI has specifically designated as military grade or "enhanced plastic" are designed and intended for use in military/aerospace applications or environments. Buyer acknowledges and agrees that any military or aerospace use of TI components which have **not** been so designated is solely at the Buyer's risk, and that Buyer is solely responsible for compliance with all legal and regulatory requirements in connection with such use.

TI has specifically designated certain components which meet ISO/TS16949 requirements, mainly for automotive use. Components which have not been so designated are neither designed nor intended for automotive use; and TI will not be responsible for any failure of such components to meet such requirements.

Products

| | |
|------------------------|--------------------------------------------------------------------------------------|
| Audio | www.ti.com/audio |
| Amplifiers | amplifier.ti.com |
| Data Converters | dataconverter.ti.com |
| DLP® Products | www.dlp.com |
| DSP | dsp.ti.com |
| Clocks and Timers | www.ti.com/clocks |
| Interface | interface.ti.com |
| Logic | logic.ti.com |
| Power Mgmt | power.ti.com |
| Microcontrollers | microcontroller.ti.com |
| RFID | www.ti-rfid.com |
| OMAP Mobile Processors | www.ti.com/omap |
| Wireless Connectivity | www.ti.com/wirelessconnectivity |

Applications

| | |
|-------------------------------|------------------------------------------------------------------------------------------|
| Automotive and Transportation | www.ti.com/automotive |
| Communications and Telecom | www.ti.com/communications |
| Computers and Peripherals | www.ti.com/computers |
| Consumer Electronics | www.ti.com/consumer-apps |
| Energy and Lighting | www.ti.com/energy |
| Industrial | www.ti.com/industrial |
| Medical | www.ti.com/medical |
| Security | www.ti.com/security |
| Space, Avionics and Defense | www.ti.com/space-avionics-defense |
| Video and Imaging | www.ti.com/video |

TI E2E Community e2e.ti.com