

# CDC339 CLOCK DRIVER WITH 3-STATE OUTPUTS

SCAS331 – DECEMBER 1992 – REVISED MARCH 1994

- Low Output Skew, Low Pulse Skew for Clock-Distribution and Clock-Generation Applications
- TTL-Compatible Inputs and Outputs
- Distributes One Clock Input to Eight Outputs
  - Four Same-Frequency Outputs
  - Four Half-Frequency Outputs
- Distributed  $V_{CC}$  and Ground Pins Reduce Switching Noise
- High-Drive Outputs ( $-48\text{-mA } I_{OH}$ ,  $48\text{-mA } I_{OL}$ )
- State-of-the-Art EPIC-IIB™ BiCMOS Design Significantly Reduces Power Dissipation
- Package Options Include Plastic Small-Outline (DW) and Shrink Small-Outline (DB) Packages

DB OR DW PACKAGE  
(TOP VIEW)

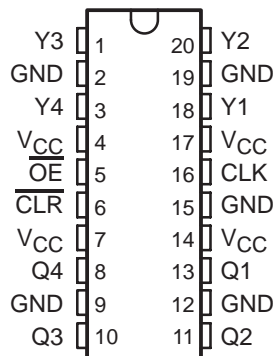

## description

The CDC339 is a high-performance, low-skew clock driver. It is specifically designed for applications requiring synchronized output signals at both the primary clock frequency and one-half the primary clock frequency. The four Y outputs switch in phase and at the same frequency as the clock (CLK) input. The four Q outputs switch at one-half the frequency of CLK.

When the output-enable ( $\overline{OE}$ ) input is low and the clear ( $\overline{CLR}$ ) input is high, the Y outputs follow CLK and the Q outputs toggle on low-to-high transitions of CLK. Taking CLR low asynchronously resets the Q outputs to the low level. When  $\overline{OE}$  is high, the outputs are in the high-impedance state.

The CDC339 is characterized for operation from  $-40^{\circ}\text{C}$  to  $85^{\circ}\text{C}$ .

FUNCTION TABLE

INPUTS			OUTPUTS	
$\overline{OE}$	$\overline{CLR}$	CLK	Y1–Y4	Q1–Q4
H	X	X	Z	Z
L	L	L	L	L
L	L	H	H	L
L	H	L	L	$Q_0^{\dagger}$
L	H	$\uparrow$	H	$\overline{Q_0}^{\dagger}$

† The level of the Q outputs before the indicated steady-state input conditions were established.



Please be aware that an important notice concerning availability, standard warranty, and use in critical applications of Texas Instruments semiconductor products and disclaimers thereto appears at the end of this data sheet.

EPIC-IIB is a trademark of Texas Instruments Incorporated.

PRODUCTION DATA information is current as of publication date. Products conform to specifications per the terms of Texas Instruments standard warranty. Production processing does not necessarily include testing of all parameters.

**TEXAS  
INSTRUMENTS**

POST OFFICE BOX 655303 • DALLAS, TEXAS 75265

Copyright © 1994, Texas Instruments Incorporated

# CDC339 CLOCK DRIVER WITH 3-STATE OUTPUTS

SCAS331 – DECEMBER 1992 – REVISED MARCH 1994

## logic symbol†

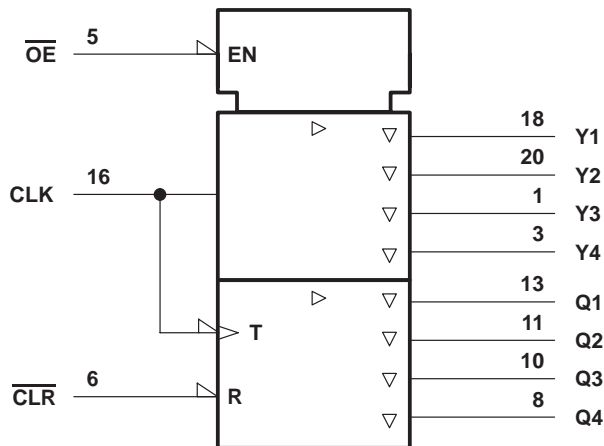

† This symbol is in accordance with ANSI/IEEE Std 91-1984 and IEC Publication 617-12.

## logic diagram (positive logic)

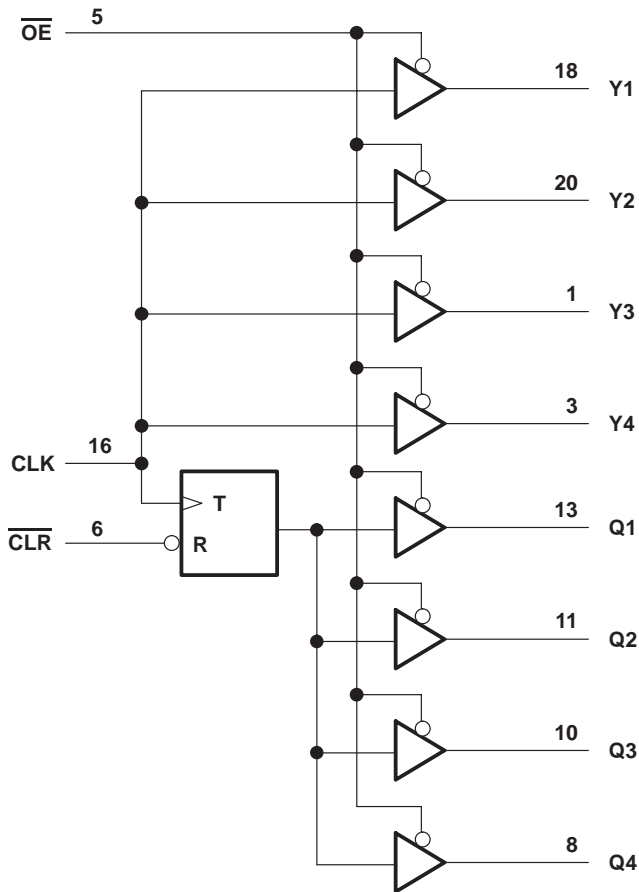

## absolute maximum ratings over operating free-air temperature range (unless otherwise noted)‡

Supply voltage range, $V_{CC}$ .....	-0.5 V to 7 V
Input voltage range, $V_I$ (see Note 1) .....	-0.5 V to 7 V
Voltage range applied to any output in the disabled or power-off state, $V_O$ .....	-0.5 V to 5.5 V
Current into any output in the low state, $I_O$ .....	96 mA
Input clamp current, $I_{IK}$ ( $V_I < 0$ ) .....	-18 mA
Output clamp current, $I_{OK}$ ( $V_O < 0$ ) .....	-50 mA
Maximum power dissipation at $T_A = 55^\circ\text{C}$ (in still air) (see Note 2): DB package .....	0.6 W
..... DW package .....	1.6 W
Storage temperature range, $T_{stg}$ .....	-65°C to 150°C

‡ Stresses beyond those listed under "absolute maximum ratings" may cause permanent damage to the device. These are stress ratings only, and functional operation of the device at these or any other conditions beyond those indicated under "recommended operating conditions" is not implied. Exposure to absolute-maximum-rated conditions for extended periods may affect device reliability.

NOTES: 1. The input and output negative-voltage ratings may be exceeded if the input and output clamp-current ratings are observed.  
2. The maximum package power dissipation is calculated using a junction temperature of 150°C and a board trace length of 750 mils. For more information, refer to the *Package Thermal Considerations* application note in the 1994 *ABT Advanced BiCMOS Technology Data Book*, literature number SCBD002B.

# CDC339 CLOCK DRIVER WITH 3-STATE OUTPUTS

SCAS331 – DECEMBER 1992 – REVISED MARCH 1994

## recommended operating conditions (see Note 3)

		MIN	MAX	UNIT
$V_{CC}$	Supply voltage	4.75	5.25	V
$V_{IH}$	High-level input voltage	2		V
$V_{IL}$	Low-level input voltage		0.8	V
$V_I$	Input voltage	0	$V_{CC}$	V
$I_{OH}$	High-level output current		-48	mA
$I_{OL}$	Low-level output current		48	mA
$f_{clock}$	Input clock frequency		80	MHz
$T_A$	Operating free-air temperature	-40	85	°C

NOTE 3: Unused pins (input or I/O) must be held high or low.

## electrical characteristics over recommended operating free-air temperature range (unless otherwise noted)

PARAMETER	TEST CONDITIONS		MIN	TYP†	MAX	UNIT
$V_{IK}$	$V_{CC} = 4.75$ V,	$I_I = -18$ mA			-1.2	V
$V_{OH}$	$V_{CC} = 4.75$ V,	$I_{OH} = -48$ mA	2			V
$V_{OL}$	$V_{CC} = 4.75$ V,	$I_{OL} = 48$ mA			0.5	V
$I_{IH}$	$V_{CC} = 5.25$ V,	$V_I = 2.7$ V			50	μA
$I_{IL}$	$V_{CC} = 5.25$ V,	$V_I = 0.5$ V			-50	μA
$I_{OZ}$	$V_{CC} = 5.25$ V,	$V_O = 2.7$ V or 0.5 V			±50	μA
$I_{O‡}$	$V_{CC} = 5.25$ V,	$V_O = 2.5$ V	-50		-180	mA
$I_{CC}$	$V_{CC} = 5.25$ V, $V_I = V_{CC}$ or GND	$I_O = 0$ ,	Outputs high		70	mA
			Outputs low		85	
			Outputs disabled		70	
$C_i$	$V_I = 2.5$ V or 0.5 V				3	pF
$C_o$	$V_O = 2.5$ V or 0.5 V				8	pF

† All typical values are at  $V_{CC} = 5$  V,  $T_A = 25^\circ\text{C}$ .

‡ Not more than one output should be tested at a time, and the duration of the test should not exceed one second.

## timing requirements over recommended ranges of supply voltage and operating free-air temperature

		MIN	MAX	UNIT	
$f_{clock}$	Clock frequency		80	MHz	
$t_w$	Pulse duration	$\overline{\text{CLR}}$ low	4	ns	
		CLK low	4		
		CLK high	4		
$t_{su}$	Setup time	$\overline{\text{CLR}}$ inactive before $\text{CLK}\uparrow$		2	ns
	Clock duty cycle	40%	60%		

**CDC339**  
**CLOCK DRIVER**  
**WITH 3-STATE OUTPUTS**

SCAS331 – DECEMBER 1992 – REVISED MARCH 1994

switching characteristics over recommended ranges of supply voltage and operating free-air temperature (see Figures 1 and 2)

PARAMETER	FROM (INPUT)	TO (OUTPUT)	MIN	TYP†	MAX	UNIT
$f_{max}$			80			MHz
$t_{PLH}$	CLK	Any Y or Q	3		9	ns
$t_{PHL}$			3		9	
$t_{PHL}$	$\overline{CLR}$	Any Q	4		9	ns
$t_{PZH}$	$\overline{OE}$	Any Y or Q	2		7	ns
$t_{PZL}$			3		7	
$t_{PHZ}$	$\overline{OE}$	Any Y or Q	2		7	ns
$t_{PLZ}$			2		7	
$t_{sk(o)}$	CLK↑	Y↑			0.75	ns
		Q↑			0.9	
		Y↑ and Q↑			0.9	
$t_r$				0.9		ns
$t_f$				0.7		ns

† All typical values are at  $V_{CC} = 5\text{ V}$ ,  $T_A = 25^\circ\text{C}$ .

**PARAMETER MEASUREMENT INFORMATION**

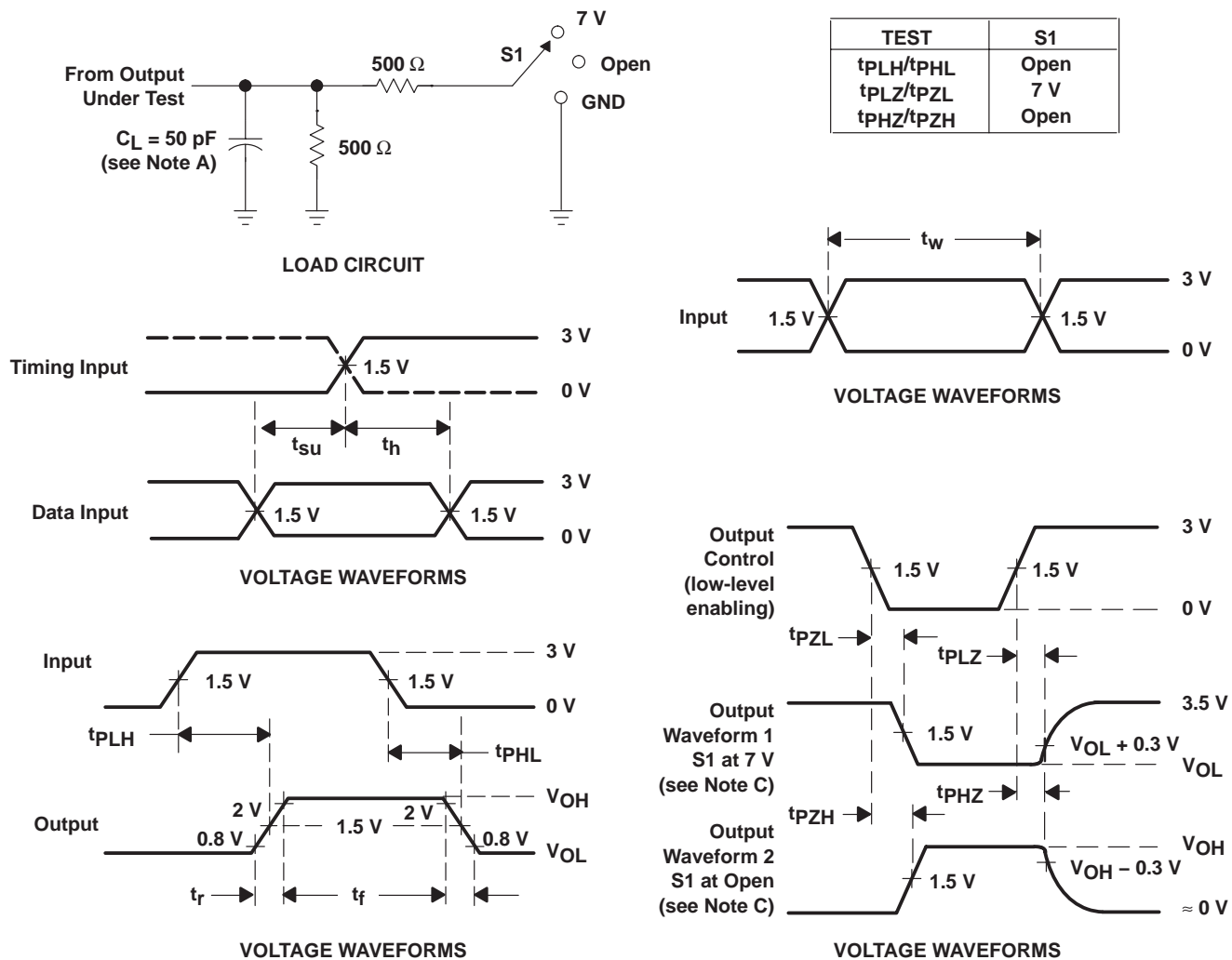

- NOTES: A.  $C_L$  includes probe and jig capacitance.  
 B. All input pulses are supplied by generators having the following characteristics:  $PRR \leq 10 \text{ MHz}$ ,  $Z_O = 50 \Omega$ ,  $t_r \leq 2.5 \text{ ns}$ ,  $t_f \leq 2.5 \text{ ns}$ .  
 C. Waveform 1 is for an output with internal conditions such that the output is low except when disabled by the output control. Waveform 2 is for an output with internal conditions such that the output is high except when disabled by the output control.  
 D. The outputs are measured one at a time with one transition per measurement.

**Figure 1. Load Circuit and Voltage Waveforms**

**CDC339  
CLOCK DRIVER  
WITH 3-STATE OUTPUTS**

SCAS331 – DECEMBER 1992 – REVISED MARCH 1994

**PARAMETER MEASUREMENT INFORMATION**

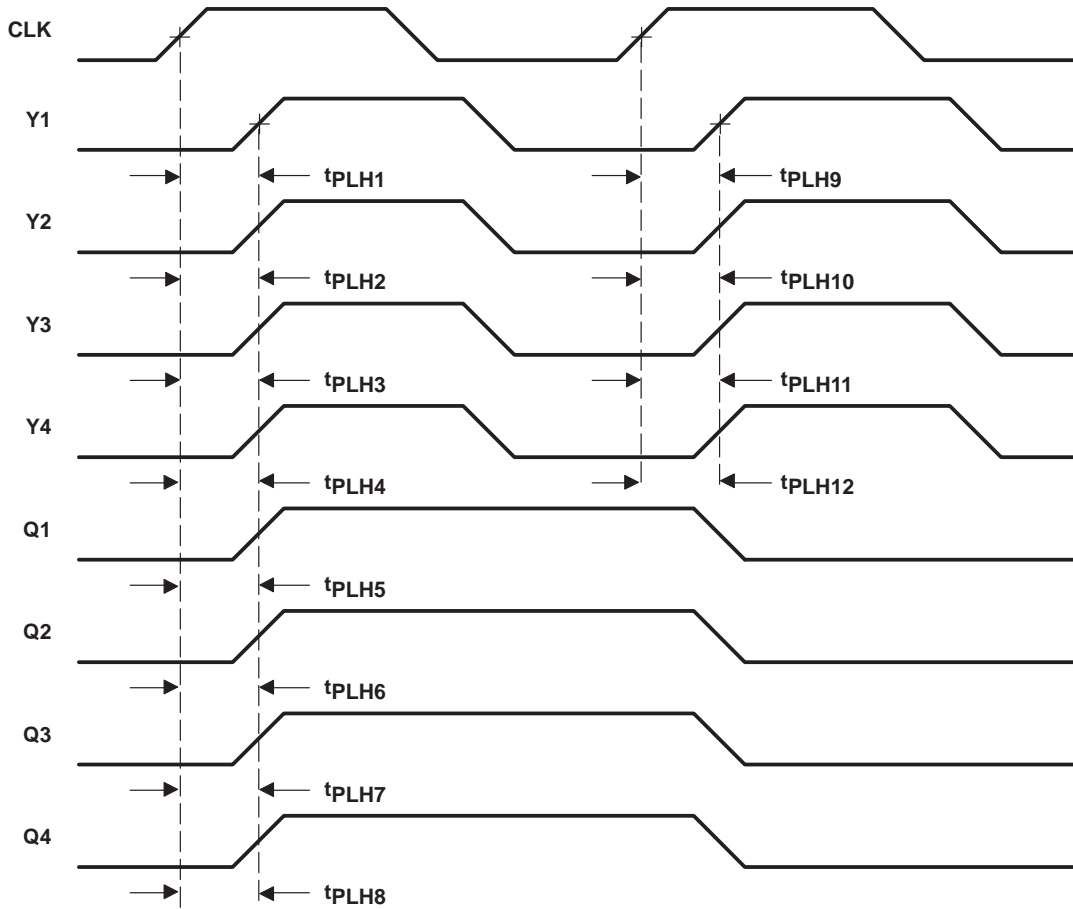

- NOTES: A. Output skew,  $t_{sk(o)}$ , from  $CLK\uparrow$  to  $Y\uparrow$ , is calculated as the greater of the difference between the fastest and slowest of  $t_{PLHn}$  ( $n = 1, 2, 3, 4$ ) or  $t_{PLHn}$  ( $n = 9, 10, 11, 12$ ).
- B. Output skew,  $t_{sk(o)}$ , from  $CLK\uparrow$  to  $Q\uparrow$ , is calculated as the greater of the difference between the fastest and slowest of  $t_{PLHn}$  ( $n = 5, 6, 7, 8$ ).
- C. Output skew,  $t_{sk(o)}$ , from  $CLK\uparrow$  to  $Y\uparrow$  and  $Q\uparrow$ , is calculated as the greater of the difference between the fastest and slowest of  $t_{PLHn}$  ( $n = 1, 2, \dots, 8$ ).

**Figure 2. Skew Waveforms and Calculations**

**PACKAGING INFORMATION**

Orderable Device	Status <sup>(1)</sup>	Package Type	Package Drawing	Pins	Package Qty	Eco Plan <sup>(2)</sup>	Lead/Ball Finish	MSL Peak Temp <sup>(3)</sup>
CDC339DB	ACTIVE	SSOP	DB	20	70	Green (RoHS & no Sb/Br)	CU NIPDAU	Level-1-260C-UNLIM
CDC339DBG4	ACTIVE	SSOP	DB	20	70	Green (RoHS & no Sb/Br)	CU NIPDAU	Level-1-260C-UNLIM
CDC339DBG4	ACTIVE	SSOP	DB	20	70	Green (RoHS & no Sb/Br)	CU NIPDAU	Level-1-260C-UNLIM
CDC339DBLE	OBSOLETE	SSOP	DB	20		TBD	Call TI	Call TI
CDC339DBLE	OBSOLETE	SSOP	DB	20		TBD	Call TI	Call TI
CDC339DBR	ACTIVE	SSOP	DB	20	2000	Green (RoHS & no Sb/Br)	CU NIPDAU	Level-1-260C-UNLIM
CDC339DBR	ACTIVE	SSOP	DB	20	2000	Green (RoHS & no Sb/Br)	CU NIPDAU	Level-1-260C-UNLIM
CDC339DBRG4	ACTIVE	SSOP	DB	20	2000	Green (RoHS & no Sb/Br)	CU NIPDAU	Level-1-260C-UNLIM
CDC339DBRG4	ACTIVE	SSOP	DB	20	2000	Green (RoHS & no Sb/Br)	CU NIPDAU	Level-1-260C-UNLIM
CDC339DW	ACTIVE	SOIC	DW	20	25	Green (RoHS & no Sb/Br)	CU NIPDAU	Level-1-260C-UNLIM
CDC339DW	ACTIVE	SOIC	DW	20	25	Green (RoHS & no Sb/Br)	CU NIPDAU	Level-1-260C-UNLIM
CDC339DWG4	ACTIVE	SOIC	DW	20	25	Green (RoHS & no Sb/Br)	CU NIPDAU	Level-1-260C-UNLIM
CDC339DWG4	ACTIVE	SOIC	DW	20	25	Green (RoHS & no Sb/Br)	CU NIPDAU	Level-1-260C-UNLIM
CDC339DWR	ACTIVE	SOIC	DW	20	2000	Green (RoHS & no Sb/Br)	CU NIPDAU	Level-1-260C-UNLIM
CDC339DWR	ACTIVE	SOIC	DW	20	2000	Green (RoHS & no Sb/Br)	CU NIPDAU	Level-1-260C-UNLIM
CDC339DWRG4	ACTIVE	SOIC	DW	20	2000	Green (RoHS & no Sb/Br)	CU NIPDAU	Level-1-260C-UNLIM
CDC339DWRG4	ACTIVE	SOIC	DW	20	2000	Green (RoHS & no Sb/Br)	CU NIPDAU	Level-1-260C-UNLIM

<sup>(1)</sup> The marketing status values are defined as follows:

**ACTIVE:** Product device recommended for new designs.

**LIFEBUY:** TI has announced that the device will be discontinued, and a lifetime-buy period is in effect.

**NRND:** Not recommended for new designs. Device is in production to support existing customers, but TI does not recommend using this part in a new design.

**PREVIEW:** Device has been announced but is not in production. Samples may or may not be available.

**OBSOLETE:** TI has discontinued the production of the device.

<sup>(2)</sup> Eco Plan - The planned eco-friendly classification: Pb-Free (RoHS), Pb-Free (RoHS Exempt), or Green (RoHS & no Sb/Br) - please check <http://www.ti.com/productcontent> for the latest availability information and additional product content details.

**TBD:** The Pb-Free/Green conversion plan has not been defined.

**Pb-Free (RoHS):** TI's terms "Lead-Free" or "Pb-Free" mean semiconductor products that are compatible with the current RoHS requirements for all 6 substances, including the requirement that lead not exceed 0.1% by weight in homogeneous materials. Where designed to be soldered at high temperatures, TI Pb-Free products are suitable for use in specified lead-free processes.

**Pb-Free (RoHS Exempt):** This component has a RoHS exemption for either 1) lead-based flip-chip solder bumps used between the die and package, or 2) lead-based die adhesive used between the die and leadframe. The component is otherwise considered Pb-Free (RoHS compatible) as defined above.

**Green (RoHS & no Sb/Br):** TI defines "Green" to mean Pb-Free (RoHS compatible), and free of Bromine (Br) and Antimony (Sb) based flame retardants (Br or Sb do not exceed 0.1% by weight in homogeneous material)

<sup>(3)</sup> MSL, Peak Temp. -- The Moisture Sensitivity Level rating according to the JEDEC industry standard classifications, and peak solder temperature.

**Important Information and Disclaimer:**The information provided on this page represents TI's knowledge and belief as of the date that it is provided. TI bases its knowledge and belief on information provided by third parties, and makes no representation or warranty as to the accuracy of such information. Efforts are underway to better integrate information from third parties. TI has taken and continues to take reasonable steps to provide representative and accurate information but may not have conducted destructive testing or chemical analysis on incoming materials and chemicals. TI and TI suppliers consider certain information to be proprietary, and thus CAS numbers and other limited information may not be available for release.

In no event shall TI's liability arising out of such information exceed the total purchase price of the TI part(s) at issue in this document sold by TI to Customer on an annual basis.

**TAPE AND REEL BOX INFORMATION**

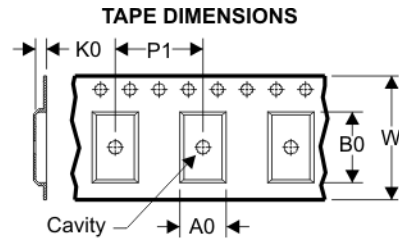
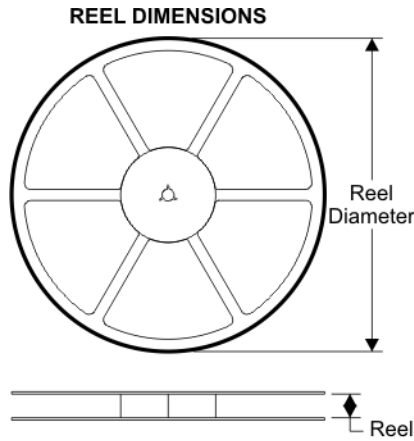

A0	Dimension designed to accommodate the component width
B0	Dimension designed to accommodate the component length
K0	Dimension designed to accommodate the component thickness
W	Overall width of the carrier tape
P1	Pitch between successive cavity centers

**QUADRANT ASSIGNMENTS FOR PIN 1 ORIENTATION IN TAPE**

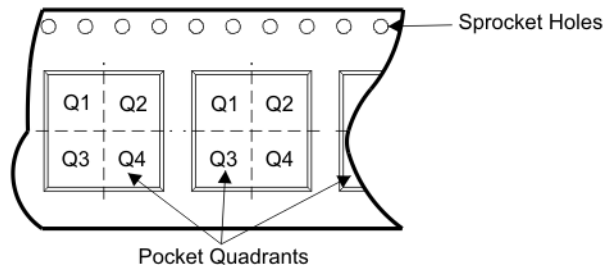

Device	Package	Pins	Site	Reel Diameter (mm)	Reel Width (mm)	A0 (mm)	B0 (mm)	K0 (mm)	P1 (mm)	W (mm)	Pin1 Quadrant
CDC339DBR	DB	20	SITE 41	330	16	8.2	7.5	2.5	12	16	Q1
CDC339DWR	DW	20	SITE 41	330	24	10.8	13.0	2.7	12	24	Q1

**TAPE AND REEL BOX DIMENSIONS**



Device	Package	Pins	Site	Length (mm)	Width (mm)	Height (mm)
CDC339DBR	DB	20	SITE 41	346.0	346.0	33.0
CDC339DWR	DW	20	SITE 41	346.0	346.0	41.0

DW (R-PDSO-G20)

PLASTIC SMALL-OUTLINE PACKAGE

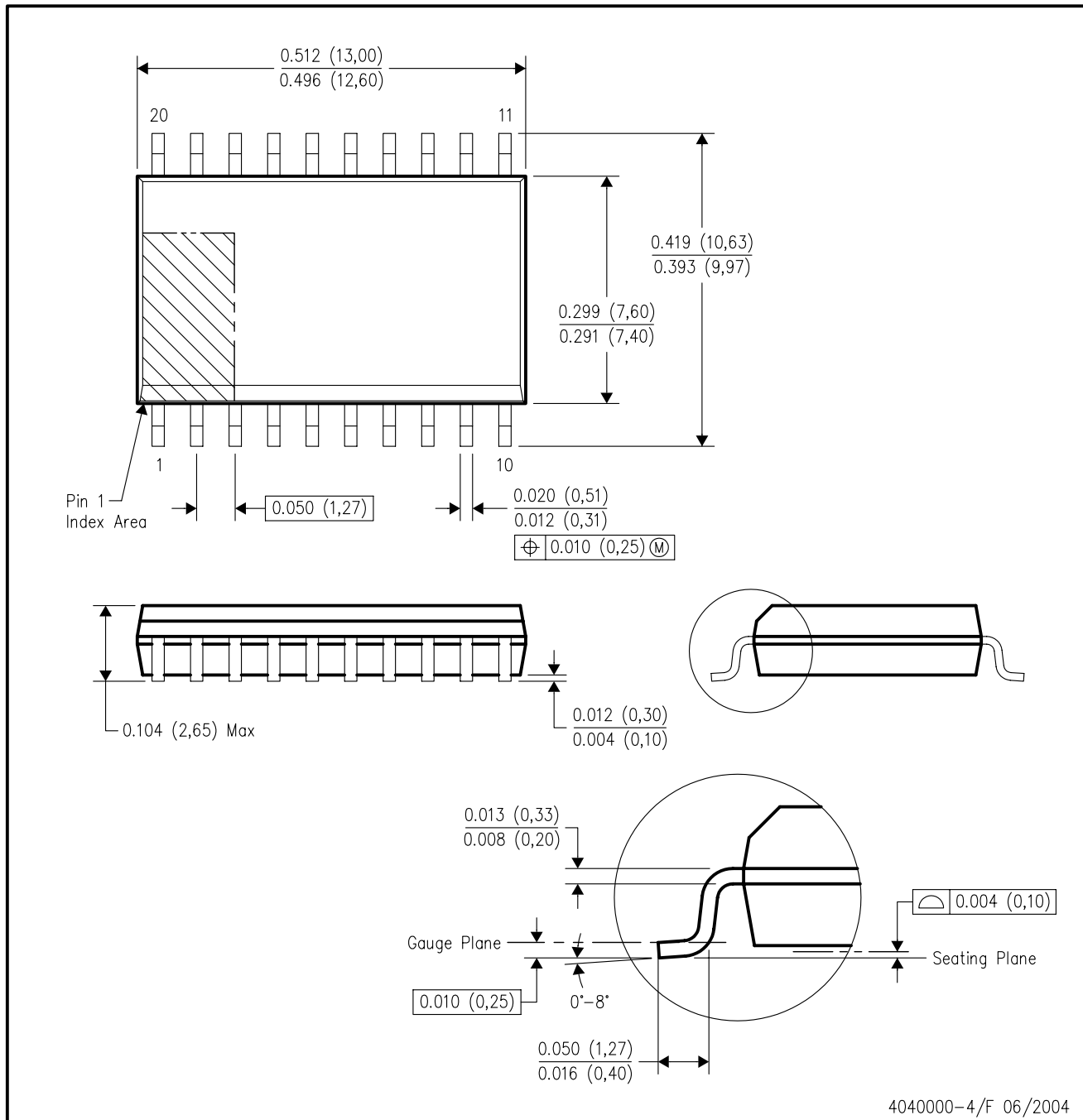

- NOTES:
- A. All linear dimensions are in inches (millimeters).
  - B. This drawing is subject to change without notice.
  - C. Body dimensions do not include mold flash or protrusion not to exceed 0.006 (0,15).
  - D. Falls within JEDEC MS-013 variation AC.

DB (R-PDSO-G\*\*)

PLASTIC SMALL-OUTLINE

28 PINS SHOWN



- NOTES: A. All linear dimensions are in millimeters.  
 B. This drawing is subject to change without notice.  
 C. Body dimensions do not include mold flash or protrusion not to exceed 0,15.  
 D. Falls within JEDEC MO-150

## IMPORTANT NOTICE

Texas Instruments Incorporated and its subsidiaries (TI) reserve the right to make corrections, modifications, enhancements, improvements, and other changes to its products and services at any time and to discontinue any product or service without notice. Customers should obtain the latest relevant information before placing orders and should verify that such information is current and complete. All products are sold subject to TI's terms and conditions of sale supplied at the time of order acknowledgment.

TI warrants performance of its hardware products to the specifications applicable at the time of sale in accordance with TI's standard warranty. Testing and other quality control techniques are used to the extent TI deems necessary to support this warranty. Except where mandated by government requirements, testing of all parameters of each product is not necessarily performed.

TI assumes no liability for applications assistance or customer product design. Customers are responsible for their products and applications using TI components. To minimize the risks associated with customer products and applications, customers should provide adequate design and operating safeguards.

TI does not warrant or represent that any license, either express or implied, is granted under any TI patent right, copyright, mask work right, or other TI intellectual property right relating to any combination, machine, or process in which TI products or services are used. Information published by TI regarding third-party products or services does not constitute a license from TI to use such products or services or a warranty or endorsement thereof. Use of such information may require a license from a third party under the patents or other intellectual property of the third party, or a license from TI under the patents or other intellectual property of TI.

Reproduction of TI information in TI data books or data sheets is permissible only if reproduction is without alteration and is accompanied by all associated warranties, conditions, limitations, and notices. Reproduction of this information with alteration is an unfair and deceptive business practice. TI is not responsible or liable for such altered documentation. Information of third parties may be subject to additional restrictions.

Resale of TI products or services with statements different from or beyond the parameters stated by TI for that product or service voids all express and any implied warranties for the associated TI product or service and is an unfair and deceptive business practice. TI is not responsible or liable for any such statements.

TI products are not authorized for use in safety-critical applications (such as life support) where a failure of the TI product would reasonably be expected to cause severe personal injury or death, unless officers of the parties have executed an agreement specifically governing such use. Buyers represent that they have all necessary expertise in the safety and regulatory ramifications of their applications, and acknowledge and agree that they are solely responsible for all legal, regulatory and safety-related requirements concerning their products and any use of TI products in such safety-critical applications, notwithstanding any applications-related information or support that may be provided by TI. Further, Buyers must fully indemnify TI and its representatives against any damages arising out of the use of TI products in such safety-critical applications.

TI products are neither designed nor intended for use in military/aerospace applications or environments unless the TI products are specifically designated by TI as military-grade or "enhanced plastic." Only products designated by TI as military-grade meet military specifications. Buyers acknowledge and agree that any such use of TI products which TI has not designated as military-grade is solely at the Buyer's risk, and that they are solely responsible for compliance with all legal and regulatory requirements in connection with such use.

TI products are neither designed nor intended for use in automotive applications or environments unless the specific TI products are designated by TI as compliant with ISO/TS 16949 requirements. Buyers acknowledge and agree that, if they use any non-designated products in automotive applications, TI will not be responsible for any failure to meet such requirements.

Following are URLs where you can obtain information on other Texas Instruments products and application solutions:

### Products

Amplifiers	<a href="http://amplifier.ti.com">amplifier.ti.com</a>
Data Converters	<a href="http://dataconverter.ti.com">dataconverter.ti.com</a>
DSP	<a href="http://dsp.ti.com">dsp.ti.com</a>
Clocks and Timers	<a href="http://www.ti.com/clocks">www.ti.com/clocks</a>
Interface	<a href="http://interface.ti.com">interface.ti.com</a>
Logic	<a href="http://logic.ti.com">logic.ti.com</a>
Power Mgmt	<a href="http://power.ti.com">power.ti.com</a>
Microcontrollers	<a href="http://microcontroller.ti.com">microcontroller.ti.com</a>
RFID	<a href="http://www.ti-rfid.com">www.ti-rfid.com</a>
RF/IF and ZigBee® Solutions	<a href="http://www.ti.com/lprf">www.ti.com/lprf</a>

### Applications

Audio	<a href="http://www.ti.com/audio">www.ti.com/audio</a>
Automotive	<a href="http://www.ti.com/automotive">www.ti.com/automotive</a>
Broadband	<a href="http://www.ti.com/broadband">www.ti.com/broadband</a>
Digital Control	<a href="http://www.ti.com/digitalcontrol">www.ti.com/digitalcontrol</a>
Medical	<a href="http://www.ti.com/medical">www.ti.com/medical</a>
Military	<a href="http://www.ti.com/military">www.ti.com/military</a>
Optical Networking	<a href="http://www.ti.com/opticalnetwork">www.ti.com/opticalnetwork</a>
Security	<a href="http://www.ti.com/security">www.ti.com/security</a>
Telephony	<a href="http://www.ti.com/telephony">www.ti.com/telephony</a>
Video & Imaging	<a href="http://www.ti.com/video">www.ti.com/video</a>
Wireless	<a href="http://www.ti.com/wireless">www.ti.com/wireless</a>

Mailing Address: Texas Instruments, Post Office Box 655303, Dallas, Texas 75265  
Copyright 2008, Texas Instruments Incorporated