

CDC950

133-MHz DIFFERENTIAL CLOCK SYNTHESIZER/DRIVER FOR PC MOTHERBOARDS/SERVERS

SCAS646B – FEBRUARY 2001 – REVISED OCTOBER 2003

- Generates Clocks for Next Generation Microprocessors
- Uses a 14.318-MHz Crystal Input to Generate Multiple Output Frequencies
- Includes Spread Spectrum Clocking (SSC), 0.6% Downspread for Reduced EMI With Theoretical EMI of 7 dB
- Power Management Control Terminals
- Low Output Skew and Jitter for Clock Distribution
- Operates From a Single 3.3-V Supply
- Generates the Following Clocks:
 - 8 Host (Diff Pairs, 100/133 MHz)
 - 1 CLK33 (3.3 V, 33.3 MHz)
 - 1 REFCLK (3.3 V, 14.318 MHz)
 - 2 3V48 (3.3 V, 180° Shifted Pairs, 48 MHz)
- Packaged in a 48-Pin TSSOP Package

description

The CDC950 is a differential clock synthesizer/driver that generates HCLK/HCLK, CLK33, 3V48, and REFCLK system clock signals to support a computer system with next generation processors and double data rate (DDR) memory subsystems.

All output frequencies are generated from a 14.318-MHz crystal input. A reference clock input can be provided at the XIN input instead of a crystal. Two phase-locked loops (PLLs) are used to generate the host frequencies and the 48-MHz clock frequencies. On-chip loop filters and internal feedback eliminate the need for external components.

The HCLK, CLK33 clock, and 48-MHz clock outputs provide low-skew/low-jitter clock signals for reliable clock operation. All outputs have 3-state capability, which can be selected through control inputs SEL100/133, 3V48/SelA, and 3V48/SelB.

The outputs are either differential host clock or 3.3-V single-ended CMOS buffers. With a logic high-level on the PWRDWN terminal, the device operates normally. When a logical low-level input is applied, the device powers down completely with the HOST clock at $2 \times I_{REF}$, HOSTB is undriven, CLK33, 3V48, and REFCLK outputs are in a low-level output state and 3V48B is in a high-level output state.

The host bus can operate at 100 MHz or 133 MHz. Output frequency selection is done with the corresponding setting for SEL100/133 control input. The CLK33 (PCI) frequency is fixed to 33 MHz.

Since the CDC950 is based on PLL circuitry, it requires a stabilization time to achieve phase-lock of the PLL. This stabilization time is required following power up, as well as following changes to the SEL inputs. With the use of an external reference clock, this signal must be fixed-frequency and fixed-phase prior to stabilization time starts. The CDC950 is characterized for operation from 0°C to 85°C.

DGG PACKAGE
(TOP VIEW)

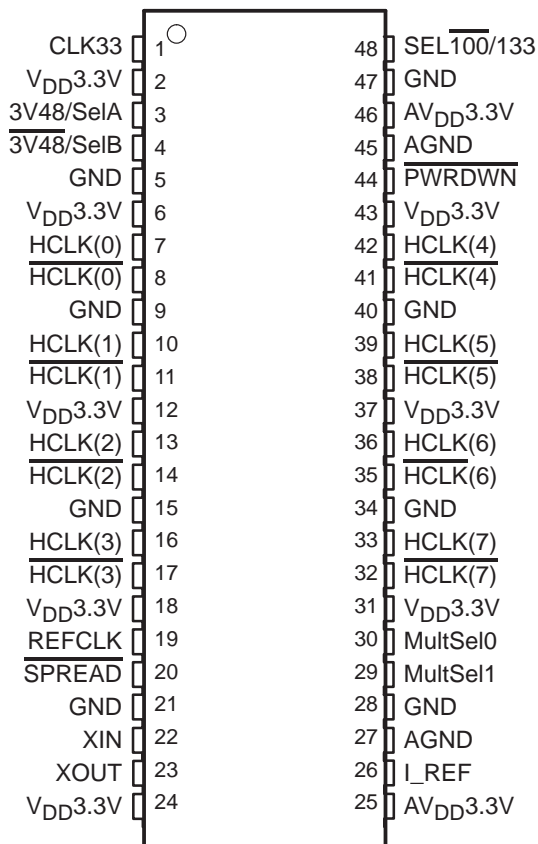

Please be aware that an important notice concerning availability, standard warranty, and use in critical applications of Texas Instruments semiconductor products and disclaimers thereto appears at the end of this data sheet.

PRODUCTION DATA information is current as of publication date. Products conform to specifications per the terms of Texas Instruments standard warranty. Production processing does not necessarily include testing of all parameters.



POST OFFICE BOX 655303 • DALLAS, TEXAS 75265

Copyright © 2001 – 2003, Texas Instruments Incorporated

CDC950

133-MHz DIFFERENTIAL CLOCK SYNTHESIZER/DRIVER FOR PC MOTHERBOARDS/SERVERS

SCAS646B – FEBRUARY 2001 – REVISED OCTOBER 2003

functional block diagram

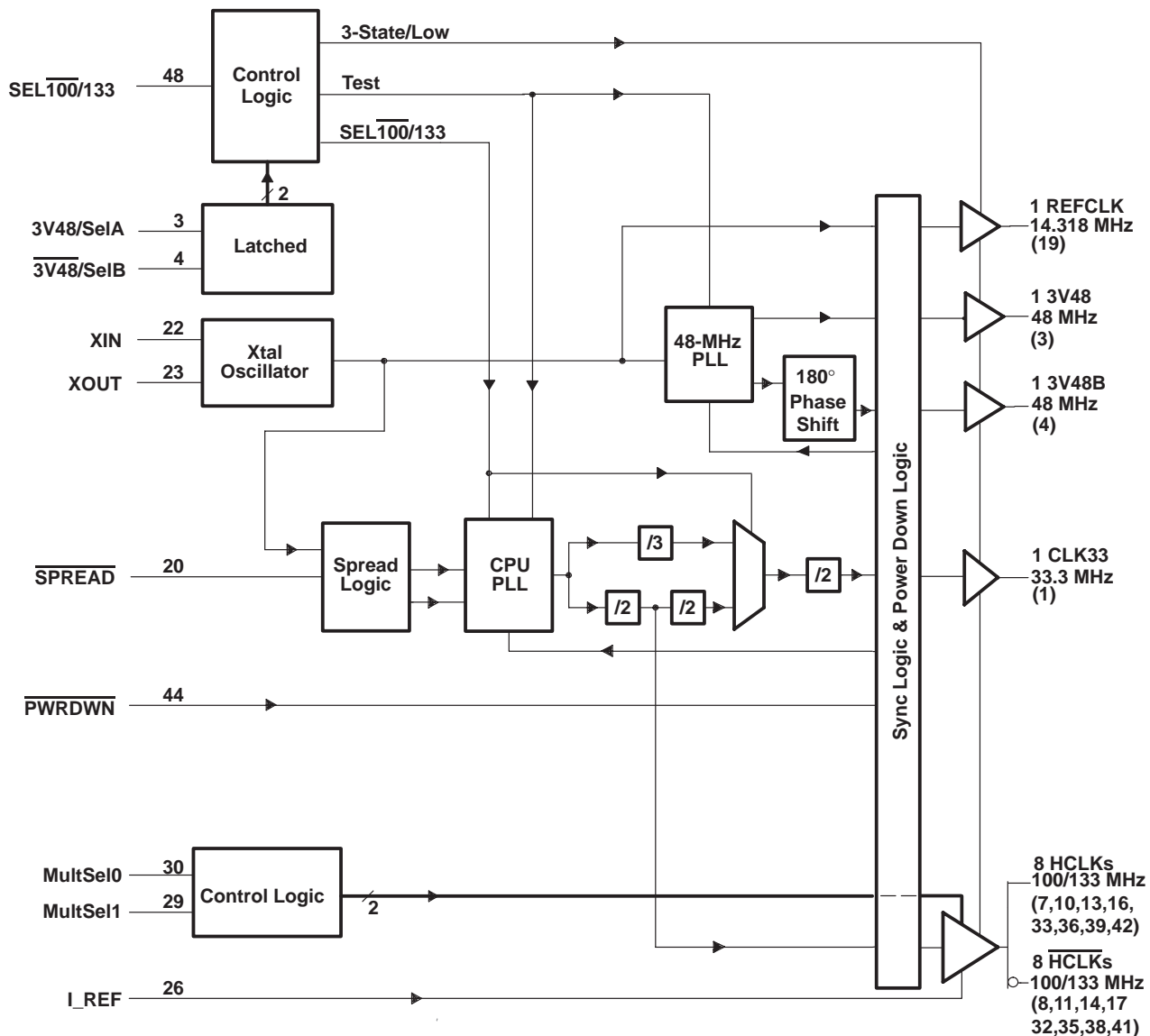

CDC950

133-MHz DIFFERENTIAL CLOCK SYNTHESIZER/DRIVER FOR PC MOTHERBOARDS/SERVERS

SCAS646B – FEBRUARY 2001 – REVISED OCTOBER 2003

Terminal Functions

| TERMINAL NAME | NO. | I/O | DESCRIPTION |
|----------------------------|-------------------------------------|-----|---|
| 3V48/SelA, 3V48/SelB | 3, 4 | I/O | 48-MHz 180° shifted pair clocks for USB use Logic select pins. Selects the mode of operation, see Table 1 for details. |
| AGND | 27, 45 | P | Analog ground |
| AV _{DD} 3.3V | 25, 46 | P | Power. Analog power supply |
| CLK33 | 1 | O | 33-MHz reference clock for PCI use, host clock divided by 3 or by 4 |
| GND | 5, 9, 15, 21, 28, 34, 40, 47 | P | Ground |
| HCLK | 7, 10, 13, 16, 33, 36, 39, 42 | O | CPU and host clock outputs [7:0]. These eight differential CPU clock pairs run at 100/133 MHz. The V _{OH} swing amplitude is configured by MultSel0, MultSel1 pins. See Table 5 and Intel's CK00 document for details. |
| $\overline{\text{HCLK}}$ | 8, 11, 14, 17, 32, 35, 38, 41 | O | CPU and host clock outputs [7:0]. These eight differential CPU clock pairs run at 100/133 MHz. The V _{OH} swing amplitude is configured by MultSel0, MultSel1 pins. See Table 5 and Intel's CK00 document for details. |
| I_REF | 26 | I | Current reference. This pin establishes the reference current for host clock parts. See Table 5 and Intel's CK00 document for details. |
| MultSel0 | 30 | I | See Table 5 and Intel's CK00 document for details. |
| MultSel1 | 29 | I | See Table 5 and Intel's CK00 document for details. |
| $\overline{\text{PWRDWN}}$ | 44 | I | Power-down input. 3.3-V LVTTTL compatible, asynchronous input that requests the device to enter the power-down mode. See Table 2 for details. |
| REFCLK | 19 | O | 14.138-MHz reference clock output: 3.3 V copy of the 14.318-MHz reference clock. |
| SEL100/133 | 48 | I | Active low LVTTTL level logic select. SEL100/133 is used for enabling 100/133 MHz. Low = 100 MHz, high = 133 MHz |
| $\overline{\text{SPREAD}}$ | 20 | U | Spread spectrum enable. 3.3-V LVTTTL compatible, input that enables the spread spectrum mode when held low. See Table 4 for details. |
| V _{DD} 3.3V | 2, 6, 12, 18, 24, 31, 37, 43 | P | Power. Power supply |
| XIN | 22 | I | Crystal connection or an external reference frequency input. Connect to either a 14.138-MHz crystal or an external reference signal. |
| XOUT | 23 | O | Crystal connection. An output connection for an external 14.318-MHz crystal. If using an external reference, this pin must be left unconnected. |

Function Tables

Table 1. Select Functions

| INPUTS | | | OUTPUTS | | | | FUNCTION |
|------------|------|------|--------------------------------|----------|-------------------------|------------|--------------------------------|
| SEL100/133 | SelA | SelB | HCLK, $\overline{\text{HCLK}}$ | CLK33 | 3V48, $\overline{3V48}$ | REFCLK | |
| 0 | 0 | 0 | 100 MHz | 33 MHz | 48 MHz | 14.318 MHz | Active 100 MHz |
| 0 | 0 | 1 | 100 MHz | 33 MHz | L, H | 14.318 MHz | 100 MHz mode; PLL48 powerdown |
| 0 | 1 | 0 | 105 MHz | 35 MHz | 48 MHz | 14.318 MHz | 100 MHz mode 5% overclocking |
| 0 | 1 | 1 | Hi-Z | Hi-Z | Hi-Z | Hi-Z | All 3-state outputs |
| 1 | 0 | 0 | 133 MHz | 33 MHz | 48 MHz | 14.318 MHz | Active 133 MHz |
| 1 | 0 | 1 | 127 MHz | 31.7 MHz | 48 MHz | 14.318 MHz | 133 MHz mode -5% underclocking |
| 1 | 1 | 0 | 133 MHz | 33 MHz | 48 MHz | 14.318 MHz | Test mode |
| 1 | 1 | 1 | TCLK/2 | TCLK/8 | TCLK/2 | TCLK | Test mode (PLL bypass) |

Table 2. Enable Functions

| INPUT | OUTPUTS | | | | | |
|----------------------------|---------------------------|--------------------------|-------|------|-------------------|--------|
| $\overline{\text{PWRDWN}}$ | HCLK | $\overline{\text{HCLK}}$ | CLK33 | 3V48 | $\overline{3V48}$ | REFCLK |
| 0 | $2 \times I_{\text{REF}}$ | Hi-Z | L | L | H | L |
| 1 | On | On | On | On | On | On |

Table 3. Output Buffer Specifications

| BUFFER NAME | V _{DD} RANGE (V) | IMPEDANCE (Ω) | BUFFER TYPE |
|--------------------------------|---------------------------|------------------------|-------------|
| 3V48, REFCLK | 3.135 – 3.465 | 20–60 | TYPE 3 |
| CLK33 | 3.135 – 3.465 | 12–55 | TYPE 5 |
| HCLK/ $\overline{\text{HCLK}}$ | 3.135 – 3.465 | | TYPE X1 |

Table 4. Spread Spectrum Functions

| INPUT | OUTPUTS |
|--------|--|
| SPREAD | |
| 0 | Spread spectrum clocking active, -0.6% at HCLK/ $\overline{\text{HCLK}}$, CLK33 |
| 1 | Spread spectrum clocking inactive |

Function Tables (Continued)

Table 5. Host/ $\overline{\text{HOST}}$ Output Buffer Specifications

| INPUT | | BOARD TARGET TRACE/TERM Z | REFERENCE R, $I_{REF} = V_{DD}/(3 R_r)$ | OUTPUT CURRENT I_{OH} | V_{OH} at Z |
|----------|----------|-------------------------------|--|--------------------------------------|---|
| MultSel0 | MultSel1 | | | | |
| 0 | 0 | 60 Ω | $R_r = 475\ 1\%$, $I_{REF} = 2.32\ \text{mA}$ | $5 \times I_{REF}$ | 0.71 V at 60 Ω |
| 0 | 0 | 50 Ω | $R_r = 475\ 1\%$, $I_{REF} = 2.32\ \text{mA}$ | $5 \times I_{REF}$ | 0.59 V at 50 Ω |
| 0 | 1 | 60 Ω | $R_r = 475\ 1\%$, $I_{REF} = 2.32\ \text{mA}$ | $6 \times I_{REF}$ | 0.85 V at 60 Ω |
| 0 | 1 | 50 Ω | $R_r = 475\ 1\%$, $I_{REF} = 2.32\ \text{mA}$ | $6 \times I_{REF}$ | 0.71 V at 50 Ω |
| 1 | 0 | 60 Ω | $R_r = 475\ 1\%$, $I_{REF} = 2.32\ \text{mA}$ | $4 \times I_{REF}$ | 0.56 V at 60 Ω |
| 1 | 0 | 50 Ω | $R_r = 475\ 1\%$, $I_{REF} = 2.32\ \text{mA}$ | $4 \times I_{REF}$ | 0.47 V at 50 Ω |
| 1 | 1 | 60 Ω | $R_r = 475\ 1\%$, $I_{REF} = 2.32\ \text{mA}$ | $7 \times I_{REF}$ | 0.99 V at 60 Ω |
| 1 | 1 | 50 Ω | $R_r = 475\ 1\%$, $I_{REF} = 2.32\ \text{mA}$ | $7 \times I_{REF}$ | 0.82 V at 50 Ω |
| 0 | 0 | 30 (dc equivalent) | $R_r = 221\ 1\%$, $I_{REF} = 5\ \text{mA}$ | $5 \times I_{REF}$ | 0.75 V at 30 Ω |
| 0 | 0 | 25 (dc equivalent) | $R_r = 221\ 1\%$, $I_{REF} = 5\ \text{mA}$ | $5 \times I_{REF}$ | 0.62 V at 25 Ω |
| 0 | 1 | 30 (dc equivalent) | $R_r = 221\ 1\%$, $I_{REF} = 5\ \text{mA}$ | $6 \times I_{REF}$ | 0.90 V at 30 Ω |
| 0 | 1 | 25 (dc equivalent) | $R_r = 221\ 1\%$, $I_{REF} = 5\ \text{mA}$ | $6 \times I_{REF}$ | 0.75 V at 25 Ω |
| 1 | 0 | 30 (dc equivalent) | $R_r = 221\ 1\%$, $I_{REF} = 5\ \text{mA}$ | $4 \times I_{REF}$ | 0.60 V at 30 Ω |
| 1 | 0 | 25 (dc equivalent) | $R_r = 221\ 1\%$, $I_{REF} = 5\ \text{mA}$ | $4 \times I_{REF}$ | 0.5 V at 25 Ω |
| 1 | 1 | 30 (dc equivalent) | $R_r = 221\ 1\%$, $I_{REF} = 5\ \text{mA}$ | $7 \times I_{REF}$ | 1.05 V at 30 Ω |
| 1 | 1 | 25 (dc equivalent) | $R_r = 221\ 1\%$, $I_{REF} = 5\ \text{mA}$ | $7 \times I_{REF}$ | 0.84 V at 25 Ω |

NOTE: The entries in **boldface** are the primary system configurations of interest. The outputs should be optimized for these configurations.

absolute maximum ratings over operating free-air temperature (unless otherwise noted)†

| | |
|---|------------------------------------|
| Supply voltage range, V_{DD} | -0.5 V to 4.3 V |
| Input voltage range, V_I (see Note 1) | -0.5 V to $V_{DD} + 0.5\ \text{V}$ |
| Voltage range applied to any output in the high-impedance or power-off state, V_O (see Note 1) | -0.5 V to $V_{DD} + 0.5\ \text{V}$ |
| Current into any output in the low state, I_O | $2 \times$ rated I_{OL} |
| Input clamp current, I_{IK} : ($V_I < 0$) | -50 mA |
| ($V_I > V_{DD}$) | 50 mA |
| Output clamp current, I_{OK} : ($V_O < 0$) | -50 mA |
| ($V_O > V_{DD}$) | 50 mA |
| Package thermal impedance, θ_{JA} (see Note 2) | 89°C/W |
| Maximum power dissipation at $T_A = 55^\circ\text{C}$ (in still air) (see Note 3) | 1070 mW |
| Operating free-air temperature range, T_A | -0°C to 85°C |
| Storage temperature range, T_{stg} | -65°C to 150°C |
| Lead temperature 1,6 mm (1/16 inch) from case for 10 seconds | 260°C |

† Stresses beyond those listed under “absolute maximum ratings” may cause permanent damage to the device. These are stress ratings only, and functional operation of the device at these or any other conditions beyond those indicated under “recommended operating conditions” is not implied. Exposure to absolute-maximum-rated conditions for extended periods may affect device reliability.

- NOTES:
- The input and output negative-voltage ratings may be exceeded if the input and output clamp-current ratings are observed.
 - The package thermal impedance is calculated in accordance with EIA/JEDEC Std JESD51, except for the through-hole packages, which use a trace length of zero.
 - The maximum package power dissipation is calculated using a junction temperature of 150°C and a board trace length of 750 mils. For more information, refer to the *Package Thermal Considerations* application note in the *ABT Advanced BiCMOS Technology Data Book*, literature number SCBD002.

CDC950

133-MHz DIFFERENTIAL CLOCK SYNTHESIZER/DRIVER FOR PC MOTHERBOARDS/SERVERS

SCAS646B – FEBRUARY 2001 – REVISED OCTOBER 2003

DISSIPATION RATING TABLE

| PACKAGE | $T_A \leq 25^\circ\text{C}$ POWER RATING | DERATING FACTOR† ABOVE $T_A = 25^\circ\text{C}$ | $T_A = 70^\circ\text{C}$ POWER RATING | $T_A = 85^\circ\text{C}$ POWER RATING |
|---------|---|--|--|--|
| DGG | 1400 mW | 11.2 mW/°C | 900 mW | 730 mW |

† This is the inverse of the traditional junction-to-case thermal resistance ($R_{\theta JA}$) and uses a board-mounted device at 89°C/W

recommended operating conditions (see Note 4)

| | | MIN | NOM‡ | MAX | UNIT | |
|---------------------------------------|-------------------------|-------|----------------|--------|------|------|
| Supply voltages, V_{DD} , AV_{DD} | | 3.135 | 3.3 | 3.465 | V | |
| High-level input voltage, V_{IH} | | 2 | | | | |
| Low-level input voltage, V_{IL} | | 0.8 | | | | |
| Input voltage, V_I | | -0.3 | $V_{DD} + 0.3$ | | | |
| High-level output current, I_{OH} | HCLK/HCLK | | | | mA | |
| | CLK33 | | | | | |
| | 3V48/SelA and 3V48/SelB | | | | | |
| | REFCLK | | | | | |
| Low-level output current, I_{OL} | HCLK/HCLK | 0 | | | | |
| | CLK33 | 12 | | | | |
| | 3V48/SelA and 3V48/SelB | 9 | | | | |
| | REFCLK | 9 | | | | |
| Reference frequency, $f_{(XIN)}^{\S}$ | Test mode | | 14 | | MHz | |
| Crystal, $f_{(XTAL)}^{\parallel}$ | Normal mode | | 13.8 | 14.318 | | 14.8 |
| Operating free-air temperature, T_A | | 0 | | 85 | | °C |

‡ All nominal values are measured at their respective nominal V_{DD} values.

§ Reference frequency is a test clock driven on the XIN input during the device test mode or normal mode. In test mode, XIN can be driven externally up to $f_{(XIN)} = 16$ MHz. If XIN is driven externally, XOUT is floating.

¶ This is a series fundamental crystal with $f_0 = 14.31818$ MHz

NOTE 4: Unused inputs must be held high or low to prevent them from floating.

CDC950

133-MHz DIFFERENTIAL CLOCK SYNTHESIZER/DRIVER FOR PC MOTHERBOARDS/SERVERS

SCAS646B – FEBRUARY 2001 – REVISED OCTOBER 2003

electrical characteristics over recommended operating free-air temperature range (unless otherwise noted)

| PARAMETER | | TEST CONDITIONS | | MIN | TYP† | MAX | UNIT |
|-----------------------|--------------------------------------|--|---|---------|------|------|------|
| V _{IK} | Input clamp voltage | V _{DD} = 3.135 V, I _I = -18 mA | | | | -1.2 | V |
| I _{IH} | High-level input current | All inputs except SelA, SelB | V _{DD} = 3.465 V, V _I = V _{DD} | | | 5 | μA |
| I _{IL} | Low-level input current | All inputs except SelA, SelB | V _{DD} = 3.465 V, V _I = GND | | | -5 | μA |
| I _{OZ} | High-impedance-state output current | All outputs including SelA, SelB | V _{DD} = 3.465 V 3V48/SelA, 3V48/SelB = H, SEL100/133 = L, V _O = V _{DD} or GND, PWRDWN = H | | | ±10 | μA |
| I _{DD(Z)} | High-impedance-state supply current‡ | | V _{DD} = 3.465 V 3V48/SelA, 3V48/SelB = H, SEL100/133 = L, PWRDWN = H | | 19 | 25 | mA |
| I _{DD(PD)} | | SelA, SelB = L R _(ref) = 475 Ω | VDD Supply | | 43 | 47 | mA |
| A _I DD(PD) | PWRDWN state supply current‡ | PWRDWN = L | AVDD Supply | | 3.4 | 4.2 | mA |
| I _{DD(D)} | Dynamic supply current‡ | V _{DD} = 3.465 V, R _{ref} = 475 Ω, I _O = 6 × I _{ref} | PWRDWN = H SSC = ON/OFF C _L = MAX | 100 MHz | 173 | 190 | mA |
| | | | | 133 MHz | 183 | 200 | |
| A _I DD | Analog power supply current | V _{DD} = 3.465 V | 100 MHz and SSC off | | 19 | 24 | mA |
| | | | 133 MHz and SSC off | | 26 | 33 | |
| | | | 100 MHz and SSC on | | 26 | 33 | |
| | | | 133 MHz and SSC on | | 35 | 45 | |
| C _I | Input capacitance§ | V _{DD} = 3.3 V, V _I = V _{DD} or GND | | 2 | | 5 | pF |
| C _(XTAL) | Crystal load capacitance¶ | Effective capacity between C _{IN} and C _{OUT} | | 13.5 | | 22.5 | |

† All typical values are measured at their respective nominal V_{DD} values.

‡ C_L = MAX = 5 pF, R_S = 33.2 Ω, R_p = 49.9 Ω at HCLK/HCLK (Type X1)

C_L = MAX = 20 pF, R_L = 500 Ω at 48 MHz, REF (Type 3)

C_L = MAX = 30 pF, R_L = 500 Ω at CLK33 (Type 5)

§ These parameters are assured by design and lab characterization, not 100% production tested.

¶ This is the corresponding capacitive load for the XTAL in this oscillator application (Pierce oscillator)

CDC950**133-MHz DIFFERENTIAL CLOCK SYNTHESIZER/DRIVER FOR PC MOTHERBOARDS/SERVERS**

SCAS646B – FEBRUARY 2001 – REVISED OCTOBER 2003

electrical characteristics over recommended operating free-air temperature range (unless otherwise noted) (continued)

HCLK/HCLK (Type X1)

| PARAMETER | | TEST CONDITIONS | | MIN | TYP† | MAX | UNIT |
|-----------|--------------------|------------------------------------|---|------|------|-----|----------|
| r_o | Output resistance | | | 3000 | | | Ω |
| V_O | Output voltage | | | 1.2 | | | V |
| I_O | Output current | $V_{DD} = 3.30\text{ V nom}$ | All combinations of Table 5, See Note 5 | -7% | | 7% | mA |
| | | $V_{DD} = 3.30\text{ V, } \pm 5\%$ | | -12% | | 12% | |
| C_O | Output capacitance | $V_{DD} = 3.30\text{ V nom}$ | $V_O = V_{DD}\text{ GND}$ | 3.5 | | | pF |

NOTE 5: $I_{(NOM)}$ is output current (I_{OH}) of table 5.**3V48, 3V48REFCLK (Type 3)**

| PARAMETER | | TEST CONDITIONS | | MIN | TYP† | MAX | UNIT |
|-----------|---------------------------|--|--------------------------------|----------------|------|-----|----------|
| V_{OH} | High-level output voltage | $V_{DD} = \text{min to max, } I_{OH} = -1\text{ mA}$ | | $V_{DD} - 0.1$ | | | V |
| | | $V_{DD} = 3.135\text{ V, } I_{OH} = -14\text{ mA}$ | | 2.4 | | | |
| V_{OL} | Low-level output voltage | $V_{DD} = \text{min to max, } I_{OL} = 1\text{ mA}$ | | 0.1 | | | V |
| | | $V_{DD} = 3.135\text{ V, } I_{OL} = 9\text{ mA}$ | | 0.18 0.4 | | | |
| I_{OH} | High-level output current | $V_{DD} = 3.135\text{ V, } V_O = 1\text{ V}$ | | -29 | | | mA |
| | | $V_{DD} = 3.3\text{ V, } V_O = 1.65\text{ V}$ | | -37 | | | |
| | | $V_{DD} = 3.465\text{ V, } V_O = 3.135\text{ V}$ | | -11 -23 | | | |
| I_{OL} | Low-level output current | $V_{DD} = 3.135\text{ V, } V_O = 1.95\text{ V}$ | | 29 | | | mA |
| | | $V_{DD} = 3.3\text{ V, } V_O = 1.65\text{ V}$ | | 39 | | | |
| | | $V_{DD} = 3.465\text{ V, } V_O = 0.4\text{ V}$ | | 16 27 | | | |
| C_O | Output capacitance | $V_{DD} = 3.3\text{ V, } V_O = V_{DD}\text{ or GND}$ | | 4.5 | | 7 | pF |
| Z_O | Output impedance | High state | $V_O = 0.5 V_{DD}, V_O/I_{OH}$ | 20 | 40 | 60 | Ω |
| | | Low state | $V_O = 0.5 V_{DD}, V_O/I_{OL}$ | 20 | 40 | 60 | |

† All typical values are measured at their respective nominal V_{DD} values.

CDC950

133-MHz DIFFERENTIAL CLOCK SYNTHESIZER/DRIVER FOR PC MOTHERBOARDS/SERVERS

SCAS646B – FEBRUARY 2001 – REVISED OCTOBER 2003

electrical characteristics over recommended operating free-air temperature range (unless otherwise noted) (continued)

CLK33 (Type 5)

| PARAMETER | | TEST CONDITIONS | | MIN | TYP† | MAX | UNIT |
|-----------------|---------------------------|--|--|-----------------------|------|-----|------|
| V _{OH} | High-level output voltage | V _{DD} = min to max, I _{OH} = -1 mA | | V _{DD} - 0.1 | | | V |
| | | V _{DD} = 3.135 V, I _{OH} = -18 mA | | 2.4 | | | |
| V _{OL} | Low-level output voltage | V _{DD} = min to max, I _{OL} = 1 mA | | | | 0.1 | V |
| | | V _{DD} = 3.135 V, I _{OL} = 12 mA | | | 0.15 | 0.4 | |
| I _{OH} | High-level output current | V _{DD} = 3.135 V, V _O = 1 V | | -33 | | | mA |
| | | V _{DD} = 3.3 V, V _O = 1.65 V | | -53 | | | |
| | | V _{DD} = 3.465 V, V _O = 3.135 V | | -16 | -33 | | |
| I _{OL} | Low-level output current | V _{DD} = 3.135 V, V _O = 1.95 V | | 30 | | | mA |
| | | V _{DD} = 3.3 V, V _O = 1.65 V | | 51 | | | |
| | | V _{DD} = 3.465 V, V _O = 0.4 V | | 21 | 38 | | |
| C _O | Output capacitance | V _{DD} = 3.3 V, V _O = V _{DD} or GND | | 4.5 | | 7.5 | pF |
| Z _O | Output impedance | High state | V _O = 0.5 V _{DD} , V _O /I _{OH} | 12 | 35 | 55 | Ω |
| | | Low state | V _O = 0.5 V _{DD} , V _O /I _{OL} | 12 | 35 | 55 | |

† All typical values are measured at their respective nominal V_{DD} values.

switching characteristics, V_{DD} = 3.135 V to 3.465 V, T_A = 0°C to 85°C

| PARAMETER | FROM (INPUT) | TO (OUTPUT) | TEST CONDITIONS | MIN | TYP | MAX | UNIT |
|----------------------|-------------------------------------|-------------------------|--|-----------------------|-----------------------|------|------|
| V _(over) | Overshoot† | | HCLK/HCLK 0.7-V amplitude | | V _{OH} + 200 | | mV |
| V _(under) | Undershoot† | | | | V _{OL} - 200 | | |
| V _(over) | Overshoot† | | Other clocks, C _L = worst case | GND - 0.7 | | | V |
| V _(under) | Undershoot† | | | V _{DD} + 0.7 | | | |
| t _{PZL} | Output enable time from low level | SEL ₁₀₀ /133 | All outputs SEL ₁₀₀ /133 ↑ R _{ref} = 475 Ω | | | 10 | ns |
| t _{PZH} | Output enable time to high level | SEL ₁₀₀ /133 | All outputs SEL ₁₀₀ /133 ↑ R _{ref} = 475 Ω | | | 10 | |
| t _{PHZ} | Output disable time from high level | SEL ₁₀₀ /133 | All outputs SEL ₁₀₀ /133 ↓ R _{ref} = 475 Ω | | | 10 | |
| t _{PLZ} | Output disable time from low level | SEL ₁₀₀ /133 | All outputs SEL ₁₀₀ /133 ↓ R _{ref} = 475 Ω | | | 10 | |
| t _s | Stabilization time‡ | V _{DD} | All outputs | After power up | | 0.1 | ms |
| | | PWRDWN | All outputs | From PWRDWN ↑ | | 0.25 | ms |

† These parameters are assured by design and lab characterization, not 100% production tested.

‡ Stabilization time is the time required for the integrated PLL circuit to obtain phase lock of its feedback signal to its reference signal. In order for phase lock to be obtained, a fixed-frequency, fixed-phase reference signal must be present at XIN. Until phase lock is obtained, the specifications for propagation delay and skew parameters given in the switching characteristics tables are not applicable. Stabilization time is defined as the time since V_{DD} achieves its nominal operating level (3.3 V) or PWRDWN transition from a low to a high level (2 V) until the output frequency is stable and operating within specification.

CDC950

133-MHz DIFFERENTIAL CLOCK SYNTHESIZER/DRIVER FOR PC MOTHERBOARDS/SERVERS

SCAS646B – FEBRUARY 2001 – REVISED OCTOBER 2003

switching characteristics, $V_{DD} = 3.135\text{ V to }3.465\text{ V}$, $T_A = 0^\circ\text{C to }85^\circ\text{C}$ (continued)

HCLK/HCLK (Type X1), $C_L = 2\text{ pF}$, $R_{ref} = 475\ \Omega$, $6 \times R_{ref}$

| PARAMETER | | TEST CONDITIONS | MIN | TYP | MAX | UNIT |
|---|-----------------|---|-----------------|------|-----------------|------|
| HCLK clock period [†] | | $f(\text{HCLK}) = 100\text{ MHz}$ | 10 | | 10.2 | ns |
| | | $f(\text{HCLK}) = 133\text{ MHz}$ | 7.5 | | 7.65 | |
| $T_{jit(cc)}$ Cycle-to-cycle jitter | | $f(\text{HCLK}) = 100\text{ or }133\text{ MHz}$ | SSC off | -80 | 80 | ps |
| | | | SSC on | -110 | 110 | |
| t_{dc} Duty cycle | | $f(\text{HCLK}) = 100\text{ or }133\text{ MHz}$, Crossing point | 45% | | 55% | |
| $t_{sk(o)}$ HCLK bus skew | | $f(\text{HCLK}) = 100\text{ or }133\text{ MHz}$, Crossing point | | 70 | | ps |
| t_r Rise time [†] | 0.7-V amplitude | $V_O = 0.14\text{ V to }0.56\text{ V}$ | | 175 | 700 | ps |
| t_f Fall time [†] | | | | 175 | 700 | |
| $V_{(cross)}$ Cross point voltages [†] | 0.7-V amplitude | $f(\text{HCLK}) = 100\text{ or }133\text{-MHz}$ HCLK and HCLK | 45% V_{OH} | | 55% V_{OH} | V |

[†] These parameters are assured by design and lab characterization, not 100% production tested.

[‡] The average over any 1- μs period of time is greater than the minimum specified period.

CLK33 (Type 5), $C_L = 30\text{ pF}$, $R_L = 500\ \Omega$

| PARAMETER | | TEST CONDITIONS | MIN | TYP | MAX | UNIT |
|-------------------------------------|--|---|------|-------|------|------|
| PCI clock period [†] | | $f(\text{HCLK}) = 100\text{ or }133\text{ MHz}$ | 30 | 30.06 | 30.6 | ns |
| $T_{jit(cc)}$ Cycle-to-cycle jitter | | $f(\text{HCLK}) = 100\text{ or }133\text{ MHz}$ | -150 | | 150 | ps |
| $t_{(dc)}$ Duty cycle | | $f(\text{CLK33}) = 33.3\text{ MHz}$ | 45% | | 55% | |
| t_r Rise time | | $V_O = 0.4\text{ V to }2.4\text{ V}$ | 0.5 | | 2 | ns |
| t_f Fall time | | $V_O = 0.4\text{ V to }2.4\text{ V}$ | 0.5 | | 2 | |

[†] The average over any 1- μs period of time is greater than the minimum specified period.

3V48 (Type 3), $C_L = 20\text{ pF}$, $R_L = 500\ \Omega$

| PARAMETER | | TEST CONDITIONS | MIN | TYP | MAX | UNIT |
|-------------------------------------|--|---|------|-------|-----|------|
| 3V48 clock period | | $f(\text{HCLK}) = 100\text{ or }133\text{ MHz}$ | | 20.83 | | ns |
| $T_{jit(cc)}$ Cycle-to-cycle jitter | | $f(\text{HCLK}) = 100\text{ or }133\text{ MHz}$ | -300 | | 300 | ps |
| t_{dc} Duty cycle | | $f(3V48) = 48\text{ MHz}$ | 45% | | 55% | |
| t_r Rise time | | $V_O = 0.4\text{ V to }2.4\text{ V}$ | 1 | | 4 | ns |
| t_f Fall time | | $V_O = 0.4\text{ V to }2.4\text{ V}$ | 1 | | 4 | |

REF (Type 3), $C_L = 20\text{ pF}$, $R_L = 500\ \Omega$

| PARAMETER | | TEST CONDITIONS | MIN | TYP | MAX | UNIT |
|-------------------------------------|--|---|------|-------|-----|------|
| REF clock period | | $f(\text{REF}) = 14.318\text{ MHz}$ | | 69.84 | | ns |
| $T_{jit(cc)}$ Cycle-to-cycle jitter | | $f(\text{HCLK}) = 100\text{ or }133\text{ MHz}$ | -0.5 | | 0.5 | |
| $t_{(dc)}$ Duty cycle | | $f(\text{REF}) = 14.318\text{ MHz}$ | 45% | | 55% | |
| t_r Rise time | | $V_O = 0.4\text{ V to }2.4\text{ V}$ | 1 | | 4 | ns |
| t_f Fall time | | $V_O = 0.4\text{ V to }2.4\text{ V}$ | 1 | | 4 | |



PARAMETER MEASUREMENT INFORMATION

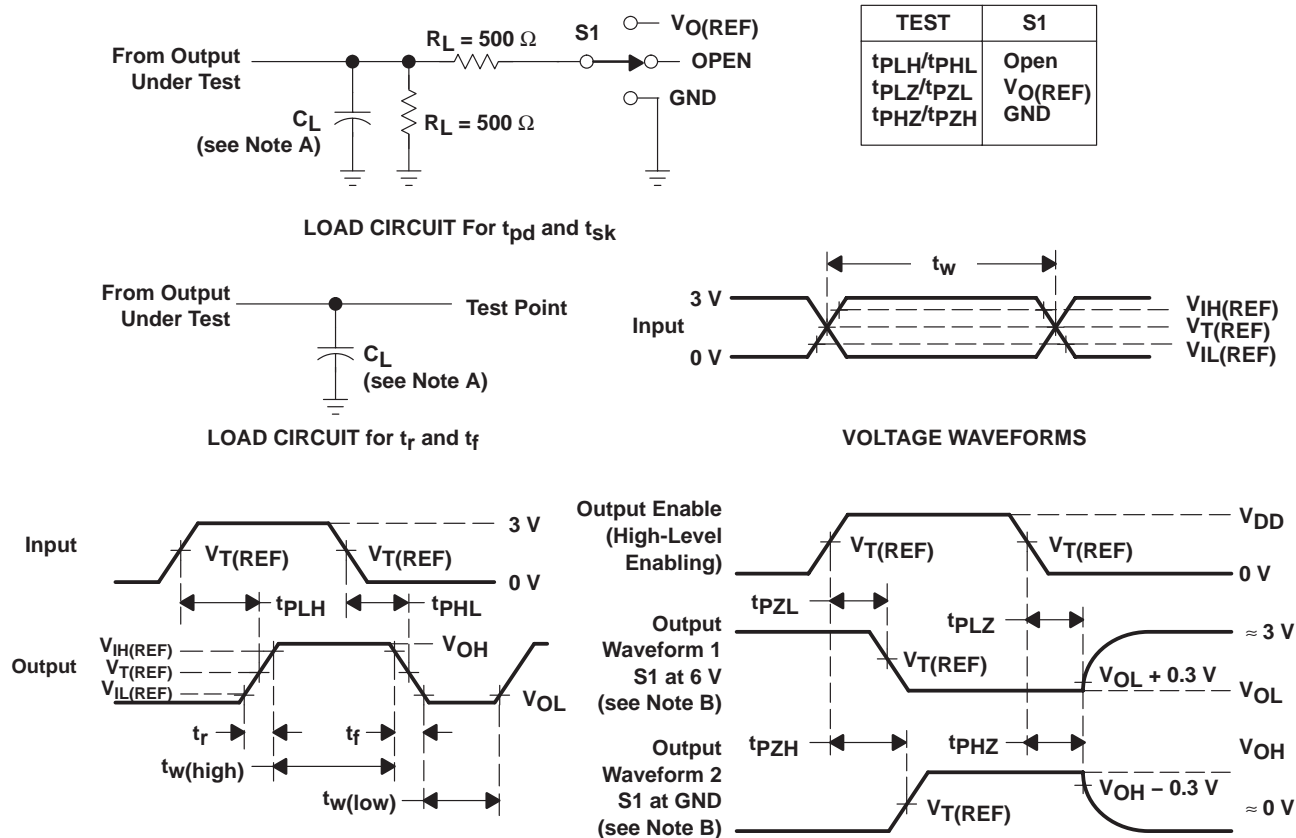

VOLTAGE WAVEFORMS

- NOTES: A. C_L includes probe and jig capacitance. C_L = 2 pF (HCLK, $\overline{\text{HCLK}}$), C_L = 20 pF (48 MHz, REF), C_L = 30 pF (CLK33).
 B. Waveform 1 is for an output with internal conditions such that the output is low except when disabled by the output control. Waveform 2 is for an output with internal conditions such that the output is high except when disabled by the output control.
 C. All input pulses are supplied by generators having the following characteristics: PRR ≤ 14.318 MHz, Z_O = 50 Ω, t_r ≤ 2.5 ns, t_f ≤ 2.5 ns.
 D. The outputs are measured one at a time with one transition per measurement.

| PARAMETER | | 3.3-V INTERFACE | UNIT |
|----------------------|-----------------------------------|-----------------|------|
| V _{IH(REF)} | High-level reference voltage | 2.4 | V |
| V _{IL(REF)} | Low-level reference voltage | 0.4 | |
| V _{T(REF)} | Input threshold reference voltage | 1.5 | |
| V _{O(REF)} | Off-state reference voltage | 6 | |

Figure 1. Load Circuit and Voltage Waveforms

CDC950
133-MHz DIFFERENTIAL CLOCK SYNTHESIZER/DRIVER FOR
PC MOTHERBOARDS/SERVERS

SCAS646B – FEBRUARY 2001 – REVISED OCTOBER 2003

APPLICATION INFORMATION

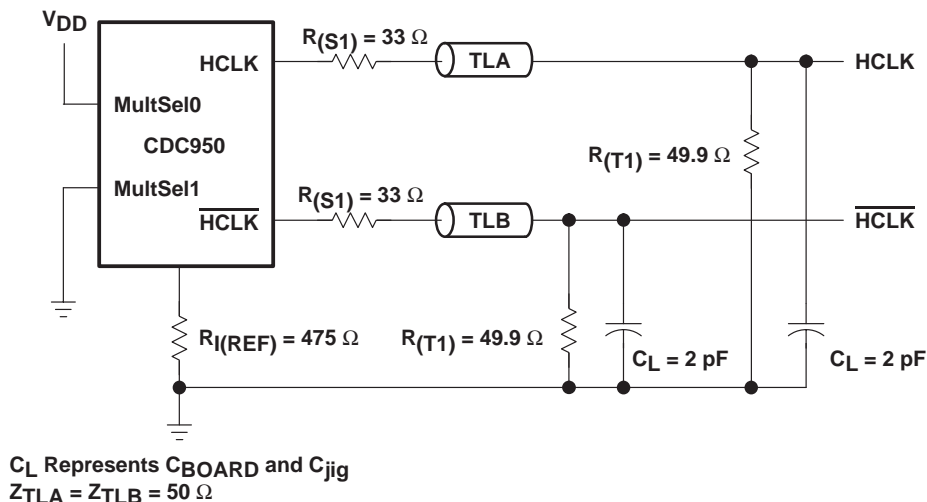

Figure 2. Load Circuit for HCLK Bus

spread spectrum clock (SSC) implementation for CDC950

Simultaneously switching at a fixed frequency generates a significant power peak at the selected frequency, which in turn causes EMI disturbance to the environment. The purpose of the internal frequency modulation of the CPU-PLL allows energy to be distributed to many different frequencies which reduces the power peak.

A typical characteristic for a single frequency spectrum and a frequency modulated spectrum is shown in Figure 3.

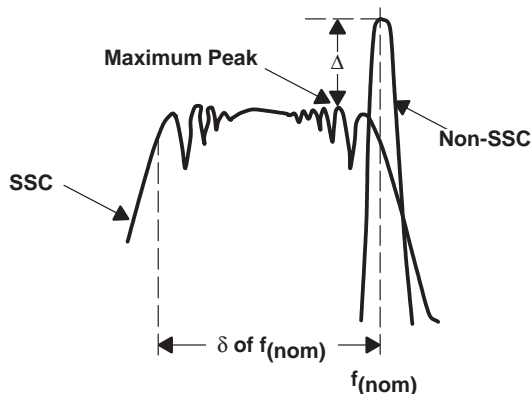

Figure 3. Frequency Power Spectrum With and Without the Use of SSC

The modulated spectrum has its distribution (left side) associated with the single-frequency spectrum which indicates a down-spread modulation.

The peak reduction depends on the modulation scheme and modulation profile. System performance and timing requirements are the limiting factors for actual design implementations. The implementation was driven to keep the average clock frequency close to its upper specification limit. The modulation amount was set to approximately -0.6%.

To allow a downstream PLL to follow the frequency modulated signal, the bandwidth of the modulation signal is limited in order to minimize SSC induced tracking skew jitter. The modulation frequency is approximately 31 kHz.

PACKAGING INFORMATION

| Orderable Device | Status ⁽¹⁾ | Package Type | Package Drawing | Pins | Package Qty | Eco Plan ⁽²⁾ | Lead/Ball Finish | MSL Peak Temp ⁽³⁾ |
|------------------|-----------------------|--------------|-----------------|------|-------------|-------------------------|------------------|------------------------------|
| CDC950DGG | ACTIVE | TSSOP | DGG | 48 | 40 | Green (RoHS & no Sb/Br) | CU NIPDAU | Level-2-260C-1 YEAR |
| CDC950DGGG4 | ACTIVE | TSSOP | DGG | 48 | 40 | Green (RoHS & no Sb/Br) | CU NIPDAU | Level-2-260C-1 YEAR |
| CDC950DGGR | ACTIVE | TSSOP | DGG | 48 | 2000 | Green (RoHS & no Sb/Br) | CU NIPDAU | Level-2-260C-1 YEAR |
| CDC950DGGRG4 | ACTIVE | TSSOP | DGG | 48 | 2000 | Green (RoHS & no Sb/Br) | CU NIPDAU | Level-2-260C-1 YEAR |

⁽¹⁾ The marketing status values are defined as follows:

ACTIVE: Product device recommended for new designs.

LIFEBUY: TI has announced that the device will be discontinued, and a lifetime-buy period is in effect.

NRND: Not recommended for new designs. Device is in production to support existing customers, but TI does not recommend using this part in a new design.

PREVIEW: Device has been announced but is not in production. Samples may or may not be available.

OBSOLETE: TI has discontinued the production of the device.

⁽²⁾ Eco Plan - The planned eco-friendly classification: Pb-Free (RoHS) or Green (RoHS & no Sb/Br) - please check <http://www.ti.com/productcontent> for the latest availability information and additional product content details.

TBD: The Pb-Free/Green conversion plan has not been defined.

Pb-Free (RoHS): TI's terms "Lead-Free" or "Pb-Free" mean semiconductor products that are compatible with the current RoHS requirements for all 6 substances, including the requirement that lead not exceed 0.1% by weight in homogeneous materials. Where designed to be soldered at high temperatures, TI Pb-Free products are suitable for use in specified lead-free processes.

Green (RoHS & no Sb/Br): TI defines "Green" to mean Pb-Free (RoHS compatible), and free of Bromine (Br) and Antimony (Sb) based flame retardants (Br or Sb do not exceed 0.1% by weight in homogeneous material)

⁽³⁾ MSL, Peak Temp. -- The Moisture Sensitivity Level rating according to the JEDEC industry standard classifications, and peak solder temperature.

Important Information and Disclaimer:The information provided on this page represents TI's knowledge and belief as of the date that it is provided. TI bases its knowledge and belief on information provided by third parties, and makes no representation or warranty as to the accuracy of such information. Efforts are underway to better integrate information from third parties. TI has taken and continues to take reasonable steps to provide representative and accurate information but may not have conducted destructive testing or chemical analysis on incoming materials and chemicals. TI and TI suppliers consider certain information to be proprietary, and thus CAS numbers and other limited information may not be available for release.

In no event shall TI's liability arising out of such information exceed the total purchase price of the TI part(s) at issue in this document sold by TI to Customer on an annual basis.

TAPE AND REEL INFORMATION



QUADRANT ASSIGNMENTS FOR PIN 1 ORIENTATION IN TAPE



*All dimensions are nominal

| Device | Package Type | Package Drawing | Pins | SPQ | Reel Diameter (mm) | Reel Width W1 (mm) | A0 (mm) | B0 (mm) | K0 (mm) | P1 (mm) | W (mm) | Pin1 Quadrant |
|------------|--------------|-----------------|------|------|--------------------|--------------------|---------|---------|---------|---------|--------|---------------|
| CDC950DGGR | TSSOP | DGG | 48 | 2000 | 330.0 | 24.4 | 8.6 | 15.6 | 1.8 | 12.0 | 24.0 | Q1 |

TAPE AND REEL BOX DIMENSIONS



*All dimensions are nominal

| Device | Package Type | Package Drawing | Pins | SPQ | Length (mm) | Width (mm) | Height (mm) |
|------------|--------------|-----------------|------|------|-------------|------------|-------------|
| CDC950DGGR | TSSOP | DGG | 48 | 2000 | 333.2 | 345.9 | 31.8 |

DGG (R-PDSO-G**)

PLASTIC SMALL-OUTLINE PACKAGE

48 PINS SHOWN



- NOTES: A. All linear dimensions are in millimeters.
 B. This drawing is subject to change without notice.
 C. Body dimensions do not include mold protrusion not to exceed 0,15.
 D. Falls within JEDEC MO-153

IMPORTANT NOTICE

Texas Instruments Incorporated and its subsidiaries (TI) reserve the right to make corrections, modifications, enhancements, improvements, and other changes to its products and services at any time and to discontinue any product or service without notice. Customers should obtain the latest relevant information before placing orders and should verify that such information is current and complete. All products are sold subject to TI's terms and conditions of sale supplied at the time of order acknowledgment.

TI warrants performance of its hardware products to the specifications applicable at the time of sale in accordance with TI's standard warranty. Testing and other quality control techniques are used to the extent TI deems necessary to support this warranty. Except where mandated by government requirements, testing of all parameters of each product is not necessarily performed.

TI assumes no liability for applications assistance or customer product design. Customers are responsible for their products and applications using TI components. To minimize the risks associated with customer products and applications, customers should provide adequate design and operating safeguards.

TI does not warrant or represent that any license, either express or implied, is granted under any TI patent right, copyright, mask work right, or other TI intellectual property right relating to any combination, machine, or process in which TI products or services are used. Information published by TI regarding third-party products or services does not constitute a license from TI to use such products or services or a warranty or endorsement thereof. Use of such information may require a license from a third party under the patents or other intellectual property of the third party, or a license from TI under the patents or other intellectual property of TI.

Reproduction of TI information in TI data books or data sheets is permissible only if reproduction is without alteration and is accompanied by all associated warranties, conditions, limitations, and notices. Reproduction of this information with alteration is an unfair and deceptive business practice. TI is not responsible or liable for such altered documentation. Information of third parties may be subject to additional restrictions.

Resale of TI products or services with statements different from or beyond the parameters stated by TI for that product or service voids all express and any implied warranties for the associated TI product or service and is an unfair and deceptive business practice. TI is not responsible or liable for any such statements.

TI products are not authorized for use in safety-critical applications (such as life support) where a failure of the TI product would reasonably be expected to cause severe personal injury or death, unless officers of the parties have executed an agreement specifically governing such use. Buyers represent that they have all necessary expertise in the safety and regulatory ramifications of their applications, and acknowledge and agree that they are solely responsible for all legal, regulatory and safety-related requirements concerning their products and any use of TI products in such safety-critical applications, notwithstanding any applications-related information or support that may be provided by TI. Further, Buyers must fully indemnify TI and its representatives against any damages arising out of the use of TI products in such safety-critical applications.

TI products are neither designed nor intended for use in military/aerospace applications or environments unless the TI products are specifically designated by TI as military-grade or "enhanced plastic." Only products designated by TI as military-grade meet military specifications. Buyers acknowledge and agree that any such use of TI products which TI has not designated as military-grade is solely at the Buyer's risk, and that they are solely responsible for compliance with all legal and regulatory requirements in connection with such use.

TI products are neither designed nor intended for use in automotive applications or environments unless the specific TI products are designated by TI as compliant with ISO/TS 16949 requirements. Buyers acknowledge and agree that, if they use any non-designated products in automotive applications, TI will not be responsible for any failure to meet such requirements.

Following are URLs where you can obtain information on other Texas Instruments products and application solutions:

| Products | | Applications | |
|-----------------------------|--|----------------------------|--|
| Amplifiers | amplifier.ti.com | Audio | www.ti.com/audio |
| Data Converters | dataconverter.ti.com | Automotive | www.ti.com/automotive |
| DLP® Products | www.dlp.com | Communications and Telecom | www.ti.com/communications |
| DSP | dsp.ti.com | Computers and Peripherals | www.ti.com/computers |
| Clocks and Timers | www.ti.com/clocks | Consumer Electronics | www.ti.com/consumer-apps |
| Interface | interface.ti.com | Energy | www.ti.com/energy |
| Logic | logic.ti.com | Industrial | www.ti.com/industrial |
| Power Mgmt | power.ti.com | Medical | www.ti.com/medical |
| Microcontrollers | microcontroller.ti.com | Security | www.ti.com/security |
| RFID | www.ti-rfid.com | Space, Avionics & Defense | www.ti.com/space-avionics-defense |
| RF/IF and ZigBee® Solutions | www.ti.com/lprf | Video and Imaging | www.ti.com/video |
| | | Wireless | www.ti.com/wireless-apps |