

**Features**

- $I_{off}$  supports partial-power-down mode operation
- Edge-rate control circuitry for significantly improved noise characteristics
- Typical output skew < 250 ps
- ESD > 2000V
- TSSOP (19.6-mil pitch) and SSOP (25-mil pitch) packages
- Industrial temperature range of  $-40^{\circ}\text{C}$  to  $+85^{\circ}\text{C}$
- $V_{CC} = 5\text{V} \pm 10\%$

*CY74FCT16823T Features:*

- 64 mA sink current, 32 mA source current
- Typical  $V_{OLP}$  (ground bounce) < 1.0V at  $V_{CC} = 5\text{V}$ ,  $T_A = 25^{\circ}\text{C}$

*CY74FCT162823T Features:*

- Balanced 24 mA output drivers
- Reduced system switching noise
- Typical  $V_{OLP}$  (ground bounce) < 0.6V at  $V_{CC} = 5\text{V}$ ,  $T_A = 25^{\circ}\text{C}$

**Functional Description**

The CY74FCT16823T and the CY74FCT162823T 18-bit bus interface registers are designed for use in high-speed, low-power systems needing wide registers and parity. 18-bit operation is achieved by connecting the control lines of the two 9-bit registers. Flow-through pinout and small shrink packaging aids in simplifying board layout.

This device is fully specified for partial-power-down applications using  $I_{off}$ . The  $I_{off}$  circuitry disables the outputs, preventing damaging current backflow through the device when it is powered down.

The CY74FCT16823T is ideally suited for driving high-capacitance loads and low-impedance backplanes.

The CY74FCT162823T has 24-mA balanced output drivers with current limiting resistors in the outputs. This reduces the need for external terminating resistors and provides for minimal undershoot and reduced ground bounce. The CY74FCT162823T is ideal for driving transmission lines.

**Logic Block Diagrams**

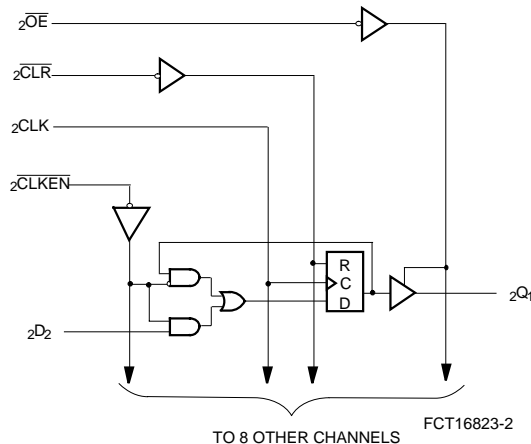
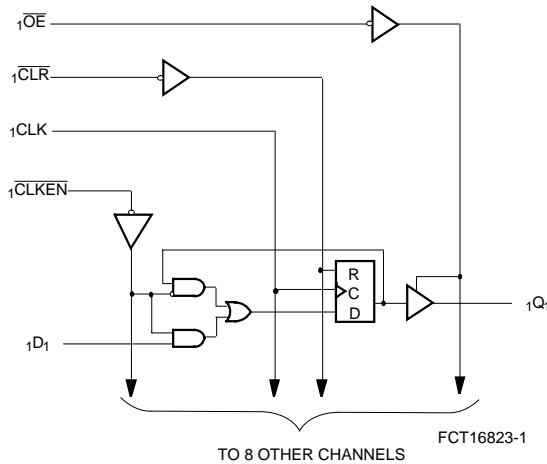

**Pin Configuration  
SSOP/TSSOP**

**Top View**

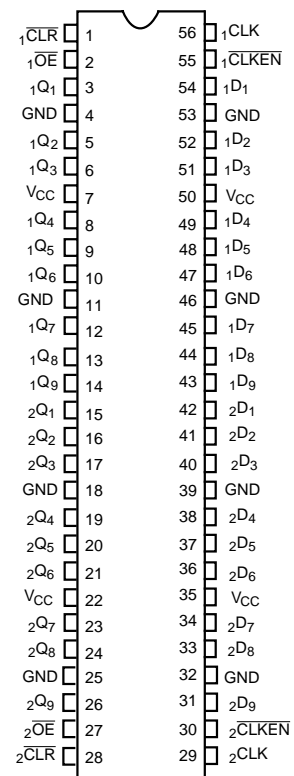

**Pin Description**

| Name  | Description                            |
|-------|--|
| D     | Data Inputs                            |
| CLK   | Clock Inputs                           |
| CLKEN | Clock Enable Inputs (Active LOW)       |
| CLR   | Asynchronous Clear Inputs (Active LOW) |
| OE    | Output Enable Inputs (Active LOW)      |
| Q     | Three-State Outputs                    |

**Function Table<sup>[1]</sup>**

| Inputs |     |       |     |   |                  | Outputs  |
|--------|-----|-------|-----|---|------------------|----------|
| OE     | CLR | CLKEN | CLK | D | Q                | Function |
| H      | X   | X     | X   | X | Z                | High Z   |
| L      | L   | X     | X   | X | L                | Clear    |
| L      | H   | H     | X   | X | Q <sup>[2]</sup> | Hold     |
| H      | H   | L     | ┐   | L | Z                | Load     |
| H      | H   | L     | ┐   | H | Z                |          |
| L      | H   | L     | ┐   | L | L                |          |
| L      | H   | L     | ┐   | H | H                |          |

**Maximum Ratings<sup>[3, 4]</sup>**

(Above which the useful life may be impaired. For user guidelines, not tested.)

Storage Temperature ..... -55°C to +125°C

Ambient Temperature with  
Power Applied ..... -55°C to +125°C

DC Input Voltage ..... -0.5V to +7.0V

DC Output Voltage ..... -0.5V to +7.0V

DC Output Current  
(Maximum Sink Current/Pin) ..... -60 to +120 mA

Power Dissipation ..... 1.0W

Static Discharge Voltage ..... >2001V  
(per MIL-STD-883, Method 3015)

**Operating Range**

| Range      | Ambient Temperature | V <sub>CC</sub> |
|------------|---------------------|-----------------|
| Industrial | -40°C to +85°C      | 5V ± 10%        |

**Notes:**

- H = HIGH Voltage Level.  
L = LOW Voltage Level.  
X = Don't Care.  
Z = HIGH Impedance.  
┐ = LOW-to-HIGH transition.
- Output level before indicated steady-state input conditions were established.
- Operation beyond the limits set forth may impair the useful life of the device. Unless otherwise noted, these limits are over the operating free-air temperature range.
- Unused inputs must always be connected to an appropriate logic voltage level, preferably either V<sub>CC</sub> or ground.

**Electrical Characteristics** Over the Operating Range

| Parameter        | Description   | Test Conditions  | Min. | Typ. <sup>[5]</sup> | Max. | Unit |
|------------------|---|--|------|---------------------|------|------|
| V <sub>IH</sub>  | Input HIGH Voltage                                      |  | 2.0  |                     |      | V    |
| V <sub>IL</sub>  | Input LOW Voltage                                       |  |      |                     | 0.8  | V    |
| V <sub>H</sub>   | Input Hysteresis <sup>[6]</sup>                         |  |      | 100                 |      | mV   |
| V <sub>IK</sub>  | Input Clamp Diode Voltage                               | V <sub>CC</sub> =Min., I <sub>IN</sub> =-18 mA             |      | -0.7                | -1.2 | V    |
| I <sub>IH</sub>  | Input HIGH Current                                      | V <sub>CC</sub> =Max., V <sub>I</sub> =V <sub>CC</sub>     |      |                     | ±1   | μA   |
| I <sub>IL</sub>  | Input LOW Current                                       | V <sub>CC</sub> =Max., V <sub>I</sub> =GND                 |      |                     | ±1   | μA   |
| I <sub>OZH</sub> | High Impedance Output Current (Three-State Output pins) | V <sub>CC</sub> =Max., V <sub>OUT</sub> =2.7V              |      |                     | ±1   | μA   |
| I <sub>OZL</sub> | High Impedance Output Current (Three-State Output pins) | V <sub>CC</sub> =Max., V <sub>OUT</sub> =0.5V              |      |                     | ±1   | μA   |
| I <sub>OS</sub>  | Short Circuit Current <sup>[7]</sup>                    | V <sub>CC</sub> =Max., V <sub>OUT</sub> =GND               | -80  | -140                | -200 | mA   |
| I <sub>O</sub>   | Output Drive Current <sup>[7]</sup>                     | V <sub>CC</sub> =Max., V <sub>OUT</sub> =2.5V              | -50  |                     | -180 | mA   |
| I <sub>OFF</sub> | Power-Off Disable                                       | V <sub>CC</sub> =0V, V <sub>OUT</sub> ≤4.5V <sup>[8]</sup> |      |                     | 1    | μA   |

**Output Drive Characteristics for CY74FCT16823T**

| Parameter       | Description         | Test Conditions                                | Min. | Typ. <sup>[5]</sup> | Max. | Unit |
|-----------------|---------------------|--|------|---------------------|------|------|
| V <sub>OH</sub> | Output HIGH Voltage | V <sub>CC</sub> =Min., I <sub>OH</sub> =-3 mA  | 2.5  | 3.5                 |      | V    |
|                 |                     | V <sub>CC</sub> =Min., I <sub>OH</sub> =-15 mA | 2.4  | 3.5                 |      |      |
|                 |                     | V <sub>CC</sub> =Min., I <sub>OH</sub> =-32 mA | 2.0  | 3.0                 |      |      |
| V <sub>OL</sub> | Output LOW Voltage  | V <sub>CC</sub> =Min., I <sub>OL</sub> =64 mA  |      | 0.2                 | 0.55 | V    |

**Output Drive Characteristics for CY74FCT162823T**

| Parameter        | Description                        | Test Conditions   | Min. | Typ. <sup>[5]</sup> | Max. | Unit |
|------------------|------------------------------------|---|------|---------------------|------|------|
| I <sub>ODL</sub> | Output LOW Voltage <sup>[7]</sup>  | V <sub>CC</sub> =5V, V <sub>IN</sub> =V <sub>IH</sub> or V <sub>IL</sub> , V <sub>OUT</sub> =1.5V | 60   | 115                 | 150  | mA   |
| I <sub>ODH</sub> | Output HIGH Voltage <sup>[7]</sup> | V <sub>CC</sub> =5V, V <sub>IN</sub> =V <sub>IH</sub> or V <sub>IL</sub> , V <sub>OUT</sub> =1.5V | -60  | -115                | -150 | mA   |
| V <sub>OH</sub>  | Output HIGH Voltage                | V <sub>CC</sub> =Min., I <sub>OH</sub> =-24 mA  | 2.4  | 3.3                 |      | V    |
| V <sub>OL</sub>  | Output LOW Voltage                 | V <sub>CC</sub> =Min., I <sub>OL</sub> =24 mA   |      | 0.3                 | 0.55 | V    |

**Capacitance<sup>[9]</sup>** (T<sub>A</sub> = +25°C, f = 1.0 MHz)

| Parameter        | Description        | Test Conditions       | Typ. <sup>[5]</sup> | Max. | Unit |
|------------------|--------------------|-----------------------|---------------------|------|------|
| C <sub>IN</sub>  | Input Capacitance  | V <sub>IN</sub> = 0V  | 4.5                 | 6.0  | pF   |
| C <sub>OUT</sub> | Output Capacitance | V <sub>OUT</sub> = 0V | 5.5                 | 8.0  | pF   |

**Notes:**

5. Typical values are at V<sub>CC</sub>= 5.0V, T<sub>A</sub>= +25°C ambient.
6. This input is specified but not tested.
7. Not more than one output should be shorted at a time. Duration of short should not exceed one second. The use of high-speed test apparatus and/or sample and hold techniques are preferable in order to minimize internal chip heating and more accurately reflect operational values. Otherwise prolonged shorting of a high output may raise the chip temperature well above normal and thereby cause invalid readings in other parametric tests. In any sequence of parameter tests, I<sub>OS</sub> tests should be performed last.
8. Tested at +25°C.
9. This parameter is specified but not tested.

**Power Supply Characteristics**

| Parameter       | Description                                      | Test Conditions <sup>[10]</sup>   |   | Min. | Typ. <sup>[5]</sup> | Max.                 | Unit               |
|-----------------|--|---|---|------|---------------------|----------------------|--------------------|
| $I_{CC}$        | Quiescent Power Supply Current                   | $V_{CC}=\text{Max.}$  | $V_{IN}\leq 0.2V$<br>$V_{IN}\geq V_{CC}-0.2V$ | —    | 5                   | 500                  | $\mu A$            |
| $\Delta I_{CC}$ | Quiescent Power Supply Current (TTL inputs HIGH) | $V_{CC}=\text{Max.}$  | $V_{IN}=3.4V^{[11]}$                          | —    | 0.5                 | 1.5                  | mA                 |
| $I_{CCD}$       | Dynamic Power Supply Current <sup>[12]</sup>     | $V_{CC}=\text{Max.}$ ,<br>One Input Toggling,<br>50% Duty Cycle,<br>Outputs Open,<br>$OE=\text{CLKEN}=\text{GND}$   | $V_{IN}=V_{CC}$ or<br>$V_{IN}=\text{GND}$     | —    | 75                  | 120                  | $\mu A/\text{MHz}$ |
| $I_C$           | Total Power Supply Current <sup>[13]</sup>       | $V_{CC}=\text{Max.}$ ,<br>$f_0=10\text{ MHz}$ ,<br>50% Duty Cycle,<br>Outputs Open,<br>One Bit Toggling,<br>$OE=\text{CLKEN}=\text{GND}$<br>at $f_1=5\text{ MHz}$         | $V_{IN}=V_{CC}$ or<br>$V_{IN}=\text{GND}$     | —    | 0.8                 | 1.7                  | mA                 |
|                 |  |   | $V_{IN}=3.4V$ or<br>$V_{IN}=\text{GND}$       | —    | 1.3                 | 3.2                  |                    |
|                 |  | $V_{CC}=\text{Max.}$ ,<br>at $f_1=2.5\text{ MHz}$ ,<br>50% Duty Cycle,<br>Outputs Open,<br>Eighteen Bits Toggling,<br>$OE=\text{CLKEN}=\text{GND}$<br>$f_0=10\text{ MHz}$ | $V_{IN}=V_{CC}$ or<br>$V_{IN}=\text{GND}$     | —    | 4.2                 | 7.1 <sup>[14]</sup>  |                    |
|                 |  |   | $V_{IN}=3.4V$ or<br>$V_{IN}=\text{GND}$       | —    | 9.2                 | 22.1 <sup>[14]</sup> |                    |

**Notes:**

10. For conditions shown as Max. or Min., use appropriate value specified under Electrical Characteristics for the applicable device type.
11. Per TTL driven input ( $V_{IN}=3.4V$ ); all other inputs at  $V_{CC}$  or GND.
12. This parameter is not directly testable, but is derived for use in Total Power Supply calculations.
13.  $I_C = I_{\text{QUIESCENT}} + I_{\text{INPUTS}} + I_{\text{DYNAMIC}}$   
 $I_C = I_{CC} + \Delta I_{CC} D_H N_T + I_{CCD} (f_0/2 + f_1 N_1)$   
 $I_{CC}$  = Quiescent Current with CMOS input levels  
 $\Delta I_{CC}$  = Power Supply Current for a TTL HIGH input ( $V_{IN}=3.4V$ )  
 $D_H$  = Duty Cycle for TTL inputs HIGH  
 $N_T$  = Number of TTL inputs at  $D_H$   
 $I_{CCD}$  = Dynamic Current caused by an input transition pair (HLH or LHL)  
 $f_0$  = Clock frequency for registered devices, otherwise zero  
 $f_1$  = Input signal frequency  
 $N_1$  = Number of inputs changing at  $f_1$   
 All currents are in milliamperes and all frequencies are in megahertz.
14. Values for these conditions are examples of the  $I_{CC}$  formula. These limits are specified but not tested.

**Switching Characteristics** Over the Operating Range<sup>[15]</sup>

| Parameter                            | Description   | Condition <sup>[16]</sup>                                      | CY74FCT16823AT<br>CY74FCT162823AT |      | Unit | Fig.No. <sup>[16]</sup> |
|--------------------------------------|---|--|-----------------------------------|------|------|-------------------------|
|                                      |   |  | Min.                              | Max. |      |                         |
| t <sub>PLH</sub><br>t <sub>PHL</sub> | Propagation Delay CLK to Q                                | C <sub>L</sub> =50 pF<br>R <sub>L</sub> =500Ω                  | 1.5                               | 10.0 | ns   | 1, 5                    |
|                                      |   | C <sub>L</sub> =300 pF <sup>[17]</sup><br>R <sub>L</sub> =500Ω | 1.5                               | 20.0 |      |                         |
| t <sub>PHL</sub>                     | Propagation Delay $\overline{\text{CLR}}$ to Q            | C <sub>L</sub> =50 pF<br>R <sub>L</sub> =500Ω                  | 1.5                               | 14.0 | ns   | 1, 5                    |
| t <sub>PZH</sub><br>t <sub>PZL</sub> | Output Enable Time $\overline{\text{OE}}$ to Q            | C <sub>L</sub> =50 pF<br>R <sub>L</sub> =500Ω                  | 1.5                               | 12.0 | ns   | 1, 7, 8                 |
|                                      |   | C <sub>L</sub> =300 pF <sup>[17]</sup><br>R <sub>L</sub> =500Ω | 1.5                               | 23.0 |      |                         |
| t <sub>PHZ</sub><br>t <sub>PLZ</sub> | Output Disable Time $\overline{\text{OE}}$ to Q           | C <sub>L</sub> =5 pF <sup>[17]</sup><br>R <sub>L</sub> =500Ω   | 1.5                               | 7.0  | ns   | 1, 7, 8                 |
|                                      |   | C <sub>L</sub> =50 pF<br>R <sub>L</sub> =500Ω                  | 1.5                               | 8.0  |      |                         |
| t <sub>SU</sub>                      | Set-Up Time HIGH or LOW, D to CLK                         | C <sub>L</sub> =50 pF<br>R <sub>L</sub> =500Ω                  | 3.0                               | —    | ns   | 4                       |
| t <sub>H</sub>                       | Hold Time HIGH or LOW, D to CLK                           |  | 1.5                               | —    | ns   | 4                       |
| t <sub>SU</sub>                      | Set-Up Time HIGH or LOW, $\overline{\text{CLKEN}}$ to CLK |  | 3.0                               | —    | ns   | 9                       |
| t <sub>H</sub>                       | Hold Time HIGH or LOW $\overline{\text{CLKEN}}$ to CLK    |  | 0.0                               | —    | ns   | 9                       |
| t <sub>W</sub>                       | CLK Pulse Width HIGH or LOW                               |  | 6.0                               | —    | ns   | 5                       |
| t <sub>W</sub>                       | $\overline{\text{CLR}}$ Pulse Width LOW                   |  | 6.0                               | —    | ns   | 5                       |
| t <sub>REM</sub>                     | Recovery Time $\overline{\text{CLR}}$ to CLK              |  | 6.0                               | —    | ns   | 6                       |
| t <sub>SK(O)</sub>                   | Output Skew <sup>[18]</sup>                               |  | —                                 | 0.5  | ns   | —                       |

**Switching Characteristics** Over the Operating Range<sup>[15]</sup>

| Parameter                            | Description  | Condition <sup>[16]</sup>                                      | CY74FCT16823CT<br>CY74FCT162823CT |      | Unit | Fig.No. <sup>[16]</sup> |
|--------------------------------------|--|--|-----------------------------------|------|------|-------------------------|
|                                      |  |  | Min.                              | Max. |      |                         |
| t <sub>PLH</sub><br>t <sub>PHL</sub> | Propagation Delay<br>CLK to Q                      | C <sub>L</sub> =50 pF<br>R <sub>L</sub> =500Ω                  | 1.5                               | 6.0  | ns   | 1, 5                    |
|                                      |  | C <sub>L</sub> =300 pF <sup>[17]</sup><br>R <sub>L</sub> =500Ω | 1.5                               | 12.5 |      |                         |
| t <sub>PHL</sub>                     | Propagation Delay<br>$\overline{\text{CLR}}$ to Q  | C <sub>L</sub> =50 pF<br>R <sub>L</sub> =500Ω                  | 1.5                               | 6.1  | ns   | 1, 5                    |
| t <sub>PZH</sub><br>t <sub>PZL</sub> | Output Enable Time<br>$\overline{\text{OE}}$ to Q  | C <sub>L</sub> =50 pF<br>R <sub>L</sub> =500Ω                  | 1.5                               | 5.5  | ns   | 1, 7, 8                 |
|                                      |  | C <sub>L</sub> =300 pF <sup>[17]</sup><br>R <sub>L</sub> =500Ω | 1.5                               | 12.5 |      |                         |
| t <sub>PHZ</sub><br>t <sub>PLZ</sub> | Output Disable Time<br>$\overline{\text{OE}}$ to Q | C <sub>L</sub> =5 pF <sup>[17]</sup><br>R <sub>L</sub> =500Ω   | 1.5                               | 5.2  | ns   | 1, 7, 8                 |
|                                      |  | C <sub>L</sub> =50 pF<br>R <sub>L</sub> =500Ω                  | 1.5                               | 6.5  |      |                         |

**Switching Characteristics** Over the Operating Range<sup>[15]</sup> (continued)

| Parameter          | Description  | Condition <sup>[16]</sup>                     | CY74FCT16823CT<br>CY74FCT162823CT |      | Unit | Fig.No. <sup>[16]</sup> |
|--------------------|--|---|-----------------------------------|------|------|-------------------------|
|                    |  |   | Min.                              | Max. |      |                         |
| t <sub>SU</sub>    | Set-Up Time<br>HIGH or LOW, D to CLK                         | C <sub>L</sub> =50 pF<br>R <sub>L</sub> =500Ω | 2.0                               | —    | ns   | 4                       |
| t <sub>H</sub>     | Hold Time<br>HIGH or LOW, D to CLK                           |   | 1.5                               | —    | ns   | 4                       |
| t <sub>SU</sub>    | Set-Up Time<br>HIGH or LOW, $\overline{\text{CLKEN}}$ to CLK |   | 3.0                               | —    | ns   | 9                       |
| t <sub>H</sub>     | Hold Time HIGH or LOW<br>CLKEN to CLK                        |   | 0.0                               | —    | ns   | 9                       |
| t <sub>W</sub>     | CLK Pulse Width<br>HIGH or LOW                               |   | 3.3                               | —    | ns   | 5                       |
| t <sub>W</sub>     | $\overline{\text{CLR}}$ Pulse Width LOW                      |   | 3.3                               | —    | ns   | 5                       |
| t <sub>REM</sub>   | Recovery Time<br>CLR to CLK                                  |   | 6.0                               | —    | ns   | 6                       |
| t <sub>SK(O)</sub> | Output Skew <sup>[18]</sup>                                  |   | —                                 | 0.5  | ns   | —                       |

**Notes:**

15. Minimum limits are specified but not tested on Propagation Delays.  
16. See "Parameter Measurement Information" in the General Information section.  
17. These limits are specified but not tested.  
18. Skew between any two outputs of the same package switching in the same direction. This parameter is ensured by design.

**Ordering Information CY74FCT16823**

| Speed (ns) | Ordering Code          | Package Name | Package Type            | Operating Range |
|------------|------------------------|--------------|-------------------------|-----------------|
| 6.0        | CY74FCT16823CTPACT     | Z56          | 56-Lead (240-Mil) TSSOP | Industrial      |
|            | CY74FCT16823CTPVC/PVCT | O56          | 56-Lead (300-Mil) SSOP  |                 |
| 10.0       | CY74FCT16823ATPACT     | Z56          | 56-Lead (240-Mil) TSSOP | Industrial      |

**Ordering Information CY74FCT162823**

| Speed (ns) | Ordering Code      | Package Name | Package Type            | Operating Range |
|------------|--------------------|--------------|-------------------------|-----------------|
| 6.0        | 74FCT162823CTPACT  | Z56          | 56-Lead (240-Mil) TSSOP | Industrial      |
|            | CY74FCT162823CTPVC | O56          | 56-Lead (300-Mil) SSOP  |                 |
|            | 74FCT162823CTPVCT  | O56          | 56-Lead (300-Mil) SSOP  |                 |
| 10.0       | 74FCT162823ATPACT  | Z56          | 56-Lead (240-Mil) TSSOP | Industrial      |

**Package Diagrams**

**56-Lead Shrunken Small Outline Package O56**

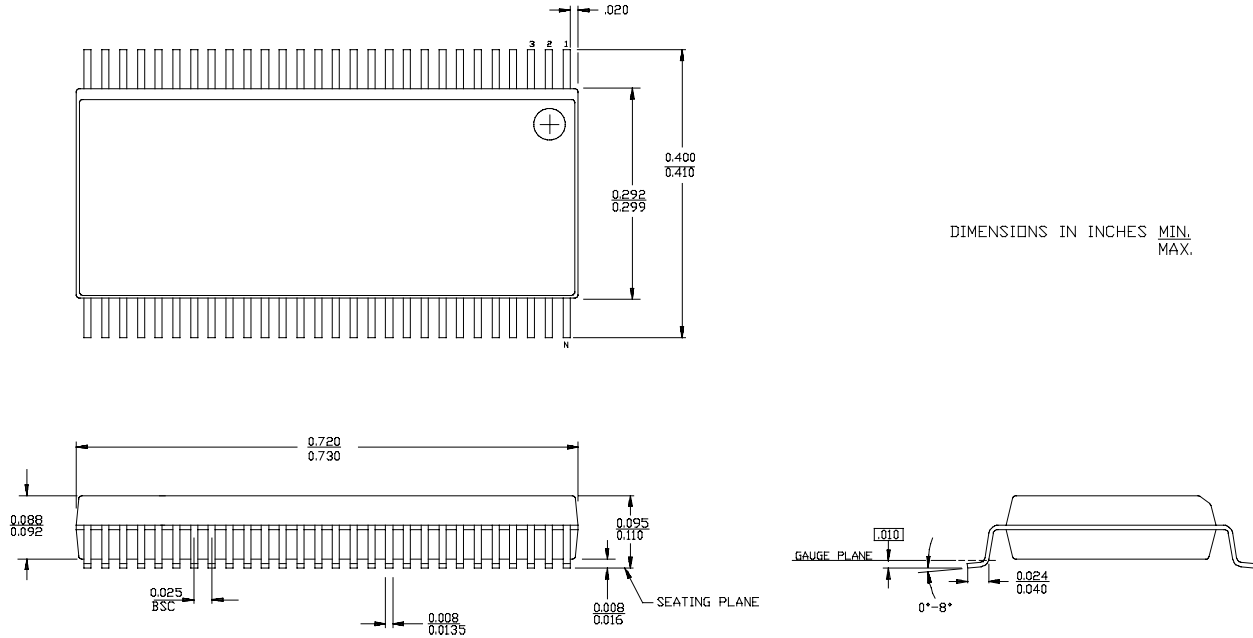

**56-Lead Thin Shrunken Small Outline Package Z56**

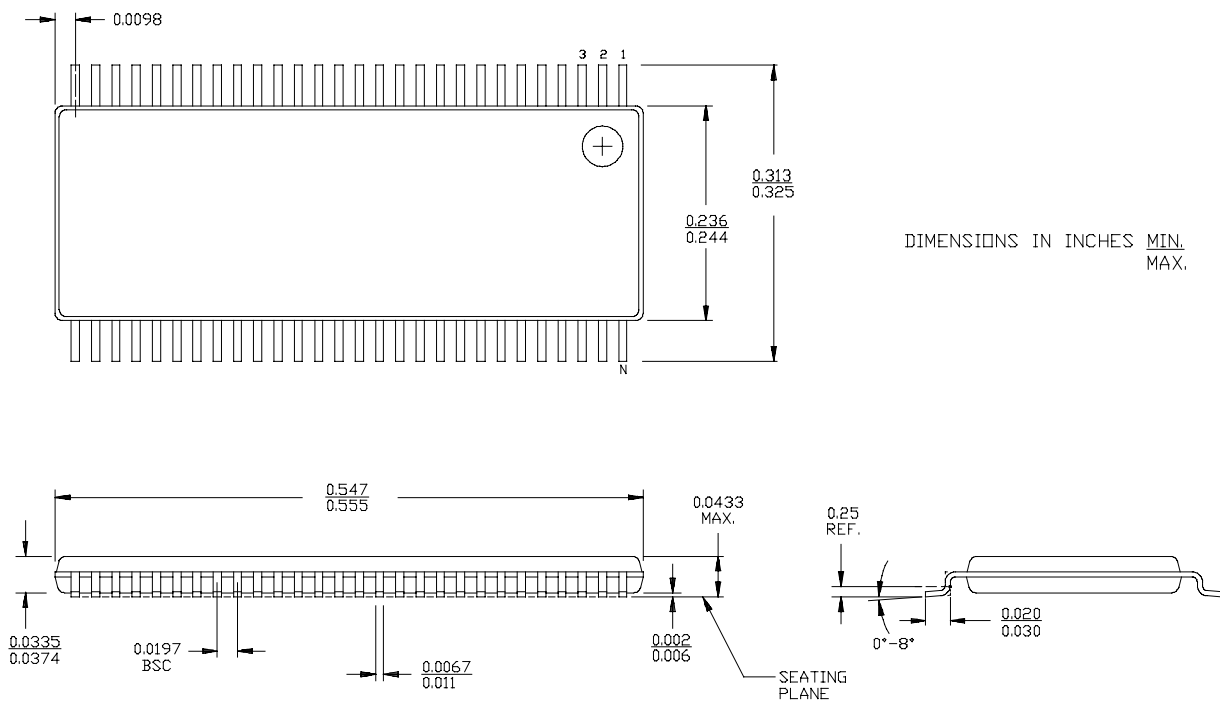

**PACKAGING INFORMATION**

| Orderable Device   | Status <sup>(1)</sup> | Package Type | Package Drawing | Pins | Package Qty | Eco Plan <sup>(2)</sup>    | Lead/<br>Ball Finish | MSL Peak Temp <sup>(3)</sup> | Samples<br>(Requires Login)      |
|--------------------|-----------------------|--------------|-----------------|------|-------------|----------------------------|----------------------|------------------------------|----------------------------------|
| 74FCT162823CTPVCG4 | ACTIVE                | SSOP         | DL              | 56   | 20          | Green (RoHS<br>& no Sb/Br) | CU NIPDAU            | Level-1-260C-UNLIM           | <a href="#">Purchase Samples</a> |
| 74FCT162823CTPVCT  | ACTIVE                | SSOP         | DL              | 56   | 1000        | Green (RoHS<br>& no Sb/Br) | CU NIPDAU            | Level-1-260C-UNLIM           | <a href="#">Purchase Samples</a> |
| 74FCT162823ETPACT  | OBSOLETE              | TSSOP        | DGG             | 56   |             | TBD                        | Call TI              | Call TI                      | Samples Not Available            |
| 74FCT162823ETPVCT  | OBSOLETE              | SSOP         | DL              | 56   |             | TBD                        | Call TI              | Call TI                      | Samples Not Available            |
| 74FCT16823ATPACTE4 | ACTIVE                | TSSOP        | DGG             | 56   | 2000        | Green (RoHS<br>& no Sb/Br) | CU NIPDAU            | Level-1-260C-UNLIM           | <a href="#">Purchase Samples</a> |
| 74FCT16823ATPACTG4 | ACTIVE                | TSSOP        | DGG             | 56   | 2000        | Green (RoHS<br>& no Sb/Br) | CU NIPDAU            | Level-1-260C-UNLIM           | <a href="#">Purchase Samples</a> |
| 74FCT16823CTPACTE4 | ACTIVE                | TSSOP        | DGG             | 56   | 2000        | Green (RoHS<br>& no Sb/Br) | CU NIPDAU            | Level-1-260C-UNLIM           | <a href="#">Purchase Samples</a> |
| 74FCT16823CTPACTG4 | ACTIVE                | TSSOP        | DGG             | 56   | 2000        | Green (RoHS<br>& no Sb/Br) | CU NIPDAU            | Level-1-260C-UNLIM           | <a href="#">Purchase Samples</a> |
| 74FCT16823CTPVCG4  | ACTIVE                | SSOP         | DL              | 56   | 20          | Green (RoHS<br>& no Sb/Br) | CU NIPDAU            | Level-1-260C-UNLIM           | <a href="#">Purchase Samples</a> |
| 74FCT16823CTPVCTG4 | ACTIVE                | SSOP         | DL              | 56   | 1000        | Green (RoHS<br>& no Sb/Br) | CU NIPDAU            | Level-1-260C-UNLIM           | <a href="#">Purchase Samples</a> |
| CY74FCT162823CTPVC | ACTIVE                | SSOP         | DL              | 56   | 20          | Green (RoHS<br>& no Sb/Br) | CU NIPDAU            | Level-1-260C-UNLIM           | <a href="#">Purchase Samples</a> |
| CY74FCT162823ETPAC | OBSOLETE              | TSSOP        | DGG             | 56   |             | TBD                        | Call TI              | Call TI                      | Samples Not Available            |
| CY74FCT162823ETPVC | OBSOLETE              | SSOP         | DL              | 56   |             | TBD                        | Call TI              | Call TI                      | Samples Not Available            |
| CY74FCT16823ATPACT | ACTIVE                | TSSOP        | DGG             | 56   | 2000        | Green (RoHS<br>& no Sb/Br) | CU NIPDAU            | Level-1-260C-UNLIM           | <a href="#">Purchase Samples</a> |
| CY74FCT16823CTPACT | ACTIVE                | TSSOP        | DGG             | 56   | 2000        | Green (RoHS<br>& no Sb/Br) | CU NIPDAU            | Level-1-260C-UNLIM           | <a href="#">Purchase Samples</a> |
| CY74FCT16823CTPVC  | ACTIVE                | SSOP         | DL              | 56   | 20          | Green (RoHS<br>& no Sb/Br) | CU NIPDAU            | Level-1-260C-UNLIM           | <a href="#">Purchase Samples</a> |
| CY74FCT16823CTPVCT | ACTIVE                | SSOP         | DL              | 56   | 1000        | Green (RoHS<br>& no Sb/Br) | CU NIPDAU            | Level-1-260C-UNLIM           | <a href="#">Purchase Samples</a> |
| CY74FCT16823ETPAC  | OBSOLETE              | TSSOP        | DGG             | 56   |             | TBD                        | Call TI              | Call TI                      | Samples Not Available            |
| CY74FCT16823ETPACT | OBSOLETE              | TSSOP        | DGG             | 56   |             | TBD                        | Call TI              | Call TI                      | Samples Not Available            |
| CY74FCT16823ETPVC  | OBSOLETE              | SSOP         | DL              | 56   |             | TBD                        | Call TI              | Call TI                      | Samples Not Available            |

| Orderable Device   | Status <sup>(1)</sup> | Package Type | Package Drawing | Pins | Package Qty | Eco Plan <sup>(2)</sup>    | Lead/<br>Ball Finish | MSL Peak Temp <sup>(3)</sup> | Samples<br>(Requires Login)      |
|--------------------|-----------------------|--------------|-----------------|------|-------------|----------------------------|----------------------|------------------------------|----------------------------------|
| CY74FCT16823ETPVCT | OBSOLETE              | SSOP         | DL              | 56   |             | TBD                        | Call TI              | Call TI                      | Samples Not Available            |
| FCT162823CTPVCTG4  | ACTIVE                | SSOP         | DL              | 56   | 1000        | Green (RoHS<br>& no Sb/Br) | CU NIPDAU            | Level-1-260C-UNLIM           | <a href="#">Purchase Samples</a> |

<sup>(1)</sup> The marketing status values are defined as follows:

**ACTIVE:** Product device recommended for new designs.

**LIFEBUY:** TI has announced that the device will be discontinued, and a lifetime-buy period is in effect.

**NRND:** Not recommended for new designs. Device is in production to support existing customers, but TI does not recommend using this part in a new design.

**PREVIEW:** Device has been announced but is not in production. Samples may or may not be available.

**OBSOLETE:** TI has discontinued the production of the device.

<sup>(2)</sup> Eco Plan - The planned eco-friendly classification: Pb-Free (RoHS), Pb-Free (RoHS Exempt), or Green (RoHS & no Sb/Br) - please check <http://www.ti.com/productcontent> for the latest availability information and additional product content details.

**TBD:** The Pb-Free/Green conversion plan has not been defined.

**Pb-Free (RoHS):** TI's terms "Lead-Free" or "Pb-Free" mean semiconductor products that are compatible with the current RoHS requirements for all 6 substances, including the requirement that lead not exceed 0.1% by weight in homogeneous materials. Where designed to be soldered at high temperatures, TI Pb-Free products are suitable for use in specified lead-free processes.

**Pb-Free (RoHS Exempt):** This component has a RoHS exemption for either 1) lead-based flip-chip solder bumps used between the die and package, or 2) lead-based die adhesive used between the die and leadframe. The component is otherwise considered Pb-Free (RoHS compatible) as defined above.

**Green (RoHS & no Sb/Br):** TI defines "Green" to mean Pb-Free (RoHS compatible), and free of Bromine (Br) and Antimony (Sb) based flame retardants (Br or Sb do not exceed 0.1% by weight in homogeneous material)

<sup>(3)</sup> MSL, Peak Temp. -- The Moisture Sensitivity Level rating according to the JEDEC industry standard classifications, and peak solder temperature.

**Important Information and Disclaimer:** The information provided on this page represents TI's knowledge and belief as of the date that it is provided. TI bases its knowledge and belief on information provided by third parties, and makes no representation or warranty as to the accuracy of such information. Efforts are underway to better integrate information from third parties. TI has taken and continues to take reasonable steps to provide representative and accurate information but may not have conducted destructive testing or chemical analysis on incoming materials and chemicals. TI and TI suppliers consider certain information to be proprietary, and thus CAS numbers and other limited information may not be available for release.

In no event shall TI's liability arising out of such information exceed the total purchase price of the TI part(s) at issue in this document sold by TI to Customer on an annual basis.

**TAPE AND REEL INFORMATION**

**REEL DIMENSIONS**

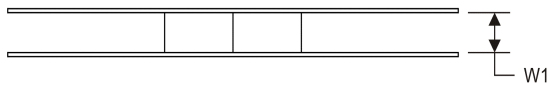
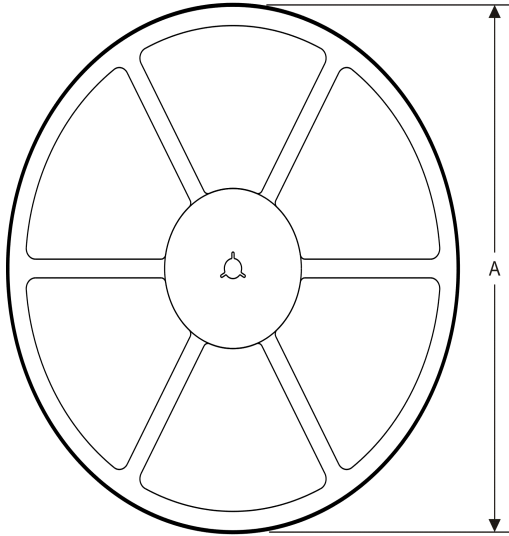

**TAPE DIMENSIONS**

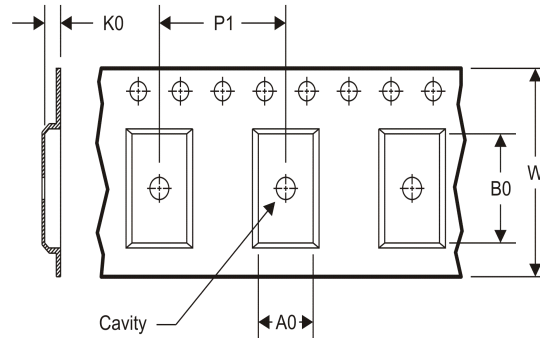

|    |   |
|----|---|
| A0 | Dimension designed to accommodate the component width     |
| B0 | Dimension designed to accommodate the component length    |
| K0 | Dimension designed to accommodate the component thickness |
| W  | Overall width of the carrier tape                         |
| P1 | Pitch between successive cavity centers                   |

**TAPE AND REEL INFORMATION**

\*All dimensions are nominal

| Device             | Package Type | Package Drawing | Pins | SPQ  | Reel Diameter (mm) | Reel Width W1 (mm) | A0 (mm) | B0 (mm) | K0 (mm) | P1 (mm) | W (mm) | Pin1 Quadrant |
|--------------------|--------------|-----------------|------|------|--------------------|--------------------|---------|---------|---------|---------|--------|---------------|
| 74FCT162823CTPVCT  | SSOP         | DL              | 56   | 1000 | 330.0              | 32.4               | 11.35   | 18.67   | 3.1     | 16.0    | 32.0   | Q1            |
| CY74FCT16823ATPACT | TSSOP        | DGG             | 56   | 2000 | 330.0              | 24.4               | 8.6     | 15.6    | 1.8     | 12.0    | 24.0   | Q1            |
| CY74FCT16823CTPACT | TSSOP        | DGG             | 56   | 2000 | 330.0              | 24.4               | 8.6     | 15.6    | 1.8     | 12.0    | 24.0   | Q1            |
| CY74FCT16823CTPVCT | SSOP         | DL              | 56   | 1000 | 330.0              | 32.4               | 11.35   | 18.67   | 3.1     | 16.0    | 32.0   | Q1            |

**TAPE AND REEL BOX DIMENSIONS**



\*All dimensions are nominal

| Device             | Package Type | Package Drawing | Pins | SPQ  | Length (mm) | Width (mm) | Height (mm) |
|--------------------|--------------|-----------------|------|------|-------------|------------|-------------|
| 74FCT162823CTPVCT  | SSOP         | DL              | 56   | 1000 | 367.0       | 367.0      | 55.0        |
| CY74FCT16823ATPACT | TSSOP        | DGG             | 56   | 2000 | 367.0       | 367.0      | 45.0        |
| CY74FCT16823CTPACT | TSSOP        | DGG             | 56   | 2000 | 367.0       | 367.0      | 45.0        |
| CY74FCT16823CTPVCT | SSOP         | DL              | 56   | 1000 | 367.0       | 367.0      | 55.0        |

DL (R-PDSO-G\*\*)

PLASTIC SMALL-OUTLINE PACKAGE

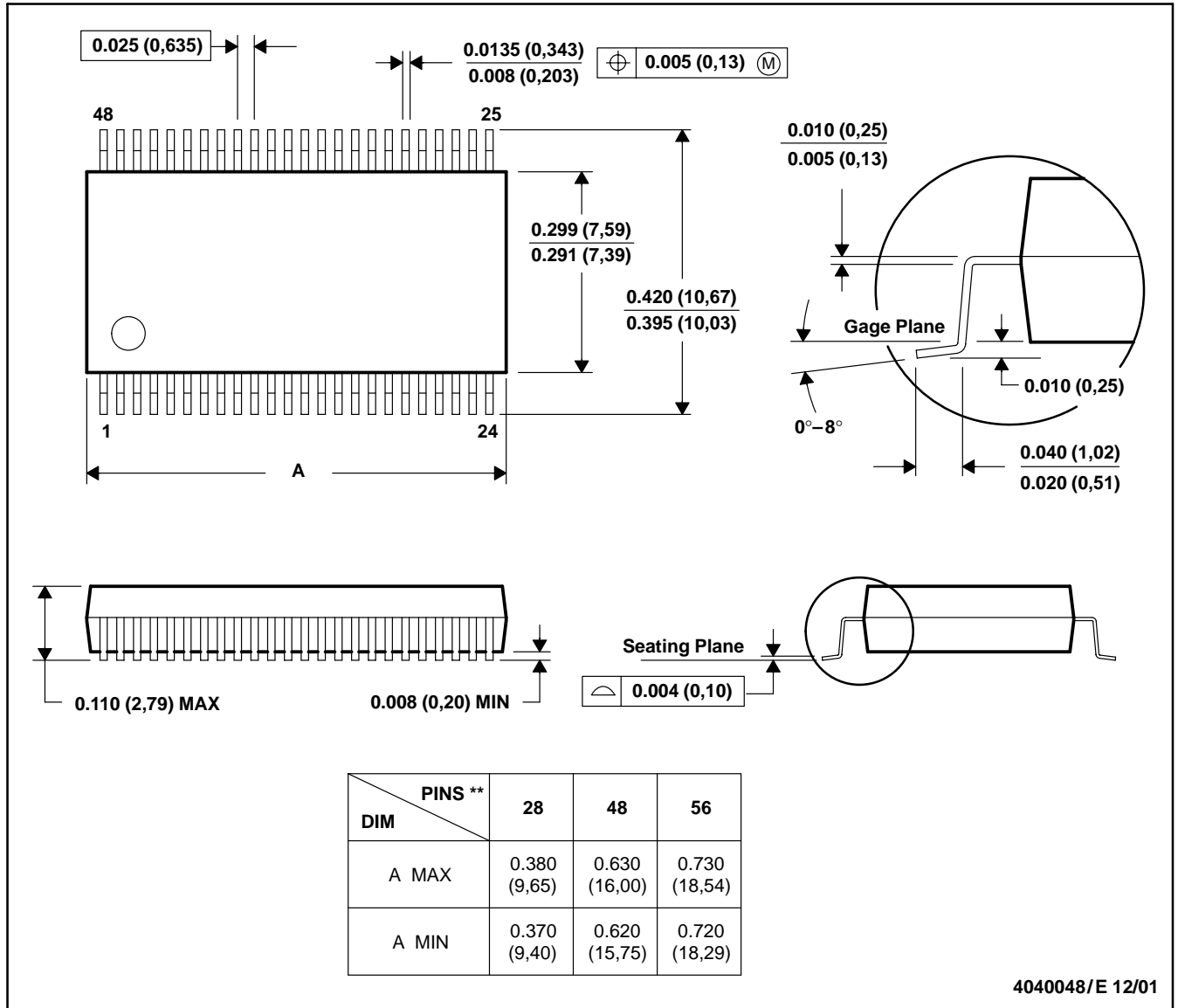
48 PINS SHOWN



- NOTES: A. All linear dimensions are in inches (millimeters).  
 B. This drawing is subject to change without notice.  
 C. Body dimensions do not include mold flash or protrusion not to exceed 0.006 (0,15).  
 D. Falls within JEDEC MO-118

DGG (R-PDSO-G\*\*)

PLASTIC SMALL-OUTLINE PACKAGE

48 PINS SHOWN



- NOTES: A. All linear dimensions are in millimeters.  
 B. This drawing is subject to change without notice.  
 C. Body dimensions do not include mold protrusion not to exceed 0,15.  
 D. Falls within JEDEC MO-153

## IMPORTANT NOTICE

Texas Instruments Incorporated and its subsidiaries (TI) reserve the right to make corrections, enhancements, improvements and other changes to its semiconductor products and services per JESD46C and to discontinue any product or service per JESD48B. Buyers should obtain the latest relevant information before placing orders and should verify that such information is current and complete. All semiconductor products (also referred to herein as "components") are sold subject to TI's terms and conditions of sale supplied at the time of order acknowledgment.

TI warrants performance of its components to the specifications applicable at the time of sale, in accordance with the warranty in TI's terms and conditions of sale of semiconductor products. Testing and other quality control techniques are used to the extent TI deems necessary to support this warranty. Except where mandated by applicable law, testing of all parameters of each component is not necessarily performed.

TI assumes no liability for applications assistance or the design of Buyers' products. Buyers are responsible for their products and applications using TI components. To minimize the risks associated with Buyers' products and applications, Buyers should provide adequate design and operating safeguards.

TI does not warrant or represent that any license, either express or implied, is granted under any patent right, copyright, mask work right, or other intellectual property right relating to any combination, machine, or process in which TI components or services are used. Information published by TI regarding third-party products or services does not constitute a license to use such products or services or a warranty or endorsement thereof. Use of such information may require a license from a third party under the patents or other intellectual property of the third party, or a license from TI under the patents or other intellectual property of TI.

Reproduction of significant portions of TI information in TI data books or data sheets is permissible only if reproduction is without alteration and is accompanied by all associated warranties, conditions, limitations, and notices. TI is not responsible or liable for such altered documentation. Information of third parties may be subject to additional restrictions.

Resale of TI components or services with statements different from or beyond the parameters stated by TI for that component or service voids all express and any implied warranties for the associated TI component or service and is an unfair and deceptive business practice. TI is not responsible or liable for any such statements.

Buyer acknowledges and agrees that it is solely responsible for compliance with all legal, regulatory and safety-related requirements concerning its products, and any use of TI components in its applications, notwithstanding any applications-related information or support that may be provided by TI. Buyer represents and agrees that it has all the necessary expertise to create and implement safeguards which anticipate dangerous consequences of failures, monitor failures and their consequences, lessen the likelihood of failures that might cause harm and take appropriate remedial actions. Buyer will fully indemnify TI and its representatives against any damages arising out of the use of any TI components in safety-critical applications.

In some cases, TI components may be promoted specifically to facilitate safety-related applications. With such components, TI's goal is to help enable customers to design and create their own end-product solutions that meet applicable functional safety standards and requirements. Nonetheless, such components are subject to these terms.

No TI components are authorized for use in FDA Class III (or similar life-critical medical equipment) unless authorized officers of the parties have executed a special agreement specifically governing such use.

Only those TI components which TI has specifically designated as military grade or "enhanced plastic" are designed and intended for use in military/aerospace applications or environments. Buyer acknowledges and agrees that any military or aerospace use of TI components which have **not** been so designated is solely at the Buyer's risk, and that Buyer is solely responsible for compliance with all legal and regulatory requirements in connection with such use.

TI has specifically designated certain components which meet ISO/TS16949 requirements, mainly for automotive use. Components which have not been so designated are neither designed nor intended for automotive use; and TI will not be responsible for any failure of such components to meet such requirements.

### Products

|                        |  |
|------------------------|--|
| Audio                  | <a href="http://www.ti.com/audio">www.ti.com/audio</a>                               |
| Amplifiers             | <a href="http://amplifier.ti.com">amplifier.ti.com</a>                               |
| Data Converters        | <a href="http://dataconverter.ti.com">dataconverter.ti.com</a>                       |
| DLP® Products          | <a href="http://www.dlp.com">www.dlp.com</a>   |
| DSP                    | <a href="http://dsp.ti.com">dsp.ti.com</a>   |
| Clocks and Timers      | <a href="http://www.ti.com/clocks">www.ti.com/clocks</a>                             |
| Interface              | <a href="http://interface.ti.com">interface.ti.com</a>                               |
| Logic                  | <a href="http://logic.ti.com">logic.ti.com</a>                                       |
| Power Mgmt             | <a href="http://power.ti.com">power.ti.com</a>                                       |
| Microcontrollers       | <a href="http://microcontroller.ti.com">microcontroller.ti.com</a>                   |
| RFID                   | <a href="http://www.ti-rfid.com">www.ti-rfid.com</a>                                 |
| OMAP Mobile Processors | <a href="http://www.ti.com/omap">www.ti.com/omap</a>                                 |
| Wireless Connectivity  | <a href="http://www.ti.com/wirelessconnectivity">www.ti.com/wirelessconnectivity</a> |

### Applications

|                               |  |
|-------------------------------|--|
| Automotive and Transportation | <a href="http://www.ti.com/automotive">www.ti.com/automotive</a>                         |
| Communications and Telecom    | <a href="http://www.ti.com/communications">www.ti.com/communications</a>                 |
| Computers and Peripherals     | <a href="http://www.ti.com/computers">www.ti.com/computers</a>                           |
| Consumer Electronics          | <a href="http://www.ti.com/consumer-apps">www.ti.com/consumer-apps</a>                   |
| Energy and Lighting           | <a href="http://www.ti.com/energy">www.ti.com/energy</a>                                 |
| Industrial                    | <a href="http://www.ti.com/industrial">www.ti.com/industrial</a>                         |
| Medical                       | <a href="http://www.ti.com/medical">www.ti.com/medical</a>                               |
| Security                      | <a href="http://www.ti.com/security">www.ti.com/security</a>                             |
| Space, Avionics and Defense   | <a href="http://www.ti.com/space-avionics-defense">www.ti.com/space-avionics-defense</a> |
| Video and Imaging             | <a href="http://www.ti.com/video">www.ti.com/video</a>                                   |

**TI E2E Community** [e2e.ti.com](http://e2e.ti.com)