

# DS14C535

*DS14C535 +5V Supply EIA/TIA-232 3 x 5 Driver/Receiver*



Literature Number: SNLS092B

## DS14C535

### +5V Supply EIA/TIA-232 3 x 5 Driver/Receiver

#### General Description

The DS14C535 is three driver, five receiver device which conforms to EIA/TIA-232-E and CCITT (ITU-T) V.28 standard specifications. This device employs an internal DC-DC converter to generate the necessary output levels from a +5V power supply. A SHUTDOWN (SD) mode reduces the supply current to 10  $\mu$ A maximum. In the SD mode, one receiver is active, allowing ring indicator (RI) to be monitored. PC Board space consumption is minimized by the availability of Shrink Small Outline Packaging (SSOP).

The DS14C535 provides a one-chip solution for the common 9-pin serial RS-232 interface between data terminal and data circuit-terminating equipment.

This device allows an easy migration path to the 3.3V DS14C335. The packages are the same. The N/C pins on the DS14C535 are not physically connected to the chip. Board layout for the DS14C335 will accommodate both devices.

This device's low power requirement and small footprint makes it an ideal choice for Laptop and Notebook applications.

#### Features

- Pin compatible with DS14C335
- Conforms to EIA/TIA-232-E and CCITT (ITU-T) V.28 specifications
- Failsafe receiver outputs high when inputs open
- Operates with single +5V power supply
- Low power requirement— $I_{CC}$  12 mA maximum
- SHUTDOWN mode— $I_{CX}$  10  $\mu$ A maximum
- One Receiver (R5) active during SHUTDOWN
- Operates up to 128 kbps—Lap-Link® Compatible
- 4V/ $\mu$ s minimum Slew Rate guaranteed
- ESD rating of 3 kV on all pins (H, B, M)
- Available in 28-lead SSOP EIAJ Type II package
- Only four 0.1  $\mu$ F capacitors required for the DC-DC converter

#### Connection Diagram

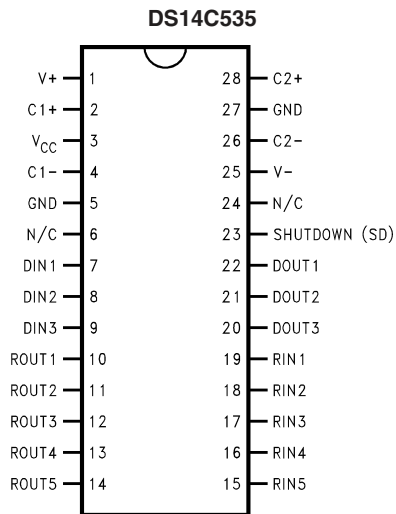

01191001

Order Number **DS14C535MSA**  
See NS Package Number **MSA28**

#### Functional Diagram

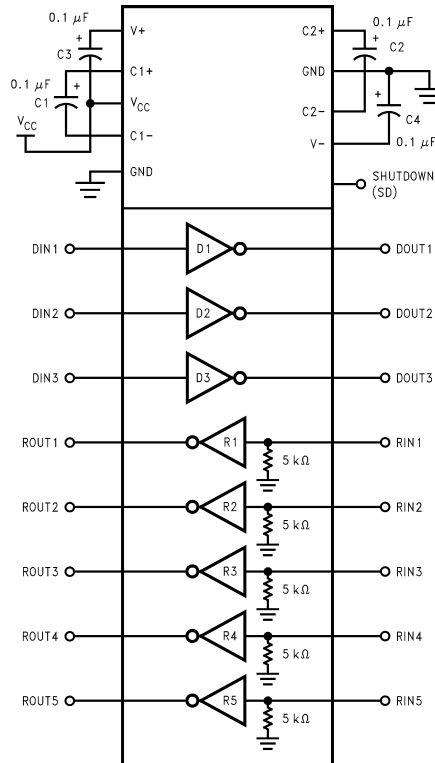

01191002

**Absolute Maximum Ratings** (Note 1)

If Military/Aerospace specified devices are required, please contact the National Semiconductor Sales Office/Distributors for availability and specifications.

Supply Voltage ( $V_{CC}$ )	-0.3V to +6V
$V^+$ Pin	( $V_{CC} - 0.3V$ ) to +14V
$V^-$ Pin	+0.3V to -14V
Input Voltage ( $D_{IN}$ , SD)	-0.3V to +5.5V
Driver Output Voltage	( $V^+ + 0.3V$ ) to ( $V^- - 0.3V$ )
Receiver Input Voltage	$\pm 25V$
Receiver Output Voltage	-0.3V to ( $V_{CC} + 0.3V$ )
Junction Temperature	+150°C
Storage Temperature Range	-65°C to +150°C
Lead Temperature (Soldering 4 sec.)	+260°C
Short Circuit Duration ( $D_{OUT}$ )	Continuous

Maximum Package Power Dissipation @ +25°C

SSOP MSA Package 1286 mW

Derate MSA Package 10.3 mW/°C above +25°C

ESD Rating (HBM, 1.5 k $\Omega$ , 100pF)  $\geq 3.0$  kV**Recommended Operating Conditions**

	Min	Max	Units
Supply Voltage ( $V_{CC}$ )	4.5	5.5	V
Operating Free Air Temperature ( $T_A$ )			
DS14C535	0	+70	°C

DC-DC Converter Capacitors (C1–C4)

Recommended range of values is 0.1  $\mu$ F to 0.68  $\mu$ F,  $\pm 20\%$ .

For more detail refer to application information section of this data sheet.

**Electrical Characteristics** (Notes 2, 3)

Over recommended operating conditions, SD = 0.8V, unless otherwise specified.

Symbol	Parameter	Conditions	Min	Typ	Max	Units
<b>DEVICE CHARACTERISTICS</b>						
$V^+$	Positive Power Supply	No Load		+8.5		V
$V^-$	Negative Power Supply	C1–C4 = 0.1 $\mu$ F		-7.0		V
$I_{CC}$	Supply Current	No Load			12	mA
$I_{CX}$	SHUTDOWN Supply Current	$R_L = 3$ k $\Omega$ , SD = $V_{CC}$		1.0	10	$\mu$ A
$V_{IH}$	High Level Enable Voltage		2.0			V
$V_{IL}$	Low Level Enable Voltage		GND		0.8	V
$I_{IH}$	High Level Enable Current	$2.0V \leq V_{IN} \leq 5.5V$			+2.0	$\mu$ A
$I_{IL}$	Low Level Enable Current	$GND \leq V_{IN} \leq 0.8V$	-2.0			$\mu$ A
<b>DRIVER CHARACTERISTICS</b>						
$V_{IH}$	High Level Input Voltage		2.0			V
$V_{IL}$	Low Level Input Voltage		GND		0.8	V
$I_{IH}$	High Level Input Current	$2.0V \leq V_{IN} \leq 5.5V$			+1.0	$\mu$ A
$I_{IL}$	Low Level Input Current	$GND \leq V_{IN} \leq 0.8V$	-1.0			$\mu$ A
$V_{OH}$	High Level Output Voltage	$R_L = 3$ k $\Omega$	+5.0	8		V
$V_{OL}$	Low Level Output Voltage			-6.7	-5.0	V
$I_{OS+}$	Output High Short Circuit Current	$V_O = 0V$ , $V_{IN} = 0.8V$ (Note 7)	-40	-20	-8	mA
$I_{OS-}$	Output Low Short Circuit Current	$V_O = 0V$ , $V_{IN} = 2.0V$ (Note 7)	6	15	40	mA
$R_O$	Output Resistance	$-2V \leq V_O \leq +2V$ , $V_{CC} = GND = 0V$	300	1200		$\Omega$
<b>RECEIVER CHARACTERISTICS</b> (Note 4)						
$V_{TH}$	Input High Threshold Voltage	R1–R5, SD = 0.8V (Active Mode)		1.4	2.4	V
		R5, $2.0V \leq SD \leq 5.5V$ (Shutdown Mode)		2.0	2.8	V
$V_{TL}$	Input Low Threshold Voltage	R1–R5, SD = 0.8V (Active Mode)	0.8	1.1		V
		R5, $2.0V \leq SD \leq 5.5V$ (Shutdown Mode)	0.8	1.1		V
$V_{HY}$	Hysteresis (Note 4)		0.15		1.0	V
$R_{IN}$	Input Resistance	$V_{IN} = \pm 3V$ to $\pm 15V$	3.0	5.4	7.0	k $\Omega$

## Electrical Characteristics (Notes 2, 3) (Continued)

Over recommended operating conditions,  $SD = 0.8V$ , unless otherwise specified.

Symbol	Parameter	Conditions	Min	Typ	Max	Units
<b>DRIVER CHARACTERISTICS</b>						
$I_{IN}$	Input Current	$V_{IN} = +15V$	2.14		5.0	mA
		$V_{IN} = +3V$	0.43		1.0	mA
		$V_{IN} = -3V$	-1.0		-0.43	mA
		$V_{IN} = -15V$	-5.0		-2.14	mA
$V_{OH}$	High Level Output Voltage	$V_{IN} = -3V, I_{OH} = -2.0 \text{ mA}$	3.8			V
		$V_{IN} = -3V, I_{OH} = -20 \mu A$	4.0			V
$V_{OL}$	Low Level Output Voltage	$V_{IN} = +3V, I_{OL} = +2.0 \text{ mA}$		0.23	0.4	V

## Switching Characteristics (Note 4)

Over recommended operating conditions,  $SD = 0.8V$ , unless otherwise specified.

Symbol	Parameter	Conditions	Min	Typ	Max	Units
<b>DRIVER CHARACTERISTICS</b>						
$t_{PLH}$	Propagation Delay LOW to HIGH	$R_L = 3 \text{ k}\Omega$	0.1	0.6	1.0	$\mu s$
$t_{PHL}$	Propagation Delay HIGH to LOW	$C_L = 50 \text{ pF}$	0.1	0.6	1.0	$\mu s$
$t_{SK}$	Skew $ t_{PLH} - t_{PHL} $	(Figures 1, 2)		0	0.2	$\mu s$
SR1	Output Slew Rate	$R_L = 3 \text{ k}\Omega$ to $7 \text{ k}\Omega, C_L = 50 \text{ pF}$ (Figure 2)	4	13	30	V/ $\mu s$
SR2	Output Slew Rate	$R_L = 3 \text{ k}\Omega, C_L = 2500 \text{ pF}$ (Figure 2)	4	10	30	V/ $\mu s$
$t_{PLS}$	Propagation Delay LOW to SD	(Figures 5, 6)		0.48		ms
$t_{PSL}$	Propagation Delay SD to LOW	$R_L = 3 \text{ k}\Omega$		1.88		ms
$t_{PHS}$	Propagation Delay HIGH to SD	$C_L = 50 \text{ pF}$		0.62		ms
$t_{PSH}$	Propagation Delay SD to HIGH			1.03		ms
<b>RECEIVER CHARACTERISTICS</b>						
$t_{PLH}$	Propagation Delay LOW to HIGH	$C_L = 50 \text{ pF}$	0.1	0.4	1.0	$\mu s$
$t_{PHL}$	Propagation Delay HIGH to LOW	(Figures 3, 4)	0.1	0.6	1.0	$\mu s$
$t_{SK}$	Skew $ t_{PLH} - t_{PHL} $			0.1	0.5	$\mu s$
$t_{PLS}$	Propagation Delay LOW to SD	(Figures 7, 8)		0.13		$\mu s$
$t_{PSL}$	Propagation Delay SD to LOW	$R_L = 1 \text{ k}\Omega$		1.0		$\mu s$
$t_{PHS}$	Propagation Delay HIGH to SD	$C_L = 50 \text{ pF}$		0.19		$\mu s$
$t_{PSH}$	Propagation Delay SD to HIGH	R1–R4 Only		0.58		$\mu s$

**Note 1:** "Absolute Maximum Ratings" are those values beyond which the safety of the device cannot be guaranteed. They are not meant to imply that the devices should be operated at these limits. The tables of "Electrical Characteristics" specify conditions for device operation.

**Note 2:** Typical values are given for  $V_{CC} = 5V$  and  $T_A = +25^\circ C$ .

**Note 3:** Current into device pins is defined as positive. Current out of device pins is defined as negative. All voltages are referenced to ground unless otherwise specified. For voltage logic levels, the more positive value is designated as maximum. For example, if  $-5V$  is a maximum, the typical value ( $-6.7V$ ) is more negative.

**Note 4:** Receiver characteristics are guaranteed for  $SD = 0.8V$ . When  $SD = 2.0V$ , receiver five (R5) is active and meets receiver parameters in SHUTDOWN (SD) mode, unless otherwise specified.

**Note 5:** Generator characteristics for driver input:  $f = 64 \text{ kHz}$  (128 kbits/sec),  $t_r = t_f < 10 \text{ ns}$ ,  $V_{IH} = 3V$ ,  $V_{IL} = 0V$ , duty cycle = 50%.

**Note 6:** Generator characteristics for receiver input:  $f = 64 \text{ kHz}$  (128 kbits/sec),  $t_r = t_f < 10 \text{ ns}$ ,  $V_{IH} = 3V$ ,  $V_{IL} = -3V$ , duty cycle = 50%.

**Note 7:** Only one driver output shorted at a time.

## Parameter Measurement Information

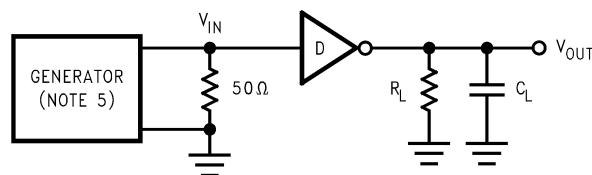

01191003

FIGURE 1. Driver Propagation Delay and Slew Rate Test Circuit

Parameter Measurement Information (Continued)

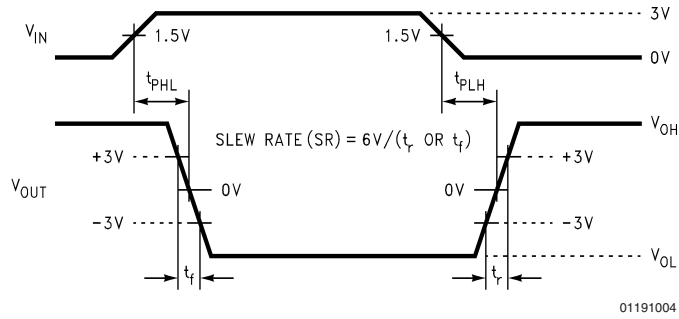

FIGURE 2. Driver Propagation Delay and Slew Rate Timing

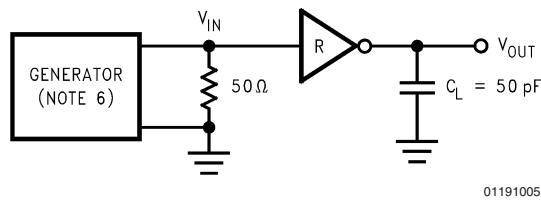

FIGURE 3. Receiver Propagation Delay Test Circuit

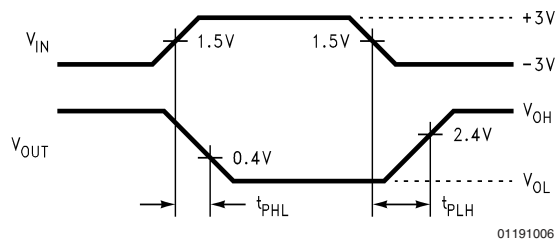

FIGURE 4. Receiver Propagation Delay Timing

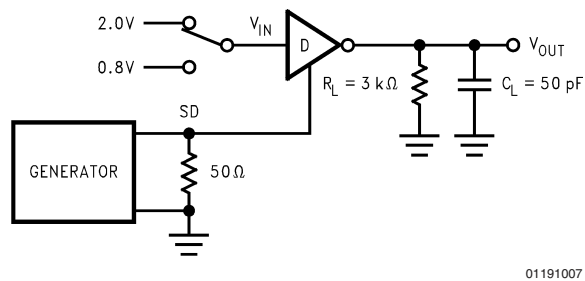

FIGURE 5. Driver SHUTDOWN (SD) Delay Test Circuit

## Parameter Measurement Information (Continued)

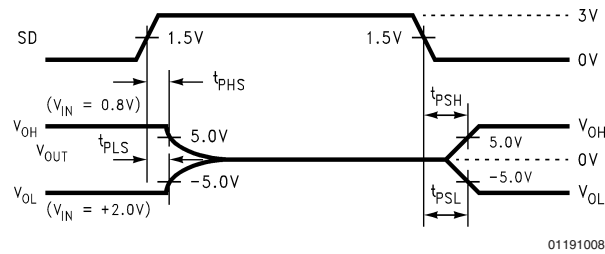

FIGURE 6. Driver SHUTDOWN (SD) Delay Timing

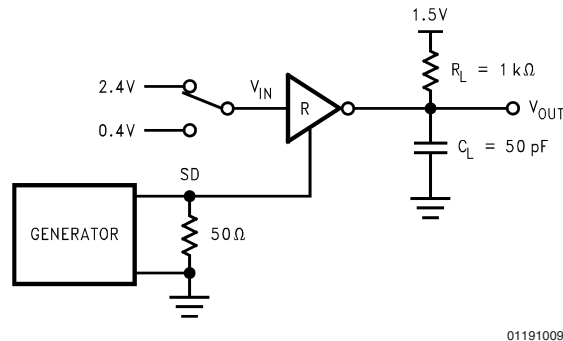

FIGURE 7. Receiver SHUTDOWN (SD) Delay Test Circuit

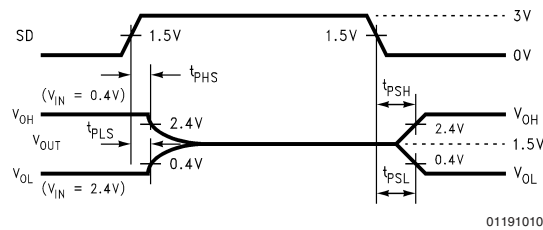

FIGURE 8. Receiver SHUTDOWN (SD) Delay Timing

## Pin Descriptions

**V<sub>CC</sub> (Pin 3).** Power supply pin for the device, +5V (±0.5V).

**V<sub>+</sub> (Pin 1).** Positive supply for EIA/TIA-232-E drivers. Recommended external capacitor—0.1 μF (16V). This supply is not intended to be loaded externally.

**V<sub>-</sub> (Pin 25).** Negative supply for EIA/TIA-232-E drivers. Recommended external capacitor—0.1 μF (16V). This supply is not intended to be loaded externally.

**C1+, C1- (Pins 2, 4).** External capacitor connection pins.

**C2+, C2- (Pins 28, 26).** External capacitor connection pins.

**SHUTDOWN (SD) (Pin 23).** A High on the SHUTDOWN pin will lower the total I<sub>CC</sub> current to less than 10 μA, providing a low power state. In this mode receiver R5 remains active. The SD pin should be driven or tied low (GND) to disable the shutdown mode.

**D<sub>IN</sub> 1–3 (Pins 7, 8, 9).** Driver input pins.

**D<sub>OUT</sub> 1–3 (Pins 22, 21, 20).** Driver output pins conform to EIA/TIA-232 -E levels.

**R<sub>IN</sub> 1–5 (Pins 19, 18, 17, 16, 15).** Receiver input pins accept EIA/TIA-232-E input voltages (±25V). Receivers guarantees hysteresis of TBD mV. Unused receiver input pins may be left open. Internal input resistor (5 kΩ) pulls input LOW, providing a failsafe HIGH output.

**R<sub>OUT</sub> 1–5 (Pins 10, 11, 12, 13, 14).** Receiver output pins.

**GND (Pins 5, 27).** Ground Pins. Both pins must be connected to external ground. These pins are not connected together on the chip.

## Application Information

In a typical Data Terminal Equipment (DTE) to Data Circuit-Terminating Equipment (DCE) 9-pin de-facto interface implementation, 2 data lines and 6 control lines are required. The data lines are TXD and RXD and the control lines are RTS, DTR, DSR, DCD, CTS and RI. The DS14C535 is a 3 x 5 Driver/Receiver and offers a single chip solution for the DTE interface as shown in Figure 9.

Ring Indicator (RI) is used to inform the DTE that an incoming call is coming from a remote DCE. When the DS14C535

**Application Information** (Continued)

is in SHUTDOWN (SD) mode, receiver five (R5) remains active and monitors RI circuit. This active receiver (R5) alerts the DTE to switch the DS14C535 from SHUTDOWN to active mode.

To achieve minimum power consumption, the DS14C535 can be in SHUTDOWN mode and only activated when communications are needed.

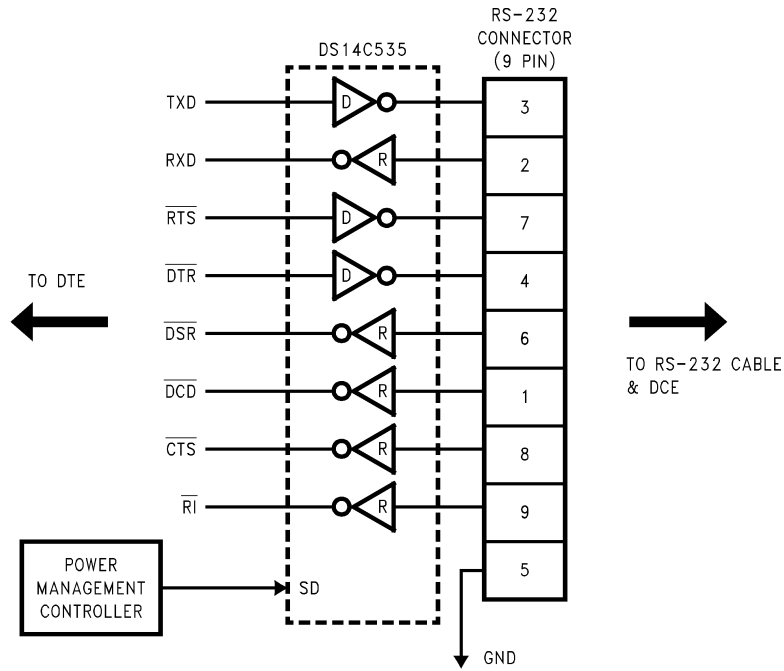

01191011

**FIGURE 9. Typical DTE Application**

## Application Information (Continued)

### CAPACITORS

Capacitors can be ceramic or tantalum. Standard surface mount in the range of 0.1  $\mu\text{F}$  to 0.68  $\mu\text{F}$  are readily available from several manufacturers. A minimum 20V rating is recommended. Contact manufacturers for specific detail on surface mounting and dielectrics. A partial list of manufactur-

ers include:

Manufacturer	Phone Number
KEMET	803-963-6300
AVX	803-448-9411
MURATA-ERIE	800-831-9172

**Physical Dimensions** inches (millimeters) unless otherwise noted

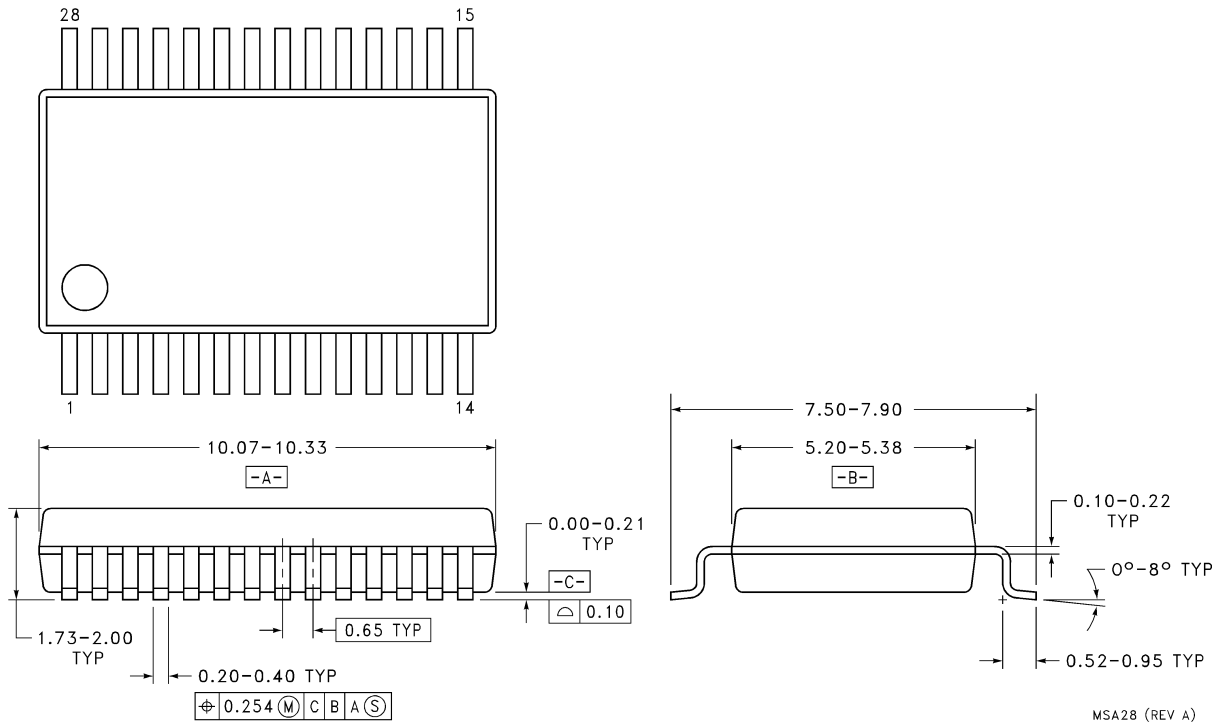

**Order Number DS14C535MSA**  
**NS Package Number MSA28**

**LIFE SUPPORT POLICY**

NATIONAL'S PRODUCTS ARE NOT AUTHORIZED FOR USE AS CRITICAL COMPONENTS IN LIFE SUPPORT DEVICES OR SYSTEMS WITHOUT THE EXPRESS WRITTEN APPROVAL OF THE PRESIDENT AND GENERAL COUNSEL OF NATIONAL SEMICONDUCTOR CORPORATION. As used herein:

1. Life support devices or systems are devices or systems which, (a) are intended for surgical implant into the body, or (b) support or sustain life, and whose failure to perform when properly used in accordance with instructions for use provided in the labeling, can be reasonably expected to result in a significant injury to the user.
2. A critical component is any component of a life support device or system whose failure to perform can be reasonably expected to cause the failure of the life support device or system, or to affect its safety or effectiveness.

**BANNED SUBSTANCE COMPLIANCE**

National Semiconductor certifies that the products and packing materials meet the provisions of the Customer Products Stewardship Specification (CSP-9-111C2) and the Banned Substances and Materials of Interest Specification (CSP-9-111S2) and contain no "Banned Substances" as defined in CSP-9-111S2.



**National Semiconductor**  
**Americas Customer Support Center**  
 Email: new.feedback@nsc.com  
 Tel: 1-800-272-9959

**National Semiconductor**  
**Europe Customer Support Center**  
 Fax: +49 (0) 180-530 85 86  
 Email: europe.support@nsc.com  
 Deutsch Tel: +49 (0) 69 9508 6208  
 English Tel: +44 (0) 870 24 0 2171  
 Français Tel: +33 (0) 1 41 91 8790

**National Semiconductor**  
**Asia Pacific Customer Support Center**  
 Email: ap.support@nsc.com

**National Semiconductor**  
**Japan Customer Support Center**  
 Fax: 81-3-5639-7507  
 Email: jpn.feedback@nsc.com  
 Tel: 81-3-5639-7560

www.national.com

## IMPORTANT NOTICE

Texas Instruments Incorporated and its subsidiaries (TI) reserve the right to make corrections, modifications, enhancements, improvements, and other changes to its products and services at any time and to discontinue any product or service without notice. Customers should obtain the latest relevant information before placing orders and should verify that such information is current and complete. All products are sold subject to TI's terms and conditions of sale supplied at the time of order acknowledgment.

TI warrants performance of its hardware products to the specifications applicable at the time of sale in accordance with TI's standard warranty. Testing and other quality control techniques are used to the extent TI deems necessary to support this warranty. Except where mandated by government requirements, testing of all parameters of each product is not necessarily performed.

TI assumes no liability for applications assistance or customer product design. Customers are responsible for their products and applications using TI components. To minimize the risks associated with customer products and applications, customers should provide adequate design and operating safeguards.

TI does not warrant or represent that any license, either express or implied, is granted under any TI patent right, copyright, mask work right, or other TI intellectual property right relating to any combination, machine, or process in which TI products or services are used. Information published by TI regarding third-party products or services does not constitute a license from TI to use such products or services or a warranty or endorsement thereof. Use of such information may require a license from a third party under the patents or other intellectual property of the third party, or a license from TI under the patents or other intellectual property of TI.

Reproduction of TI information in TI data books or data sheets is permissible only if reproduction is without alteration and is accompanied by all associated warranties, conditions, limitations, and notices. Reproduction of this information with alteration is an unfair and deceptive business practice. TI is not responsible or liable for such altered documentation. Information of third parties may be subject to additional restrictions.

Resale of TI products or services with statements different from or beyond the parameters stated by TI for that product or service voids all express and any implied warranties for the associated TI product or service and is an unfair and deceptive business practice. TI is not responsible or liable for any such statements.

TI products are not authorized for use in safety-critical applications (such as life support) where a failure of the TI product would reasonably be expected to cause severe personal injury or death, unless officers of the parties have executed an agreement specifically governing such use. Buyers represent that they have all necessary expertise in the safety and regulatory ramifications of their applications, and acknowledge and agree that they are solely responsible for all legal, regulatory and safety-related requirements concerning their products and any use of TI products in such safety-critical applications, notwithstanding any applications-related information or support that may be provided by TI. Further, Buyers must fully indemnify TI and its representatives against any damages arising out of the use of TI products in such safety-critical applications.

TI products are neither designed nor intended for use in military/aerospace applications or environments unless the TI products are specifically designated by TI as military-grade or "enhanced plastic." Only products designated by TI as military-grade meet military specifications. Buyers acknowledge and agree that any such use of TI products which TI has not designated as military-grade is solely at the Buyer's risk, and that they are solely responsible for compliance with all legal and regulatory requirements in connection with such use.

TI products are neither designed nor intended for use in automotive applications or environments unless the specific TI products are designated by TI as compliant with ISO/TS 16949 requirements. Buyers acknowledge and agree that, if they use any non-designated products in automotive applications, TI will not be responsible for any failure to meet such requirements.

Following are URLs where you can obtain information on other Texas Instruments products and application solutions:

### Products

Audio	<a href="http://www.ti.com/audio">www.ti.com/audio</a>
Amplifiers	<a href="http://amplifier.ti.com">amplifier.ti.com</a>
Data Converters	<a href="http://dataconverter.ti.com">dataconverter.ti.com</a>
DLP® Products	<a href="http://www.dlp.com">www.dlp.com</a>
DSP	<a href="http://dsp.ti.com">dsp.ti.com</a>
Clocks and Timers	<a href="http://www.ti.com/clocks">www.ti.com/clocks</a>
Interface	<a href="http://interface.ti.com">interface.ti.com</a>
Logic	<a href="http://logic.ti.com">logic.ti.com</a>
Power Mgmt	<a href="http://power.ti.com">power.ti.com</a>
Microcontrollers	<a href="http://microcontroller.ti.com">microcontroller.ti.com</a>
RFID	<a href="http://www.ti-rfid.com">www.ti-rfid.com</a>
OMAP Mobile Processors	<a href="http://www.ti.com/omap">www.ti.com/omap</a>
Wireless Connectivity	<a href="http://www.ti.com/wirelessconnectivity">www.ti.com/wirelessconnectivity</a>

### Applications

Communications and Telecom	<a href="http://www.ti.com/communications">www.ti.com/communications</a>
Computers and Peripherals	<a href="http://www.ti.com/computers">www.ti.com/computers</a>
Consumer Electronics	<a href="http://www.ti.com/consumer-apps">www.ti.com/consumer-apps</a>
Energy and Lighting	<a href="http://www.ti.com/energy">www.ti.com/energy</a>
Industrial	<a href="http://www.ti.com/industrial">www.ti.com/industrial</a>
Medical	<a href="http://www.ti.com/medical">www.ti.com/medical</a>
Security	<a href="http://www.ti.com/security">www.ti.com/security</a>
Space, Avionics and Defense	<a href="http://www.ti.com/space-avionics-defense">www.ti.com/space-avionics-defense</a>
Transportation and Automotive	<a href="http://www.ti.com/automotive">www.ti.com/automotive</a>
Video and Imaging	<a href="http://www.ti.com/video">www.ti.com/video</a>

TI E2E Community Home Page

[e2e.ti.com](http://e2e.ti.com)

Mailing Address: Texas Instruments, Post Office Box 655303, Dallas, Texas 75265  
Copyright © 2011, Texas Instruments Incorporated