

DS36C278 Low Power Multipoint EIA-RS-485 Transceiver

Check for Samples: [DS36C278](#)

FEATURES

- **100% RS-485 Compliant**
 - **Guaranteed RS-485 Device Interoperation**
- **Low Power CMOS Design: I_{CC} 500 μ A Max**
- **Built-In Power Up/Down Glitch-Free Circuitry**
 - **Permits Live Transceiver Insertion/Displacement**
- **PDIP and SOIC Packages Available**
- **Industrial Temperature Range: -40°C to $+85^{\circ}\text{C}$**
- **On-Board Thermal Shutdown Circuitry**
 - **Prevents Damage to the Device in the Event of Excessive Power Dissipation**
- **Wide Common Mode Range: -7V to $+12\text{V}$**
- **Receiver Open Input Fail-Safe ⁽¹⁾**
- **$\frac{1}{4}$ Unit Load (DS36C278): ≥ 12 Nodes**
- **$\frac{1}{2}$ Unit Load (DS36C278T): ≥ 64 Nodes**
- **ESD (Human Body Model): ≥ 2 kV**
- **Drop in Replacement for:**
 - **LTC485, MAX485, DS75176, DS3695**

⁽¹⁾ Non-terminated, open input only

Connection Diagram

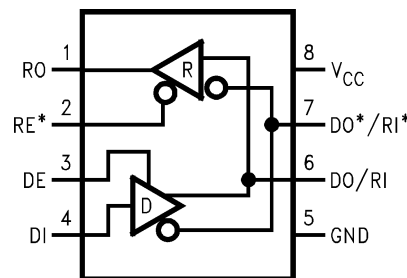

Figure 1. 8-Pin PDIP or SOIC Package Numbers D0008A and P0008E

DESCRIPTION

The DS36C278 is a low power differential bus/line transceiver designed to meet the requirements of RS-485 standard for multipoint data transmission. In addition it is compatible with TIA/EIA-422-B.

The CMOS design offers significant power savings over its bipolar and ALS counterparts without sacrificing ruggedness against ESD damage. The device is ideal for use in battery powered or power conscious applications. I_{CC} is specified at 500 μ A maximum.

The driver and receiver outputs feature TRI-STATE capability. The driver outputs operate over the entire common mode range of -7V to $+12\text{V}$. Bus contention or fault situations that cause excessive power dissipation within the device are handled by a thermal shutdown circuit, which forces the driver outputs into the high impedance state.

The receiver incorporates a fail safe circuit which guarantees a high output state when the inputs are left open. ⁽¹⁾

The DS36C278T is fully specified over the industrial temperature range (-40°C to $+85^{\circ}\text{C}$).



Please be aware that an important notice concerning availability, standard warranty, and use in critical applications of Texas Instruments semiconductor products and disclaimers thereto appears at the end of this data sheet.

All trademarks are the property of their respective owners.

Pin Descriptions

Pin No.	Name	Description
1	RO	Receiver Output: When RE (Receiver Enable) is LOW, the receiver is enabled (ON), if $DO/RI \geq DO^*/RI^*$ by 200 mV, RO will be HIGH. If $DO/RI \leq DO^*/RI^*$ by 200 mV, RO will be LOW. Additionally RO will be HIGH for OPEN (Non-terminated) Inputs.
2	RE*	Receiver Output Enable: When RE* is LOW the receiver output is enabled. When RE* is HIGH, the receiver output is in TRI-STATE (OFF).
3	DE	Driver Output Enable: When DE is HIGH, the driver outputs are enabled. When DE is LOW, the driver outputs are in TRI-STATE (OFF).
4	DI	Driver Input: When DE (Driver Enable) is HIGH, the driver is enabled, if DI is LOW, then DO/RI will be LOW and DO^*/RI^* will be HIGH. If DI is HIGH, then DO/RI is HIGH and DO^*/RI^* is LOW.
5	GND	Ground Connection.
6	DO/RI	Driver Output/Receiver Input, 485 Bus Pin.
7	DO^*/RI^*	Driver Output/Receiver Input, 485 Bus Pin.
8	V_{CC}	Positive Power Supply Connection: Recommended operating range for V_{CC} is +4.75V to +5.25V.

Table 1. Truth Table⁽¹⁾

DRIVER SECTION				
RE*	DE	DI	DO/RI	DO^*/RI^*
X	H	H	H	L
X	H	L	L	H
X	L	X	Z	Z
RECEIVER SECTION				
RE*	DE	RI-RI*	RO	
L	L	$\geq +0.2V$	H	
L	L	$\leq -0.2V$	L	
H	L	X	Z	
L	L	OPEN ⁽¹⁾	H	

(1) Non-terminated, open input only



These devices have limited built-in ESD protection. The leads should be shorted together or the device placed in conductive foam during storage or handling to prevent electrostatic damage to the MOS gates.

Absolute Maximum Ratings⁽¹⁾⁽²⁾

Supply Voltage (V_{CC})	+12V
Input Voltage (DE, RE*, & DI)	-0.5V to ($V_{CC} + 0.5V$)
Common Mode (V_{CM})	
Driver Output/Receiver Input	$\pm 15V$
Input Voltage (DO/RI , DO^*/RI^*)	$\pm 14V$
Receiver Output Voltage	-0.5V to ($V_{CC} + 0.5V$)
Maximum Package Power Dissipation	
@ +25°C	
D0008A Package 1190 mW, derate	9.5 mW/°C above +25°C
P0008E Package 744 mW, derate	6.0 mW/°C above +25°C
Storage Temperature Range	-65°C to +150°C
Lead Temperature (Soldering 4 sec)	+260°C

- (1) "Absolute Maximum Ratings" are those values beyond which the safety of the device cannot be guaranteed. They are not meant to imply that the devices should be operated at these limits. The table of "Electrical Characteristics" specifies conditions of device operation.
- (2) If Military/Aerospace specified devices are required, please contact the TI Sales Office/Distributors for availability and specifications.

Recommended Operating Conditions

	Min	Typ	Max	Units
Supply Voltage (V_{CC})	+4.75	+5.0	+5.25	V
Bus Voltage	-7		+12	V
Operating Free-Air Temperature (T_A)				
DS36C278T	-40	25	+85	°C
DS36C278	0	25	+70	°C

Electrical Characteristics ⁽¹⁾ ⁽²⁾

Over Supply Voltage and Operating Temperature ranges, unless otherwise specified

Parameter		Test Conditions	Reference	Min	Typ	Max	Units	
DIFFERENTIAL DRIVER CHARACTERISTICS								
V_{OD1}	Differential Output Voltage	$I_O = 0$ mA (No Load)	(422) (485)	1.5		5.0	V	
V_{OD0}	Output Voltage	$I_O = 0$ mA		0		5.0	V	
V_{OD0^*}	Output Voltage	(Output to GND)		0		5.0	V	
V_{OD2}	Differential Output Voltage (Termination Load)	$R_L = 50\Omega$	(422)	Figure 2	2.0	2.8	V	
		$R_L = 27\Omega$	(485)		1.5	2.3	5.0	V
ΔV_{OD2}	Balance of V_{OD2} $ V_{OD2} - V_{OD2^*} $	$R_L = 27\Omega$ or 50Ω	(3)		-0.2	0.1	+0.2	V
			(422, 485)					
V_{OD3}	Differential Output Voltage (Full Load)	$R_1 = 54\Omega$, $R_2 = 375\Omega$ $V_{TEST} = -7V$ to $+12V$	Figure 3		1.5	2.0	5.0	V
V_{OC}	Driver Common Mode Output Voltage	$R_L = 27\Omega$	(485)	Figure 2	0		3.0	V
		$R_L = 50\Omega$	(422)		0		3.0	V
ΔV_{OC}	Balance of V_{OC} $ V_{OC} - V_{OC^*} $	$R_L = 27\Omega$ or $R_L = 50\Omega$	(3) (422, 485)		-0.2		+0.2	V
I_{OSD}	Driver Output Short-Circuit Current	$V_O = +12V$	(485)		200	+250	mA	
		$V_O = -7V$	(485)		-190	-250	mA	
RECEIVER CHARACTERISTICS								
V_{TH}	Differential Input High Threshold Voltage	$V_O = V_{OH}$, $I_O = -0.4V$ $-7V \leq V_{CM} \leq +12V$	(4)		+0.035	+0.2	V	
V_{TL}	Differential Input Low Threshold Voltage	$V_O = V_{OL}$, $I_O = 0.4$ mA $-7V \leq V_{CM} \leq +12V$	(422, 485)	-0.2	-0.035		V	
V_{HST}	Hysteresis	$V_{CM} = 0V$	(5)		70		mV	
R_{IN}	Input Resistance	$-7V \leq V_{CM} \leq +12V$	DS36C278T	24	68		k Ω	
R_{IN}	Input Resistance	$-7V \leq V_{CM} \leq +12V$	DS36C278	48	68		k Ω	
I_{IN}	Line Input Current (6)	Other Input = 0V,	DS36C278	$V_{IN} = +12V$	0	0.19	0.25	mA
		$DE = V_{IL}$, $RE^* = V_{IL}$,		$V_{IN} = -7V$	0	-0.1	-0.2	mA
		$V_{CC} = 4.75$ to 5.25	DS36C278T	$V_{IN} = +12V$	0	0.19	0.5	mA
		or 0V		$V_{IN} = -7V$	0	-0.1	-0.4	mA
I_{ING}	Line Input Current Glitch (6)	Other Input = 0V,	DS36C278	$V_{IN} = +12V$	0	0.19	0.25	mA
		$DE = V_{IL}$, $RE^* = V_{IL}$,		$V_{IN} = -7V$	0	-0.1	-0.2	mA
		$V_{CC} = +3.0V$ or $0V$,	DS36C278T	$V_{IN} = +12V$	0	0.19	0.5	mA
		$T_A = 25^\circ C$		$V_{IN} = -7V$	0	-0.1	-0.4	mA
I_B	Input Balance Test	$RS = 500\Omega$	(422) (7)			± 400	mV	

- (1) Current into device pins is defined as positive. Current out of device pins is defined as negative. All voltages are referenced to ground except V_{OD1} and V_{OD2} .
- (2) All typicals are given for: $V_{CC} = +5.0V$, $T_A = +25^\circ C$.
- (3) Delta $|V_{OD2}|$ and Delta $|V_{OC}|$ are changes in magnitude of V_{OD2} and V_{OC} , respectively, that occur when input changes state.
- (4) Threshold parameter limits specified as an algebraic value rather than by magnitude.
- (5) Hysteresis defined as $V_{HST} = V_{TH} - V_{TL}$.
- (6) I_{IN} includes the receiver input current and driver TRI-STATE leakage current.
- (7) For complete details of test, see RS-485.

Electrical Characteristics ⁽¹⁾ ⁽²⁾ (continued)

Over Supply Voltage and Operating Temperature ranges, unless otherwise specified

Parameter		Test Conditions		Reference	Min	Typ	Max	Units
V _{OH}	High Level Output Voltage	I _{OH} = -4 mA, V _{ID} = +0.2V		RO Figure 12	3.5	4.6		V
V _{OL}	Low Level Output Voltage	I _{OL} = +4 mA, V _{ID} = -0.2V				0.3	0.5	V
I _{OSR}	Short Circuit Current	V _O = GND		RO	7	35	85	mA
I _{OZR}	TRI-STATE Leakage Current	V _O = 0.4V to 2.4V					±1	µA
DEVICE CHARACTERISTICS								
V _{IH}	High Level Input Voltage			DE, RE*, DI	2.0		V _{CC}	V
V _{IL}	Low Level Input Voltage				GND		0.8	V
I _{IH}	High Level Input Current	V _{IH} = V _{CC}					2	µA
I _{IL}	Low Level Input Current	V _{CC} = 5V	V _{IL} = 0V				-2	µA
		V _{CC} = +3.0V				-2	µA	
I _{CC}	Power Supply Current	Driver and Receiver ON		V _{CC}		200	500	µA
I _{CCR}	(No Load)	Driver OFF, Receiver ON				200	500	µA
I _{CCD}		Driver ON, Receiver OFF				200	500	µA
I _{CCZ}		Driver and Receiver OFF				200	500	µA

Switching Characteristics ⁽¹⁾ ⁽²⁾

Over Supply Voltage and Operating Temperature ranges, unless otherwise specified

Parameter		Test Conditions		Reference	Min	Typ	Max	Units
DRIVER CHARACTERISTICS								
t _{PHLD}	Differential Propagation Delay High to Low	R _L = 54Ω, C _L = 100 pF		Figure 7	10	39	80	ns
t _{PLHD}	Differential Propagation Delay Low to High				10	40	80	ns
t _{SKD}	Differential Skew t _{PHLD} - t _{PLHD}				0	1	10	ns
t _r	Rise Time				3	25	50	ns
t _f	Fall Time				3	25	50	ns
t _{PHZ}	Disable Time High to Z	C _L = 15 pF		Figure 8, Figure 9	—	80	200	ns
t _{PLZ}	Disable Time Low to Z	RE * = L		Figure 10, Figure 11	—	80	200	ns
t _{PZH}	Enable Time Z to High	C _L = 100 pF		Figure 8, Figure 9	—	50	200	ns
t _{PZL}	Enable Time Z to Low	RE * = L		Figure 10, Figure 11	—	65	200	ns
RECEIVER CHARACTERISTICS								
t _{PHL}	Propagation Delay High to Low	C _L = 15 pF		Figure 13, Figure 14	30	210	400	ns
t _{PLH}	Propagation Delay Low to High				30	190	400	ns
t _{SK}	Skew, t _{PHL} - t _{PLH}				0	20	50	ns
t _{PLZ}	Output Disable Time	C _L = 15 pF		Figure 15, Figure 16, Figure 17	—	50	150	ns
t _{PHZ}					—	55	150	ns
t _{PZL}	Output Enable Time				—	40	150	ns
t _{PZH}					—	45	150	ns

(1) All typicals are given for: V_{CC} = +5.0V, T_A = +25°C.

(2) C_L includes probe and jig capacitance.

PARAMETER MEASUREMENT INFORMATION

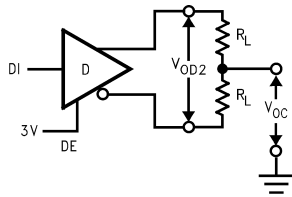

Figure 2. Driver V_{OD2} and V_{OC}

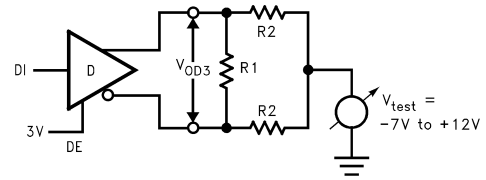
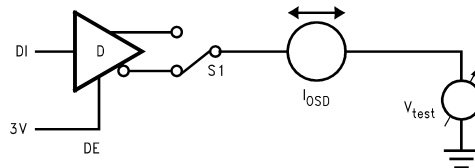

Figure 3. Driver V_{OD3}



Figure 4. Driver V_{OH} and V_{OL}



$V_{test} = -7V$ to $+12V$

Figure 5. Driver I_{0SD}

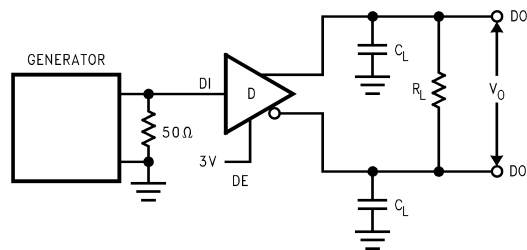

Figure 6. Driver Differential Propagation Delay Test Circuit

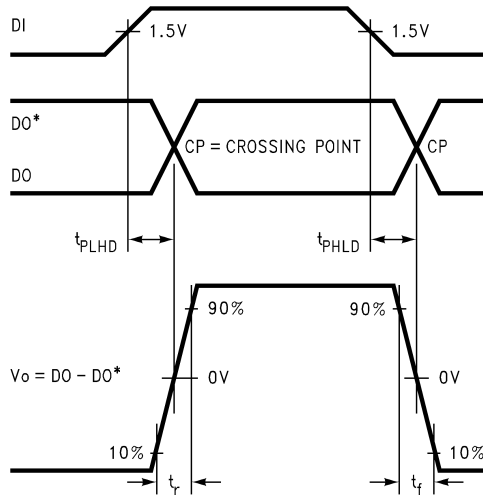

Figure 7. Driver Differential Propagation Delays and Differential Rise and Fall Times

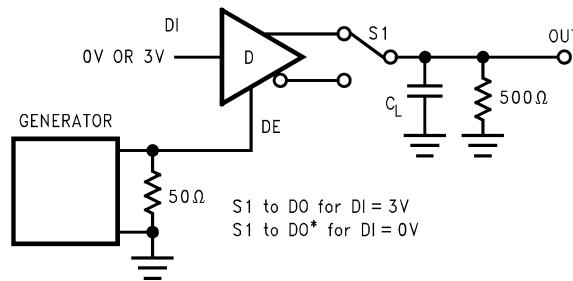

Figure 8. TRI-STATE Test Circuit (t_{PZH} , t_{PHZ})

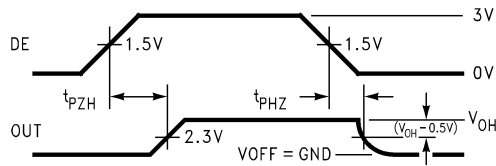

Figure 9. TRI-STATE Waveforms (t_{PZH} , t_{PHZ})

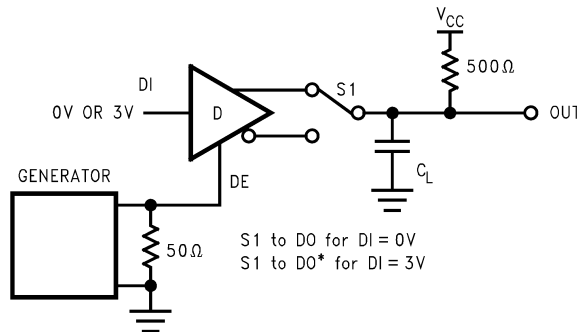

Figure 10. TRI-STATE Test Circuit (t_{PZL} , t_{PLZ})

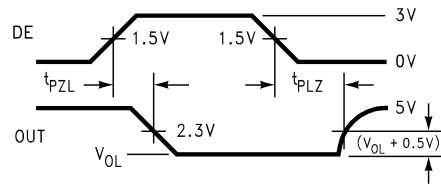

Figure 11. TRI-STATE Waveforms (t_{PZL} , t_{PLZ})

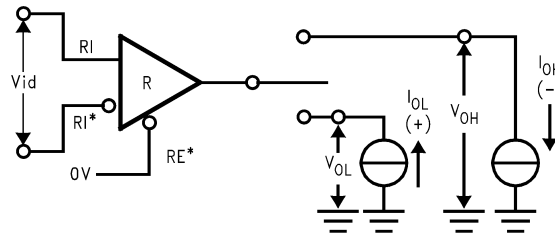

Figure 12. Receiver V_{OH} and V_{OL}

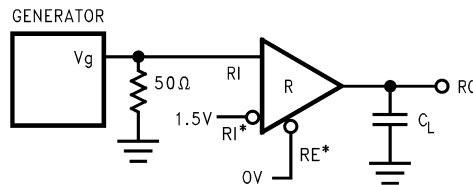

Figure 13. Receiver Differential Propagation Delay Test Circuit

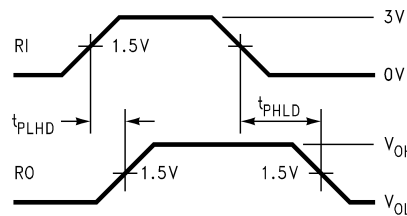

Figure 14. Receiver Differential Propagation Delay Waveforms

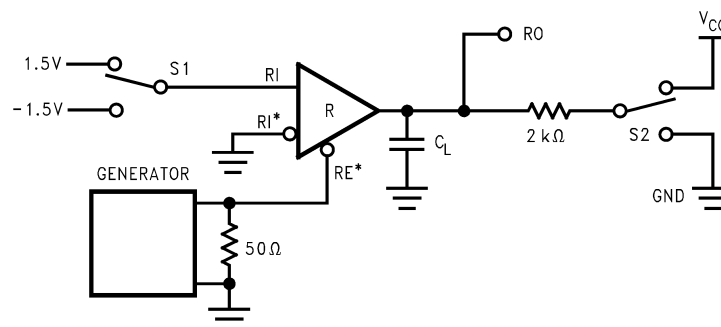

Figure 15. Receiver TRI-STATE Test Circuit

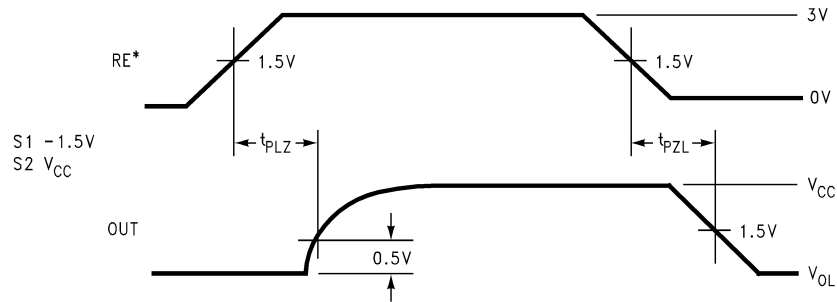

Figure 16. Receiver Enable and Disable Waveforms (t_{PLZ} , t_{PZL})

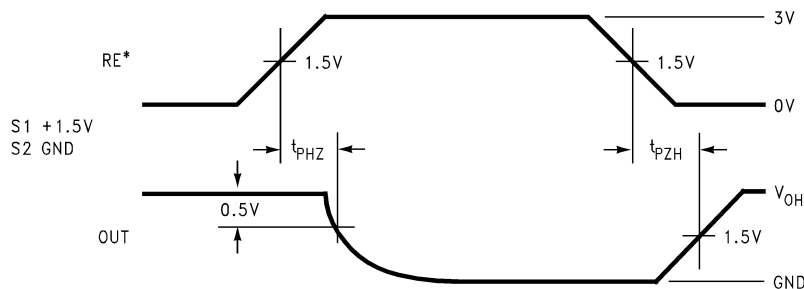

Figure 17. Receiver Enable and Disable Waveforms (t_{PHZ} , t_{PZH})

Typical Application Information

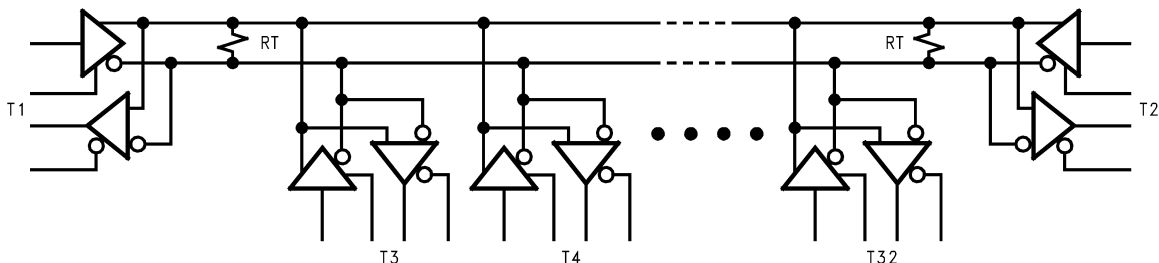

Figure 18. Typical RS-485 Bus Interface

Unit Load

A unit load for an RS-485 receiver is defined by the input current versus the input voltage curve. The gray shaded region is the defined operating range from -7V to $+12\text{V}$. The top border extending from -3V at 0 mA to $+12\text{V}$ at $+1\text{ mA}$ is defined as one unit load. Likewise, the bottom border extending from $+5\text{V}$ at 0 mA to -7V at -0.8 mA is also defined as one unit load (see [Figure 19](#)). An RS-485 driver is capable of driving up to 32 unit loads. This allows up to 32 nodes on a single bus. Although sufficient for many applications, it is sometimes desirable to have even more nodes. For example, an aircraft that has 32 rows with 4 seats per row would benefit from having 128 nodes on one bus. This would allow signals to be transferred to and from each individual seat to 1 main station. Usually there is one or two less seats in the last row of the aircraft near the restrooms and food storage area. This frees the node for the main station.

The DS36C278, the DS36C279, and the DS36C280 all have $\frac{1}{2}$ unit load and $\frac{1}{4}$ unit load (UL) options available. These devices will allow up to 64 nodes or 128 nodes guaranteed over temperature depending upon which option is selected. The $\frac{1}{2}$ UL option is available in industrial temperature and the $\frac{1}{4}$ UL is available in commercial temperature.

First, for a ½ UL device the top and bottom borders shown in Figure 19 are scaled. Both 0 mA reference points at +5V and -3V stay the same. The other reference points are +12V at +0.5 mA for the top border and -7V at -0.4 mA for the bottom border (see Figure 19). Second, for a ¼ UL device the top and bottom borders shown in Figure 19 are scaled also. Again, both 0 mA reference points at +5V and -3V stay the same. The other reference points are +12V at +0.25 mA for the top border and -7V at -0.2 mA for the bottom border (see Figure 19).

The advantage of the ½ UL and ¼ UL devices is the increased number of nodes on one bus. In a single master multi-slave type of application where the number of slaves exceeds 32, the DS36C278/279/280 may save in the cost of extra devices like repeaters, extra media like cable, and/or extra components like resistors.

The DS36C279 and DS36C280 have an additional feature which offers more advantages. The DS36C279 has an automatic sleep mode function for power conscious applications. The DS36C280 has a slew rate control for EMI conscious applications. Refer to the sleep mode and slew rate control portion of the application information section in the corresponding datasheet for more information on these features.

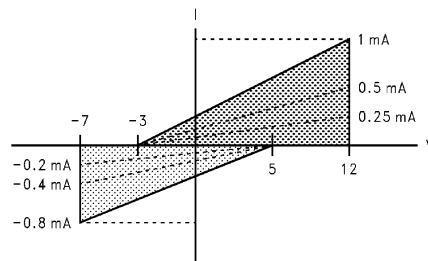





Figure 19. Input Current vs Input Voltage Operating Range

REVISION HISTORY

Changes from Revision B (April 2013) to Revision C	Page
• Changed layout of National Data Sheet to TI format	9

PACKAGING INFORMATION

Orderable Device	Status (1)	Package Type	Package Drawing	Pins	Package Qty	Eco Plan (2)	Lead/Ball Finish (6)	MSL Peak Temp (3)	Op Temp (°C)	Device Marking (4/5)	Samples
DS36C278M/NOPB	ACTIVE	SOIC	D	8	95	Green (RoHS & no Sb/Br)	CU SN	Level-1-260C-UNLIM	0 to 70	DS36C278M	
DS36C278MX/NOPB	ACTIVE	SOIC	D	8	2500	Green (RoHS & no Sb/Br)	CU SN	Level-1-260C-UNLIM	0 to 70	DS36C278M	
DS36C278TM	NRND	SOIC	D	8	95	TBD	Call TI	Call TI	0 to 70	36C278TM	
DS36C278TM/NOPB	ACTIVE	SOIC	D	8	95	Green (RoHS & no Sb/Br)	CU SN	Level-1-260C-UNLIM	0 to 70	36C278TM	
DS36C278TMX	NRND	SOIC	D	8	2500	TBD	Call TI	Call TI	0 to 70	36C278TM	
DS36C278TMX/NOPB	ACTIVE	SOIC	D	8	2500	Green (RoHS & no Sb/Br)	CU SN	Level-1-260C-UNLIM	0 to 70	36C278TM	

(1) The marketing status values are defined as follows:

ACTIVE: Product device recommended for new designs.

LIFEBUY: TI has announced that the device will be discontinued, and a lifetime-buy period is in effect.

NRND: Not recommended for new designs. Device is in production to support existing customers, but TI does not recommend using this part in a new design.

PREVIEW: Device has been announced but is not in production. Samples may or may not be available.

OBSELETE: TI has discontinued the production of the device.

(2) Eco Plan - The planned eco-friendly classification: Pb-Free (RoHS), Pb-Free (RoHS Exempt), or Green (RoHS & no Sb/Br) - please check <http://www.ti.com/productcontent> for the latest availability information and additional product content details.

TBD: The Pb-Free/Green conversion plan has not been defined.

Pb-Free (RoHS): TI's terms "Lead-Free" or "Pb-Free" mean semiconductor products that are compatible with the current RoHS requirements for all 6 substances, including the requirement that lead not exceed 0.1% by weight in homogeneous materials. Where designed to be soldered at high temperatures, TI Pb-Free products are suitable for use in specified lead-free processes.

Pb-Free (RoHS Exempt): This component has a RoHS exemption for either 1) lead-based flip-chip solder bumps used between the die and package, or 2) lead-based die adhesive used between the die and leadframe. The component is otherwise considered Pb-Free (RoHS compatible) as defined above.

Green (RoHS & no Sb/Br): TI defines "Green" to mean Pb-Free (RoHS compatible), and free of Bromine (Br) and Antimony (Sb) based flame retardants (Br or Sb do not exceed 0.1% by weight in homogeneous material)

(3) MSL, Peak Temp. - The Moisture Sensitivity Level rating according to the JEDEC industry standard classifications, and peak solder temperature.

(4) There may be additional marking, which relates to the logo, the lot trace code information, or the environmental category on the device.

(5) Multiple Device Markings will be inside parentheses. Only one Device Marking contained in parentheses and separated by a "~" will appear on a device. If a line is indented then it is a continuation of the previous line and the two combined represent the entire Device Marking for that device.

⁽⁶⁾ Lead/Ball Finish - Orderable Devices may have multiple material finish options. Finish options are separated by a vertical ruled line. Lead/Ball Finish values may wrap to two lines if the finish value exceeds the maximum column width.

Important Information and Disclaimer: The information provided on this page represents TI's knowledge and belief as of the date that it is provided. TI bases its knowledge and belief on information provided by third parties, and makes no representation or warranty as to the accuracy of such information. Efforts are underway to better integrate information from third parties. TI has taken and continues to take reasonable steps to provide representative and accurate information but may not have conducted destructive testing or chemical analysis on incoming materials and chemicals. TI and TI suppliers consider certain information to be proprietary, and thus CAS numbers and other limited information may not be available for release.

In no event shall TI's liability arising out of such information exceed the total purchase price of the TI part(s) at issue in this document sold by TI to Customer on an annual basis.

TAPE AND REEL INFORMATION

QUADRANT ASSIGNMENTS FOR PIN 1 ORIENTATION IN TAPE

*All dimensions are nominal

Device	Package Type	Package Drawing	Pins	SPQ	Reel Diameter (mm)	Reel Width W1 (mm)	A0 (mm)	B0 (mm)	K0 (mm)	P1 (mm)	W (mm)	Pin1 Quadrant
DS36C278MX/NOPB	SOIC	D	8	2500	330.0	12.4	6.5	5.4	2.0	8.0	12.0	Q1
DS36C278TMX	SOIC	D	8	2500	330.0	12.4	6.5	5.4	2.0	8.0	12.0	Q1
DS36C278TMX/NOPB	SOIC	D	8	2500	330.0	12.4	6.5	5.4	2.0	8.0	12.0	Q1

TAPE AND REEL BOX DIMENSIONS

*All dimensions are nominal

Device	Package Type	Package Drawing	Pins	SPQ	Length (mm)	Width (mm)	Height (mm)
DS36C278MX/NOPB	SOIC	D	8	2500	367.0	367.0	35.0
DS36C278TMX	SOIC	D	8	2500	367.0	367.0	35.0
DS36C278TMX/NOPB	SOIC	D	8	2500	367.0	367.0	35.0

D (R-PDSO-G8)

PLASTIC SMALL OUTLINE

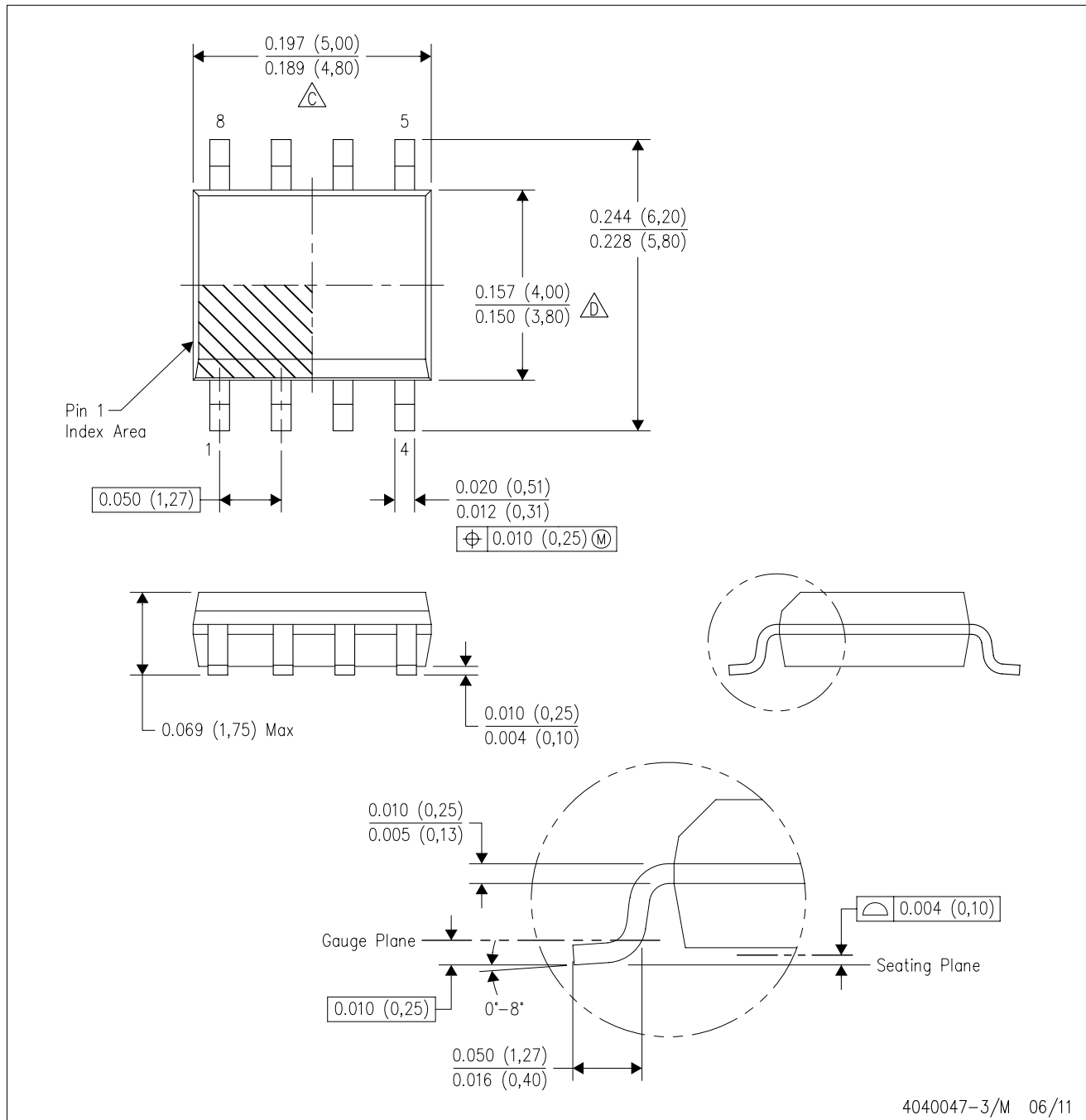

- NOTES:
- A. All linear dimensions are in inches (millimeters).
 - B. This drawing is subject to change without notice.
 - C. Body length does not include mold flash, protrusions, or gate burrs. Mold flash, protrusions, or gate burrs shall not exceed 0.006 (0,15) each side.
 - D. Body width does not include interlead flash. Interlead flash shall not exceed 0.017 (0,43) each side.
 - E. Reference JEDEC MS-012 variation AA.

IMPORTANT NOTICE

Texas Instruments Incorporated and its subsidiaries (TI) reserve the right to make corrections, enhancements, improvements and other changes to its semiconductor products and services per JESD46, latest issue, and to discontinue any product or service per JESD48, latest issue. Buyers should obtain the latest relevant information before placing orders and should verify that such information is current and complete. All semiconductor products (also referred to herein as "components") are sold subject to TI's terms and conditions of sale supplied at the time of order acknowledgment.

TI warrants performance of its components to the specifications applicable at the time of sale, in accordance with the warranty in TI's terms and conditions of sale of semiconductor products. Testing and other quality control techniques are used to the extent TI deems necessary to support this warranty. Except where mandated by applicable law, testing of all parameters of each component is not necessarily performed.

TI assumes no liability for applications assistance or the design of Buyers' products. Buyers are responsible for their products and applications using TI components. To minimize the risks associated with Buyers' products and applications, Buyers should provide adequate design and operating safeguards.

TI does not warrant or represent that any license, either express or implied, is granted under any patent right, copyright, mask work right, or other intellectual property right relating to any combination, machine, or process in which TI components or services are used. Information published by TI regarding third-party products or services does not constitute a license to use such products or services or a warranty or endorsement thereof. Use of such information may require a license from a third party under the patents or other intellectual property of the third party, or a license from TI under the patents or other intellectual property of TI.

Reproduction of significant portions of TI information in TI data books or data sheets is permissible only if reproduction is without alteration and is accompanied by all associated warranties, conditions, limitations, and notices. TI is not responsible or liable for such altered documentation. Information of third parties may be subject to additional restrictions.

Resale of TI components or services with statements different from or beyond the parameters stated by TI for that component or service voids all express and any implied warranties for the associated TI component or service and is an unfair and deceptive business practice. TI is not responsible or liable for any such statements.

Buyer acknowledges and agrees that it is solely responsible for compliance with all legal, regulatory and safety-related requirements concerning its products, and any use of TI components in its applications, notwithstanding any applications-related information or support that may be provided by TI. Buyer represents and agrees that it has all the necessary expertise to create and implement safeguards which anticipate dangerous consequences of failures, monitor failures and their consequences, lessen the likelihood of failures that might cause harm and take appropriate remedial actions. Buyer will fully indemnify TI and its representatives against any damages arising out of the use of any TI components in safety-critical applications.

In some cases, TI components may be promoted specifically to facilitate safety-related applications. With such components, TI's goal is to help enable customers to design and create their own end-product solutions that meet applicable functional safety standards and requirements. Nonetheless, such components are subject to these terms.

No TI components are authorized for use in FDA Class III (or similar life-critical medical equipment) unless authorized officers of the parties have executed a special agreement specifically governing such use.

Only those TI components which TI has specifically designated as military grade or "enhanced plastic" are designed and intended for use in military/aerospace applications or environments. Buyer acknowledges and agrees that any military or aerospace use of TI components which have **not** been so designated is solely at the Buyer's risk, and that Buyer is solely responsible for compliance with all legal and regulatory requirements in connection with such use.

TI has specifically designated certain components as meeting ISO/TS16949 requirements, mainly for automotive use. In any case of use of non-designated products, TI will not be responsible for any failure to meet ISO/TS16949.

Products

Audio	www.ti.com/audio
Amplifiers	amplifier.ti.com
Data Converters	dataconverter.ti.com
DLP® Products	www.dlp.com
DSP	dsp.ti.com
Clocks and Timers	www.ti.com/clocks
Interface	interface.ti.com
Logic	logic.ti.com
Power Mgmt	power.ti.com
Microcontrollers	microcontroller.ti.com
RFID	www.ti-rfid.com
OMAP Applications Processors	www.ti.com/omap
Wireless Connectivity	www.ti.com/wirelessconnectivity

Applications

Automotive and Transportation	www.ti.com/automotive
Communications and Telecom	www.ti.com/communications
Computers and Peripherals	www.ti.com/computers
Consumer Electronics	www.ti.com/consumer-apps
Energy and Lighting	www.ti.com/energy
Industrial	www.ti.com/industrial
Medical	www.ti.com/medical
Security	www.ti.com/security
Space, Avionics and Defense	www.ti.com/space-avionics-defense
Video and Imaging	www.ti.com/video

TI E2E Community

e2e.ti.com