

INA134 INA2134

AUDIO DIFFERENTIAL LINE RECEIVERS 0dB (G = 1)

FEATURES

- SINGLE AND DUAL VERSIONS
- LOW DISTORTION: 0.0005% at $f = 1\text{kHz}$
- HIGH SLEW RATE: $14\text{V}/\mu\text{s}$
- FAST SETTLING TIME: $3\mu\text{s}$ to 0.01%
- WIDE SUPPLY RANGE: $\pm 4\text{V}$ to $\pm 18\text{V}$
- LOW QUIESCENT CURRENT: 2.9mA max
- HIGH CMRR: 90dB
- FIXED GAIN = 0dB (1V/V)
- PACKAGES—SINGLE: 8-PIN DIP, SO-8
DUAL: 14-PIN DIP, SO-14

DESCRIPTION

The INA134 and INA2134 are differential line receivers consisting of high performance op amps with on-chip precision resistors. They are fully specified for high performance audio applications and have excellent ac specifications, including low distortion (0.0005% at 1kHz) and high slew rate ($14\text{V}/\mu\text{s}$), assuring good dynamic response. In addition, wide output voltage swing and high output drive capability allow use in a wide variety of demanding applications. The dual version features completely independent circuitry for lowest crosstalk and freedom from interaction, even when overdriven or overloaded.

The INA134 and INA2134 on-chip resistors are laser trimmed for accurate gain and optimum common-mode rejection. Furthermore, excellent TCR tracking of the resistors maintains gain accuracy and common-mode rejection over temperature. Operation is guaranteed from $\pm 4\text{V}$ to $\pm 18\text{V}$ (8V to 36V total supply).

The INA134 is available in 8-pin DIP and SO-8 surface-mount packages. The INA2134 comes in 14-pin DIP and SO-14 surface-mount packages. Both are specified for operation over the extended industrial temperature range, -40°C to $+85^\circ\text{C}$.

APPLICATIONS

- AUDIO DIFFERENTIAL LINE RECEIVER
- SUMMING AMPLIFIER
- UNITY-GAIN INVERTING AMPLIFIER
- PSEUDOGROUND GENERATOR
- INSTRUMENTATION BUILDING BLOCK
- CURRENT SHUNT MONITOR
- VOLTAGE-CONTROLLED CURRENT SOURCE
- GROUND LOOP ELIMINATOR

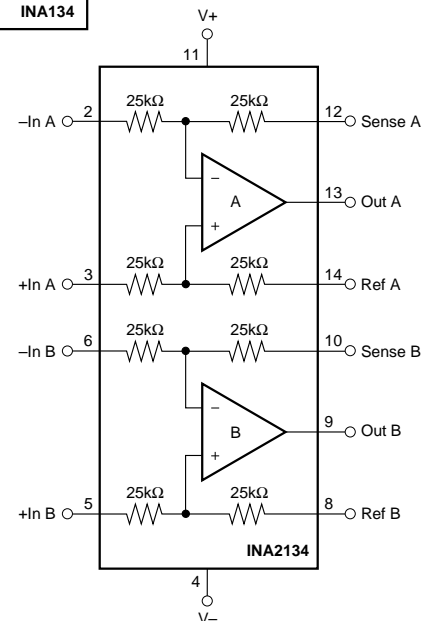
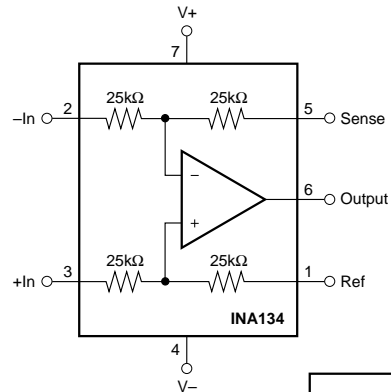

SPECIFICATIONS: $V_S = \pm 18V$

At $T_A = +25^\circ C$, $V_S = \pm 18V$, $R_L = 2k\Omega$, and Ref Pin connected to Ground, unless otherwise noted.

PARAMETER	CONDITIONS	INA134PA, UA INA2134PA, UA			UNITS
		MIN	TYP	MAX	
AUDIO PERFORMANCE Total Harmonic Distortion + Noise, $f = 1kHz$ Noise Floor ⁽¹⁾ Headroom ⁽¹⁾	$V_{IN} = 10V_{rms}$ 20kHz BW THD+N < 1%		0.0005 -100 +23		% dBu dBu
FREQUENCY RESPONSE Small-Signal Bandwidth Slew Rate Settling Time: 0.1% 0.01% Overload Recovery Time Channel Separation (dual), $f = 1kHz$	10V Step, $C_L = 100pF$ 10V Step, $C_L = 100pF$ 50% Overdrive		3.1 14 2 3 3 117		MHz V/ μs μs μs μs dB
OUTPUT NOISE VOLTAGE⁽²⁾ $f = 20Hz$ to 20kHz $f = 1kHz$			7 52		μV_{rms} nV/ \sqrt{Hz}
OFFSET VOLTAGE⁽³⁾ Input Offset Voltage vs Temperature vs Power Supply	$V_{CM} = 0V$ Specified Temperature Range $V_S = \pm 4V$ to $\pm 18V$		± 100 ± 2 ± 5	± 1000 ± 60	μV $\mu V/^\circ C$ $\mu V/V$
INPUT Common-Mode Voltage Range: Positive Negative Differential Voltage Range Common-Mode Rejection Impedance ⁽⁴⁾ Differential Common-Mode	$V_O = 0V$ $V_O = 0V$ $V_{CM} = \pm 31V$, $R_S = 0\Omega$	2(V+)-5 2(V-)+5 74	2(V+)-4 2(V-)+2 See Typical Curve 90 50 50		V V dB k Ω k Ω
GAIN Initial Error vs Temperature Nonlinearity	$V_O = -16V$ to 16V $V_O = -16V$ to 16V		1 ± 0.02 ± 1 0.0001	± 0.1 ± 10	V/V % ppm/ $^\circ C$ %
OUTPUT Voltage Output, Positive Negative Current Limit, Continuous to Common Capacitive Load (Stable Operation)		(V+)-2 (V-)+2	(V+)-1.8 (V-)+1.6 ± 60 500		V V mA pF
POWER SUPPLY Rated Voltage Voltage Range Quiescent Current (per Amplifier)	$I_O = 0$	± 4	± 18 ± 2.4	± 18 ± 2.9	V V mA
TEMPERATURE RANGE Specification Range Operation Range Storage Range Thermal Resistance, θ_{JA} 8-Pin DIP SO-8 Surface-Mount 14-Pin DIP SO-14 Surface-Mount		-40 -55 -55		85 125 125	$^\circ C$ $^\circ C$ $^\circ C$ $^\circ C/W$ $^\circ C/W$ $^\circ C/W$ $^\circ C/W$

NOTES: (1) dBu = 20log (Vrms/0.7746). (2) Includes effects of amplifier's input current noise and thermal noise contribution of resistor network. (3) Includes effects of amplifier's input bias and offset currents. (4) 25k Ω resistors are ratio matched but have $\pm 25\%$ absolute value.

The information provided herein is believed to be reliable; however, BURR-BROWN assumes no responsibility for inaccuracies or omissions. BURR-BROWN assumes no responsibility for the use of this information, and all use of such information shall be entirely at the user's own risk. Prices and specifications are subject to change without notice. No patent rights or licenses to any of the circuits described herein are implied or granted to any third party. BURR-BROWN does not authorize or warrant any BURR-BROWN product for use in life support devices and/or systems.

PIN CONFIGURATIONS

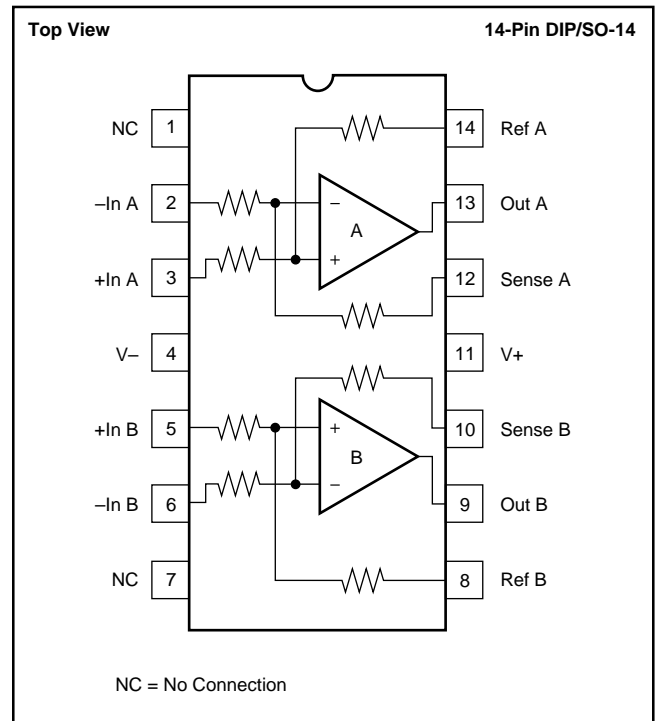
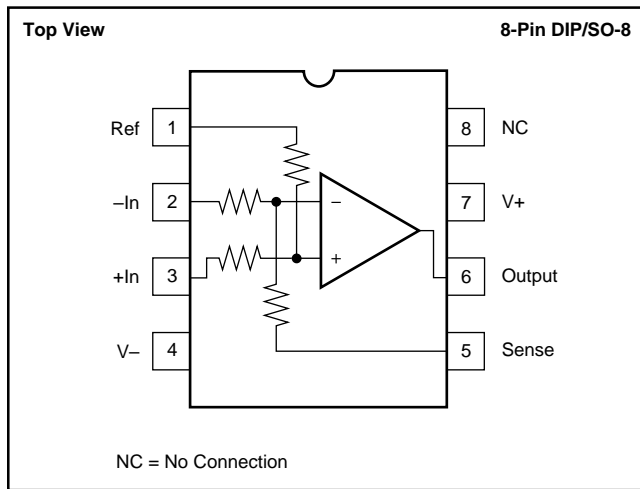

ABSOLUTE MAXIMUM RATINGS⁽¹⁾

Supply Voltage, V+ to V-	40V
Input Voltage Range	±80V
Output Short-Circuit (to ground) ⁽²⁾	Continuous
Operating Temperature	-55°C to +125°C
Storage Temperature	-55°C to +125°C
Junction Temperature	+150°C
Lead Temperature (soldering, 10s)	+300°C

NOTE: (1) Stresses above these ratings may cause permanent damage.
 (2) One channel per package.

PACKAGE/ORDERING INFORMATION

PRODUCT	PACKAGE	PACKAGE DRAWING NUMBER ⁽¹⁾	SPECIFICATION TEMPERATURE RANGE
Single			
INA134PA	8-Pin DIP	006	-40°C to +85°C
INA134UA	SO-8 Surface-Mount	182	-40°C to +85°C
Dual			
INA2134PA	14-Pin DIP	010	-40°C to +85°C
INA2134UA	SO-14 Surface-Mount	235	-40°C to +85°C

NOTE: (1) For detailed drawing and dimension table, please see end of data sheet, or Appendix C of Burr-Brown IC Data Book.



ELECTROSTATIC DISCHARGE SENSITIVITY

This integrated circuit can be damaged by ESD. Burr-Brown recommends that all integrated circuits be handled with appropriate precautions. Failure to observe proper handling and installation procedures can cause damage.

ESD damage can range from subtle performance degradation to complete device failure. Precision integrated circuits may be more susceptible to damage because very small parametric changes could cause the device not to meet its published specifications.

TYPICAL PERFORMANCE CURVES

At $T_A = +25^\circ\text{C}$, $V_S = \pm 18\text{V}$, unless otherwise noted.

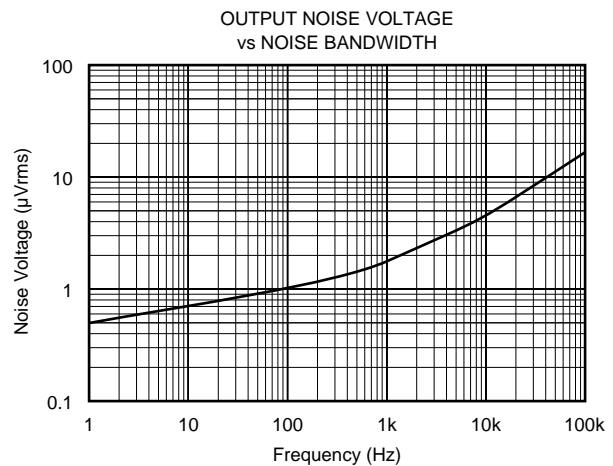
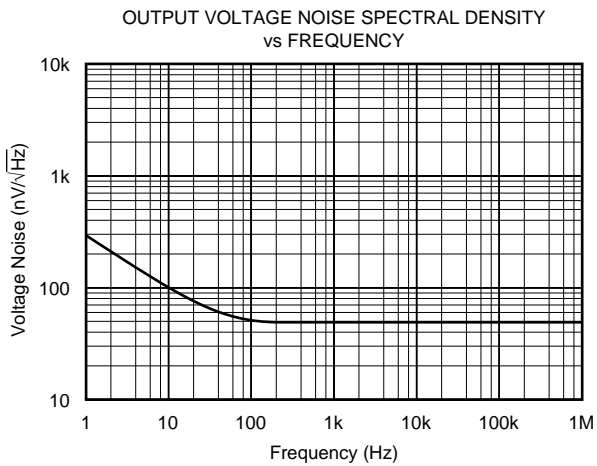
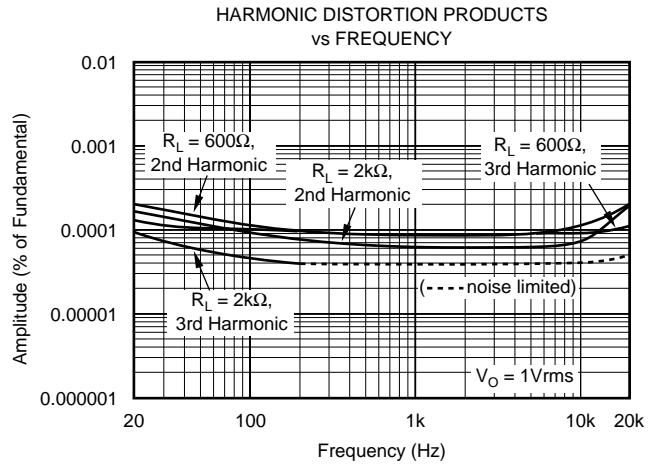
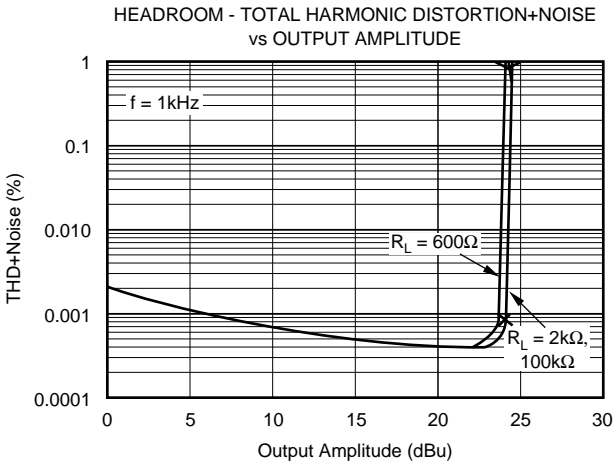
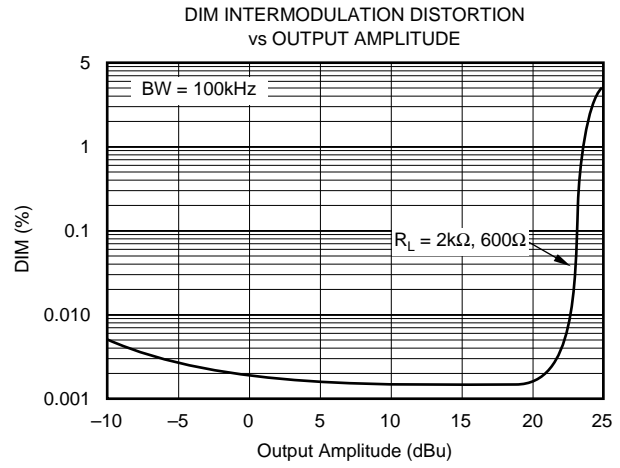
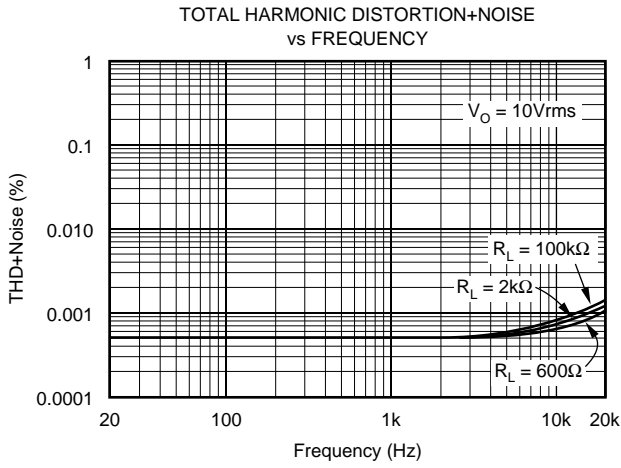

TYPICAL PERFORMANCE CURVES (CONT)

At $T_A = +25^\circ\text{C}$, $V_S = \pm 18\text{V}$, unless otherwise noted.

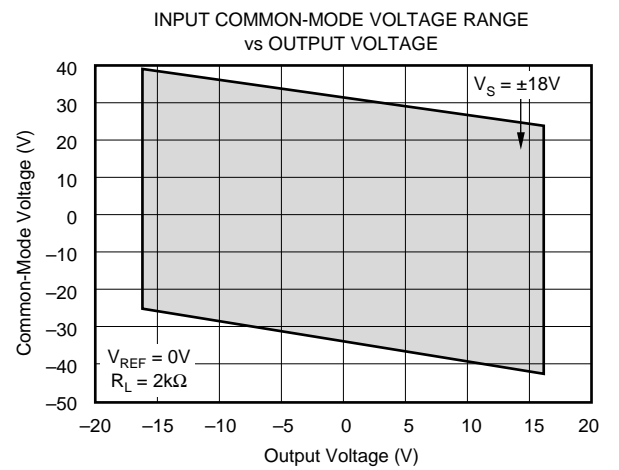
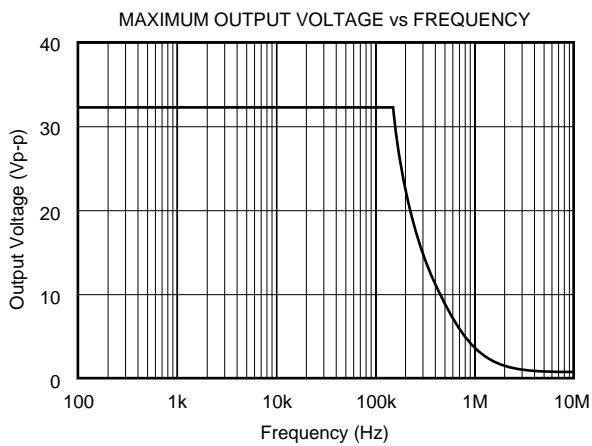
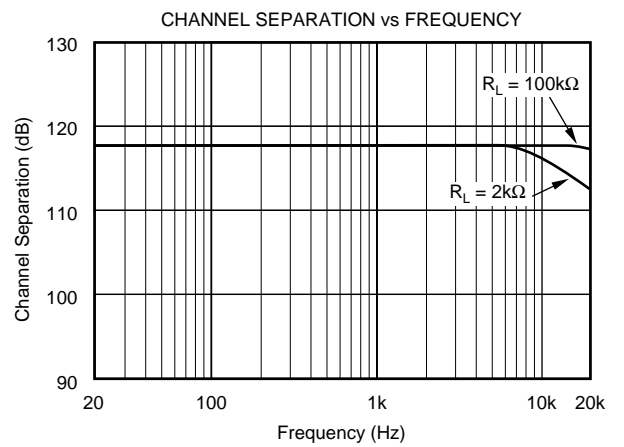
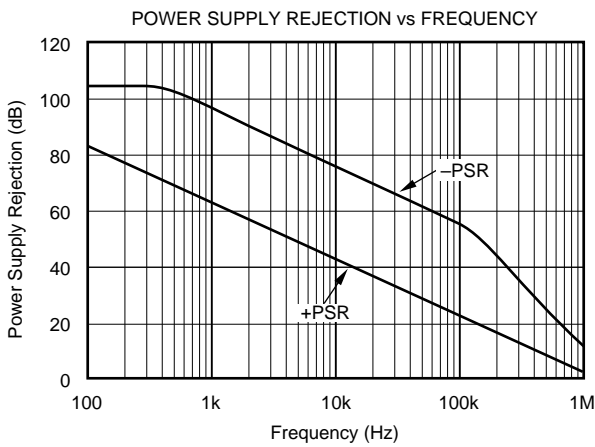
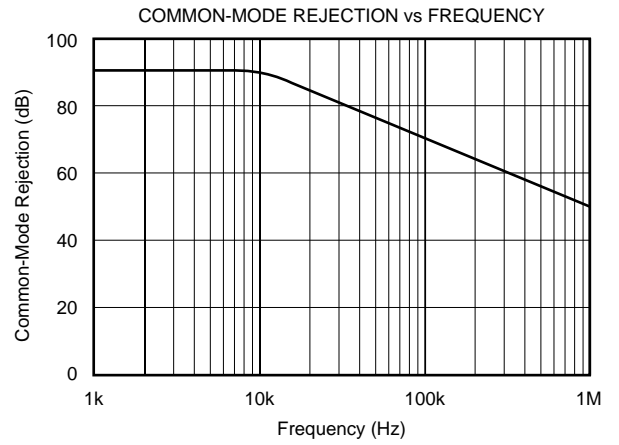
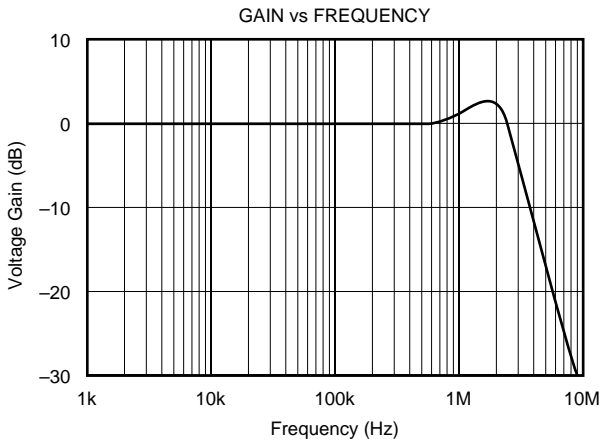

TYPICAL PERFORMANCE CURVES (CONT)

At $T_A = +25^\circ\text{C}$, $V_S = \pm 18\text{V}$, unless otherwise noted.

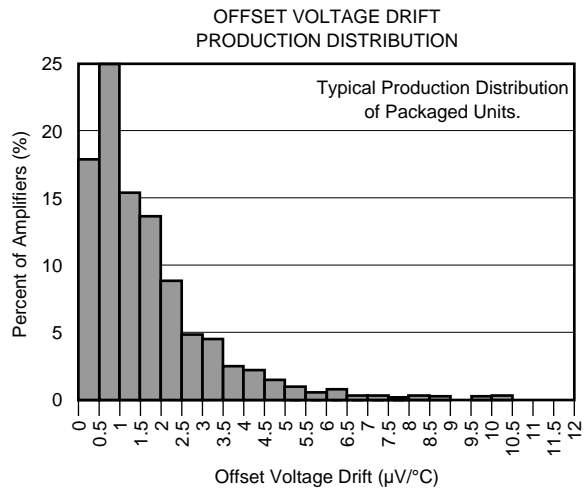
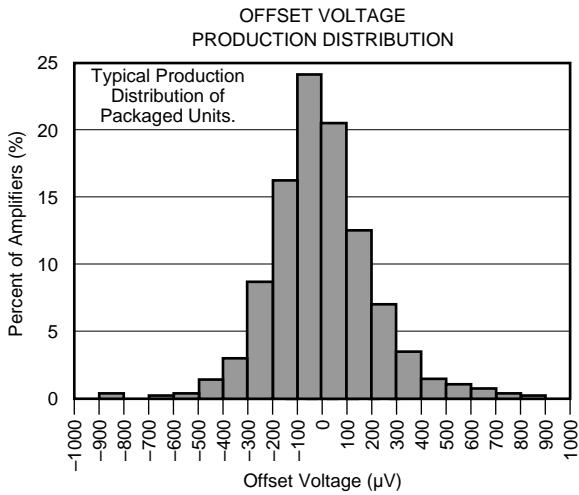
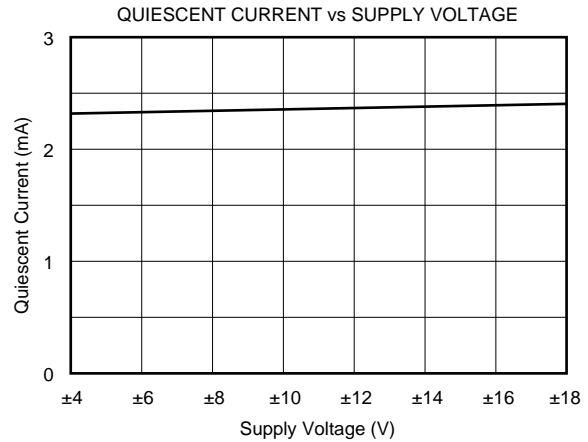
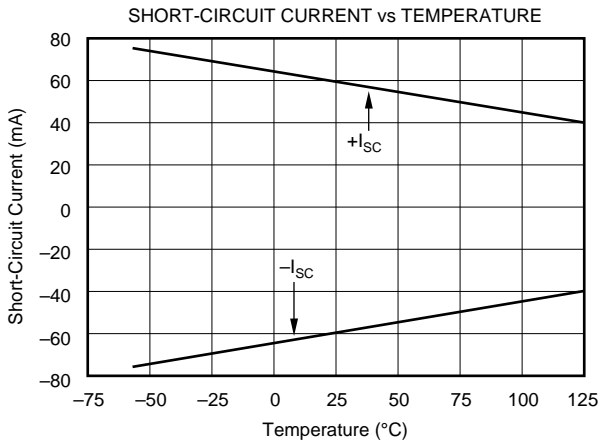
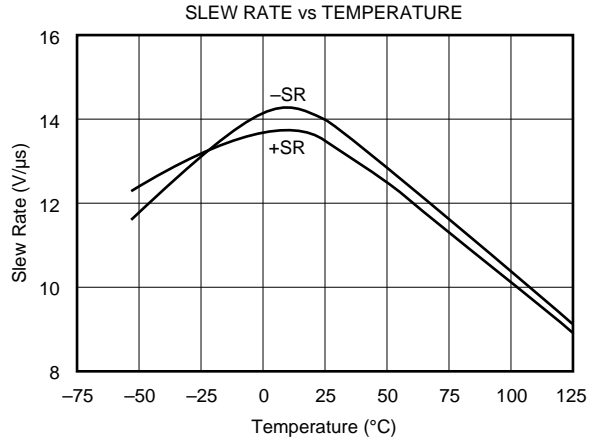
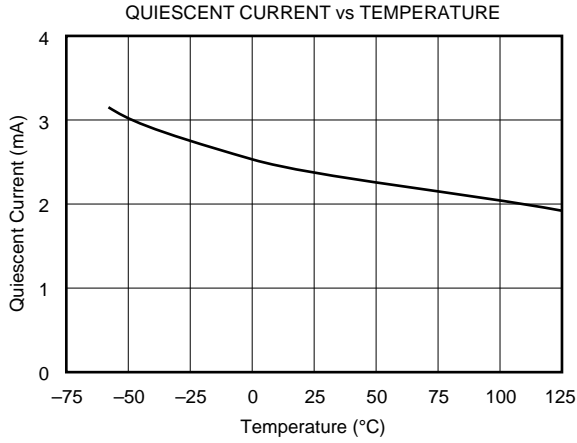

TYPICAL PERFORMANCE CURVES (CONT)

At $T_A = +25^\circ\text{C}$, $V_S = \pm 18\text{V}$, unless otherwise noted.

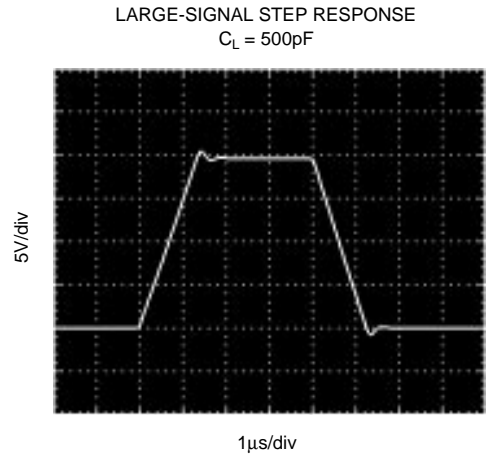
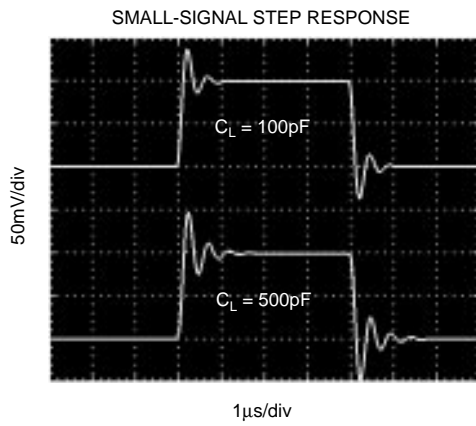
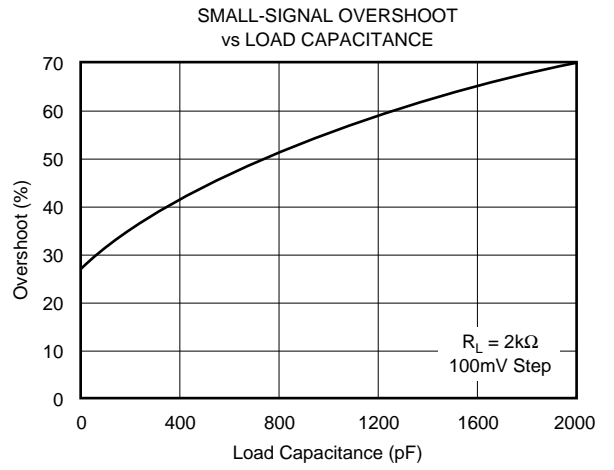
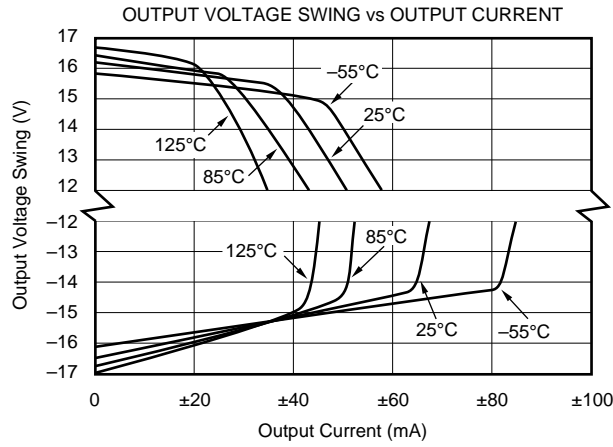

APPLICATIONS INFORMATION

Figure 1 shows the basic connections required for operation of the INA134. Decoupling capacitors are strongly recommended in applications with noisy or high impedance power supplies. The capacitors should be placed close to the device pins as shown in Figure 1. All circuitry is completely independent in the dual version assuring lowest crosstalk and normal behavior when one amplifier is overdriven or short-circuited.

As shown in Figure 1, the differential input signal is connected to pins 2 and 3. The source impedances connected to the inputs must be nearly equal to assure good common-mode rejection. A 10Ω mismatch in source impedance will degrade the common-mode rejection of a typical device to approximately 74dB. If the source has a known impedance mismatch, an additional resistor in series with the opposite input can be used to preserve good common-mode rejection.

Do not interchange pins 1 and 3 or pins 2 and 5, even though nominal resistor values are equal. These resistors are laser trimmed for precise resistor ratios to achieve accurate gain and highest CMR. Interchanging these pins would not provide specified performance.

AUDIO PERFORMANCE

The INA134 and INA2134 were designed for enhanced ac performance. Very low distortion, low noise, and wide bandwidth provide superior performance in high quality audio applications. Laser-trimmed matched resistors provide optimum common-mode rejection (typically 90dB), especially when compared to circuits implemented with an op amp and discrete precision resistors. In addition, high slew rate (14V/μs) and fast settling time (3μs to 0.01%) ensure good dynamic performance.

The INA134 and INA2134 have excellent distortion characteristics. THD+Noise is below 0.002% throughout the audio frequency range. Up to approximately 10kHz distortion is below the measurement limit of commonly used test equipment. Furthermore, distortion remains relatively flat over its wide output voltage swing range (approximately 1.7V from either supply).

OFFSET VOLTAGE TRIM

The INA134 and INA2134 are laser trimmed for low offset voltage and drift. Most applications require no external offset adjustment. Figure 2 shows an optional circuit for trimming the output offset voltage. The output is referred to the output reference terminal (pin 1), which is normally grounded. A voltage applied to the Ref terminal will be summed with the output signal. This can be used to null offset voltage as shown in Figure 2. The source impedance of a signal applied to the Ref terminal should be less than 10Ω to maintain good common-mode rejection.

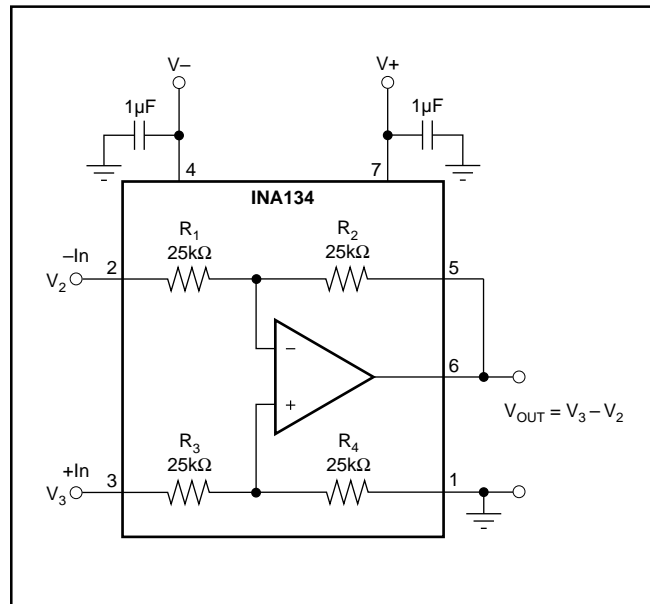

FIGURE 1. Precision Difference Amplifier (Basic Power Supply and Signal Connections).

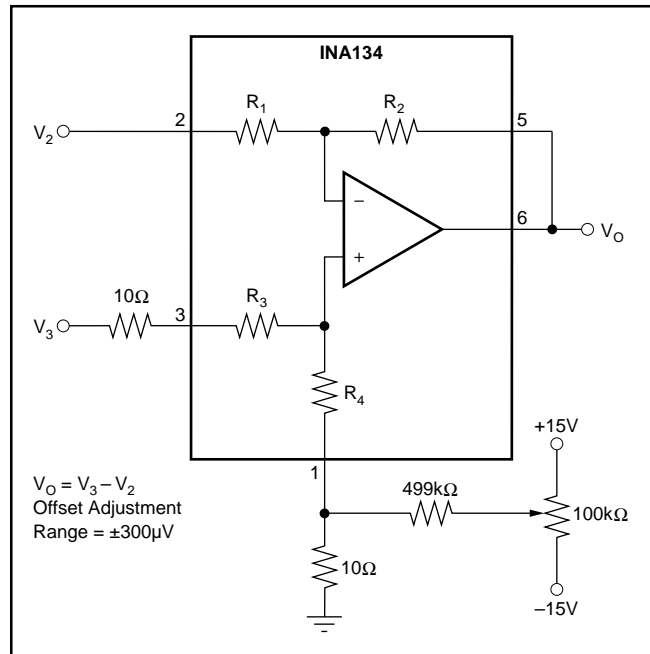

FIGURE 2. Offset Adjustment.

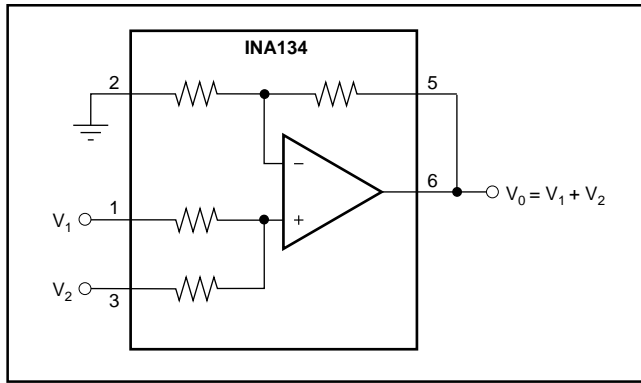

FIGURE 3. Precision Summing Amplifier.

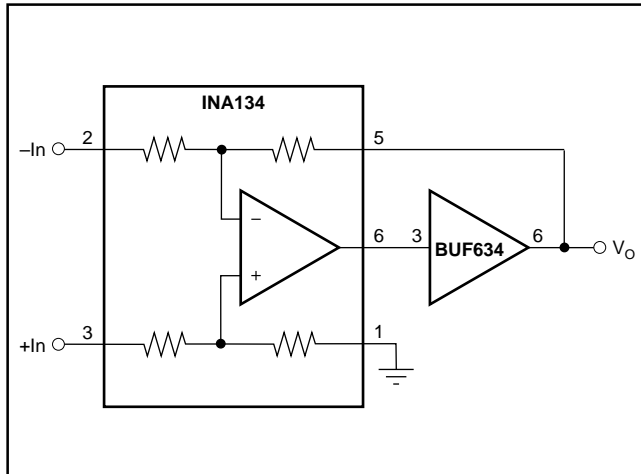

FIGURE 4. Boosting Output Current.

The difference amplifier is a highly versatile building block that is useful in a wide variety of applications. See the INA105 data sheet for additional applications ideas, including:

- Current Receiver with Compliance to Rails
- Precision Unity-Gain Inverting Amplifier
- $\pm 10\text{V}$ Precision Voltage Reference
- $\pm 5\text{V}$ Precision Voltage Reference
- Precision Unity-Gain Buffer
- Precision Average Value Amplifier
- Precision $G = 2$ Amplifier
- Precision Summing Amplifier
- Precision $G = 1/2$ Amplifier
- Precision Bipolar Offsetting
- Precision Summing Amplifier with Gain
- Instrumentation Amplifier Guard Drive Generator

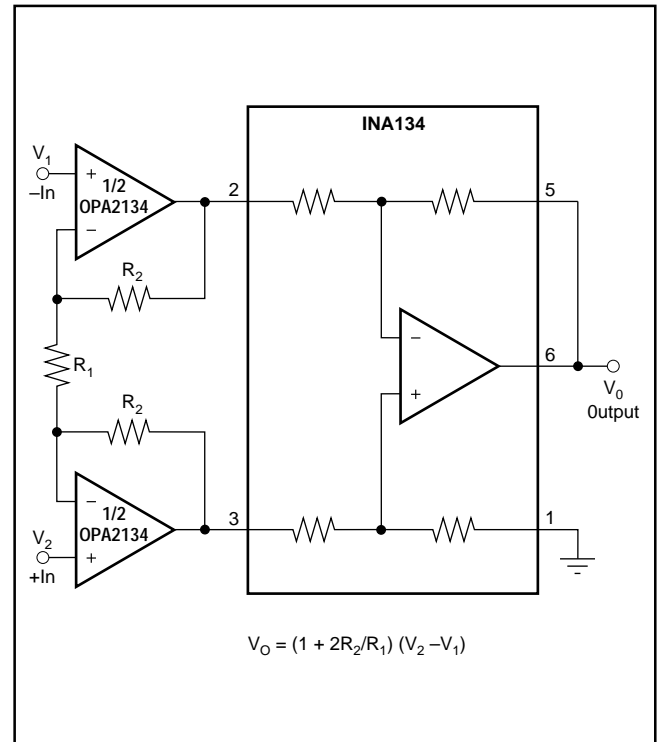

FIGURE 5. High Input Impedance Instrumentation Amplifier.

$$V_O = (1 + 2R_2/R_1)(V_2 - V_1)$$

- Precision Summing Instrumentation Amplifier
- Precision Absolute Value Buffer
- Precision Voltage-to-Current Converter with Differential Inputs
- Differential Input Voltage-to-Current Converter for Low I_{OUT}
- Isolating Current Source
- Differential Output Difference Amplifier
- Isolating Current Source with Buffering Amplifier for Greater Accuracy
- Window Comparator with Window Span and Window Center Inputs
- Precision Voltage-Controlled Current Source with Buffered Differential Inputs and Gain
- Digitally Controlled Gain of ± 1 Amplifier

PACKAGING INFORMATION

Orderable Device	Status ⁽¹⁾	Package Type	Package Drawing	Pins	Package Qty	Eco Plan ⁽²⁾	Lead/ Ball Finish	MSL Peak Temp ⁽³⁾	Samples (Requires Login)
INA134PA	ACTIVE	PDIP	P	8	50	Green (RoHS & no Sb/Br)	CU NIPDAU	N / A for Pkg Type	Add to cart
INA134PAG4	ACTIVE	PDIP	P	8	50	Green (RoHS & no Sb/Br)	CU NIPDAU	N / A for Pkg Type	Add to cart
INA134UA	ACTIVE	SOIC	D	8	75	Green (RoHS & no Sb/Br)	CU NIPDAU	Level-3-260C-168 HR	Add to cart
INA134UA/2K5	ACTIVE	SOIC	D	8	2500	Green (RoHS & no Sb/Br)	CU NIPDAU	Level-3-260C-168 HR	Add to cart
INA134UA/2K5E4	ACTIVE	SOIC	D	8	2500	Green (RoHS & no Sb/Br)	CU NIPDAU	Level-3-260C-168 HR	Add to cart
INA134UAE4	ACTIVE	SOIC	D	8	75	Green (RoHS & no Sb/Br)	CU NIPDAU	Level-3-260C-168 HR	Add to cart
INA134UAG4	ACTIVE	SOIC	D	8	75	Green (RoHS & no Sb/Br)	CU NIPDAU	Level-3-260C-168 HR	Add to cart
INA2134PA	ACTIVE	PDIP	N	14	25	Green (RoHS & no Sb/Br)	CU NIPDAU	N / A for Pkg Type	Add to cart
INA2134PAG4	ACTIVE	PDIP	N	14	25	Green (RoHS & no Sb/Br)	CU NIPDAU	N / A for Pkg Type	Add to cart
INA2134UA	ACTIVE	SOIC	D	14	50	Green (RoHS & no Sb/Br)	CU NIPDAU	Level-3-260C-168 HR	Add to cart
INA2134UA/2K5	ACTIVE	SOIC	D	14	2500	Green (RoHS & no Sb/Br)	CU NIPDAU	Level-3-260C-168 HR	Add to cart
INA2134UA/2K5E4	ACTIVE	SOIC	D	14	2500	Green (RoHS & no Sb/Br)	CU NIPDAU	Level-3-260C-168 HR	Add to cart
INA2134UA/2K5G4	ACTIVE	SOIC	D	14	2500	Green (RoHS & no Sb/Br)	CU NIPDAU	Level-3-260C-168 HR	Add to cart
INA2134UAE4	ACTIVE	SOIC	D	14	50	Green (RoHS & no Sb/Br)	CU NIPDAU	Level-3-260C-168 HR	Add to cart

⁽¹⁾ The marketing status values are defined as follows:

ACTIVE: Product device recommended for new designs.

LIFEBUY: TI has announced that the device will be discontinued, and a lifetime-buy period is in effect.

NRND: Not recommended for new designs. Device is in production to support existing customers, but TI does not recommend using this part in a new design.

PREVIEW: Device has been announced but is not in production. Samples may or may not be available.

OBSELETE: TI has discontinued the production of the device.

⁽²⁾ Eco Plan - The planned eco-friendly classification: Pb-Free (RoHS), Pb-Free (RoHS Exempt), or Green (RoHS & no Sb/Br) - please check <http://www.ti.com/productcontent> for the latest availability information and additional product content details.

TBD: The Pb-Free/Green conversion plan has not been defined.

Pb-Free (RoHS): TI's terms "Lead-Free" or "Pb-Free" mean semiconductor products that are compatible with the current RoHS requirements for all 6 substances, including the requirement that lead not exceed 0.1% by weight in homogeneous materials. Where designed to be soldered at high temperatures, TI Pb-Free products are suitable for use in specified lead-free processes.

Pb-Free (RoHS Exempt): This component has a RoHS exemption for either 1) lead-based flip-chip solder bumps used between the die and package, or 2) lead-based die adhesive used between the die and leadframe. The component is otherwise considered Pb-Free (RoHS compatible) as defined above.

Green (RoHS & no Sb/Br): TI defines "Green" to mean Pb-Free (RoHS compatible), and free of Bromine (Br) and Antimony (Sb) based flame retardants (Br or Sb do not exceed 0.1% by weight in homogeneous material)

⁽³⁾ MSL, Peak Temp. -- The Moisture Sensitivity Level rating according to the JEDEC industry standard classifications, and peak solder temperature.

Important Information and Disclaimer: The information provided on this page represents TI's knowledge and belief as of the date that it is provided. TI bases its knowledge and belief on information provided by third parties, and makes no representation or warranty as to the accuracy of such information. Efforts are underway to better integrate information from third parties. TI has taken and continues to take reasonable steps to provide representative and accurate information but may not have conducted destructive testing or chemical analysis on incoming materials and chemicals. TI and TI suppliers consider certain information to be proprietary, and thus CAS numbers and other limited information may not be available for release.

In no event shall TI's liability arising out of such information exceed the total purchase price of the TI part(s) at issue in this document sold by TI to Customer on an annual basis.

TAPE AND REEL INFORMATION
REEL DIMENSIONS

TAPE DIMENSIONS

A0	Dimension designed to accommodate the component width
B0	Dimension designed to accommodate the component length
K0	Dimension designed to accommodate the component thickness
W	Overall width of the carrier tape
P1	Pitch between successive cavity centers

TAPE AND REEL INFORMATION

*All dimensions are nominal

Device	Package Type	Package Drawing	Pins	SPQ	Reel Diameter (mm)	Reel Width W1 (mm)	A0 (mm)	B0 (mm)	K0 (mm)	P1 (mm)	W (mm)	Pin1 Quadrant
INA134UA/2K5	SOIC	D	8	2500	330.0	12.4	6.4	5.2	2.1	8.0	12.0	Q1
INA2134UA/2K5	SOIC	D	14	2500	330.0	16.4	6.5	9.0	2.1	8.0	16.0	Q1

TAPE AND REEL BOX DIMENSIONS

*All dimensions are nominal

Device	Package Type	Package Drawing	Pins	SPQ	Length (mm)	Width (mm)	Height (mm)
INA134UA/2K5	SOIC	D	8	2500	367.0	367.0	35.0
INA2134UA/2K5	SOIC	D	14	2500	367.0	367.0	38.0

P (R-PDIP-T8)

PLASTIC DUAL-IN-LINE PACKAGE

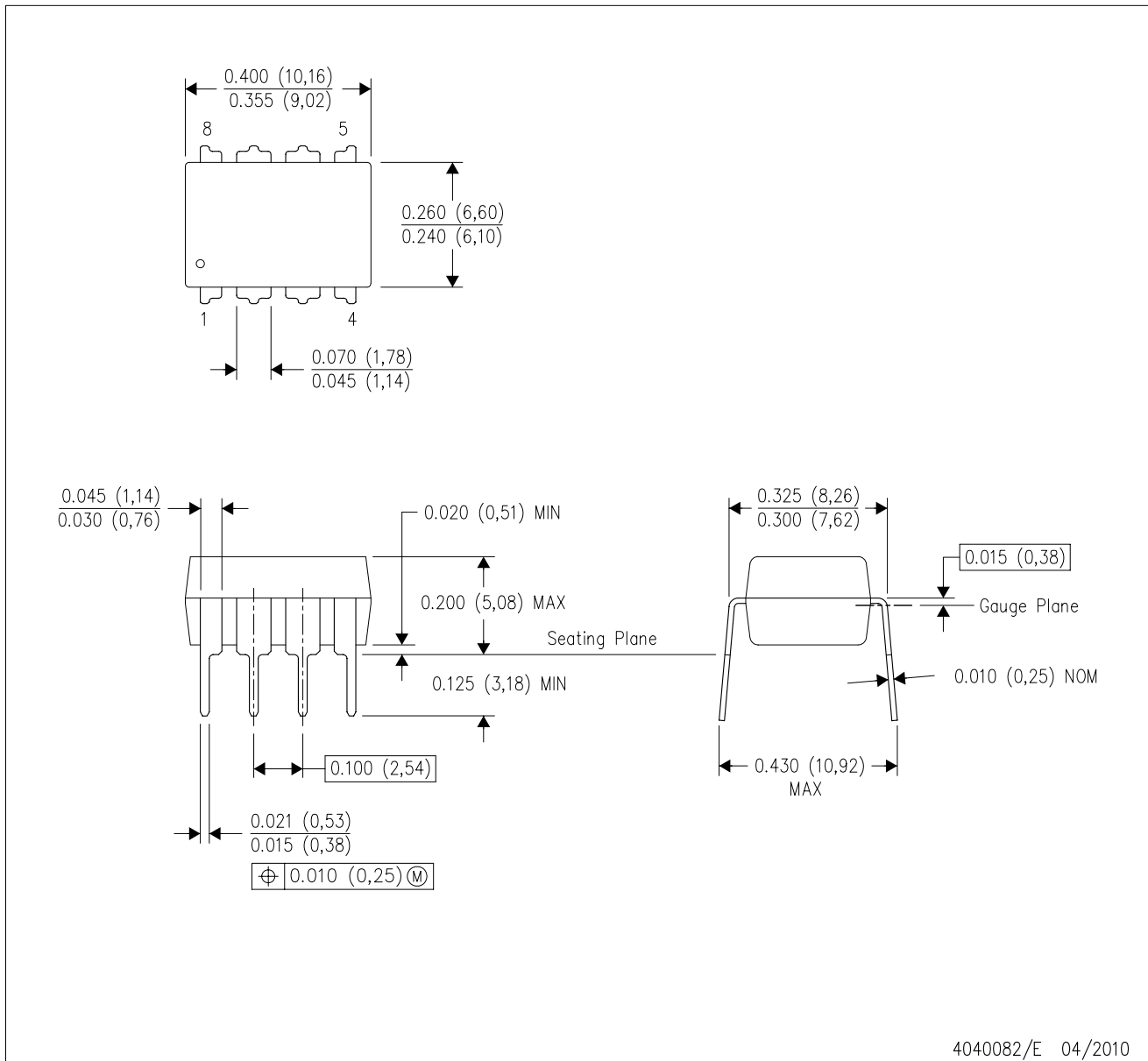

- NOTES:
- A. All linear dimensions are in inches (millimeters).
 - B. This drawing is subject to change without notice.
 - C. Falls within JEDEC MS-001 variation BA.

D (R-PDSO-G14)

PLASTIC SMALL OUTLINE



NOTES: A. All linear dimensions are in inches (millimeters).
 B. This drawing is subject to change without notice.
 C. Body length does not include mold flash, protrusions, or gate burrs. Mold flash, protrusions, or gate burrs shall not exceed 0.006 (0,15) each side.
 D. Body width does not include interlead flash. Interlead flash shall not exceed 0.017 (0,43) each side.
 E. Reference JEDEC MS-012 variation AB.

D (R-PDSO-G14)

PLASTIC SMALL OUTLINE



- NOTES:
- A. All linear dimensions are in millimeters.
 - B. This drawing is subject to change without notice.
 - C. Publication IPC-7351 is recommended for alternate designs.
 - D. Laser cutting apertures with trapezoidal walls and also rounding corners will offer better paste release. Customers should contact their board assembly site for stencil design recommendations. Refer to IPC-7525 for other stencil recommendations.
 - E. Customers should contact their board fabrication site for solder mask tolerances between and around signal pads.

D (R-PDSO-G8)

PLASTIC SMALL OUTLINE

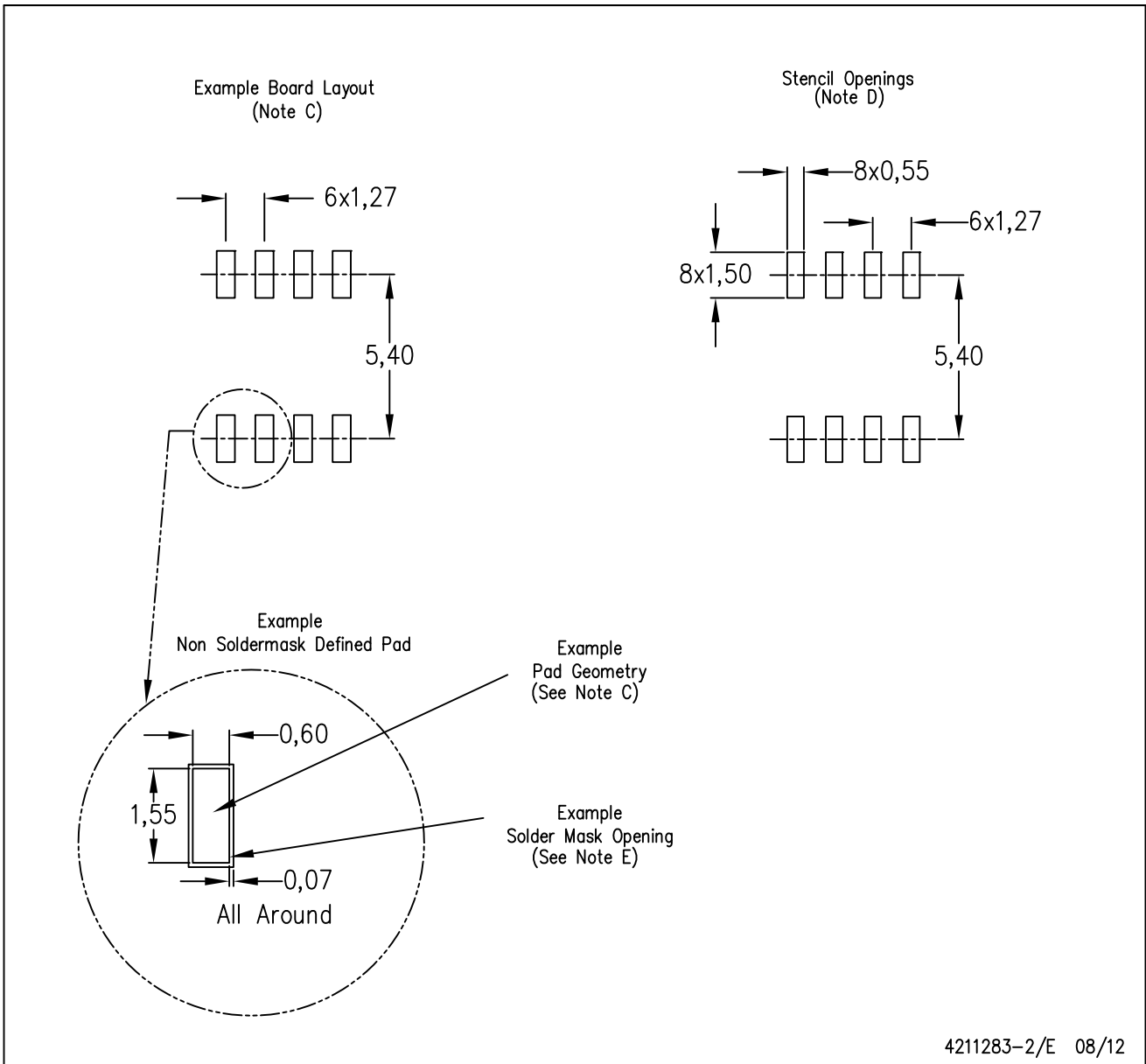

4211283-2/E 08/12

- NOTES:
- A. All linear dimensions are in millimeters.
 - B. This drawing is subject to change without notice.
 - C. Publication IPC-7351 is recommended for alternate designs.
 - D. Laser cutting apertures with trapezoidal walls and also rounding corners will offer better paste release. Customers should contact their board assembly site for stencil design recommendations. Refer to IPC-7525 for other stencil recommendations.
 - E. Customers should contact their board fabrication site for solder mask tolerances between and around signal pads.

IMPORTANT NOTICE

Texas Instruments Incorporated and its subsidiaries (TI) reserve the right to make corrections, enhancements, improvements and other changes to its semiconductor products and services per JESD46C and to discontinue any product or service per JESD48B. Buyers should obtain the latest relevant information before placing orders and should verify that such information is current and complete. All semiconductor products (also referred to herein as "components") are sold subject to TI's terms and conditions of sale supplied at the time of order acknowledgment.

TI warrants performance of its components to the specifications applicable at the time of sale, in accordance with the warranty in TI's terms and conditions of sale of semiconductor products. Testing and other quality control techniques are used to the extent TI deems necessary to support this warranty. Except where mandated by applicable law, testing of all parameters of each component is not necessarily performed.

TI assumes no liability for applications assistance or the design of Buyers' products. Buyers are responsible for their products and applications using TI components. To minimize the risks associated with Buyers' products and applications, Buyers should provide adequate design and operating safeguards.

TI does not warrant or represent that any license, either express or implied, is granted under any patent right, copyright, mask work right, or other intellectual property right relating to any combination, machine, or process in which TI components or services are used. Information published by TI regarding third-party products or services does not constitute a license to use such products or services or a warranty or endorsement thereof. Use of such information may require a license from a third party under the patents or other intellectual property of the third party, or a license from TI under the patents or other intellectual property of TI.

Reproduction of significant portions of TI information in TI data books or data sheets is permissible only if reproduction is without alteration and is accompanied by all associated warranties, conditions, limitations, and notices. TI is not responsible or liable for such altered documentation. Information of third parties may be subject to additional restrictions.

Resale of TI components or services with statements different from or beyond the parameters stated by TI for that component or service voids all express and any implied warranties for the associated TI component or service and is an unfair and deceptive business practice. TI is not responsible or liable for any such statements.

Buyer acknowledges and agrees that it is solely responsible for compliance with all legal, regulatory and safety-related requirements concerning its products, and any use of TI components in its applications, notwithstanding any applications-related information or support that may be provided by TI. Buyer represents and agrees that it has all the necessary expertise to create and implement safeguards which anticipate dangerous consequences of failures, monitor failures and their consequences, lessen the likelihood of failures that might cause harm and take appropriate remedial actions. Buyer will fully indemnify TI and its representatives against any damages arising out of the use of any TI components in safety-critical applications.

In some cases, TI components may be promoted specifically to facilitate safety-related applications. With such components, TI's goal is to help enable customers to design and create their own end-product solutions that meet applicable functional safety standards and requirements. Nonetheless, such components are subject to these terms.

No TI components are authorized for use in FDA Class III (or similar life-critical medical equipment) unless authorized officers of the parties have executed a special agreement specifically governing such use.

Only those TI components which TI has specifically designated as military grade or "enhanced plastic" are designed and intended for use in military/aerospace applications or environments. Buyer acknowledges and agrees that any military or aerospace use of TI components which have **not** been so designated is solely at the Buyer's risk, and that Buyer is solely responsible for compliance with all legal and regulatory requirements in connection with such use.

TI has specifically designated certain components which meet ISO/TS16949 requirements, mainly for automotive use. Components which have not been so designated are neither designed nor intended for automotive use; and TI will not be responsible for any failure of such components to meet such requirements.

Products

Audio	www.ti.com/audio
Amplifiers	amplifier.ti.com
Data Converters	dataconverter.ti.com
DLP® Products	www.dlp.com
DSP	dsp.ti.com
Clocks and Timers	www.ti.com/clocks
Interface	interface.ti.com
Logic	logic.ti.com
Power Mgmt	power.ti.com
Microcontrollers	microcontroller.ti.com
RFID	www.ti-rfid.com
OMAP Mobile Processors	www.ti.com/omap
Wireless Connectivity	www.ti.com/wirelessconnectivity

Applications

Automotive and Transportation	www.ti.com/automotive
Communications and Telecom	www.ti.com/communications
Computers and Peripherals	www.ti.com/computers
Consumer Electronics	www.ti.com/consumer-apps
Energy and Lighting	www.ti.com/energy
Industrial	www.ti.com/industrial
Medical	www.ti.com/medical
Security	www.ti.com/security
Space, Avionics and Defense	www.ti.com/space-avionics-defense
Video and Imaging	www.ti.com/video

TI E2E Community e2e.ti.com