

LM3552 White LED Flash Driver Evaluation Board

National Semiconductor
Application Note 1495
September 2006

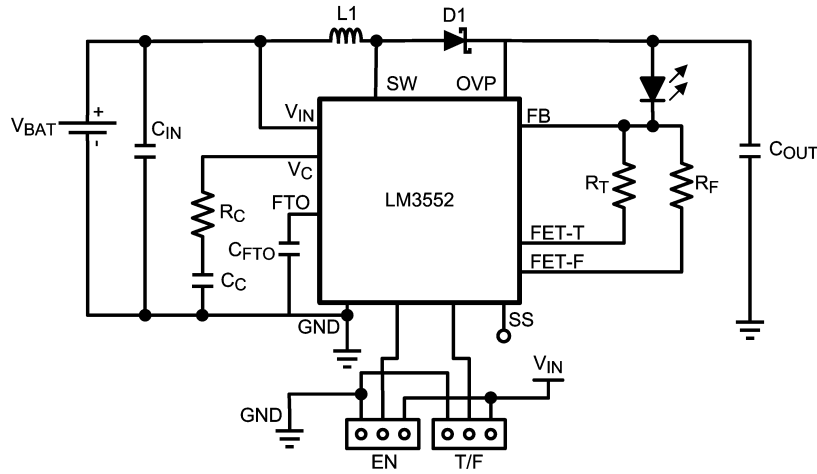

Schematic



20196901

Bill of Materials

Component Symbol	Value	Package	Dimensions (mm)	Temperature Characteristic	Manufacturer	Part #
LM3552	--	SDA14B LLP14	4.0 x 4.0 x 0.8	--	National	LM3552SDX
LED	Flash LED	--	2.04 x 1.64 x 0.7	--	Lumileds	LXCL-PWF1
L1	4.7μH	--	4.5 x 4.7 x 1.4	--	TDK	VLF5014AT-4R7M1R1
C _{IN}	10μF, 10V	0805	2.0 x 1.25 x 1.45	X5R	TDK	C2012X5R1A106K
C _{OUT}	10μF, 16V	1206	3.2 x 1.6 x 1.9	X7R	TDK	C3216X7R1C106M
C _C	4.7nF	0805	2.0 x 1.25 x 1.45	C0G	TDK	C2012C0G1H472J
C _{F_{TO}}	1μF, 10V	0603	1.6 x 0.8 x 0.9	X5R	TDK	C1608X5R1A105
C _{SS}	0.1μF	0603	1.6 x 0.8 x 0.9	X7R	TDK	C1608X7R1E104
D1	1A, 20V	SOD-123	3.6 x 1.65 x 0.95	--	ON Semiconductor	MBR120VLSFT1
R _C	10kΩ	0805	2.0 x 1.25 x 0.45	--	Vishay Dale	CRCW08051002F
R _T	5.6Ω, 1/2W	2010	5.0 x 2.5 x 0.6	--	Panasonic	ERJ-12ZYJ5R6U
R _F	2.2Ω, 1/2W	2010	5.0 x 2.5 x 0.6	--	Panasonic	ERJ-12ZYJ2R2U

LM3552 White LED Flash Driver Evaluation Board Layout

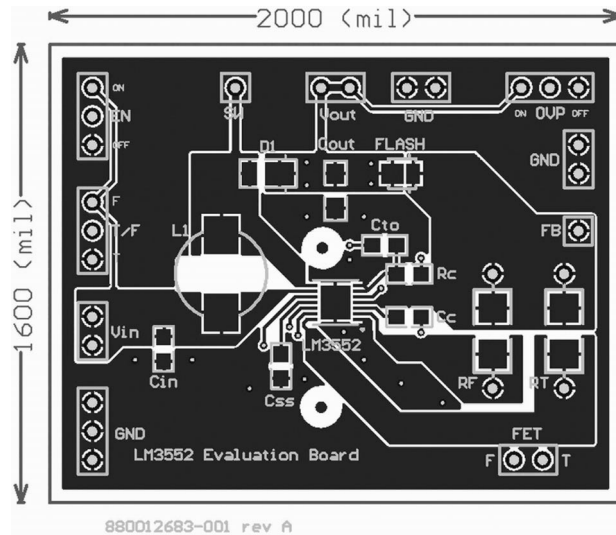

FIGURE 1. Top Layer

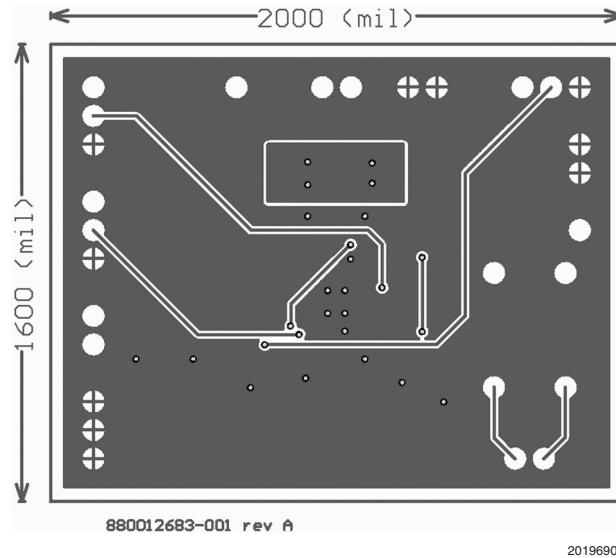

FIGURE 2. Bottom Layer (unmirrored)

Board Operation

BASIC CONNECTIONS

To operate the LM3552 White LED Flash Driver Evaluation Board, connect a supply voltage (2.7V-5.5V) between board connectors VIN and GND.

Default Jumper Connections:

- EN: Connects the "OFF" post to the middle post of the EN header strip. This connects GND to the EN pin of the LM3552, disabling the part.
- T/F: Connects the "T" post to the middle post of the T/F header strip. This connects GND to the T/F pin of the LM3552, placing the part into the 200mA torch mode when the part is enabled

When these connections are all made correctly, the Flash LED will be OFF. Setting the EN jumper to the ON position

will enable the part and turn on the flash LED. In torch mode, the LED current will be set to approximately 200mA. Placing the the T/F jumper across the '+' pin and the T/F pin enables flash mode. The total current delivered to the LED is approximately 700mA. If this jumper is left in flash mode, the internal time-out circuit will disable the switcher after approximately 1 second.

The EN pin has an internal pull-down resistor placing the part in shutdown by default. The T/F pin does not have a pull-up or pull-down resistor. If left unconnected, it is unknown as to whether the LM3552 is in torch or flash mode.

For more information regarding the operation of the LM3551/2, please refer to the LM3551/2 datasheet.

National does not assume any responsibility for use of any circuitry described, no circuit patent licenses are implied and National reserves the right at any time without notice to change said circuitry and specifications.

For the most current product information visit us at www.national.com.

LIFE SUPPORT POLICY

NATIONAL'S PRODUCTS ARE NOT AUTHORIZED FOR USE AS CRITICAL COMPONENTS IN LIFE SUPPORT DEVICES OR SYSTEMS WITHOUT THE EXPRESS WRITTEN APPROVAL OF THE PRESIDENT AND GENERAL COUNSEL OF NATIONAL SEMICONDUCTOR CORPORATION. As used herein:

1. Life support devices or systems are devices or systems which, (a) are intended for surgical implant into the body, or (b) support or sustain life, and whose failure to perform when properly used in accordance with instructions for use provided in the labeling, can be reasonably expected to result in a significant injury to the user.
2. A critical component is any component of a life support device or system whose failure to perform can be reasonably expected to cause the failure of the life support device or system, or to affect its safety or effectiveness.

BANNED SUBSTANCE COMPLIANCE

National Semiconductor follows the provisions of the Product Stewardship Guide for Customers (CSP-9-111C2) and Banned Substances and Materials of Interest Specification (CSP-9-111S2) for regulatory environmental compliance. Details may be found at: www.national.com/quality/green.

Lead free products are RoHS compliant.



National Semiconductor
Americas Customer
Support Center
Email: new.feedback@nsc.com
Tel: 1-800-272-9959

www.national.com

National Semiconductor
Europe Customer Support Center
Fax: +49 (0) 180-530 85 86
Email: europe.support@nsc.com
Deutsch Tel: +49 (0) 69 9508 6208
English Tel: +44 (0) 870 24 0 2171
Français Tel: +33 (0) 1 41 91 8790

National Semiconductor
Asia Pacific Customer
Support Center
Email: ap.support@nsc.com

National Semiconductor
Japan Customer Support Center
Fax: 81-3-5639-7507
Email: jpn.feedback@nsc.com
Tel: 81-3-5639-7560