

## FEATURES

- 2.7-V and 5-V Performance
- Low Offset Voltage . . . 0.4 mV Typ, 3 mV Max
- Input Common-Mode Range . . . 200 mV Beyond the Rails
- Rail-to-Rail Swing Into 600  $\Omega$
- Gain Bandwidth . . . 5 MHz Typ
- Slew Rate . . . 5 V/ $\mu$ s Typ
- Turn-On Time From Shutdown . . . <10  $\mu$ s
- Shutdown Current . . . 0.2  $\mu$ A Typ
- Space-Saving Packages
  - SOT-23-5/6
  - SC-70

## APPLICATIONS

- Wireless Phones, Mobile Phones, PDAs
- GSM/TDMA/CDMA Power Amp Control
- AGC, RF Power Detectors
- Temperature Compensation
- Wireless LANs
- Bluetooth
- HomeRF

## DESCRIPTION/ORDERING INFORMATION

The LMV710, LMV711, and LMV715 are single BiCMOS operational amplifiers designed to meet the demands of low power, low cost, and small size required by battery-powered portable electronics. These devices have an input common-mode voltage range that exceeds the rails, rail-to-rail output, and high output-current drive. The devices offer a bandwidth of 5 MHz and a slew rate of 5 V/ $\mu$ s.

On the LMV711 and LMV715, a separate shutdown pin can be used to disable the device and reduce the supply current to 0.2  $\mu$ A typical. The device features a turn-on time of less than 10  $\mu$ s. It is an ideal solution for power-sensitive applications, such as cellular phones, pagers, palm computers, etc.

The LMV710I, LMV711I, and LMV715I are characterized for operation from  $-40^{\circ}\text{C}$  to  $85^{\circ}\text{C}$ .

## ORDERING INFORMATION

T <sub>A</sub>	PACKAGE <sup>(1)</sup>		ORDERABLE PART NUMBER	TOP-SIDE MARKING <sup>(2)</sup>
$-40^{\circ}\text{C}$ to $85^{\circ}\text{C}$	SOT-23-5 – DBV	Reel of 3000	LMV710IDBVR	RB4_
	SC-70 – DCK	Reel of 3000	LMV710IDCKR	RE_
	SOT-23-6 – DBV	Reel of 3000	LMV711IDBVR	RB5_
	SC-70 – DCK	Reel of 3000	LMV711IDCKR	RF_
	SOT-23-6 – DBV	Reel of 3000	LMV715IDBVR	4B9_
	SC-70 – DCK	Reel of 3000	LMV715IDCKR	RL_

(1) Package drawings, standard packing quantities, thermal data, symbolization, and PCB design guidelines are available at [www.ti.com/sc/package](http://www.ti.com/sc/package).

(2) DBV/DCK: The actual top-side marking has one additional character that designates the assembly/test site.

LMV710  
DBV (SOT-23-5) OR DCK (SC-70) PACKAGE  
(TOP VIEW)

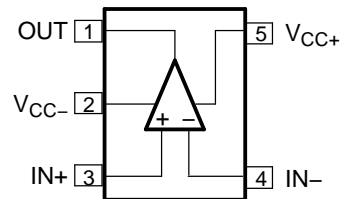

LMV711/LMV715  
DBV (SOT-23-6) OR DCK (SC-70) PACKAGE  
(TOP VIEW)

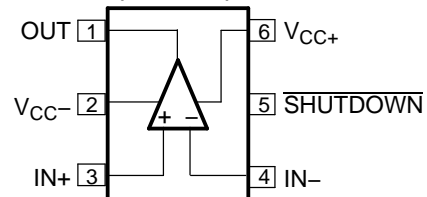

Please be aware that an important notice concerning availability, standard warranty, and use in critical applications of Texas Instruments semiconductor products and disclaimers thereto appears at the end of this data sheet.

**LMV710, LMV711, LMV715**  
**SINGLE LOW-POWER RRIO OPERATIONAL AMPLIFIERS**  
**WITH HIGH OUTPUT CURRENT DRIVE AND SHUTDOWN**

SLOS463A—APRIL 2005—REVISED JULY 2005

**SYMBOL (EACH AMPLIFIER)**

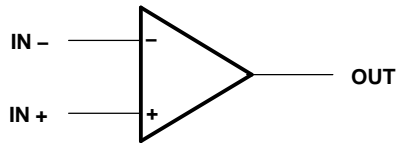

**SIMPLIFIED SCHEMATIC**

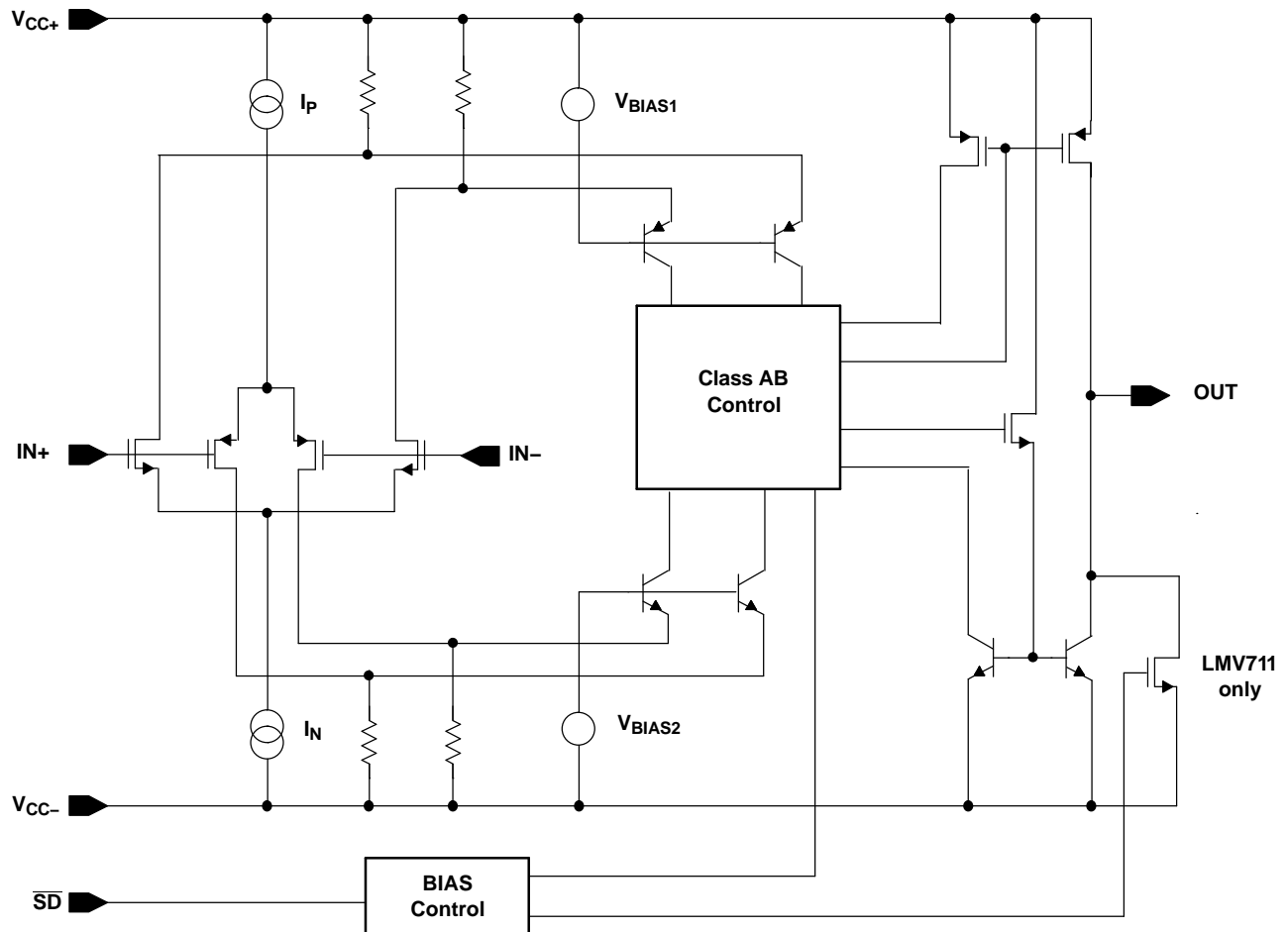

## Absolute Maximum Ratings<sup>(1)</sup>

over operating free-air temperature range (unless otherwise noted)

		MIN	MAX	UNIT	
$V_{CC+} - V_{CC-}$	Supply voltage <sup>(2)</sup>		6	V	
$V_{ID}$	Differential input voltage <sup>(3)</sup>		±Supply voltage	V	
$V_I$	Input voltage (either input)	$V_{CC-} - 0.4$	$V_{CC+} + 0.4$	V	
$V_O$	Output voltage	$V_{CC-} - 0.4$	$V_{CC+} + 0.4$	V	
$I_I$	Input current <sup>(4)</sup>		±10	mA	
$\theta_{JA}$	Package thermal impedance <sup>(5)(6)</sup>	DBV package	5 pin	206	°C/W
			6 pin	165	
		DCK package	5 pin	252	
			6 pin	259	
$T_J$	Operating virtual junction temperature		150	°C	
$T_{stg}$	Storage temperature range	-65	150	°C	

- (1) Stresses beyond those listed under “absolute maximum ratings” may cause permanent damage to the device. These are stress ratings only, and functional operation of the device at these or any other conditions beyond those indicated under “recommended operating conditions” is not implied. Exposure to absolute-maximum-rated conditions for extended periods may affect device reliability.
- (2) All voltage values (except differential voltages and  $V_{CC}$  specified for the measurement of  $I_{OS}$ ) are with respect to the network GND.
- (3) Differential voltages are at IN+ with respect to IN-.
- (4) Excessive input current will flow if a differential input voltage in excess of approximately 0.6 V is applied between the inputs unless some limiting resistance is used.
- (5) Maximum power dissipation is a function of  $T_J(\text{max})$ ,  $\theta_{JA}$ , and  $T_A$ . The maximum allowable power dissipation at any allowable ambient temperature is  $P_D = (T_J(\text{max}) - T_A)/\theta_{JA}$ . Operating at the absolute maximum  $T_J$  of 150°C can affect reliability.
- (6) The package thermal impedance is calculated in accordance with JEDEC 51-7.

## Recommended Operating Conditions

		MIN	MAX	UNIT
$V_{CC+} - V_{CC-}$	Supply voltage	2.7	5	V
$T_A$	Operating free-air temperature	-40	85	°C

## ESD Protection

	TYP	UNIT
Human-Body Model	TBD	V
Machine Model	TBD	V

# LMV710, LMV711, LMV715

## SINGLE LOW-POWER RRIO OPERATIONAL AMPLIFIERS

### WITH HIGH OUTPUT CURRENT DRIVE AND SHUTDOWN

SLOS463A–APRIL 2005–REVISED JULY 2005

### Electrical Characteristics

 $V_{CC+} = 2.7\text{ V}$ ,  $V_{CC-} = \text{GND}$ ,  $V_{IC} = 1.35\text{ V}$ , and  $R_L > 1\text{ M}\Omega$  (unless otherwise noted)

PARAMETER	TEST CONDITIONS	$T_A$	MIN	TYP	MAX	UNIT		
$V_{IO}$	Input offset voltage	$V_{IC} = 0.85\text{ V}$ and $1.85\text{ V}$	25°C	0.4	3	mV		
			–40°C to 85°C		3.2			
$I_{IB}$	Input bias current		25°C	4		pA		
CMRR	Common-mode rejection ratio	$0 \leq V_{IC} \leq 2.7\text{ V}$	25°C	50	75	dB		
			–40°C to 85°C	45				
$k_{SVR}$	Supply-voltage rejection ratio	$2.7\text{ V} \leq V_{CC+} \leq 5\text{ V}$ , $V_{IC} = 0.85\text{ V}$	25°C	70	110	dB		
			–40°C to 85°C	68				
			25°C	70	95			
			–40°C to 85°C	68				
$V_{ICR}$	Common-mode input voltage range	CMRR $\geq 50\text{ dB}$	25°C	–0.2 to 2.9	–0.3 to 3	V		
$I_{OS}$	Output short circuit current <sup>(1)</sup>	Sourcing $V_O = 0$	25°C	15	28	mA		
			–40°C to 85°C	12				
			25°C	25	40			
			–40°C to 85°C	22				
$V_O$	Output voltage	$R_L = 10\text{ k}\Omega$ to $1.35\text{ V}$	$V_{OH}$	25°C	2.62	2.68	V	
				–40°C to 85°C	2.6			
			$V_{OL}$	25°C		0.01		0.12
				–40°C to 85°C				0.15
		$R_L = 600\ \Omega$ to $1.35\text{ V}$	$V_{OH}$	25°C	2.52	2.55		
				–40°C to 85°C	2.5			
			$V_{OL}$	25°C		0.05		0.23
				–40°C to 85°C				0.3
$V_{O(SD)}$	Output voltage level in shutdown mode	LMV711 only	25°C	50	200	mV		
$I_{O(SD)}$	Output leakage current in shutdown mode	LMV715 only	25°C	1		pA		
$C_{O(SD)}$	Output capacitance in shutdown mode	LMV715 only	25°C	32		pF		
$I_{CC}$	Supply current	ON mode	25°C	1.22	1.7	mA		
		–40°C to 85°C		1.9				
$A_V$	Large-signal voltage gain	Sourcing $R_L = 10\text{ k}\Omega$ , $V_O = 1.35\text{ V}$ to $2.3\text{ V}$	25°C	80	115	dB		
			–40°C to 85°C	76				
		Sinking $R_L = 10\text{ k}\Omega$ , $V_O = 0.4\text{ V}$ to $1.35\text{ V}$	25°C	80	113			
			–40°C to 85°C	76				
		Sourcing $R_L = 600\ \Omega$ , $V_O = 1.35\text{ V}$ to $2.2\text{ V}$	25°C	80	110			
			–40°C to 85°C	76				
		Sinking $R_L = 600\ \Omega$ , $V_O = 0.5\text{ V}$ to $1.35\text{ V}$	25°C	80	100			
			–40°C to 85°C	76				
SR <sup>(2)</sup>	Slew rate		25°C	5		V/ $\mu\text{s}$		
GBWP	Gain bandwidth product		25°C	5		MHz		
$\Phi_m$	Phase margin		25°C	60		deg		
$T_{(on)}$	Amplifier turn-on time		25°C	<10		$\mu\text{s}$		

(1) Shorting the output to either supply rails will adversely affect reliability.

(2) Number specified is the slower of the positive and negative slew rates.

**Electrical Characteristics (continued)**
 $V_{CC+} = 2.7\text{ V}$ ,  $V_{CC-} = \text{GND}$ ,  $V_{IC} = 1.35\text{ V}$ , and  $R_L > 1\text{ M}\Omega$  (unless otherwise noted)

PARAMETER	TEST CONDITIONS	$T_A$	MIN	TYP	MAX	UNIT
$\overline{\text{SHDN}}$ Shutdown pin voltage range	$V_{(\text{ON})}$	25°C	2.4 to 2.7	1.5 to 2.7		V
	$V_{(\text{OFF})}$			0 to 1 to 0.8	0	
$V_n$ Input referred voltage noise	$f = 1\text{ kHz}$	25°C		20		$\text{nV}/\sqrt{\text{Hz}}$

**Electrical Characteristics**
 $V_{CC+} = 3.2\text{ V}$ ,  $V_{CC-} = \text{GND}$ , and  $V_{IC} = 1.6\text{ V}$  (unless otherwise noted)

PARAMETER	TEST CONDITIONS	$T_A$	MIN	TYP	MAX	UNIT	
$V_O$ Output voltage	$I_O = 6.5\text{ mA}$	$V_{\text{OH}}$	25°C	2.95	3	V	
			–40°C to 85°C	2.92			
		$V_{\text{OL}}$	25°C		0.01		0.18
			–40°C to 85°C				0.25

# LMV710, LMV711, LMV715

## SINGLE LOW-POWER RRIO OPERATIONAL AMPLIFIERS WITH HIGH OUTPUT CURRENT DRIVE AND SHUTDOWN

SLOS463A–APRIL 2005–REVISED JULY 2005

### Electrical Characteristics

 $V_{CC+} = 5\text{ V}$ ,  $V_{CC-} = \text{GND}$ ,  $V_{IC} = 2.5\text{ V}$ , and  $R_L > 1\text{ M}\Omega$  (unless otherwise noted)

PARAMETER		TEST CONDITIONS	$T_A$	MIN	TYP	MAX	UNIT	
$V_{IO}$	Input offset voltage	$V_{IC} = 0.85\text{ V}$ and $1.85\text{ V}$	25°C		0.4	3	mV	
			–40°C to 85°C			3.2		
$I_{IB}$	Input bias current		25°C		4		pA	
CMRR	Common-mode rejection ratio	$0 \leq V_{IC} \leq 2.7\text{ V}$	25°C	50	75		dB	
			–40°C to 85°C	48				
$k_{SVR}$	Supply-voltage rejection ratio	$2.7\text{ V} \leq V_{CC+} \leq 5\text{ V}$ , $V_{IC} = 0.85\text{ V}$	25°C	70	110		dB	
			–40°C to 85°C	68				
			25°C	70	95			
			–40°C to 85°C	68				
$V_{ICR}$	Common-mode input voltage range	CMRR $\geq 50\text{ dB}$	25°C	–0.2 to 5.2	–0.3 to 5.3		V	
$I_{OS}$	Output short circuit current <sup>(1)</sup>	Sourcing $V_O = 0$	25°C	25	35		mA	
			–40°C to 85°C	21				
			25°C	25	40			
			–40°C to 85°C	21				
$V_O$	Output voltage	$R_L = 10\text{ k}\Omega$ to $1.35\text{ V}$	$V_{OH}$	25°C	4.92	4.98		V
				–40°C to 85°C	4.9			
			$V_{OL}$	25°C		0.01	0.12	
				–40°C to 85°C			0.15	
		$R_L = 600\ \Omega$ to $1.35\text{ V}$	$V_{OH}$	25°C	4.82	4.85		
				–40°C to 85°C	4.8			
			$V_{OL}$	25°C		0.05	0.23	
				–40°C to 85°C			0.3	
$V_{O(SD)}$	Output voltage level in shutdown mode	LMV711 only	25°C		50	200	mV	
$I_{O(SD)}$	Output leakage current in shutdown mode	LMV715 only	25°C		1		pA	
$C_{O(SD)}$	Output capacitance in shutdown mode	LMV715 only	25°C		32		pF	
$I_{CC}$	Supply current	ON mode	25°C		1.17	1.7	mA	
		–40°C to 85°C				1.9		
$A_V$	Large-signal voltage gain	Sourcing $R_L = 10\text{ k}\Omega$ , $V_O = 1.35\text{ V}$ to $2.3\text{ V}$	25°C	80	123		dB	
			–40°C to 85°C	76				
		Sinking $R_L = 10\text{ k}\Omega$ , $V_O = 0.4\text{ V}$ to $1.35\text{ V}$	25°C	80	120			
			–40°C to 85°C	76				
		Sourcing $R_L = 600\ \Omega$ , $V_O = 1.35\text{ V}$ to $2.2\text{ V}$	25°C	80	110			
			–40°C to 85°C	76				
		Sinking $R_L = 600\ \Omega$ , $V_O = 0.5\text{ V}$ to $1.35\text{ V}$	25°C	80	118			
			–40°C to 85°C	76				
SR <sup>(2)</sup>	Slew rate		25°C		5		V/ $\mu\text{s}$	
GBWP	Gain bandwidth product		25°C		5		MHz	
$\Phi_m$	Phase margin		25°C		60		deg	
$T_{(on)}$	Amplifier turn-on time		25°C		<10		$\mu\text{s}$	

(1) Shorting the output to either supply rails will adversely affect reliability.

(2) Number specified is the slower of the positive and negative slew rates.

**Electrical Characteristics (continued)**

$V_{CC+} = 5\text{ V}$ ,  $V_{CC-} = \text{GND}$ ,  $V_{IC} = 2.5\text{ V}$ , and  $R_L > 1\text{ M}\Omega$  (unless otherwise noted)

PARAMETER	TEST CONDITIONS	$T_A$	MIN	TYP	MAX	UNIT
$\overline{\text{SHDN}}$ Shutdown pin voltage range	$V_{(\text{ON})}$	25°C	2.4 to 5	2 to 5		V
	$V_{(\text{OFF})}$			0 to 1.5	0 to 0.8	
$V_n$ Input referred voltage noise	$f = 1\text{ kHz}$	25°C		20		$\text{nV}/\sqrt{\text{Hz}}$

## TYPICAL PERFORMANCE CHARACTERISTICS

### GRAPH PREVIEWS

- Figure 1. Supply Current vs Supply Voltage (ON Mode)
- Figure 2. LMV711/LMV715 Supply Current vs Supply Voltage (Shutdown Mode)
- Figure 3. Output Positive Swing vs Supply Voltage  $R_L = 600 \Omega$
- Figure 4. Output Negative Swing vs Supply Voltage  $R_L = 600 \Omega$
- Figure 5. Output Positive Swing vs Supply Voltage  $R_L = 10 \text{ k}\Omega$
- Figure 6. Output Negative Swing vs Supply Voltage  $R_L = 10 \text{ k}\Omega$
- Figure 7. Output Positive Swing vs Supply Voltage ( $I_{\text{SRC}} = 7 \text{ mA}$ )
- Figure 8. Output Negative Swing vs Supply Voltage ( $I_{\text{SINK}} = 7 \text{ mA}$ )
- Figure 9. Input Voltage Noise vs Frequency
- Figure 10. PSRR vs Frequency
- Figure 11. CMRR vs Frequency
- Figure 12. LMV711/LMV715 Turn-On Characteristics
- Figure 13. Sourcing Current vs Output Voltage
- Figure 14. Sinking Current vs Output Voltage
- Figure 15. THD+N vs Frequency ( $V_{\text{CC}} = 5 \text{ V}$ )
- Figure 16. THD+N vs Frequency ( $V_{\text{CC}} = 2.7 \text{ V}$ )
- Figure 17. THD+N vs  $V_{\text{OUT}}$  ( $V_{\text{CC}\pm} = \pm 2.5 \text{ V}$ )
- Figure 18. THD+N vs  $V_{\text{OUT}}$  ( $V_{\text{CC}\pm} = \pm 1.35 \text{ V}$ )
- Figure 19.  $C_{\text{CM}}$  vs  $V_{\text{CM}}$  ( $V_{\text{CC}} = 2.7 \text{ V}$ )
- Figure 20.  $C_{\text{CM}}$  vs  $V_{\text{CM}}$  ( $V_{\text{CC}} = 5 \text{ V}$ )
- Figure 21.  $C_{\text{DIFF}}$  vs  $V_{\text{CM}}$  ( $V_{\text{CC}} = 2.7 \text{ V}$ )
- Figure 22.  $C_{\text{DIFF}}$  vs  $V_{\text{CM}}$  ( $V_{\text{CC}} = 5 \text{ V}$ )
- Figure 23. Open-Loop Frequency Response ( $V_{\text{CC}\pm} = \pm 1.35 \text{ V}$ )
- Figure 24. Open-Loop Frequency Response ( $V_{\text{CC}\pm} = \pm 1.6 \text{ V}$ )
- Figure 25. Open-Loop Frequency Response ( $V_{\text{CC}\pm} = \pm 2.5 \text{ V}$ )
- Figure 26. Open-Loop Frequency Response ( $V_{\text{CC}\pm} = \pm 1.35 \text{ V}$ )
- Figure 27. Open-Loop Frequency Response ( $V_{\text{CC}\pm} = \pm 1.6 \text{ V}$ )
- Figure 28. Open-Loop Frequency Response ( $V_{\text{CC}\pm} = \pm 2.5 \text{ V}$ )
- Figure 29. Noninverting Large Signal Pulse Response
- Figure 30. Noninverting Small Signal Pulse Response Figure
- Figure 31. Inverting Large Signal Pulse Response
- Figure 32. Inverting Small Signal Pulse Response
- Figure 33.  $V_{\text{OS}}$  vs  $V_{\text{CM}}$  ( $V_{\text{CC}} = 2.7 \text{ V}$ )
- Figure 34.  $V_{\text{OS}}$  vs  $V_{\text{CM}}$  ( $V_{\text{CC}} = 5 \text{ V}$ )

PACKAGING INFORMATION

Orderable Device	Status <sup>(1)</sup>	Package Type	Package Drawing	Pins	Package Qty	Eco Plan <sup>(2)</sup>	Lead/Ball Finish	MSL Peak Temp <sup>(3)</sup>
LMV710IDBVR	ACTIVE	SOT-23	DBV	5	3000	Green (RoHS & no Sb/Br)	CU NIPDAU	Level-1-260C-UNLIM
LMV710IDBVRE4	ACTIVE	SOT-23	DBV	5	3000	Green (RoHS & no Sb/Br)	CU NIPDAU	Level-1-260C-UNLIM
LMV710IDBVRG4	ACTIVE	SOT-23	DBV	5	3000	Green (RoHS & no Sb/Br)	CU NIPDAU	Level-1-260C-UNLIM
LMV710IDCKR	ACTIVE	SC70	DCK	5	3000	Green (RoHS & no Sb/Br)	CU NIPDAU	Level-1-260C-UNLIM
LMV710IDCKRE4	ACTIVE	SC70	DCK	5	3000	Green (RoHS & no Sb/Br)	CU NIPDAU	Level-1-260C-UNLIM
LMV710IDCKRG4	ACTIVE	SC70	DCK	5	3000	Green (RoHS & no Sb/Br)	CU NIPDAU	Level-1-260C-UNLIM
LMV711IDBVR	ACTIVE	SOT-23	DBV	6	3000	Green (RoHS & no Sb/Br)	CU NIPDAU	Level-1-260C-UNLIM
LMV711IDBVRE4	ACTIVE	SOT-23	DBV	6	3000	Green (RoHS & no Sb/Br)	CU NIPDAU	Level-1-260C-UNLIM
LMV711IDBVRG4	ACTIVE	SOT-23	DBV	6	3000	Green (RoHS & no Sb/Br)	CU NIPDAU	Level-1-260C-UNLIM
LMV711IDCKR	ACTIVE	SC70	DCK	6	3000	Green (RoHS & no Sb/Br)	CU NIPDAU	Level-1-260C-UNLIM
LMV711IDCKRE4	ACTIVE	SC70	DCK	6	3000	Green (RoHS & no Sb/Br)	CU NIPDAU	Level-1-260C-UNLIM
LMV711IDCKRG4	ACTIVE	SC70	DCK	6	3000	Green (RoHS & no Sb/Br)	CU NIPDAU	Level-1-260C-UNLIM
LMV715IDBVR	ACTIVE	SOT-23	DBV	6	3000	Green (RoHS & no Sb/Br)	CU NIPDAU	Level-1-260C-UNLIM
LMV715IDBVRE4	ACTIVE	SOT-23	DBV	6	3000	Green (RoHS & no Sb/Br)	CU NIPDAU	Level-1-260C-UNLIM
LMV715IDBVRG4	ACTIVE	SOT-23	DBV	6	3000	Green (RoHS & no Sb/Br)	CU NIPDAU	Level-1-260C-UNLIM
LMV715IDCKR	ACTIVE	SC70	DCK	6	3000	Green (RoHS & no Sb/Br)	CU NIPDAU	Level-1-260C-UNLIM
LMV715IDCKRE4	ACTIVE	SC70	DCK	6	3000	Green (RoHS & no Sb/Br)	CU NIPDAU	Level-1-260C-UNLIM
LMV715IDCKRG4	ACTIVE	SC70	DCK	6	3000	Green (RoHS & no Sb/Br)	CU NIPDAU	Level-1-260C-UNLIM

<sup>(1)</sup> The marketing status values are defined as follows:

**ACTIVE:** Product device recommended for new designs.

**LIFEBUY:** TI has announced that the device will be discontinued, and a lifetime-buy period is in effect.

**NRND:** Not recommended for new designs. Device is in production to support existing customers, but TI does not recommend using this part in a new design.

**PREVIEW:** Device has been announced but is not in production. Samples may or may not be available.

**OBsolete:** TI has discontinued the production of the device.

<sup>(2)</sup> Eco Plan - The planned eco-friendly classification: Pb-Free (RoHS), Pb-Free (RoHS Exempt), or Green (RoHS & no Sb/Br) - please check <http://www.ti.com/productcontent> for the latest availability information and additional product content details.

**TBD:** The Pb-Free/Green conversion plan has not been defined.

**Pb-Free (RoHS):** TI's terms "Lead-Free" or "Pb-Free" mean semiconductor products that are compatible with the current RoHS requirements for all 6 substances, including the requirement that lead not exceed 0.1% by weight in homogeneous materials. Where designed to be soldered at high temperatures, TI Pb-Free products are suitable for use in specified lead-free processes.

**Pb-Free (RoHS Exempt):** This component has a RoHS exemption for either 1) lead-based flip-chip solder bumps used between the die and

package, or 2) lead-based die adhesive used between the die and leadframe. The component is otherwise considered Pb-Free (RoHS compatible) as defined above.

**Green (RoHS & no Sb/Br):** TI defines "Green" to mean Pb-Free (RoHS compatible), and free of Bromine (Br) and Antimony (Sb) based flame retardants (Br or Sb do not exceed 0.1% by weight in homogeneous material)

<sup>(3)</sup> MSL, Peak Temp. -- The Moisture Sensitivity Level rating according to the JEDEC industry standard classifications, and peak solder temperature.

**Important Information and Disclaimer:**The information provided on this page represents TI's knowledge and belief as of the date that it is provided. TI bases its knowledge and belief on information provided by third parties, and makes no representation or warranty as to the accuracy of such information. Efforts are underway to better integrate information from third parties. TI has taken and continues to take reasonable steps to provide representative and accurate information but may not have conducted destructive testing or chemical analysis on incoming materials and chemicals. TI and TI suppliers consider certain information to be proprietary, and thus CAS numbers and other limited information may not be available for release.

In no event shall TI's liability arising out of such information exceed the total purchase price of the TI part(s) at issue in this document sold by TI to Customer on an annual basis.

**TAPE AND REEL INFORMATION**



**QUADRANT ASSIGNMENTS FOR PIN 1 ORIENTATION IN TAPE**

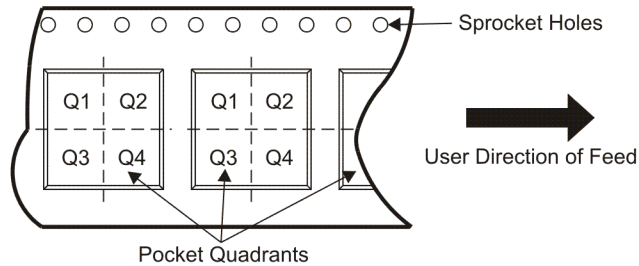

\*All dimensions are nominal

Device	Package Type	Package Drawing	Pins	SPQ	Reel Diameter (mm)	Reel Width W1 (mm)	A0 (mm)	B0 (mm)	K0 (mm)	P1 (mm)	W (mm)	Pin1 Quadrant
LMV710IDBVR	SOT-23	DBV	5	3000	179.0	8.4	3.2	3.2	1.4	4.0	8.0	Q3
LMV710IDCKR	SC70	DCK	5	3000	179.0	8.4	2.2	2.5	1.2	4.0	8.0	Q3
LMV711IDBVR	SOT-23	DBV	6	3000	179.0	8.4	3.2	3.2	1.4	4.0	8.0	Q3
LMV711IDCKR	SC70	DCK	6	3000	179.0	8.4	2.2	2.5	1.2	4.0	8.0	Q3
LMV715IDBVR	SOT-23	DBV	6	3000	179.0	8.4	3.2	3.2	1.4	4.0	8.0	Q3
LMV715IDCKR	SC70	DCK	6	3000	179.0	8.4	2.2	2.5	1.2	4.0	8.0	Q3

**TAPE AND REEL BOX DIMENSIONS**

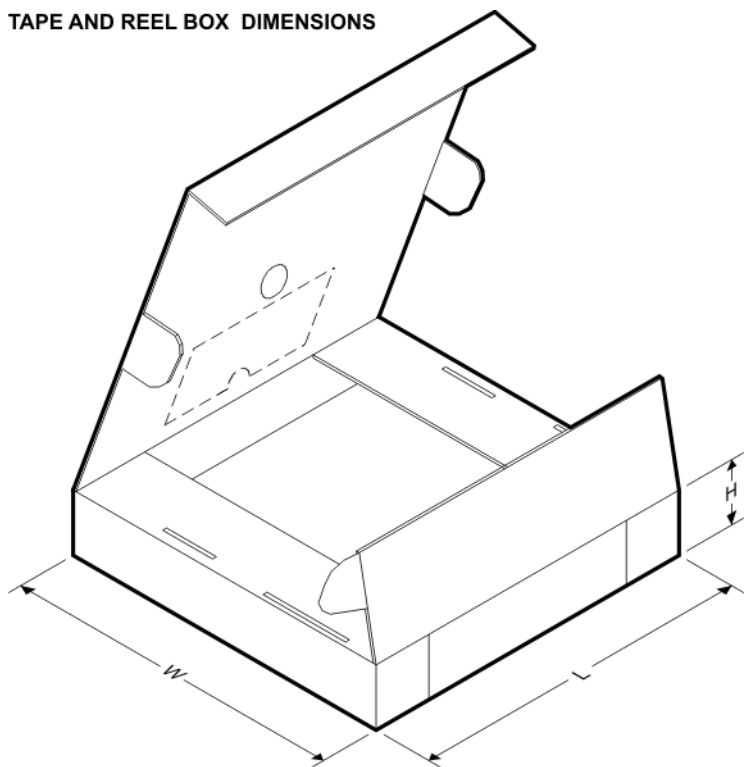

\*All dimensions are nominal

Device	Package Type	Package Drawing	Pins	SPQ	Length (mm)	Width (mm)	Height (mm)
LMV710IDBVR	SOT-23	DBV	5	3000	195.0	200.0	45.0
LMV710IDCKR	SC70	DCK	5	3000	195.0	200.0	45.0
LMV711IDBVR	SOT-23	DBV	6	3000	195.0	200.0	45.0
LMV711IDCKR	SC70	DCK	6	3000	195.0	200.0	45.0
LMV715IDBVR	SOT-23	DBV	6	3000	195.0	200.0	45.0
LMV715IDCKR	SC70	DCK	6	3000	195.0	200.0	45.0





DBV (R-PDSO-G6)

PLASTIC SMALL-OUTLINE PACKAGE

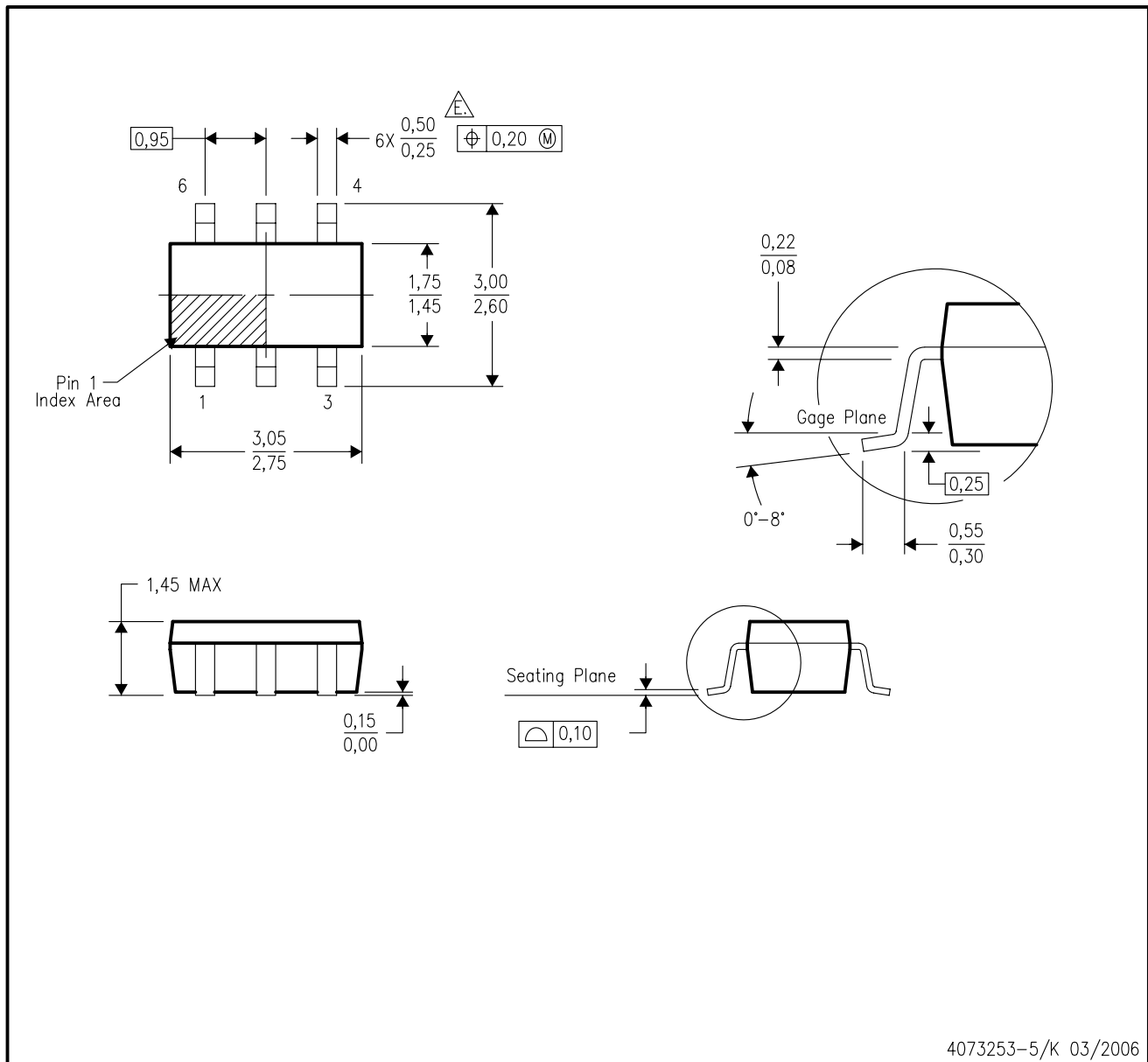

- NOTES:
- A. All linear dimensions are in millimeters.
  - B. This drawing is subject to change without notice.
  - C. Body dimensions do not include mold flash or protrusion. Mold flash and protrusion shall not exceed 0.15 per side.
  - D. Leads 1,2,3 may be wider than leads 4,5,6 for package orientation.
- $\triangle$  Falls within JEDEC MO-178 Variation AB, except minimum lead width.

DCK (R-PDSO-G6)

PLASTIC SMALL-OUTLINE PACKAGE

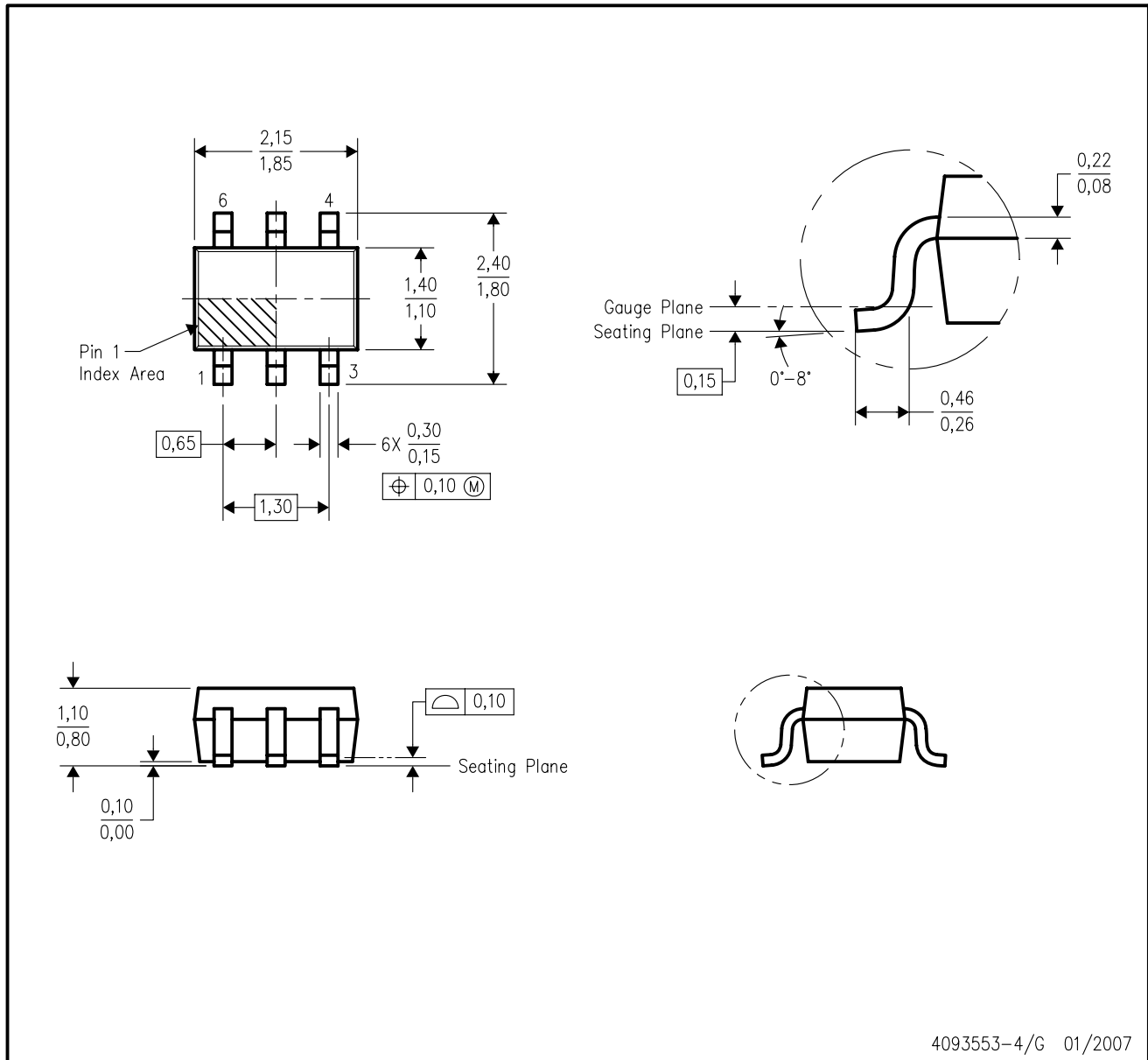

- NOTES:
- A. All linear dimensions are in millimeters.
  - B. This drawing is subject to change without notice.
  - C. Body dimensions do not include mold flash or protrusion. Mold flash and protrusion shall not exceed 0.15 per side.
  - D. Falls within JEDEC MO-203 variation AB.

## DCK (R-PDSO-G6)

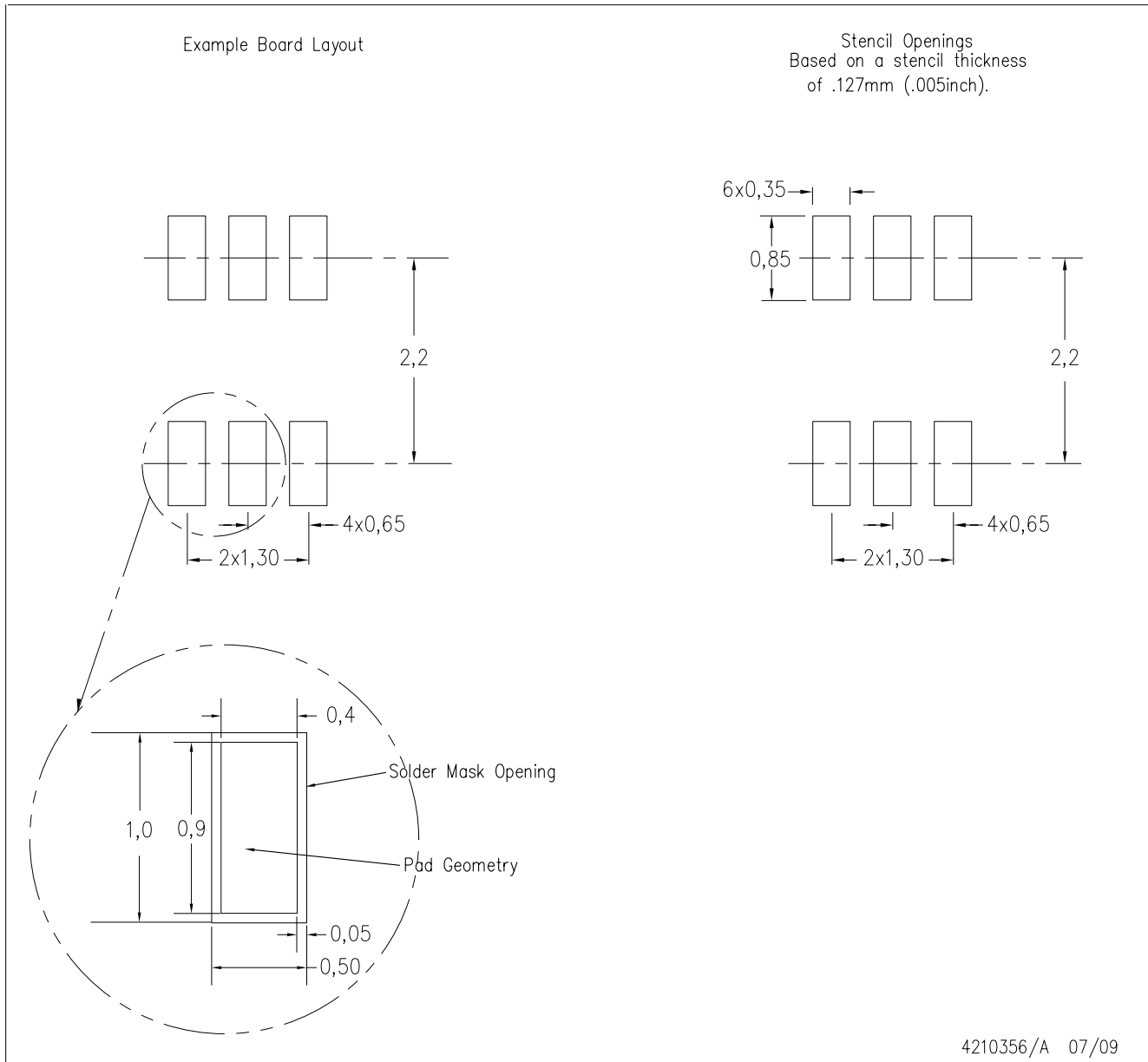

- NOTES:
- All linear dimensions are in millimeters.
  - This drawing is subject to change without notice.
  - Customers should place a note on the circuit board fabrication drawing not to alter the center solder mask defined pad.
  - Publication IPC-7351 is recommended for alternate designs.
  - Laser cutting apertures with trapezoidal walls and also rounding corners will offer better paste release. Customers should contact their board assembly site for stencil design recommendations. Example stencil design based on a 50% volumetric metal load solder paste. Refer to IPC-7525 for other stencil recommendations.

## IMPORTANT NOTICE

Texas Instruments Incorporated and its subsidiaries (TI) reserve the right to make corrections, modifications, enhancements, improvements, and other changes to its products and services at any time and to discontinue any product or service without notice. Customers should obtain the latest relevant information before placing orders and should verify that such information is current and complete. All products are sold subject to TI's terms and conditions of sale supplied at the time of order acknowledgment.

TI warrants performance of its hardware products to the specifications applicable at the time of sale in accordance with TI's standard warranty. Testing and other quality control techniques are used to the extent TI deems necessary to support this warranty. Except where mandated by government requirements, testing of all parameters of each product is not necessarily performed.

TI assumes no liability for applications assistance or customer product design. Customers are responsible for their products and applications using TI components. To minimize the risks associated with customer products and applications, customers should provide adequate design and operating safeguards.

TI does not warrant or represent that any license, either express or implied, is granted under any TI patent right, copyright, mask work right, or other TI intellectual property right relating to any combination, machine, or process in which TI products or services are used. Information published by TI regarding third-party products or services does not constitute a license from TI to use such products or services or a warranty or endorsement thereof. Use of such information may require a license from a third party under the patents or other intellectual property of the third party, or a license from TI under the patents or other intellectual property of TI.

Reproduction of TI information in TI data books or data sheets is permissible only if reproduction is without alteration and is accompanied by all associated warranties, conditions, limitations, and notices. Reproduction of this information with alteration is an unfair and deceptive business practice. TI is not responsible or liable for such altered documentation. Information of third parties may be subject to additional restrictions.

Resale of TI products or services with statements different from or beyond the parameters stated by TI for that product or service voids all express and any implied warranties for the associated TI product or service and is an unfair and deceptive business practice. TI is not responsible or liable for any such statements.

TI products are not authorized for use in safety-critical applications (such as life support) where a failure of the TI product would reasonably be expected to cause severe personal injury or death, unless officers of the parties have executed an agreement specifically governing such use. Buyers represent that they have all necessary expertise in the safety and regulatory ramifications of their applications, and acknowledge and agree that they are solely responsible for all legal, regulatory and safety-related requirements concerning their products and any use of TI products in such safety-critical applications, notwithstanding any applications-related information or support that may be provided by TI. Further, Buyers must fully indemnify TI and its representatives against any damages arising out of the use of TI products in such safety-critical applications.

TI products are neither designed nor intended for use in military/aerospace applications or environments unless the TI products are specifically designated by TI as military-grade or "enhanced plastic." Only products designated by TI as military-grade meet military specifications. Buyers acknowledge and agree that any such use of TI products which TI has not designated as military-grade is solely at the Buyer's risk, and that they are solely responsible for compliance with all legal and regulatory requirements in connection with such use.

TI products are neither designed nor intended for use in automotive applications or environments unless the specific TI products are designated by TI as compliant with ISO/TS 16949 requirements. Buyers acknowledge and agree that, if they use any non-designated products in automotive applications, TI will not be responsible for any failure to meet such requirements.

Following are URLs where you can obtain information on other Texas Instruments products and application solutions:

### Products

Amplifiers	<a href="http://amplifier.ti.com">amplifier.ti.com</a>
Data Converters	<a href="http://dataconverter.ti.com">dataconverter.ti.com</a>
DLP® Products	<a href="http://www.dlp.com">www.dlp.com</a>
DSP	<a href="http://dsp.ti.com">dsp.ti.com</a>
Clocks and Timers	<a href="http://www.ti.com/clocks">www.ti.com/clocks</a>
Interface	<a href="http://interface.ti.com">interface.ti.com</a>
Logic	<a href="http://logic.ti.com">logic.ti.com</a>
Power Mgmt	<a href="http://power.ti.com">power.ti.com</a>
Microcontrollers	<a href="http://microcontroller.ti.com">microcontroller.ti.com</a>
RFID	<a href="http://www.ti-rfid.com">www.ti-rfid.com</a>
RF/IF and ZigBee® Solutions	<a href="http://www.ti.com/lprf">www.ti.com/lprf</a>

### Applications

Audio	<a href="http://www.ti.com/audio">www.ti.com/audio</a>
Automotive	<a href="http://www.ti.com/automotive">www.ti.com/automotive</a>
Broadband	<a href="http://www.ti.com/broadband">www.ti.com/broadband</a>
Digital Control	<a href="http://www.ti.com/digitalcontrol">www.ti.com/digitalcontrol</a>
Medical	<a href="http://www.ti.com/medical">www.ti.com/medical</a>
Military	<a href="http://www.ti.com/military">www.ti.com/military</a>
Optical Networking	<a href="http://www.ti.com/opticalnetwork">www.ti.com/opticalnetwork</a>
Security	<a href="http://www.ti.com/security">www.ti.com/security</a>
Telephony	<a href="http://www.ti.com/telephony">www.ti.com/telephony</a>
Video & Imaging	<a href="http://www.ti.com/video">www.ti.com/video</a>
Wireless	<a href="http://www.ti.com/wireless">www.ti.com/wireless</a>

Mailing Address: Texas Instruments, Post Office Box 655303, Dallas, Texas 75265  
Copyright © 2009, Texas Instruments Incorporated