

1 OMAP3530/25 Applications Processor

1.1 Features

- **OMAP3530/25 Applications Processor:**
 - **OMAP™ 3 Architecture**
 - **MPU Subsystem**
 - Up to 720-MHz ARM Cortex™-A8 Core
 - NEON™ SIMD Coprocessor
 - **High Performance Image, Video, Audio (IVA2.2™) Accelerator Subsystem**
 - Up to 520-MHz TMS320C64x+™ DSP Core
 - Enhanced Direct Memory Access (EDMA) Controller (128 Independent Channels)
 - Video Hardware Accelerators
 - **POWERVR SGX™ Graphics Accelerator (OMAP3530 Device Only)**
 - Tile Based Architecture Delivering up to 10 MPoly/sec
 - Universal Scalable Shader Engine: Multi-threaded Engine Incorporating Pixel and Vertex Shader Functionality
 - Industry Standard API Support: OpenGL ES 1.1 and 2.0, OpenVG1.0
 - Fine Grained Task Switching, Load Balancing, and Power Management
 - Programmable High Quality Image Anti-Aliasing
 - **Fully Software-Compatible With C64x and ARM9™**
 - **Commercial and Extended Temperature Grades**
- **Advanced Very-Long-Instruction-Word (VLIW) TMS320C64x+™ DSP Core**
 - **Eight Highly Independent Functional Units**
 - +Six ALUs (32-/40-Bit), Each Supports Single 32-Bit, Dual 16-Bit, or Quad 8-Bit Arithmetic per Clock Cycle
 - Two Multipliers Support Four 16 x 16-Bit Multiplies (32-Bit Results) per Clock Cycle or Eight 8 x 8-Bit Multiplies (16-Bit Results) per Clock Cycle
 - **Load-Store Architecture With Non-Aligned Support**
 - **64 32-Bit General-Purpose Registers**
 - **Instruction Packing Reduces Code Size**
 - **All Instructions Conditional**
- **Additional C64x+™ Enhancements**
 - Protected Mode Operation
 - Exceptions Support for Error Detection and Program Redirection
 - Hardware Support for Modulo Loop Operation
- **C64x+ L1/L2 Memory Architecture**
 - **32K-Byte L1P Program RAM/Cache (Direct Mapped)**
 - **80K-Byte L1D Data RAM/Cache (2-Way Set-Associative)**
 - **64K-Byte L2 Unified Mapped RAM/Cache (4-Way Set-Associative)**
 - **32K-Byte L2 Shared SRAM and 16K-Byte L2 ROM**
- **C64x+ Instruction Set Features**
 - **Byte-Addressable (8-/16-/32-/64-Bit Data)**
 - **8-Bit Overflow Protection**
 - **Bit-Field Extract, Set, Clear**
 - **Normalization, Saturation, Bit-Counting**
 - **Compact 16-Bit Instructions**
 - **Additional Instructions to Support Complex Multiplies**
- **ARM Cortex™-A8 Core**
 - **ARMv7 Architecture**
 - Trust Zone®
 - Thumb®-2
 - MMU Enhancements
 - **In-Order, Dual-Issue, Superscalar Microprocessor Core**
 - **NEON™ Multimedia Architecture**
 - **Over 2x Performance of ARMv6 SIMD**
 - **Supports Both Integer and Floating Point SIMD**
 - **Jazelle® RCT Execution Environment Architecture**
 - **Dynamic Branch Prediction with Branch Target Address Cache, Global History Buffer, and 8-Entry Return Stack**
 - **Embedded Trace Macrocell (ETM) Support for Non-Invasive Debug**
- **ARM Cortex™-A8 Memory Architecture:**
 - **16K-Byte Instruction Cache (4-Way Set-Associative)**



Please be aware that an important notice concerning availability, standard warranty, and use in critical applications of Texas Instruments semiconductor products and disclaimers thereto appears at the end of this document.

POWERVR SGX is a trademark of Imagination Technologies Ltd.

OMAP is a trademark of Texas Instruments.

All other trademarks are the property of their respective owners.

- 16K-Byte Data Cache (4-Way Set-Associative)
- 256K-Byte L2 Cache
- 112K-Byte ROM
- 64K-Byte Shared SRAM
- Endianness:
 - ARM Instructions - Little Endian
 - ARM Data – Configurable
 - DSP Instruction/Data - Little Endian
- External Memory Interfaces:
 - SDRAM Controller (SDRC)
 - 16, 32-bit Memory Controller With 1G-Byte Total Address Space
 - Interfaces to Low-Power Double Data Rate (LPDDR) SDRAM
 - SDRAM Memory Scheduler (SMS) and Rotation Engine
 - General Purpose Memory Controller (GPMC)
 - 16-bit Wide Multiplexed Address/Data Bus
 - Up to 8 Chip Select Pins With 128M-Byte Address Space per Chip Select Pin
 - Glueless Interface to NOR Flash, NAND Flash (With ECC Hamming Code Calculation), SRAM and Pseudo-SRAM
 - Flexible Asynchronous Protocol Control for Interface to Custom Logic (FPGA, CPLD, ASICs, etc.)
 - Nonmultiplexed Address/Data Mode (Limited 2K-Byte Address Space)
- System Direct Memory Access (sDMA) Controller (32 Logical Channels With Configurable Priority)
- Camera Image Signal Processing (ISP)
 - CCD and CMOS Imager Interface
 - Memory Data Input
 - RAW Data Interface
 - BT.601/BT.656 Digital YCbCr 4:2:2 (8-/10-Bit) Interface
 - A-Law Compression and Decompression
 - Preview Engine for Real-Time Image Processing
 - Glueless Interface to Common Video Decoders
 - Histogram Module/Auto-Exposure, Auto-White Balance, and Auto-Focus Engine
 - Resize Engine
 - Resize Images From 1/4x to 4x
 - Separate Horizontal/Vertical Control
- Display Subsystem
 - Parallel Digital Output
 - Up to 24-Bit RGB
 - HD Maximum Resolution
 - Supports Up to 2 LCD Panels
 - Support for Remote Frame Buffer Interface (RFBI) LCD Panels
 - 2 10-Bit Digital-to-Analog Converters (DACs) Supporting:
 - Composite NTSC/PAL Video
 - Luma/Chroma Separate Video (S-Video)
 - Rotation 90-, 180-, and 270-degrees
 - Resize Images From 1/4x to 8x
 - Color Space Converter
 - 8-bit Alpha Blending
- Serial Communication
 - 5 Multichannel Buffered Serial Ports (McBSPs)
 - 512 Byte Transmit/Receive Buffer (McBSP1/3/4/5)
 - 5K-Byte Transmit/Receive Buffer (McBSP2)
 - SIDETONE Core Support (McBSP2 and 3 Only) For Filter, Gain, and Mix Operations
 - Direct Interface to I2S and PCM Device and TDM Buses
 - 128 Channel Transmit/Receive Mode
 - Four Master/Slave Multichannel Serial Port Interface (McSPI) Ports
 - High-Speed/Full-Speed/Low-Speed USB OTG Subsystem (12-/8-Pin ULPI Interface)
 - High-Speed/Full-Speed/Low-Speed Multiport USB Host Subsystem
 - 12-/8-Pin ULPI Interface or 6-/4-/3-Pin Serial Interface
 - Supports Transceiverless Link Logic (TLL)
 - One HDQ/1-Wire Interface
 - Three UARTs (One with Infrared Data Association [IrDA] and Consumer Infrared [CIR] Modes)
 - Three Master/Slave High-Speed Inter-Integrated Circuit (I2C) Controllers
- Removable Media Interfaces:
 - Three Multimedia Card (MMC)/ Secure Digital (SD) With Secure Data I/O (SDIO)
- Comprehensive Power, Reset, and Clock Management
 - SmartReflex™ Technology
 - Dynamic Voltage and Frequency Scaling (DVFS)
- Test Interfaces
 - IEEE-1149.1 (JTAG) Boundary-Scan Compatible

- Embedded Trace Macro Interface (ETM)
- Serial Data Transport Interface (SDTI)
- 12 32-bit General Purpose Timers
- 2 32-bit Watchdog Timers
- 1 32-bit 32-kHz Sync Timer
- Up to 188 General-Purpose I/O (GPIO) Pins (Multiplexed With Other Device Functions)
- 65-nm CMOS Technology
- Package-On-Package (POP) Implementation for Memory Stacking (Not Available in CUS Package)
- Discrete Memory Interface (Not Available in CBC Package)
- Packages:
 - 515-pin s-PBGA package (CBB Suffix), .5mm Ball Pitch (Top), .4mm Ball Pitch (Bottom)
 - 515-pin s-PBGA package (CBC Suffix), .65mm Ball Pitch (Top), .5mm Ball Pitch (Bottom)
 - 423-pin s-PBGA package (CUS Suffix), .65mm Ball Pitch
- 1.8-V I/O and 3.0-V (MMC1 only), 0.985-V to 1.35-V Adaptive Processor Core Voltage
0.985-V to 1.35-V Adaptive Core Logic Voltage
Note: These are default Operating Performance Point (OPP) voltages and could be optimized to lower values using SmartReflex™ AVS.
- Applications:
 - Portable Navigation Devices
 - Portable Media Player
 - Advanced Portable Consumer Electronics
 - Digital TV
 - Digital Video Camera
 - Portable Data Collection
 - Point-of-Sale Devices
 - Gaming
 - Web Tablet
 - Smart White Goods
 - Smart Home Controllers
 - Ultra Mobile Devices

1.2 Description

OMAP3530 and OMAP3525 high-performance, applications processors are based on the enhanced OMAP™ 3 architecture.

The OMAP™ 3 architecture is designed to provide best-in-class video, image, and graphics processing sufficient to support the following:

- Streaming video
- 3D mobile gaming
- Video conferencing
- High-resolution still image

The device supports high-level operating systems (OSs), such as:

- Linux
- Windows CE

This OMAP device includes state-of-the-art power-management techniques required for high-performance mobile products.

The following subsystems are part of the device:

- Microprocessor unit (MPU) subsystem based on the ARM Cortex™-A8 microprocessor
- IVA2.2 subsystem with a C64x+ digital signal processor (DSP) core
- POWERVR SGX™ subsystem for 3D graphics acceleration to support display and gaming effects (3530 only)
- Camera image signal processor (ISP) that supports multiple formats and interfacing options connected to a wide variety of image sensors
- Display subsystem with a wide variety of features for multiple concurrent image manipulation, and a programmable interface supporting a wide variety of displays. The display subsystem also supports NTSC/PAL video out.
- Level 3 (L3) and level 4 (L4) interconnects that provide high-bandwidth data transfers for multiple initiators to the internal and external memory controllers and to on-chip peripherals

The device also offers:

- A comprehensive power and clock-management scheme that enables high-performance, low-power operation, and ultralow-power standby features. The device also supports SmartReflex™ adaptive voltage control. This power management technique for automatic control of the operating voltage of a module reduces the active power consumption.
- Memory stacking feature using the package-on-package (POP) implementation (CBB and CBC packages only)

OMAP30/25 devices are available in a 515-pin s-PBGA package (CBB suffix), 515-pin s-PBGA package (CBC suffix), and a 423-pin s-PBGA package (CUS suffix). Some features of the CBB and CBC packages are not available in the CUS package.

[Table 1-1](#) lists the differences between the CBB, CBC, and CUS packages.

Table 1-1. Differences Between CBB, CBC, and CUS Packages

| FEATURE | CBB PACKAGE | CBC PACKAGE | CUS PACKAGE |
|------------------------------------|---|---|---|
| Pin Assignments | For CBB package pin assignments see, <i>Ball Characteristics (CBB Pkg.)</i> | For CBC package pin assignments see, <i>Ball Characteristics (CBC Pkg.)</i> | For CUS package pin assignments see, <i>Ball Characteristics (CUS Pkg.)</i> |
| Package-On-Package (POP) Interface | POP interface supported | POP interface supported | POP interface not available |
| Discrete Memory Interface | Discrete Memory Interface supported | Discrete Memory Interface not supported | Discrete Memory Interface supported |
| GPMC | Eight chip select pins available | Eight chip select pins available | Chip select pins gpmc_ncs1 and gpmc_ncs2 are not available |
| | Four wait pins available | Four wait pins available | Wait pins gpmc_wait1 and gpmc_wait2 are not available |
| UART1 | CTS signal is available on 3 pins (triple muxed): uart1_cts (AG22 / W8 / T21), uart1_rts (AH22 / AA9), uart1_tx (F28 / Y8 / AE7), uart1_rx (E26 / AA8) | The following signals are either available on two (double muxed) or three pins (triple muxed): uart1_cts (AE21 / T19 / W2), uart1_rts (AE22 / R2), uart1_rx (H3 / H25 / AE4), uart1_tx (L4 / G26) | CTS signal is available on 3 pins (triple muxed): uart1_cts (AC19 / AC2 / AA18), uart1_rts (W6 / AB19), uart1_tx (E23 / V7 / AC3), uart1_rx (D24 / W7) |
| UART2 | The following signals are available on two pins (double muxed): uart2_cts (AF6/AB26), uart2_rts (AE6/AB25), uart2_tx (AF5/AA25), uart2_rx (AE5/AD25) | The following signals are available on two pins (double muxed): uart2_cts (Y24/P3), uart2_rts (AA24/N3), uart2_tx (AD22/U3), uart2_rx (AD21/W3) | The following signals are available on one pin only: uart2_cts (V6), uart2_rts (V5), uart2_tx (W4), uart2_rx (V4) |
| McBSP3 | The following signals are available on three pins (triple muxed): mcbbsp3_dx (AF6 / AB26 / V21), mcbbsp3_dr (AE6 / AB25 / U21), mcbbsp3_clkx (AF5 / AA25 / W21), and mcbbsp3_fsx (AE5 / AD25 / K26) | The following signals are available on two pins (triple muxed): mcbbsp3_dx (U17/ Y24/ P3), mcbbsp3_dr (T20/ AA24 / N3), mcbbsp3_clkx (T17/ AD22 / U3), mcbbsp3_fsx (P20/ AD21 / W3) | The following signals are available on two pins only (double muxed): mcbbsp3_dx (V6/W18), mcbbsp3_dr (V5/Y18), mcbbsp3_clkx (W4/V18), and mcbbsp3_fsx (V4/AA19) |
| GP Timer | The following signals are available on three pins (triple muxed): gpt8_pwm_evt (N8 / AD25 / V3), gpt9_pwm_evt (T8 / AB26 / Y2), gpt10_pwm_evt (R8 / AB25 / Y3), and gpt11_pwm_evt (P8 / AA25 / Y4) | The following signals are available on three pins (triple muxed): gpt8_pwm_evt (C5/AD21/V9), gpt9_pwm_evt (B4/W8/Y24), gpt10_pwm_evt(C4/U8/AA24), gpt11_pwm_evt(B5/V8/AD22) | The following signals are available on two pins only (double muxed): gpt8_pwm_evt (G4/M4), gpt9_pwm_evt (F4/N4), gpt10_pwm_evt (G5/N3), and gpt11_pwm_evt (F3/M5) |
| McBSP4 | The following signals are available on two pins (double muxed): mcbbsp4_clkx (T8/AE1), mcbbsp4_dr (R8/AD1), mcbbsp4_dx (P8/AD2), mcbbsp4_fsx (N8/AC1) | The following signals are available on two pins (double muxed): mcbbsp4_clkx (B4 / V3), mcbbsp4_dr (C4 / U4), mcbbsp4_dx (B5 / R3), mcbbsp4_fsx (C5 / T3) | The following signals are available on one pin only: mcbbsp4_clkx (F4), mcbbsp4_dr (G5), mcbbsp4_dx (F3), mcbbsp4_fsx (G4) |
| HSUSB3_TLL | Supported | Supported | Not supported |
| MM_FSUSB3 | Supported | Supported | Not supported |
| McSPI1 | Four chip select pins are available | Four chip select pins are available | Chip select pins mcspi1_cs1 and mcspi1_cs2 are not available |
| MMC3 | The following signals are available on two pins (double muxed): mmc3_cmd (AC3 / AE10), and mmc3_clk (AB1 / AF10) | The following signals are available on two pins (double muxed): mmc3_cmd (R8 / AB3), mmc3_clk (R9 / AB2) | The following signals are available on one pin only: mmc3_cmd (AD3), and mmc3_clk (AC1) |

Table 1-1. Differences Between CBB, CBC, and CUS Packages (continued)

| FEATURE | CBB PACKAGE | CBC PACKAGE | CUS PACKAGE |
|---------|---|---|---|
| GPIO | A maximum of 188 GPIO pins are supported. | A maximum of 188 GPIO pins are supported. | <p>A maximum of 170 GPIO pins are supported.</p> <p>The following GPIO pins are not available: gpio_112, gpio_113, gpio_114, gpio_115, gpio_52, gpio_53, gpio_63, gpio_64, gpio_144, gpio_145, gpio_146, gpio_147, gpio_152, gpio_153, gpio_154, gpio_155, gpio_175, and gpio_176.</p> <p>Pin muxing restricts the total number of GPIO pins available at one time. For more details, see , <i>Multiplexing Characteristics (CUS Pkg.)</i>.</p> |

This OMAP3530/25 Applications Processor data manual presents the electrical and mechanical specifications for the OMAP3530/25 Applications Processor. The information contained in this data manual applies to both the commercial and extended temperature versions of the OMAP3530/25 Applications Processor unless otherwise indicated. It consists of the following sections:

- A description of the OMAP3530/25 terminals: assignment, electrical characteristics, multiplexing, and functional description ([Section 2](#))
- A presentation of the electrical characteristics requirements: power domains, operating conditions, power consumption, and dc characteristics ([Section 3](#))
- The clock specifications: input and output clocks, DPLL and DLL ([Section 4](#))
- The video DAC specification ([Section 5](#))
- The timing requirements and switching characteristics (ac timings) of the interfaces ([Section 6](#))
- A description of thermal characteristics, device nomenclature, and mechanical data about the available packaging ([Section 7](#))

1.3 Functional Block Diagram

Figure 1-1 shows the functional block diagram of the OMAP3530/25 Applications Processor.

OMAP Applications Processor

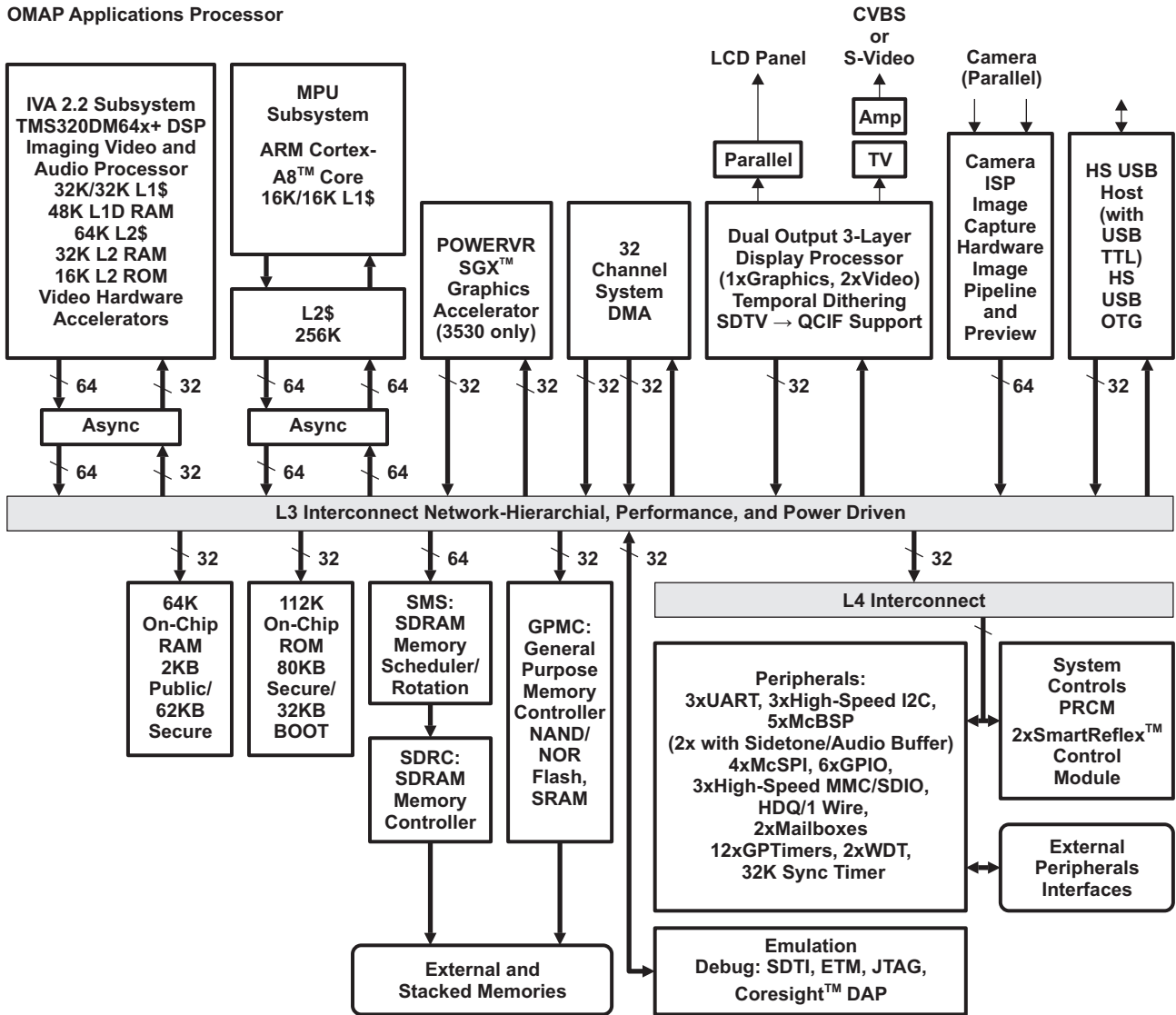

Figure 1-1. OMAP3530/25 Functional Block Diagram

Contents

| | | | | | |
|-------------------------------|---|----------------------------|----------|--|----------------------------|
| 1 | OMAP3530/25 Applications Processor | 1 | 4.3 | DPLL and DLL Specifications | 141 |
| 1.1 | Features | 1 | 5 | VIDEO DAC SPECIFICATIONS | 147 |
| 1.2 | Description | 4 | 5.1 | Interface Description | 147 |
| 1.3 | Functional Block Diagram | 7 | 5.2 | Electrical Specifications Over Recommended Operating Conditions | 149 |
| Revision History | | 9 | 5.3 | Analog Supply (vdda_dac) Noise Requirements .. | 151 |
| 2 | TERMINAL DESCRIPTION | 10 | 5.4 | External Component Value Choice | 152 |
| 2.1 | Terminal Assignment | 10 | 6 | TIMING REQUIREMENTS AND SWITCHING CHARACTERISTICS | 153 |
| 2.2 | Pin Assignments | 14 | 6.1 | Timing Test Conditions | 153 |
| 2.3 | Ball Characteristics | 27 | 6.2 | Interface Clock Specifications | 153 |
| 2.4 | Multiplexing Characteristics | 86 | 6.3 | Timing Parameters | 154 |
| 2.5 | Signal Description | 94 | 6.4 | External Memory Interfaces | 155 |
| 3 | ELECTRICAL CHARACTERISTICS | 119 | 6.5 | Video Interfaces | 184 |
| 3.1 | Power Domains | 119 | 6.6 | Serial Communications Interfaces | 201 |
| 3.2 | Absolute Maximum Ratings | 121 | 6.7 | Removable Media Interfaces | 234 |
| 3.3 | Recommended Operating Conditions | 123 | 6.8 | Test Interfaces | 249 |
| 3.4 | DC Electrical Characteristics | 125 | 7 | PACKAGE CHARACTERISTICS | 255 |
| 3.5 | Core Voltage Decoupling | 128 | 7.1 | Package Thermal Resistance | 255 |
| 3.6 | Power-up and Power-down | 130 | 7.2 | Device Support | 255 |
| 4 | CLOCK SPECIFICATIONS | 133 | | | |
| 4.1 | Input Clock Specifications | 134 | | | |
| 4.2 | Output Clock Specifications | 139 | | | |

Revision History

NOTE: Page numbers for previous revisions may differ from page numbers in the current version.

This data manual revision history table highlights the technical changes made to the SPRS507E device-specific data manual to make it an SPRS507F revision.

Scope: This data manual revision includes a global update to CBB, CBC, and CUS-package Terminal Descriptions.

| SEE | ADDITIONS/MODIFICATIONS/DELETIONS |
|--------------------------------|---|
| "Terminal Description" section | Updated/Changed the following tables for CBB, CBC, and CUS packages: <ul style="list-style-type: none"> • Ball Characteristics • Multiplexing Characteristics • Signal Description |
| | Added Pin Maps (Top View) for CBB, CBC, and CUS packages |
| | Updated/Changed CBC Package Terminal Assignment (Bottom View) illustration |

2 TERMINAL DESCRIPTION

2.1 Terminal Assignment

Figure 2-1 through Figure 2-5 show the ball locations for the 515- and 423- ball plastic ball grid array (s-PBGA) packages. through Table 2-25 indicate the signal names and ball grid numbers for both packages.

Note: There are no balls present on the top of the 423-ball s-PBGA package.

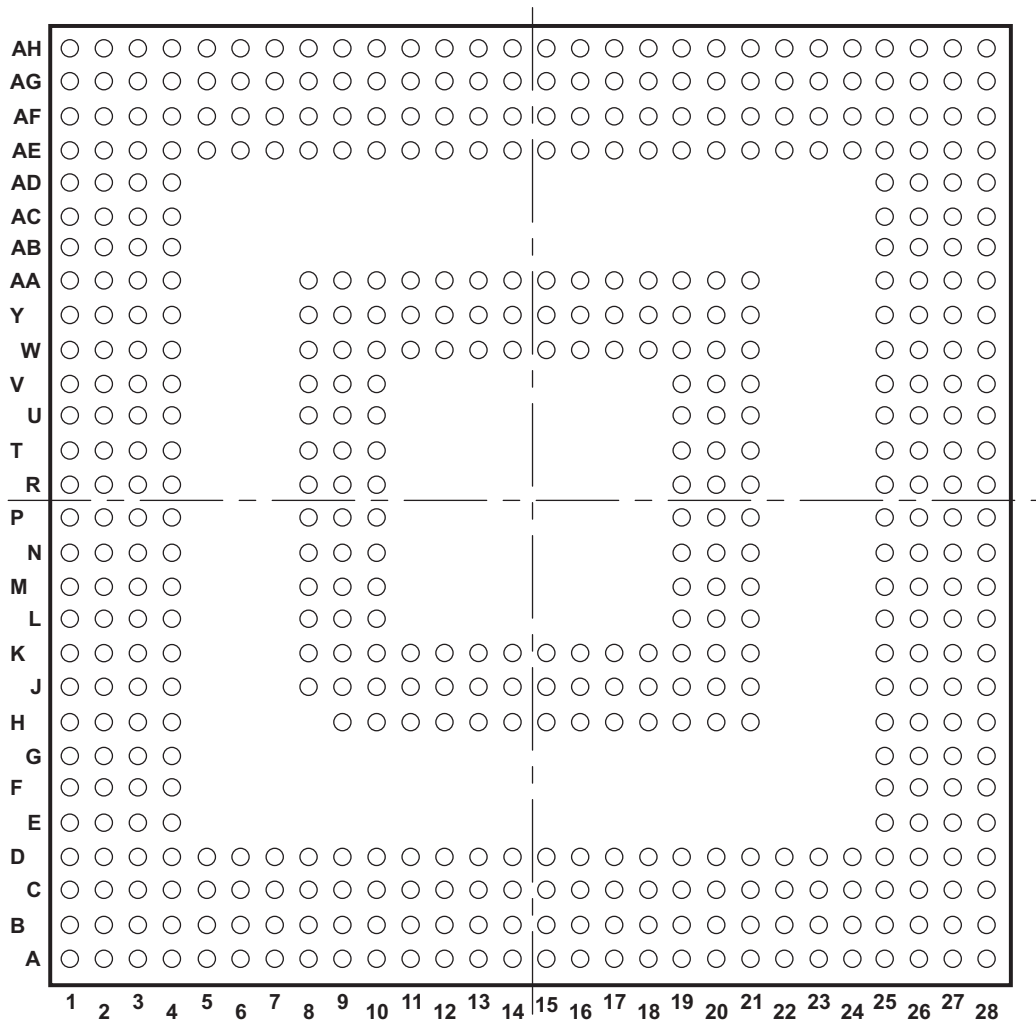

030-001

Figure 2-1. OMAP3530/25 Applications Processor CBB s-PBGA-N515 Package (Bottom View)

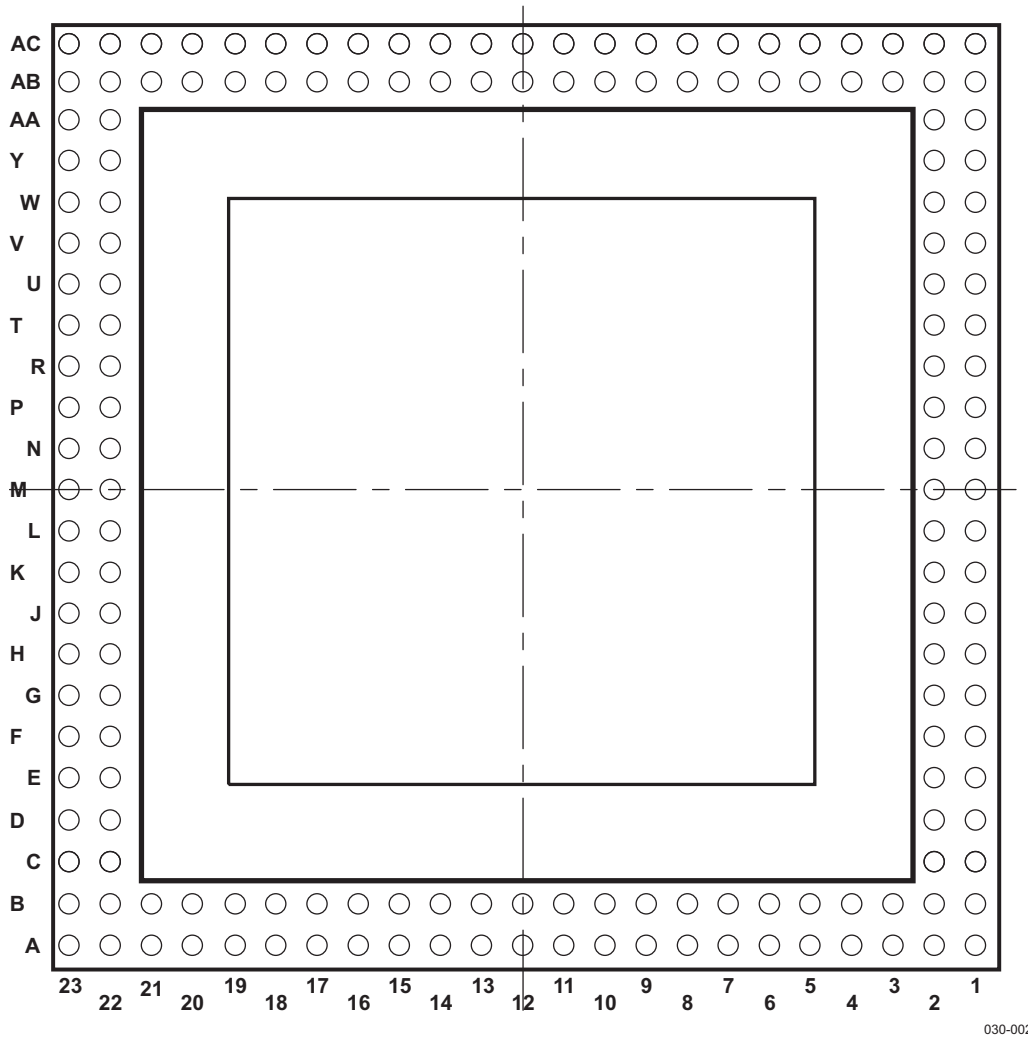

030-002

Balls A1, A2, A22, A23, AB1, AB2, AB22, AB23, AC1, AC2, AC22, AC23, B1, B2, B22, and B23 are unused.

Figure 2-2. OMAP3530/25 Applications Processor CBB s-PBGA-N515 Package (Top View)

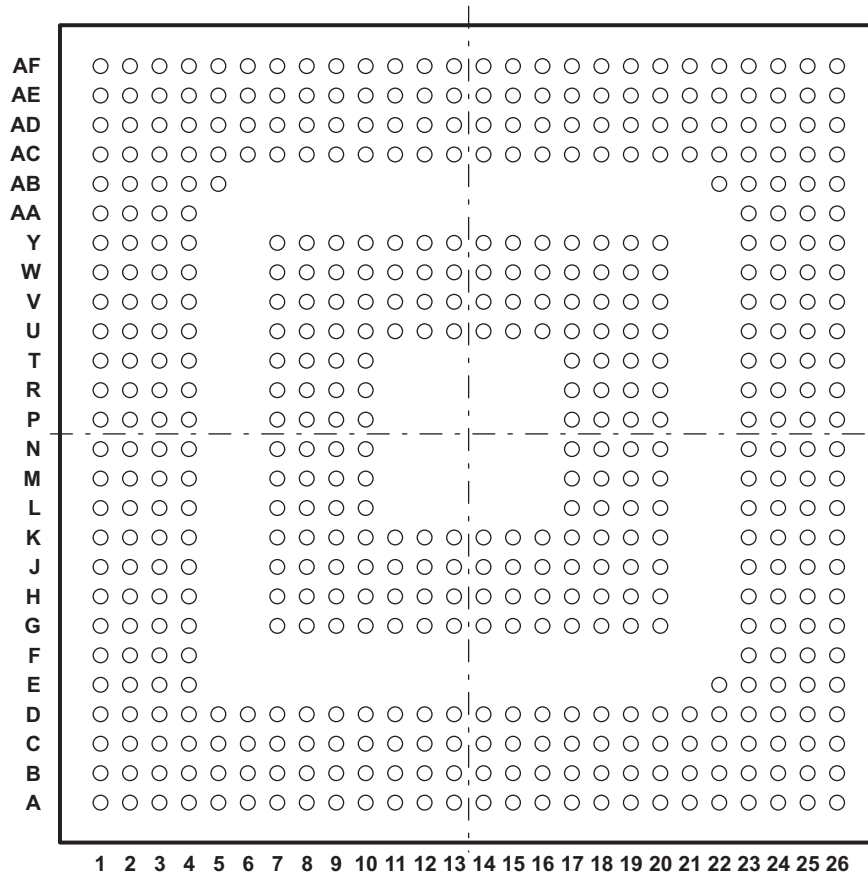

Figure 2-3. OMAP3530/25 Applications Processor CBC s-PBGA-515 Package (Bottom View)

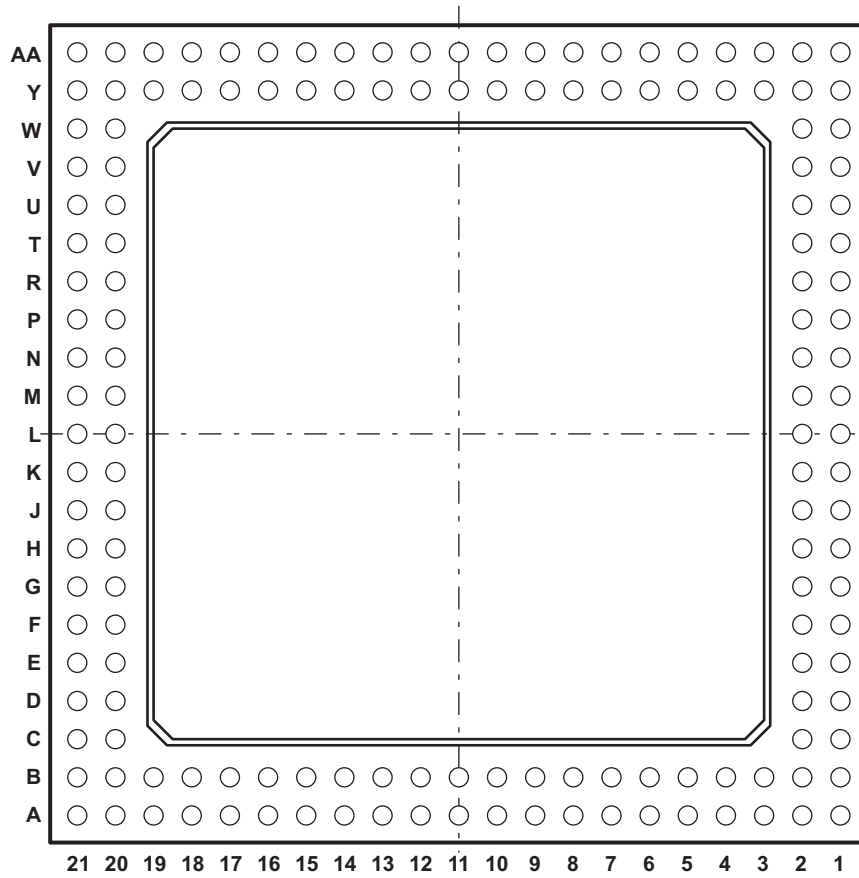

Figure 2-4. OMAP3530/25 Applications Processor CBC s-PBGA-515 Package (Top View)

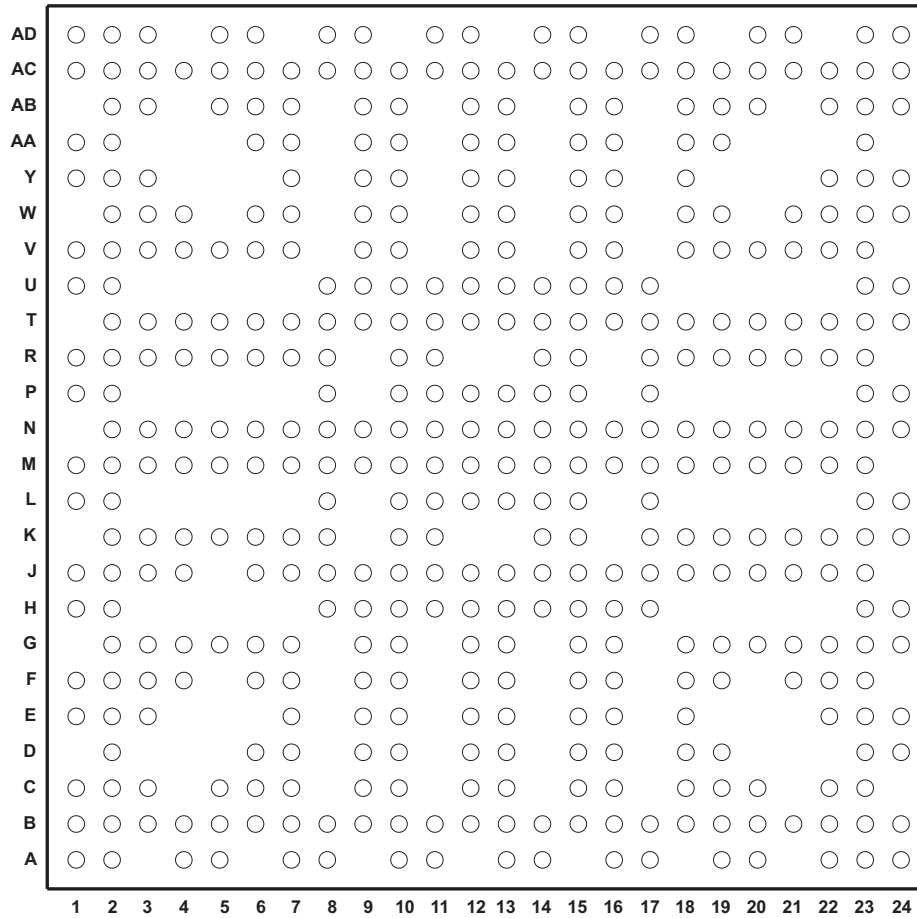

Figure 2-5. OMAP3530/25 Applications Processor CUS s-PBGA-N423 Package (Bottom View)

2.2 Pin Assignments

2.2.1 Pin Map (Top View)

The following pin maps show the top views of the 515-pin sPBGA package **[CBB]**, the 515-pin sPBGA package **[CBC]**, and the 423-pin sPBGA package **[CUS]** pin assignments in four quadrants (A, B, C, and D).

| | 1 | 2 | 3 | 4 | 5 | 6 | 7 | 8 | 9 | 10 | 11 | 12 | 13 | 14 | | | | | | | | | |
|---|------------|-----------|---------------|-----------|----------|-----------|----------|----------|----------|-----------|----------|----------|----------|-----------|------------|-------------|-------------|-------------|-----------|-------------|-------------|--|--|
| A | pop_a1_a1 | pop_a2_a2 | vss | sdrc_a0 | vdds_mem | sdrc_dqs0 | sdrc_d5 | vdds_mem | sdrc_d7 | sdrc_dqs2 | sdrc_d21 | vdds_mem | sdrc_clk | sdrc_nclk | | | | | | | | | |
| B | pop_b1_b1 | vss | sdrc_a2 | sdrc_a1 | vdds_mem | sdrc_d2 | sdrc_dm0 | vdds_mem | sdrc_d6 | sdrc_d17 | sdrc_dm2 | vdds_mem | sdrc_d22 | sdrc_d9 | | | | | | | | | |
| C | sdrc_a8 | sdrc_a7 | sdrc_a6 | sdrc_a4 | sdrc_a3 | sdrc_d1 | vss | sdrc_d3 | sdrc_d4 | vss | sdrc_d18 | sdrc_d20 | vss | sdrc_d8 | | | | | | | | | |
| D | sdrc_a12 | sdrc_a11 | sdrc_a10 | sdrc_a9 | sdrc_a5 | sdrc_d0 | vss | vdd_core | vdd_core | vss | sdrc_d16 | sdrc_d19 | vss | sdrc_d23 | | | | | | | | | |
| E | sdrc_a14 | sdrc_a13 | vss | vss | | | | | | | | | | | | | | | | | | | |
| F | vdds_mem | vdds_mem | gpmc_nadv_ale | gpmc_nwe | | | | | | | | | | | | | | | | | | | |
| G | NC | gpmc_noe | gpmc_nbe0_cle | gpmc_ncs0 | | | | | | | | | | | | | | | | | | | |
| H | gpmc_nwp | gpmc_d8 | gpmc_ncs1 | vdd_core | | | | | | | | | | | sdrc_ba0 | sdrc_ba1 | sdrc_ncs0 | sdrc_ncs1 | sdrc_ncas | sdrc_nras | | | |
| J | vdds_mem | vdds_mem | vss | vdd_core | | | | | | | | | | | gpmc_wait3 | vdd_mpu_iva | vdd_mpu_iva | vdd_mpu_iva | vss | vss | vdd_mpu_iva | | |
| K | gpmc_d0 | gpmc_d9 | gpmc_a10 | gpmc_a4 | | | | | | | | | | | gpmc_wait2 | vss | vss | vdd_mpu_iva | vss | vdd_mpu_iva | vdd_mpu_iva | | |
| L | gpmc_d1 | gpmc_d2 | gpmc_a9 | gpmc_a3 | | | | | | | | | | | gpmc_wait1 | vdd_mpu_iva | vdd_mpu_iva | | | | | | |
| M | pop_y23_m1 | pop_k2_m2 | gpmc_a8 | gpmc_a2 | | | | | | | | | | | gpmc_wait0 | vdd_mpu_iva | vdd_mpu_iva | | | | | | |
| N | pop_u1_n1 | pop_l2_n2 | gpmc_a7 | gpmc_a1 | | | | | | | | | | | gpmc_ncs7 | vss | vdd_mpu_iva | | | | | | |
| P | gpmc_d10 | gpmc_d3 | vss | vss | | | | | | | | | | | gpmc_ncs6 | vss | vss | | | | | | |



A. Top Views are provided to assist in hardware debugging efforts.

Figure 2-6. CBB Pin Map [Quadrant A - Top View]

| | 15 | 16 | 17 | 18 | 19 | 20 | 21 | 22 | 23 | 24 | 25 | 26 | 27 | 28 | |
|---|----------------|-----------|------------|-----------|-----------|------------|-------------------|------------|-------------|-------------|------------|------------|-------------|----------------|--------------|
| A | pop_a12_a15 | sdr_c_dm1 | sdr_c_dqs1 | vdds_mem | sdr_c_d25 | sdr_c_dqs3 | sdr_c_d29 | vdds_mem | cam_vs | cam_hs | cam_d5 | vss | pop_a22_a27 | pop_a23_a28 | |
| B | pop_b12_b15 | sdr_c_d11 | sdr_c_d14 | vdds_mem | sdr_c_d26 | sdr_c_d27 | sdr_c_d30 | vdds_mem | cam_wen | cam_d2 | cam_d10 | cam_xclkb | vss | pop_b23_b28 | |
| C | sdr_c_d10 | vdds_mem | sdr_c_d13 | sdr_c_d24 | vss | sdr_c_dm3 | sdr_c_d31 | vss | cam_fld | cam_d3 | cam_xclka | cam_d11 | cam_pclk | vdds_mem | |
| D | vdd_core | vdds_mem | sdr_c_d12 | sdr_c_d15 | vss | sdr_c_d28 | vss | vdd_core | vdd_core | cam_d4 | cam_strobe | dss_hsync | dss_vsync | dss_pclk | |
| E | | | | | | | | | | | vdd_core | dss_data6 | dss_acbias | dss_data20 | |
| F | | | | | | | | | | | vdds | vdds | dss_data8 | dss_data7 | |
| G | | | | | | | | | | | dss_data16 | dss_data9 | vss | vdds_mem | |
| H | | | | | | | | | | | sdr_c_nwe | sdr_c_cke0 | sdr_c_cke1 | uart3_cts_rctx | uart3_rts_sd |
| J | vdd_mpu_iva | vss | vss | vdd_core | vdd_core | vdd_core | i2c1_sda | hdq_sio | dss_data21 | pop_h22_j27 | pop_k1_j28 | | | | |
| K | vdds_dppll_dll | vss | vss | vdd_core | vss | vdd_core | i2c1_scl | vdds_mmc1 | mcbsp1_fsx | cam_d8 | cam_d6 | | | | |
| L | | | | | vss | vss | cap_vdd_sram_core | vdd_core | vss | cam_d9 | cam_d7 | | | | |
| M | | | | | vdd_core | vss | mcbsp2_dx | vdd_core | pop_k22_m26 | mmc1_cmd | vss | | | | |
| N | | | | | vdd_core | vdd_core | mcbsp2_clkx | mmc1_dat2 | mmc1_dat1 | mmc1_dat0 | mmc1_clk | | | | |
| P | | | | | vss | vdd_core | mcbsp2_fsx | vdds_mmc1a | mmc1_dat5 | mmc1_dat4 | mmc1_dat3 | | | | |

Figure 2-7. CBB Pin Map [Quadrant B - Top View]



| | | | | | | | | | | | | | | |
|----|-------------|-------------|-------------|----------------------|-------------|-----------|---------|---------|----------|---------------|--------------|--------|---------------|-----------|
| R | gpmc_d11 | gpmc_d12 | gpmc_a6 | vdds_mem | | | | | | | | | | |
| T | gpmc_d4 | gpmc_d13 | gpmc_a5 | gpmc_clk | | | | | | | | | | |
| U | vdds_mem | vss | gpmc_nbe1 | NC | | | | | | | | | | |
| V | gpmc_d5 | gpmc_d6 | mcspi2_cs1 | cap_vdd_sram_mpu_iva | | | | | | | | | | |
| W | gpmc_d14 | gpmc_d7 | vss | vdds | | | | | | | | | | |
| Y | gpmc_d15 | mcspi2_simo | mcspi2_somi | mcspi2_cs0 | | | | | | | | | | |
| AA | pop_aa1_aa1 | pop_aa2_aa2 | mcspi2_clk | mcspi1_somi | | | | | | | | | | |
| AB | mcspi1_cs2 | mcspi1_cs3 | mcspi1_clk | mcspi1_simo | | | | | | | | | | |
| AC | mcbsp4_fsx | mcspi1_cs0 | mcspi1_cs1 | vdd_core | | | | | | | | | | |
| AD | mcbsp4_dr | mcbsp4_dx | vdds | vdds | | | | | | | | | | |
| AE | mcbsp4_clkx | mmc2_clk | mmc2_dat7 | mmc2_dat4 | mcbsp3_fsx | mcbsp3_dr | etk_d10 | vdds | vdd_core | etk_ctl | etk_d4 | vss | etk_d3 | sys_boot2 |
| AF | pop_ac8_af1 | pop_u2_af2 | mmc2_dat6 | mmc2_dat3 | mcbsp3_clkx | mcbsp3_dx | etk_d11 | vdds | etk_d8 | etk_clk | etk_d0 | vss | etk_d6 | i2c3_scl |
| AG | pop_ab1_ag1 | vss | vss | mmc2_dat2 | mmc2_cmd | vss | etk_d12 | etk_d14 | etk_d9 | pop_ab8_ag10 | pop_ab9_ag11 | etk_d1 | pop_ab11_ag13 | i2c3_sda |
| AH | pop_ac1_ah1 | pop_ac2_ah2 | mmc2_dat5 | mmc2_dat1 | mmc2_dat0 | vdds_mem | etk_d13 | etk_d15 | etk_d5 | pop_ac13_ah10 | pop_ac9_ah11 | etk_d2 | pop_ac11_ah13 | etk_d7 |
| | 1 | 2 | 3 | 4 | 5 | 6 | 7 | 8 | 9 | 10 | 11 | 12 | 13 | 14 |

Figure 2-8. CBB Pin Map [Quadrant C - Top View]

| | | | | | | | | | | | | | | |
|---------------|---------------|-------------|---------------|-----------|-----------|--------------|--------------|-----------|--------------|---------------|--------------|---------------|---------------|----|
| | | | | | vss | vss | mcbbsp2_dr | | | mmc1_dat7 | vss | mmc1_dat6 | hsusb0_dir | R |
| | | | | | vdd_core | vss | mcbbsp_clks | | | hsusb0_stp | hsusb0_nxt | hsusb0_data0 | hsusb0_clk | T |
| | | | | | vdd_core | vdd_core | mcbbsp1_dr | | | hsusb0_data4 | hsusb0_data3 | hsusb0_data2 | hsusb0_data1 | U |
| | | | | | vss | vdd_core | mcbbsp1_dx | | | vdda_dac | hsusb0_data7 | hsusb0_data6 | hsusb0_data5 | V |
| vdd_mpu_iva | vdds_sram | vss | vdd_core | vss | vdd_core | mcbbsp1_clkx | | | | vss | tv_vref | tv_vfb2 | tv_out2 | W |
| vdd_mpu_iva | vdd_core | vss | vdd_core | vdd_core | vdd_core | mcbbsp1_clkr | | | | vss | vssa_dac | tv_vfb1 | tv_out1 | Y |
| cap_vdd_wkup | vdds_dpll_per | jtag_nrst | jtag_tms_tmsc | jtag_tdo | jtag_tdi | mcbbsp1_fsr | | | | uart2_tx | vss | dss_data15 | dss_data14 | AA |
| | | | | | | | | | | uart2_rts | uart2_cts | dss_data13 | dss_data12 | AB |
| | | | | | | | | | | vss | vss | dss_data22 | dss_data23 | AC |
| | | | | | | | | | | uart2_rx | i2c4_scl | dss_data11 | dss_data10 | AD |
| i2c2_sda | vdds | sys_xtalin | vdd_core | vdd_core | vss | sys_boot5 | sys_clkout2 | vdds | vdd_core | sys_32k | i2c4_sda | vdds | pop_aa23_ae28 | AE |
| i2c2_scl | vdds | sys_xtalout | sys_boot3 | sys_boot4 | vss | sys_boot6 | sys_off_mode | vdds | sys_nreswarm | sys_clkreq | sys_nirq | pop_aa22_af27 | pop_h23_af28 | AF |
| pop_ab13_ag15 | vss | cam_d0 | gpio_114 | gpio_112 | vdds | vdds | dss_data0 | dss_data2 | dss_data4 | sys_clkout1 | sys_boot1 | vdds | pop_ab23_ag28 | AG |
| pop_l1_ah15 | pop_ac14_ah16 | cam_d1 | gpio_115 | gpio_113 | cap_vdd_d | vss | dss_data1 | dss_data3 | dss_data5 | sys_nrespwron | sys_boot0 | pop_ac22_ah27 | pop_ac23_ah28 | AH |
| 15 | 16 | 17 | 18 | 19 | 20 | 21 | 22 | 23 | 24 | 25 | 26 | 27 | 28 | |

Figure 2-9. CBB Pin Map [Quadrant D - Top View]

| | 1 | 2 | 3 | 4 | 5 | 6 | 7 | 8 | 9 | 10 | 11 | 12 | 13 | | | | | | | | |
|---|-----------|---------------|------------|-----------|-----------|------------|-----|-----|------|-----|------|-----|-------------|-------------|-------------|----------------------|-------------|-------------|-------------|-----------|--|
| A | pop_a1_a1 | NC | gpmc_ncs2 | NC | NC | vss | NC | vss | NC | NC | NC | NC | vss | | | | | | | | |
| B | NC | vss | gpmc_wait2 | gpmc_ncs4 | gpmc_ncs6 | gpmc_ncs3 | NC | NC | NC | NC | NC | NC | NC | | | | | | | | |
| C | i2c2_sda | i2c2_scl | sys_boot2 | gpmc_ncs5 | gpmc_ncs7 | gpmc_wait3 | NC | NC | NC | NC | vdds | vss | NC | | | | | | | | |
| D | gpmc_a9 | gpmc_a10 | sys_boot1 | sys_boot6 | NC | NC | vss | NC | vdds | vss | NC | vss | vdd_mpu_iva | | | | | | | | |
| E | gpmc_a7 | gpmc_a8 | sys_boot3 | sys_boot4 | | | | | | | | | | | | | | | | | |
| F | gpmc_a5 | gpmc_a6 | sys_boot0 | NC | | | | | | | | | | | | | | | | | |
| G | vss | gpmc_a4 | sys_boot5 | vdds | | | | | | | | | | NC | vss | vdd_mpu_iva | vss | vdd_core | vdd_mpu_iva | NC | |
| H | gpmc_a2 | gpmc_a3 | uart1_rx | vss | | | | | | | | | | vdd_mpu_iva | NC | NC | NC | NC | NC | NC | |
| J | gpmc_nbe1 | gpmc_a1 | NC | NC | | | | | | | | | | NC | NC | NC | NC | NC | NC | NC | |
| K | vss | gpmc_nbe0_cle | mmc2_dat7 | NC | | | | | | | | | | NC | NC | NC | NC | vdd_mpu_iva | NC | vdds_dpll | |
| L | pop_j1_l1 | gpmc_d14 | mmc2_dat6 | uart1_tx | | | | | | | | | | vdds | NC | vdd_mpu_iva | vss | | | | |
| M | gpmc_nwe | gpmc_d15 | mmc2_dat5 | vdds | | | | | | | | | | vdd_core | NC | vdd_mpu_iva | vdd_mpu_iva | | | | |
| N | gpmc_clk | gpmc_noe | mcbsp3_dr | vss | | | | | | | | | | vdd_mpu_iva | vdd_mpu_iva | cap_vdd_sram_mpu_iva | vss | | | | |

A. Top Views are provided to assist in hardware debugging efforts.

Figure 2-10. CBC Pin Map [Quadrant A - Top View]

| | 14 | 15 | 16 | 17 | 18 | 19 | 20 | 21 | 22 | 23 | 24 | 25 | 26 | | | | | | | | | |
|---|--------------|----------|----|----|-----------|-----------|-------------------|-----------|----|-----------|------------|-------------|-------------|------------|----|----------|--|----------------|---------------|------------|------------|--|
| A | NC | NC | NC | NC | vdds | NC | pop_b16_a20 | NC | NC | cam_wen | cam_d2 | pop_a20_a25 | pop_a21_a26 | | | | | | | | | |
| B | NC | NC | NC | NC | NC | NC | NC | NC | NC | cam_fid | cam_d3 | vss | pop_b21_b26 | | | | | | | | | |
| C | NC | NC | NC | NC | NC | NC | NC | NC | NC | cam_hs | cam_d5 | cam_xclka | cam_pclk | | | | | | | | | |
| D | vss | vdd_core | NC | NC | vss | NC | vss | NC | NC | cam_vs | cam_d4 | cam_d10 | cam_strobe | | | | | | | | | |
| E | | | | | | | | | | vss | NC | vdds | cam_xclkb | cam_d11 | | | | | | | | |
| F | | | | | | | | | | | | | | | | | | uart3_cts_rctx | uart3_rts_sd | dss_data20 | dss_acbias | |
| G | | | | | | | | | | NC | NC | NC | NC | vdd_core | NC | vss | | vss | uart3_tx_irtx | dss_pclk | dss_data6 | |
| H | | | | | | | | | | NC | NC | NC | NC | NC | NC | vdd_core | | NC | uart3_rx_irrx | dss_data7 | dss_data8 | |
| J | NC | vdds | NC | NC | vdds | NC | NC | | | hdq_sio | i2c1_sda | i2c1_scl | dss_data9 | | | | | | | | | |
| K | cap_vdd_wkup | vss | NC | NC | mmc1_dat2 | NC | cap_vdd_sram_core | | | NC | dss_hsync | vss | pop_h21_k26 | | | | | | | | | |
| L | | | | | vss | mmc1_cmd | vss | vdds | | | vss | vdds | dss_data16 | dss_data17 | | | | | | | | |
| M | | | | | vdd_core | mmc1_dat1 | mmc1_dat0 | mmc1_dat4 | | NC | dss_data18 | dss_vsycn | dss_data19 | | | | | | | | | |
| N | | | | | vss | NC | mmc1_clk | mmc1_dat3 | | vdds_mmc1 | dss_data21 | cam_d8 | cam_d9 | | | | | | | | | |

Figure 2-11. CBC Pin Map [Quadrant B - Top View]

| | | | | | | | | | | | | | | | | | |
|----|-------------|------------|--------------|------------|-------------|----------|-------------|-------------|-------------|---------------|-------------|---------------|---------------|--------------|--|--|--|
| | | | | | | | | | | | | | | | | | |
| P | gpmc_d13 | NC | mcbbsp3_dx | NC | | | | mcspi1_somi | mcspi1_simo | mcspi1_clk | vdd_mpu_iva | | | | | | |
| R | vss | uart1_rts | mcbbsp4_dx | vss | | | | mcspi1_cs0 | mcspi1_cs1 | mcspi1_cs2 | mmc2_cmd | | | | | | |
| T | gpmc_d10 | pop_n2_t2 | mcbbsp4_fsx | vdds | | | | vdd_core | mcspi1_cs3 | mmc2_dat1 | mmc2_dat0 | | | | | | |
| U | gpmc_d12 | gpmc_d11 | mcbbsp3_clkx | mcbbsp4_dr | | | | vdd_mpu_iva | mcspi2_somi | mmc2_dat3 | mmc2_dat2 | vdd_mpu_iva | vdds_sram | vdd_mpu_iva | | | |
| V | gpmc_d8 | etk_d9 | mcbbsp4_clkx | NC | | | | vdd_mpu_iva | mcspi2_cs0 | mcspi2_cs1 | mmc2_dat4 | vdd_mpu_iva | sys_off_mode | sys_nreswron | | | |
| W | vss | uart1_cts | mcbbsp3_fsx | vss | | | | mcspi2_clk | mcspi2_simo | vdd_mpu_iva | mmc2_clk | sys_clkout2 | NC | jtag_rtk | | | |
| Y | gpmc_d9 | pop_t2_y2 | etk_d4 | vdds | | | | vss | vdd_core | vdd_mpu_iva | vss | vdd_mpu_iva | vdd_core | jtag_tdo | | | |
| AA | gpmc_d1 | gpmc_d0 | etk_d3 | etk_d8 | | | | | | | | | | | | | |
| AB | etk_d5 | etk_clk | etk_ctl | i2c3_scl | vss | | | | | | | | | | | | |
| AC | gpmc_d3 | gpmc_d2 | etk_d0 | i2c3_sda | gpmc_d7 | gpmc_nwp | vdds | gpmc_wait1 | NC | vss | gpmc_wait0 | NC | NC | | | | |
| AD | gpmc_ncs1 | etk_d7 | etk_d2 | etk_d1 | gpmc_d6 | gpmc_d5 | sys_nreswrm | gpmc_ncs0 | NC | gpmc_nadv_ale | NC | NC | NC | | | | |
| AE | NC | pop_w2_ae2 | etk_d6 | etk_d10 | gpmc_d4 | etk_d12 | vss | NC | etk_d15 | vdds | NC | NC | NC | | | | |
| AF | pop_aa1_af1 | NC | NC | pop_y2_af4 | pop_aa6_af5 | etk_d11 | etk_d13 | pop_y7_af8 | etk_d14 | pop_y9_af10 | NC | pop_aa10_af12 | pop_aa11_af13 | | | | |
| | 1 | 2 | 3 | 4 | 5 | 6 | 7 | 8 | 9 | 10 | 11 | 12 | 13 | | | | |

Figure 2-12. CBC Pin Map [Quadrant C - Top View]

| | | | | | | | | | | | | | | | |
|---------------|---------------|---------------|--------------|---------------|--------------|--------------|--------------|---------------|-----------|--------------|---------------|---------------|------------|-------------|---|
| | | | | | | | | | | | vdds_mmc1a | NC | cam_d6 | cam_d7 | P |
| | | | vss | mcbbsp2_clkx | mcbbsp2_dx | vdd_core | | | | | NC | NC | NC | NC | R |
| | | | mcbbsp1_clkx | mcbbsp2_dr | mcbbsp_clks | mcbbsp1_dr | | | | | vss | vdds | NC | NC | T |
| vdds_dpll_per | jtag_ntrst | jtag_tdi | mcbbsp1_dx | mcbbsp2_fsx | mcbbsp1_clkr | hsusb0_stp | | | | | NC | tv_vfb2 | vss | pop_p21_u26 | U |
| jtag_tck | jtag_tms_tmsc | sys_nirq | mcbbsp1_fsr | hsusb0_data2 | hsusb0_dir | hsusb0_data0 | | | | | tv_vref | vssa_dac | vdda_dac | tv_out2 | V |
| vdds_wkup_bg | sys_clkreq | i2c4_sda | hsusb0_data4 | hsusb0_nxt | hsusb0_clk | hsusb0_data3 | | | | | vss | vdds | tv_vfb1 | tv_out1 | W |
| jtag_emu1 | jtag_emu0 | vss | hsusb0_data7 | hsusb0_data5 | hsusb0_data6 | hsusb0_data1 | | | | | NC | uart2_cts | dss_data13 | vss | Y |
| | | | | | | | | | NC | uart2_rts | dss_data12 | dss_data14 | AA | | |
| | | | | | | | | | vss | NC | vdds | dss_data23 | dss_data15 | AB | |
| NC | vdds | vss | NC | vdds | vss | NC | vdd_core | NC | NC | vdds | dss_data22 | dss_data10 | AC | | |
| vss | i2c4_scl | gpio_113 | gpio_112 | vdds | vdds | vdds | uart2_rx | uart2_tx | dss_data4 | dss_data5 | vss | dss_data11 | AD | | |
| sys_clkout1 | cam_d1 | cam_d0 | gpio_115 | gpio_114 | cap_vdd_d | sys_32k | dss_data0 | dss_data1 | dss_data2 | dss_data3 | pop_y20_ae25 | pop_y21_ae26 | AE | | |
| pop_aa12_af14 | pop_aa13_af15 | pop_aa14_af16 | pop_y14_af17 | pop_aa17_af18 | sys_xtalin | sys_xtalout | pop_y17_af21 | pop_aa19_af22 | vss | pop_y19_af24 | pop_aa20_af25 | pop_aa21_af26 | AF | | |
| 14 | 15 | 16 | 17 | 18 | 19 | 20 | 21 | 22 | 23 | 24 | 25 | 26 | | | |

Figure 2-13. CBC Pin Map [Quadrant D - Top View]

| | 1 | 2 | 3 | 4 | 5 | 6 | 7 | 8 | 9 | 10 | 11 | 12 |
|---|---------------|------------|-----------|------------|---------------|-------------|-------------|-------------|-------------|-------------|-------------|-------------|
| A | NC | NC | | sdr_c_a0 | sdr_c_dqs0 | | sdr_c_dm2 | sdr_c_dqs2 | | sdr_c_clk | sdr_c_nclk | |
| B | NC | sdr_c_a4 | sdr_c_a3 | sdr_c_a1 | sdr_c_d3 | sdr_c_dm0 | sdr_c_d7 | sdr_c_d18 | sdr_c_d19 | sdr_c_d21 | sdr_c_d8 | sdr_c_d10 |
| C | gpmc_wait0 | gpmc_wait3 | sdr_c_a5 | | sdr_c_d1 | sdr_c_d2 | sdr_c_d6 | | sdr_c_d16 | sdr_c_d20 | | sdr_c_d9 |
| D | | gpmc_ncs3 | | | | sdr_c_a2 | sdr_c_d0 | | sdr_c_d4 | sdr_c_d5 | | sdr_c_d22 |
| E | gpmc_nwp | gpmc_ncs0 | sdr_c_a6 | | | | sdr_c_a10 | | sdr_c_a9 | sdr_c_a8 | | sdr_c_d17 |
| F | gpmc_nadv_ale | gpmc_noe | gpmc_ncs6 | gpmc_ncs4 | | sdr_c_a7 | sdr_c_a13 | | sdr_c_a14 | vdd_mpu_iva | | vdd_core |
| G | | gpmc_a10 | gpmc_nwe | gpmc_ncs7 | gpmc_ncs5 | sdr_c_a11 | sdr_c_a12 | | vdd_mpu_iva | vdd_mpu_iva | | vdd_core |
| H | gpmc_a8 | gpmc_a9 | | | | | | vdd_mmc1a | vdd_mpu_iva | vdd_mpu_iva | vss | vdd_core |
| J | gpmc_a7 | gpmc_a6 | gpmc_a5 | gpmc_a4 | | vdds_mem | vdds_mem | vdds_mem | vdd_mpu_iva | vdd_mpu_iva | vss | vss |
| K | | gpmc_a3 | gpmc_a2 | gpmc_a1 | gpmc_nbe0_cle | vdds_mem | vdds_mem | vdds_mem | | vss | vss | |
| L | gpmc_nbe1 | gpmc_d0 | | | | | | vss | | vss | vdd_mpu_iva | vdd_mpu_iva |
| M | gpmc_d1 | gpmc_d2 | gpmc_d4 | mcspi2_cs1 | mcspi2_cs0 | vdd_mpu_iva | vdd_mpu_iva | vdd_mpu_iva | vss | vss | vss | vdd_mpu_iva |

A. Top Views are provided to assist in hardware debugging efforts.

Figure 2-14. CUS Pin Map [Quadrant A - Top View]

| | 13 | 14 | 15 | 16 | 17 | 18 | 19 | 20 | 21 | 22 | 23 | 24 | |
|--|------------|-----------|-----------|-----------|-------------------|---------------|------------|------------|------------|------------|----------------|---------------|---|
| | sdrdc_dqs1 | sdrdc_d14 | | sdrdc_dm3 | sdrdc_dqs3 | | sdrdc_ncs0 | sdrdc_nwe | | cam_hs | uart3_cts_rctx | hdq_sio | A |
| | sdrdc_dm1 | sdrdc_d13 | sdrdc_d15 | sdrdc_d27 | sdrdc_d30 | sdrdc_d31 | sdrdc_ncs1 | sdrdc_cke0 | cam_d5 | cam_xclka | uart3_rts_sd | uart3_rx_irrx | B |
| | sdrdc_d12 | | sdrdc_d26 | sdrdc_d28 | | sdrdc_ba0 | sdrdc_ncas | sdrdc_cke1 | | cam_xclkb | uart3_tx_irtx | | C |
| | sdrdc_d11 | | sdrdc_d25 | sdrdc_d29 | | sdrdc_ba1 | sdrdc_nras | | | | dss_data20 | dss_data6 | D |
| | sdrdc_d23 | | sdrdc_d24 | vdds_mem | | cam_vs | | | | dss_hsync | dss_data7 | dss_data8 | E |
| | vdd_core | | vdds_mem | vdds_mem | | cam_wen | cam_d3 | | cam_d10 | dss_vsync | dss_data9 | | F |
| | vdd_core | | vdds_mem | vdds_mem | | vdds_dpll_dll | cam_d2 | cam_d4 | cam_d11 | dss_pclk | dss_data17 | dss_data18 | G |
| | vdd_core | vss | vdds_mem | vss | cap_vdd_sram_core | | | | | | dss_data19 | cam_fld | H |
| | vss | vss | vss | vss | vdd_core | vdd_core | cam_pclk | cam_strobe | dss_acbias | dss_data16 | cam_d8 | | J |
| | | vss | vss | | vdd_core | vdd_core | vdd_core | i2c1_scl | i2c1_sda | dss_data21 | cam_d9 | cam_d7 | K |
| | vss | vdd_core | vdd_core | | vss | | | | | | mmc1_cmd | cam_d6 | L |
| | vss | vdd_core | vdd_core | vss | vdds | vdds | vdds | mmc1_dat2 | mmc1_dat1 | mmc1_dat0 | mmc1_clk | | M |

Figure 2-15. CUS Pin Map [Quadrant B - Top View]

| | | | | | | | | | | | | | |
|----|-----------|-------------|-------------|--------------|-------------|-------------|-------------|----------------------|---------------|---------------|---------|--------------|--|
| | | | | | | | | | | | | | |
| N | gpmc_d3 | mcspi2_somi | mcspi2_somo | mcspi2_clk | vdd_mpu_iva | vdd_mpu_iva | vdd_mpu_iva | vss | vss | vss | vss | | |
| P | gpmc_d5 | gpmc_d6 | | | | | vss | | vss | vss | vss | | |
| R | gpmc_d7 | gpmc_d8 | gpmc_d11 | mcspi1_simo | mcspi1_cs3 | vdd_mpu_iva | vdd_mpu_iva | vdd_mpu_iva | | vss | vss | | |
| T | | gpmc_d9 | gpmc_d12 | mcspi1_somi | mcspi1_clk | mcspi1_cs0 | vdd_mpu_iva | vdd_mpu_iva | vss | vss | vss | vss | |
| U | gpmc_d10 | gpmc_d13 | | | | | | cap_vdd_sram_mpu_iva | vss | vdds | vss | vdd_mpu_iva | |
| V | gpmc_d14 | gpmc_d15 | mmc2_dat3 | mcbbsp3_fsx | mcbbsp3_dr | mcbbsp3_dx | uart1_rx | | vdds | vdds | | vdd_mpu_iva | |
| W | | gpmc_clk | mmc2_dat2 | mcbbsp3_clkx | | uart1_rts | uart1_tx | | vdds | vdds | | vdd_mpu_iva | |
| Y | mmc2_clk | mmc2_dat6 | mmc2_dat1 | | | | sys_clkout1 | | vdds | sys_nreswarm | | cap_vdd_wkup | |
| AA | mmc2_dat7 | mmc2_dat5 | | | | sys_clkout2 | jtag_rtck | | jtag_tms_tmsc | sys_nrespwron | | vdds_sram | |
| AB | | mmc2_dat4 | mmc2_dat0 | | mmc2_cmd | jtag_tck | jtag_nrst | | jtag_tdo | jtag_tdi | | sys_boot0 | |
| AC | etk_clk | uart1_cts | etk_d10 | etk_d8 | etk_d4 | etk_d1 | etk_d2 | etk_d6 | etk_d11 | etk_d12 | etk_d14 | i2c3_sda | |
| AD | NC | etk_d5 | etk_ctl | | etk_d9 | etk_d0 | | etk_d3 | etk_d7 | | etk_d13 | etk_d15 | |
| | 1 | 2 | 3 | 4 | 5 | 6 | 7 | 8 | 9 | 10 | 11 | 12 | |

Figure 2-16. CUS Pin Map [Quadrant C - Top View]



| | | | | | | | | | | | | |
|--------------|-------------|------------|-----------|---------------|-------------|--------------|------------|-------------|--------------|--------------|--------------|----|
| vss | vss | vss | vss | vdds | vdds | vdds | mmc1_dat6 | mmc1_dat5 | mmc1_dat4 | mmc1_dat3 | vdds_mmc1 | N |
| vss | vss | vss | | vss | | | | | | hsusb0_dir | mmc1_dat7 | P |
| | vss | vss | | vdd_core | vdd_core | vdd_core | mcbsp2_dx | hsusb0_clk | hsusb0_nxt | hsusb0_stp | | R |
| vss | vss | vss | vss | vdd_core | vdd_core | vdd_core | vdd_core | mcbsp2_clkx | hsusb0_data7 | hsusb0_data1 | hsusb0_data0 | T |
| vdd_mpu_iva | vss | vss | vss | vdds_dpll_per | | | | | | hsusb0_data3 | hsusb0_data2 | U |
| vdd_mpu_iva | | vss | vss | | mcbsp1_clkx | mcbsp2_dr | mcbsp2_fsx | dss_data22 | dss_data15 | hsusb0_data5 | | V |
| vdd_mpu_iva | | vss | sys_nirq | | mcbsp1_dx | mcbsp1_clkcr | | dss_data23 | dss_data14 | hsusb0_data6 | hsusb0_data4 | W |
| sys_clkreq | | i2c4_sda | i2c4_scl | | mcbsp1_dr | | | dss_data13 | tv_vfb2 | tv_vref | | Y |
| vdds_wkup_bg | | sys_boot6 | sys_32k | | mcbsp_clks | mcbsp1_fsx | | | | tv_out2 | | AA |
| vdda_dac | | vssa_dac | sys_boot5 | | cam_d0 | dss_data1 | mcbsp1_fsr | | dss_data12 | tv_vfb1 | tv_out1 | AB |
| i2c3_scl | i2c2_sda | i2c2_scl | sys_boot1 | sys_boot4 | cam_d1 | dss_data0 | dss_data3 | dss_data5 | dss_data10 | dss_data11 | jtag_emu0 | AC |
| | sys_xtalout | sys_xtalin | | sys_boot2 | sys_boot3 | | dss_data2 | dss_data4 | | sys_off_mode | jtag_emu1 | AD |
| 13 | 14 | 15 | 16 | 17 | 18 | 19 | 20 | 21 | 22 | 23 | 24 | |

Figure 2-17. CUS Pin Map [Quadrant D - Top View]

2.3 Ball Characteristics

through describe the terminal characteristics and the signals multiplexed on each pin for the CBB, CBC, and CUS packages, respectively. The following list describes the table column headers.

1. **BALL BOTTOM:** Ball number(s) on the bottom side associated with each signal(s) on the bottom.
2. **BALL TOP:** Ball number(s) on the top side associated with each signal(s) on the top.
3. **PIN NAME:** Names of signals multiplexed on each ball (also notice that the name of the pin is the signal name in mode 0).

Note: through do not take into account subsystem pin multiplexing options. Subsystem pin multiplexing options are described in [Section 2.5, Signal Descriptions](#).
4. **MODE:** Multiplexing mode number.
 - a. Mode 0 is the primary mode; this means that when mode 0 is set, the function mapped on the pin corresponds to the name of the pin. There is always a function mapped on the primary mode. Notice that primary mode is not necessarily the default mode.

Note: The default mode is the mode which is automatically configured on release of the internal GLOBAL_PWRON reset; also see the RESET REL. MODE column.
 - b. Modes 1 to 7 are possible modes for alternate functions. On each pin, some modes are effectively used for alternate functions, while some modes are not used and do not correspond to a functional configuration.
5. **TYPE:** Signal direction
 - I = Input
 - O = Output
 - I/O = Input/Output
 - D = Open drain
 - DS = Differential
 - A = Analog

Note: In the safe_mode, the buffer is configured in high-impedance.
6. **BALL RESET STATE:** The state of the terminal at reset (power up).
 - 0: The buffer drives V_{OL} (pulldown/pullup resistor not activated)
0(PD): The buffer drives V_{OL} with an active pulldown resistor.
 - 1: The buffer drives V_{OH} (pulldown/pullup resistor not activated)
1(PU): The buffer drives V_{OH} with an active pullup resistor.
 - Z: High-impedance
 - L: High-impedance with an active pulldown resistor
 - H : High-impedance with an active pullup resistor
7. **BALL RESET REL. STATE:** The state of the terminal at reset release.
 - 0: The buffer drives V_{OL} (pulldown/pullup resistor not activated)
0(PD): The buffer drives V_{OL} with an active pulldown resistor.
 - 1: The buffer drives V_{OH} (pulldown/pullup resistor not activated)
1(PU): The buffer drives V_{OH} with an active pullup resistor.
 - Z: High-impedance
 - L: High-impedance with an active pulldown resistor
 - H : High-impedance with an active pullup resistor
8. **RESET REL. MODE:** This mode is automatically configured on release of the internal GLOBAL_PWRON reset.
9. **POWER:** The voltage supply that powers the terminal's I/O buffers.
10. **HYS:** Indicates if the input buffer is with hysteresis.
11. **BUFFER STRENGTH:** Drive strength of the associated output buffer.
12. **PULL U/D - TYPE:** Denotes the presence of an internal pullup or pulldown resistor. Pullup and pulldown resistors can be enabled or disabled via software.

Note: The pullup/pulldown drive strength is equal to 100 μ A except for CBB balls P27, P26, R27, and R25 and CUS balls N22, N21, N20, and P24, which the pulldown drive strength is equal to 1.8 k Ω .

13. IO CELL: IO cell information.

Note: Configuring two pins to the same input signal is not supported as it can yield unexpected results. This can be easily prevented with the proper software configuration.

Table 2-1. Ball Characteristics (CBB Pkg.)⁽¹⁾

| BALL BOTTOM [1] | BALL TOP [2] | PIN NAME [3] | MODE [4] | TYPE [5] | BALL RESET STATE [6] | BALL RESET REL. STATE [7] | RESET REL. MODE [8] | POWER [9] | HYS [10] | BUFFER STRENGTH (mA) [11] | PULLUP/DOWN TYPE [12] | IO CELL [13] |
|-----------------|--------------|--------------|----------|----------|----------------------|---------------------------|---------------------|-----------|----------|---------------------------|-----------------------|--------------|
| D6 | J2 | sdr_c_d0 | 0 | IO | L | Z | 0 | vdds_mem | Yes | 4 | PU/ PD | LVC MOS |
| C6 | J1 | sdr_c_d1 | 0 | IO | L | Z | 0 | vdds_mem | Yes | 4 | PU/ PD | LVC MOS |
| B6 | G2 | sdr_c_d2 | 0 | IO | L | Z | 0 | vdds_mem | Yes | 4 | PU/ PD | LVC MOS |
| C8 | G1 | sdr_c_d3 | 0 | IO | L | Z | 0 | vdds_mem | Yes | 4 | PU/ PD | LVC MOS |
| C9 | F2 | sdr_c_d4 | 0 | IO | L | Z | 0 | vdds_mem | Yes | 4 | PU/ PD | LVC MOS |
| A7 | F1 | sdr_c_d5 | 0 | IO | L | Z | 0 | vdds_mem | Yes | 4 | PU/ PD | LVC MOS |
| B9 | D2 | sdr_c_d6 | 0 | IO | L | Z | 0 | vdds_mem | Yes | 4 | PU/ PD | LVC MOS |
| A9 | D1 | sdr_c_d7 | 0 | IO | L | Z | 0 | vdds_mem | Yes | 4 | PU/ PD | LVC MOS |
| C14 | B13 | sdr_c_d8 | 0 | IO | L | Z | 0 | vdds_mem | Yes | 4 | PU/ PD | LVC MOS |
| B14 | A13 | sdr_c_d9 | 0 | IO | L | Z | 0 | vdds_mem | Yes | 4 | PU/ PD | LVC MOS |
| C15 | B14 | sdr_c_d10 | 0 | IO | L | Z | 0 | vdds_mem | Yes | 4 | PU/ PD | LVC MOS |
| B16 | A14 | sdr_c_d11 | 0 | IO | L | Z | 0 | vdds_mem | Yes | 4 | PU/ PD | LVC MOS |
| D17 | B16 | sdr_c_d12 | 0 | IO | L | Z | 0 | vdds_mem | Yes | 4 | PU/ PD | LVC MOS |
| C17 | A16 | sdr_c_d13 | 0 | IO | L | Z | 0 | vdds_mem | Yes | 4 | PU/ PD | LVC MOS |
| B17 | B19 | sdr_c_d14 | 0 | IO | L | Z | 0 | vdds_mem | Yes | 4 | PU/ PD | LVC MOS |
| D18 | A19 | sdr_c_d15 | 0 | IO | L | Z | 0 | vdds_mem | Yes | 4 | PU/ PD | LVC MOS |
| D11 | B3 | sdr_c_d16 | 0 | IO | L | Z | 0 | vdds_mem | Yes | 4 | PU/ PD | LVC MOS |
| B10 | A3 | sdr_c_d17 | 0 | IO | L | Z | 0 | vdds_mem | Yes | 4 | PU/ PD | LVC MOS |
| C11 | B5 | sdr_c_d18 | 0 | IO | L | Z | 0 | vdds_mem | Yes | 4 | PU/ PD | LVC MOS |
| D12 | A5 | sdr_c_d19 | 0 | IO | L | Z | 0 | vdds_mem | Yes | 4 | PU/ PD | LVC MOS |
| C12 | B8 | sdr_c_d20 | 0 | IO | L | Z | 0 | vdds_mem | Yes | 4 | PU/ PD | LVC MOS |
| A11 | A8 | sdr_c_d21 | 0 | IO | L | Z | 0 | vdds_mem | Yes | 4 | PU/ PD | LVC MOS |
| B13 | B9 | sdr_c_d22 | 0 | IO | L | Z | 0 | vdds_mem | Yes | 4 | PU/ PD | LVC MOS |
| D14 | A9 | sdr_c_d23 | 0 | IO | L | Z | 0 | vdds_mem | Yes | 4 | PU/ PD | LVC MOS |
| C18 | B21 | sdr_c_d24 | 0 | IO | L | Z | 0 | vdds_mem | Yes | 4 | PU/ PD | LVC MOS |
| A19 | A21 | sdr_c_d25 | 0 | IO | L | Z | 0 | vdds_mem | Yes | 4 | PU/ PD | LVC MOS |
| B19 | D22 | sdr_c_d26 | 0 | IO | L | Z | 0 | vdds_mem | Yes | 4 | PU/ PD | LVC MOS |
| B20 | D23 | sdr_c_d27 | 0 | IO | L | Z | 0 | vdds_mem | Yes | 4 | PU/ PD | LVC MOS |
| D20 | E22 | sdr_c_d28 | 0 | IO | L | Z | 0 | vdds_mem | Yes | 4 | PU/ PD | LVC MOS |
| A21 | E23 | sdr_c_d29 | 0 | IO | L | Z | 0 | vdds_mem | Yes | 4 | PU/ PD | LVC MOS |
| B21 | G22 | sdr_c_d30 | 0 | IO | L | Z | 0 | vdds_mem | Yes | 4 | PU/ PD | LVC MOS |
| C21 | G23 | sdr_c_d31 | 0 | IO | L | Z | 0 | vdds_mem | Yes | 4 | PU/ PD | LVC MOS |
| H9 | AB21 | sdr_c_ba0 | 0 | O | 0 | 0 | 0 | vdds_mem | No | 4 | NA | LVC MOS |
| H10 | AC21 | sdr_c_ba1 | 0 | O | 0 | 0 | 0 | vdds_mem | No | 4 | NA | LVC MOS |
| A4 | N22 | sdr_c_a0 | 0 | O | 0 | 0 | 0 | vdds_mem | No | 4 | NA | LVC MOS |
| B4 | N23 | sdr_c_a1 | 0 | O | 0 | 0 | 0 | vdds_mem | No | 4 | NA | LVC MOS |
| B3 | P22 | sdr_c_a2 | 0 | O | 0 | 0 | 0 | vdds_mem | No | 4 | NA | LVC MOS |
| C5 | P23 | sdr_c_a3 | 0 | O | 0 | 0 | 0 | vdds_mem | No | 4 | NA | LVC MOS |
| C4 | R22 | sdr_c_a4 | 0 | O | 0 | 0 | 0 | vdds_mem | No | 4 | NA | LVC MOS |
| D5 | R23 | sdr_c_a5 | 0 | O | 0 | 0 | 0 | vdds_mem | No | 4 | NA | LVC MOS |
| C3 | T22 | sdr_c_a6 | 0 | O | 0 | 0 | 0 | vdds_mem | No | 4 | NA | LVC MOS |
| C2 | T23 | sdr_c_a7 | 0 | O | 0 | 0 | 0 | vdds_mem | No | 4 | NA | LVC MOS |
| C1 | U22 | sdr_c_a8 | 0 | O | 0 | 0 | 0 | vdds_mem | No | 4 | NA | LVC MOS |
| D4 | U23 | sdr_c_a9 | 0 | O | 0 | 0 | 0 | vdds_mem | No | 4 | NA | LVC MOS |
| D3 | V22 | sdr_c_a10 | 0 | O | 0 | 0 | 0 | vdds_mem | No | 4 | NA | LVC MOS |
| D2 | V23 | sdr_c_a11 | 0 | O | 0 | 0 | 0 | vdds_mem | No | 4 | NA | LVC MOS |

(1) NA in this table stands for "Not Applicable".

Table 2-1. Ball Characteristics (CBB Pkg.) (continued)

| BALL BOTTOM [1] | BALL TOP [2] | PIN NAME [3] | MODE [4] | TYPE [5] | BALL RESET STATE [6] | BALL RESET REL. STATE [7] | RESET REL. MODE [8] | POWER [9] | HYS [10] | BUFFER STRENGTH (mA) [11] | PULLUP /DOWN TYPE [12] | IO CELL [13] |
|-----------------|--------------|--------------|----------|----------|----------------------|---------------------------|---------------------|-----------|----------|---------------------------|------------------------|--------------|
| D1 | W22 | sdrc_a12 | 0 | O | 0 | 0 | 0 | vdds_mem | No | 4 | NA | LVC MOS |
| E2 | W23 | sdrc_a13 | 0 | O | 0 | 0 | 0 | vdds_mem | No | 4 | NA | LVC MOS |
| E1 | Y22 | sdrc_a14 | 0 | O | 0 | 0 | 0 | vdds_mem | No | 4 | NA | LVC MOS |
| H11 | M22 | sdrc_ncs0 | 0 | O | 1 | 1 | 0 | vdds_mem | No | 4 | NA | LVC MOS |
| H12 | M23 | sdrc_ncs1 | 0 | O | 1 | 1 | 0 | vdds_mem | No | 4 | NA | LVC MOS |
| A13 | A11 | sdrc_clk | 0 | IO | L | 0 | 0 | vdds_mem | Yes | 4 | PU/ PD | LVC MOS |
| A14 | B11 | sdrc_nclk | 0 | O | 1 | 1 | 0 | vdds_mem | No | 4 | NA | LVC MOS |
| H16 | J22 | sdrc_cke0 | 0 | O | H | 1 | 7 | vdds_mem | Yes | 4 | PU/ PD | LVC MOS |
| | | safe_mode | 7 | | | | | | | | | |
| H17 | J23 | sdrc_cke1 | 0 | O | H | 1 | 7 | vdds_mem | Yes | 4 | PU/ PD | LVC MOS |
| | | safe_mode | 7 | | | | | | | | | |
| H14 | L23 | sdrc_nras | 0 | O | 1 | 1 | 0 | vdds_mem | No | 4 | NA | LVC MOS |
| H13 | L22 | sdrc_ncas | 0 | O | 1 | 1 | 0 | vdds_mem | No | 4 | NA | LVC MOS |
| H15 | K23 | sdrc_nwe | 0 | O | 1 | 1 | 0 | vdds_mem | No | 4 | NA | LVC MOS |
| B7 | C1 | sdrc_dm0 | 0 | O | 0 | 0 | 0 | vdds_mem | No | 4 | NA | LVC MOS |
| A16 | A17 | sdrc_dm1 | 0 | O | 0 | 0 | 0 | vdds_mem | No | 4 | NA | LVC MOS |
| B11 | A6 | sdrc_dm2 | 0 | O | 0 | 0 | 0 | vdds_mem | No | 4 | NA | LVC MOS |
| C20 | A20 | sdrc_dm3 | 0 | O | 0 | 0 | 0 | vdds_mem | No | 4 | NA | LVC MOS |
| A6 | C2 | sdrc_dqs0 | 0 | IO | L | Z | 0 | vdds_mem | Yes | 4 | PU/ PD | LVC MOS |
| A17 | B17 | sdrc_dqs1 | 0 | IO | L | Z | 0 | vdds_mem | Yes | 4 | PU/ PD | LVC MOS |
| A10 | B6 | sdrc_dqs2 | 0 | IO | L | Z | 0 | vdds_mem | Yes | 4 | PU/ PD | LVC MOS |
| A20 | B20 | sdrc_dqs3 | 0 | IO | L | Z | 0 | vdds_mem | Yes | 4 | PU/ PD | LVC MOS |
| N4 | AC15 | gpmc_a1 | 0 | O | L | L | 7 | vdds_mem | Yes | 4 | PU/ PD | LVC MOS |
| | | gpio_34 | 4 | IO | | | | | | | | |
| | | safe_mode | 7 | | | | | | | | | |
| M4 | AB15 | gpmc_a2 | 0 | O | L | L | 7 | vdds_mem | Yes | 4 | PU/ PD | LVC MOS |
| | | gpio_35 | 4 | IO | | | | | | | | |
| | | safe_mode | 7 | | | | | | | | | |
| L4 | AC16 | gpmc_a3 | 0 | O | L | L | 7 | vdds_mem | Yes | 4 | PU/ PD | LVC MOS |
| | | gpio_36 | 4 | IO | | | | | | | | |
| | | safe_mode | 7 | | | | | | | | | |
| K4 | AB16 | gpmc_a4 | 0 | O | L | L | 7 | vdds_mem | Yes | 4 | PU/ PD | LVC MOS |
| | | gpio_37 | 4 | IO | | | | | | | | |
| | | safe_mode | 7 | | | | | | | | | |
| T3 | AC17 | gpmc_a5 | 0 | O | L | L | 7 | vdds_mem | Yes | 4 | PU/ PD | LVC MOS |
| | | gpio_38 | 4 | IO | | | | | | | | |
| | | safe_mode | 7 | | | | | | | | | |
| R3 | AB17 | gpmc_a6 | 0 | O | H | H | 7 | vdds_mem | Yes | 4 | PU/ PD | LVC MOS |
| | | gpio_39 | 4 | IO | | | | | | | | |
| | | safe_mode | 7 | | | | | | | | | |
| N3 | AC18 | gpmc_a7 | 0 | O | H | H | 7 | vdds_mem | Yes | 4 | PU/ PD | LVC MOS |
| | | gpio_40 | 4 | IO | | | | | | | | |
| | | safe_mode | 7 | | | | | | | | | |
| M3 | AB18 | gpmc_a8 | 0 | O | H | H | 7 | vdds_mem | Yes | 4 | PU/ PD | LVC MOS |
| | | gpio_41 | 4 | IO | | | | | | | | |
| | | safe_mode | 7 | | | | | | | | | |
| L3 | AC19 | gpmc_a9 | 0 | O | H | H | 7 | vdds_mem | Yes | 4 | PU/ PD | LVC MOS |
| | | sys_ndmareq2 | 1 | I | | | | | | | | |
| | | gpio_42 | 4 | IO | | | | | | | | |
| | | safe_mode | 7 | | | | | | | | | |
| K3 | AB19 | gpmc_a10 | 0 | O | H | H | 7 | vdds_mem | Yes | 4 | PU/ PD | LVC MOS |
| | | sys_ndmareq3 | 1 | I | | | | | | | | |
| | | gpio_43 | 4 | IO | | | | | | | | |
| | | | | | | | | | | | | |

Table 2-1. Ball Characteristics (CBB Pkg.) (continued)

| BALL BOTTOM [1] | BALL TOP [2] | PIN NAME [3] | MODE [4] | TYPE [5] | BALL RESET STATE [6] | BALL RESET REL. STATE [7] | RESET REL. MODE [8] | POWER [9] | HYS [10] | BUFFER STRENGTH (mA) [11] | PULLUP /DOWN TYPE [12] | IO CELL [13] |
|-----------------|--------------|--------------|----------|----------|----------------------|---------------------------|---------------------|-----------|----------|---------------------------|------------------------|--------------|
| | | safe_mode | 7 | | | | | | | | | |
| K1 | M2 | gpmc_d0 | 0 | IO | H | H | 0 | vdds_mem | Yes | 4 | PU/ PD | LVC MOS |
| L1 | M1 | gpmc_d1 | 0 | IO | H | H | 0 | vdds_mem | Yes | 4 | PU/ PD | LVC MOS |
| L2 | N2 | gpmc_d2 | 0 | IO | H | H | 0 | vdds_mem | Yes | 4 | PU/ PD | LVC MOS |
| P2 | N1 | gpmc_d3 | 0 | IO | H | H | 0 | vdds_mem | Yes | 4 | PU/ PD | LVC MOS |
| T1 | R2 | gpmc_d4 | 0 | IO | H | H | 0 | vdds_mem | Yes | 4 | PU/ PD | LVC MOS |
| V1 | R1 | gpmc_d5 | 0 | IO | H | H | 0 | vdds_mem | Yes | 4 | PU/ PD | LVC MOS |
| V2 | T2 | gpmc_d6 | 0 | IO | H | H | 0 | vdds_mem | Yes | 4 | PU/ PD | LVC MOS |
| W2 | T1 | gpmc_d7 | 0 | IO | H | H | 0 | vdds_mem | Yes | 4 | PU/ PD | LVC MOS |
| H2 | AB3 | gpmc_d8 | 0 | IO | H | H | 0 | vdds_mem | Yes | 4 | PU/ PD | LVC MOS |
| | | gpio_44 | 4 | IO | | | | | | | | |
| | | safe_mode | 7 | | | | | | | | | |
| K2 | AC3 | gpmc_d9 | 0 | IO | H | H | 0 | vdds_mem | Yes | 4 | PU/ PD | LVC MOS |
| | | gpio_45 | 4 | IO | | | | | | | | |
| | | safe_mode | 7 | | | | | | | | | |
| P1 | AB4 | gpmc_d10 | 0 | IO | H | H | 0 | vdds_mem | Yes | 4 | PU/ PD | LVC MOS |
| | | gpio_46 | 4 | IO | | | | | | | | |
| | | safe_mode | 7 | | | | | | | | | |
| R1 | AC4 | gpmc_d11 | 0 | IO | H | H | 0 | vdds_mem | Yes | 4 | PU/ PD | LVC MOS |
| | | gpio_47 | 4 | IO | | | | | | | | |
| | | safe_mode | 7 | | | | | | | | | |
| R2 | AB6 | gpmc_d12 | 0 | IO | H | H | 0 | vdds_mem | Yes | 4 | PU/ PD | LVC MOS |
| | | gpio_48 | 4 | IO | | | | | | | | |
| | | safe_mode | 7 | | | | | | | | | |
| T2 | AC6 | gpmc_d13 | 0 | IO | H | H | 0 | vdds_mem | Yes | 4 | PU/ PD | LVC MOS |
| | | gpio_49 | 4 | IO | | | | | | | | |
| | | safe_mode | 7 | | | | | | | | | |
| W1 | AB7 | gpmc_d14 | 0 | IO | H | H | 0 | vdds_mem | Yes | 4 | PU/ PD | LVC MOS |
| | | gpio_50 | 4 | IO | | | | | | | | |
| | | safe_mode | 7 | | | | | | | | | |
| Y1 | AC7 | gpmc_d15 | 0 | IO | H | H | 0 | vdds_mem | Yes | 4 | PU/ PD | LVC MOS |
| | | gpio_51 | 4 | IO | | | | | | | | |
| | | safe_mode | 7 | | | | | | | | | |
| G4 | Y2 | gpmc_ncs0 | 0 | O | 1 | 1 | 0 | vdds_mem | No | 4 | NA | LVC MOS |
| H3 | Y1 | gpmc_ncs1 | 0 | O | H | 1 | 0 | vdds_mem | Yes | 4 | PU/ PD | LVC MOS |
| | | gpio_52 | 4 | IO | | | | | | | | |
| | | safe_mode | 7 | | | | | | | | | |
| V8 | NA | gpmc_ncs2 | 0 | O | H | H | 7 | vdds_mem | Yes | 4 | PU/ PD | LVC MOS |
| | | gpio_53 | 4 | IO | | | | | | | | |
| | | safe_mode | 7 | | | | | | | | | |
| U8 | NA | gpmc_ncs3 | 0 | O | H | H | 7 | vdds_mem | Yes | 4 | PU/ PD | LVC MOS |
| | | sys_ndmareq0 | 1 | I | | | | | | | | |
| | | gpio_54 | 4 | IO | | | | | | | | |
| | | safe_mode | 7 | | | | | | | | | |
| T8 | NA | gpmc_ncs4 | 0 | O | H | H | 7 | vdds_mem | Yes | 4 | PU/ PD | LVC MOS |
| | | sys_ndmareq1 | 1 | I | | | | | | | | |
| | | mcbasp4_clkx | 2 | IO | | | | | | | | |
| | | gpt9_pwm_evt | 3 | IO | | | | | | | | |
| | | gpio_55 | 4 | IO | | | | | | | | |
| | | safe_mode | 7 | | | | | | | | | |
| R8 | NA | gpmc_ncs5 | 0 | O | H | H | 7 | vdds_mem | Yes | 4 | PU/ PD | LVC MOS |

Table 2-1. Ball Characteristics (CBB Pkg.) (continued)

| BALL BOTTOM [1] | BALL TOP [2] | PIN NAME [3] | MODE [4] | TYPE [5] | BALL RESET STATE [6] | BALL RESET REL. STATE [7] | RESET REL. MODE [8] | POWER [9] | HYS [10] | BUFFER STRENGTH (mA) [11] | PULLUP/DOWN TYPE [12] | IO CELL [13] |
|-----------------|--------------|---------------|----------|----------|----------------------|---------------------------|---------------------|-----------|----------|---------------------------|-----------------------|--------------|
| | | sys_ndmareq2 | 1 | I | | | | | | | | |
| | | mcbasp4_dr | 2 | I | | | | | | | | |
| | | gpt10_pwm_evt | 3 | IO | | | | | | | | |
| | | gpio_56 | 4 | IO | | | | | | | | |
| | | safe_mode | 7 | | | | | | | | | |
| P8 | NA | gpmc_ncs6 | 0 | O | H | H | 7 | vdds_mem | Yes | 4 | PU/ PD | LVC MOS |
| | | sys_ndmareq3 | 1 | I | | | | | | | | |
| | | mcbasp4_dx | 2 | IO | | | | | | | | |
| | | gpt11_pwm_evt | 3 | IO | | | | | | | | |
| | | gpio_57 | 4 | IO | | | | | | | | |
| | | safe_mode | 7 | | | | | | | | | |
| N8 | NA | gpmc_ncs7 | 0 | O | H | H | 7 | vdds_mem | Yes | 4 | PU/ PD | LVC MOS |
| | | gpmc_io_dir | 1 | O | | | | | | | | |
| | | mcbasp4_fsx | 2 | IO | | | | | | | | |
| | | gpt8_pwm_evt | 3 | IO | | | | | | | | |
| | | gpio_58 | 4 | IO | | | | | | | | |
| | | safe_mode | 7 | | | | | | | | | |
| T4 | W2 | gpmc_clk | 0 | O | L | 0 | 0 | vdds_mem | Yes | 4 | PU/ PD | LVC MOS |
| | | gpio_59 | 4 | IO | | | | | | | | |
| | | safe_mode | 7 | | | | | | | | | |
| F3 | W1 | gpmc_nadv_ale | 0 | O | 0 | 0 | 0 | vdds_mem | No | 4 | NA | LVC MOS |
| G2 | V2 | gpmc_noe | 0 | O | 1 | 1 | 0 | vdds_mem | No | 4 | NA | LVC MOS |
| F4 | V1 | gpmc_nwe | 0 | O | 1 | 1 | 0 | vdds_mem | No | 4 | NA | LVC MOS |
| G3 | AC12 | gpmc_nbe0_cle | 0 | O | L | 0 | 0 | vdds_mem | Yes | 4 | PU/ PD | LVC MOS |
| | | gpio_60 | 4 | IO | | | | | | | | |
| | | safe_mode | 7 | | | | | | | | | |
| U3 | NA | gpmc_nbe1 | 0 | O | L | L | 7 | vdds_mem | Yes | 4 | PU/ PD | LVC MOS |
| | | gpio_61 | 4 | IO | | | | | | | | |
| | | safe_mode | 7 | | | | | | | | | |
| H1 | AB10 | gpmc_nwp | 0 | O | L | 0 | 0 | vdds_mem | Yes | 4 | PU/ PD | LVC MOS |
| | | gpio_62 | 4 | IO | | | | | | | | |
| | | safe_mode | 7 | | | | | | | | | |
| M8 | AB12 | gpmc_wait0 | 0 | I | H | H | 0 | vdds_mem | Yes | NA | PU/ PD | LVC MOS |
| L8 | AC10 | gpmc_wait1 | 0 | I | H | H | 7 | vdds_mem | Yes | 4 | PU/ PD | LVC MOS |
| | | gpio_63 | 4 | IO | | | | | | | | |
| | | safe_mode | 7 | | | | | | | | | |
| K8 | NA | gpmc_wait2 | 0 | I | H | H | 7 | vdds_mem | Yes | 4 | PU/ PD | LVC MOS |
| | | gpio_64 | 4 | IO | | | | | | | | |
| | | safe_mode | 7 | | | | | | | | | |
| J8 | NA | gpmc_wait3 | 0 | I | H | H | 7 | vdds_mem | Yes | 4 | PU/ PD | LVC MOS |
| | | sys_ndmareq1 | 1 | I | | | | | | | | |
| | | gpio_65 | 4 | IO | | | | | | | | |
| | | safe_mode | 7 | | | | | | | | | |
| D28 | NA | dss_pclk | 0 | O | H | H | 7 | vdds | Yes | 8 | PU/ PD | LVC MOS |
| | | gpio_66 | 4 | IO | | | | | | | | |
| | | safe_mode | 7 | | | | | | | | | |
| D26 | NA | dss_hsync | 0 | O | H | H | 7 | vdds | Yes | 8 | PU/ PD | LVC MOS |
| | | gpio_67 | 4 | IO | | | | | | | | |
| | | safe_mode | 7 | | | | | | | | | |

Table 2-1. Ball Characteristics (CBB Pkg.) (continued)

| BALL BOTTOM [1] | BALL TOP [2] | PIN NAME [3] | MODE [4] | TYPE [5] | BALL RESET STATE [6] | BALL RESET REL. STATE [7] | RESET REL. MODE [8] | POWER [9] | HYS [10] | BUFFER STRENGTH (mA) [11] | PULLUP /DOWN TYPE [12] | IO CELL [13] |
|-----------------|--------------|---------------|----------|----------|----------------------|---------------------------|---------------------|-----------|----------|---------------------------|------------------------|--------------|
| D27 | NA | dss_vsync | 0 | O | H | H | 7 | vdds | Yes | 8 | PU/ PD | LVCMOS |
| | | gpio_68 | 4 | IO | | | | | | | | |
| | | safe_mode | 7 | | | | | | | | | |
| E27 | NA | dss_acbias | 0 | O | L | L | 7 | vdds | Yes | 8 | PU/ PD | LVCMOS |
| | | gpio_69 | 4 | IO | | | | | | | | |
| | | safe_mode | 7 | | | | | | | | | |
| AG22 | NA | dss_data0 | 0 | IO | L | L | 7 | vdds | Yes | 8 | PU/ PD | LVCMOS |
| | | uart1_cts | 2 | I | | | | | | | | |
| | | gpio_70 | 4 | IO | | | | | | | | |
| | | safe_mode | 7 | | | | | | | | | |
| AH22 | NA | dss_data1 | 0 | IO | L | L | 7 | vdds | Yes | 8 | PU/ PD | LVCMOS |
| | | uart1_rts | 2 | O | | | | | | | | |
| | | gpio_71 | 4 | IO | | | | | | | | |
| | | safe_mode | 7 | | | | | | | | | |
| AG23 | NA | dss_data2 | 0 | IO | L | L | 7 | vdds | Yes | 8 | PU/ PD | LVCMOS |
| | | gpio_72 | 4 | IO | | | | | | | | |
| | | safe_mode | 7 | | | | | | | | | |
| AH23 | NA | dss_data3 | 0 | IO | L | L | 7 | vdds | Yes | 8 | PU/ PD | LVCMOS |
| | | gpio_73 | 4 | IO | | | | | | | | |
| | | safe_mode | 7 | | | | | | | | | |
| AG24 | NA | dss_data4 | 0 | IO | L | L | 7 | vdds | Yes | 8 | PU/ PD | LVCMOS |
| | | uart3_rx_irrx | 2 | I | | | | | | | | |
| | | gpio_74 | 4 | IO | | | | | | | | |
| | | safe_mode | 7 | | | | | | | | | |
| AH24 | NA | dss_data5 | 0 | IO | L | L | 7 | vdds | Yes | 8 | PU/ PD | LVCMOS |
| | | uart3_tx_irtx | 2 | O | | | | | | | | |
| | | gpio_75 | 4 | IO | | | | | | | | |
| | | safe_mode | 7 | | | | | | | | | |
| E26 | NA | dss_data6 | 0 | IO | L | L | 7 | vdds | Yes | 8 | PU/ PD | LVCMOS |
| | | uart1_tx | 2 | O | | | | | | | | |
| | | gpio_76 | 4 | IO | | | | | | | | |
| | | safe_mode | 7 | | | | | | | | | |
| F28 | NA | dss_data7 | 0 | IO | L | L | 7 | vdds | Yes | 8 | PU/ PD | LVCMOS |
| | | uart1_rx | 2 | I | | | | | | | | |
| | | gpio_77 | 4 | IO | | | | | | | | |
| | | safe_mode | 7 | | | | | | | | | |
| F27 | NA | dss_data8 | 0 | IO | L | L | 7 | vdds | Yes | 8 | PU/ PD | LVCMOS |
| | | gpio_78 | 4 | IO | | | | | | | | |
| | | safe_mode | 7 | | | | | | | | | |
| G26 | NA | dss_data9 | 0 | IO | L | L | 7 | vdds | Yes | 8 | PU/ PD | LVCMOS |
| | | gpio_79 | 4 | IO | | | | | | | | |
| | | safe_mode | 7 | | | | | | | | | |
| AD28 | NA | dss_data10 | 0 | IO | L | L | 7 | vdds | Yes | 8 | PU/ PD | LVCMOS |
| | | gpio_80 | 4 | IO | | | | | | | | |
| | | safe_mode | 7 | | | | | | | | | |
| AD27 | NA | dss_data11 | 0 | IO | L | L | 7 | vdds | Yes | 8 | PU/ PD | LVCMOS |
| | | gpio_81 | 4 | IO | | | | | | | | |
| | | safe_mode | 7 | | | | | | | | | |
| AB28 | NA | dss_data12 | 0 | IO | L | L | 7 | vdds | Yes | 8 | PU/ PD | LVCMOS |
| | | gpio_82 | 4 | IO | | | | | | | | |
| | | safe_mode | 7 | | | | | | | | | |
| AB27 | NA | dss_data13 | 0 | IO | L | L | 7 | vdds | Yes | 8 | PU/ PD | LVCMOS |
| | | gpio_83 | 4 | IO | | | | | | | | |
| | | safe_mode | 7 | | | | | | | | | |

Table 2-1. Ball Characteristics (CBB Pkg.) (continued)

| BALL BOTTOM [1] | BALL TOP [2] | PIN NAME [3] | MODE [4] | TYPE [5] | BALL RESET STATE [6] | BALL RESET REL. STATE [7] | RESET REL. MODE [8] | POWER [9] | HYS [10] | BUFFER STRENGTH TH (mA) [11] | PULLUP /DOWN TYPE [12] | IO CELL [13] |
|-----------------|--------------|--------------|----------|----------|----------------------|---------------------------|---------------------|-----------|----------|------------------------------|------------------------|--------------|
| AA28 | NA | dss_data14 | 0 | IO | L | L | 7 | vdds | Yes | 8 | PU/ PD | LVCMOS |
| | | gpio_84 | 4 | IO | | | | | | | | |
| | | safe_mode | 7 | | | | | | | | | |
| AA27 | NA | dss_data15 | 0 | IO | L | L | 7 | vdds | Yes | 8 | PU/ PD | LVCMOS |
| | | gpio_85 | 4 | IO | | | | | | | | |
| | | safe_mode | 7 | | | | | | | | | |
| G25 | NA | dss_data16 | 0 | IO | L | L | 7 | vdds | Yes | 8 | PU/ PD | LVCMOS |
| | | gpio_86 | 4 | IO | | | | | | | | |
| | | safe_mode | 7 | | | | | | | | | |
| H27 | NA | dss_data17 | 0 | IO | L | L | 7 | vdds | Yes | 8 | PU/ PD | LVCMOS |
| | | gpio_87 | 4 | IO | | | | | | | | |
| | | safe_mode | 7 | | | | | | | | | |
| H26 | NA | dss_data18 | 0 | IO | L | L | 7 | vdds | Yes | 8 | PU/ PD | LVCMOS |
| | | mcspi3_clk | 2 | IO | | | | | | | | |
| | | dss_data0 | 3 | IO | | | | | | | | |
| | | gpio_88 | 4 | IO | | | | | | | | |
| | | safe_mode | 7 | | | | | | | | | |
| H25 | NA | dss_data19 | 0 | IO | L | L | 7 | vdds | Yes | 8 | PU/ PD | LVCMOS |
| | | mcspi3_simo | 2 | IO | | | | | | | | |
| | | dss_data1 | 3 | IO | | | | | | | | |
| | | gpio_89 | 4 | IO | | | | | | | | |
| | | safe_mode | 7 | | | | | | | | | |
| E28 | NA | dss_data20 | 0 | O | H | H | 7 | vdds | Yes | 8 | PU/ PD | LVCMOS |
| | | mcspi3_somi | 2 | IO | | | | | | | | |
| | | dss_data2 | 3 | IO | | | | | | | | |
| | | gpio_90 | 4 | IO | | | | | | | | |
| | | safe_mode | 7 | | | | | | | | | |
| J26 | NA | dss_data21 | 0 | O | L | L | 7 | vdds | Yes | 8 | PU/ PD | LVCMOS |
| | | mcspi3_cs0 | 2 | IO | | | | | | | | |
| | | dss_data3 | 3 | IO | | | | | | | | |
| | | gpio_91 | 4 | IO | | | | | | | | |
| | | safe_mode | 7 | | | | | | | | | |
| AC27 | NA | dss_data22 | 0 | O | L | L | 7 | vdds | Yes | 8 | PU/ PD | LVCMOS |
| | | mcspi3_cs1 | 2 | O | | | | | | | | |
| | | dss_data4 | 3 | IO | | | | | | | | |
| | | gpio_92 | 4 | IO | | | | | | | | |
| | | safe_mode | 7 | | | | | | | | | |
| AC28 | NA | dss_data23 | 0 | O | L | L | 7 | vdds | Yes | 8 | PU/ PD | LVCMOS |
| | | dss_data5 | 3 | IO | | | | | | | | |
| | | gpio_93 | 4 | IO | | | | | | | | |
| | | safe_mode | 7 | | | | | | | | | |
| W28 | NA | tv_out2 | 0 | O | Z | 0 | 0 | vdda_dac | | NA ⁽²⁾ | NA | 10-bit DAC |
| Y28 | NA | tv_out1 | 0 | O | Z | 0 | 0 | vdda_dac | | NA ⁽²⁾ | NA | 10-bit DAC |
| Y27 | NA | tv_vfb1 | 0 | AO | Z | NA | 0 | vdda_dac | | NA ⁽²⁾ | NA | 10-bit DAC |
| W27 | NA | tv_vfb2 | 0 | AO | Z | NA | 0 | vdda_dac | | NA ⁽²⁾ | NA | 10-bit DAC |
| W26 | NA | tv_vref | 0 | AO | Z | NA | 0 | vdda_dac | | NA ⁽²⁾ | NA | 10-bit DAC |
| A24 | NA | cam_hs | 0 | IO | L | L | 7 | vdds | Yes | 4 | PU/ PD | LVCMOS |
| | | gpio_94 | 4 | IO | | | | | | | | |
| | | safe_mode | 7 | | | | | | | | | |
| A23 | NA | cam_vs | 0 | IO | L | L | 7 | vdds | Yes | 4 | PU/ PD | LVCMOS |
| | | gpio_95 | 4 | IO | | | | | | | | |
| | | safe_mode | 7 | | | | | | | | | |

(2) The drive strength is fixed regardless of the load. The driver is designed to drive 75ohm for video applications.

Table 2-1. Ball Characteristics (CBB Pkg.) (continued)

| BALL BOTTOM [1] | BALL TOP [2] | PIN NAME [3] | MODE [4] | TYPE [5] | BALL RESET STATE [6] | BALL RESET REL. STATE [7] | RESET REL. MODE [8] | POWER [9] | HYS [10] | BUFFER STRENGTH TH (mA) [11] | PULLUP /DOWN TYPE [12] | IO CELL [13] |
|-----------------|--------------|-------------------|----------|----------|----------------------|---------------------------|---------------------|-----------|----------|------------------------------|------------------------|--------------|
| C25 | NA | cam_xclka | 0 | O | L | L | 7 | vdds | Yes | 4 | PU/ PD | LVCMOS |
| | | gpio_96 | 4 | IO | | | | | | | | |
| | | safe_mode | 7 | | | | | | | | | |
| C27 | NA | cam_pclk | 0 | I | L | L | 7 | vdds | Yes | 4 | PU/ PD | LVCMOS |
| | | gpio_97 | 4 | IO | | | | | | | | |
| | | safe_mode | 7 | | | | | | | | | |
| C23 | NA | cam_fld | 0 | IO | L | L | 7 | vdds | Yes | 4 | PU/ PD | LVCMOS |
| | | cam_global_r eset | 2 | IO | | | | | | | | |
| | | gpio_98 | 4 | IO | | | | | | | | |
| | | safe_mode | 7 | | | | | | | | | |
| AG17 | NA | cam_d0 | 0 | I | L | L | 7 | vdds | Yes | NA | PU/PD | LVCMOS |
| | | gpio_99 | 4 | I | | | | | | | | |
| | | safe_mode | 7 | | | | | | | | | |
| AH17 | NA | cam_d1 | 0 | I | L | L | 7 | vdds | Yes | NA | PU/PD | LVCMOS |
| | | gpio_100 | 4 | I | | | | | | | | |
| | | safe_mode | 7 | | | | | | | | | |
| B24 | NA | cam_d2 | 0 | I | L | L | 7 | vdds | Yes | 4 | PU/ PD | LVCMOS |
| | | gpio_101 | 4 | IO | | | | | | | | |
| | | safe_mode | 7 | | | | | | | | | |
| C24 | NA | cam_d3 | 0 | I | L | L | 7 | vdds | Yes | 4 | PU/ PD | LVCMOS |
| | | gpio_102 | 4 | IO | | | | | | | | |
| | | safe_mode | 7 | | | | | | | | | |
| D24 | NA | cam_d4 | 0 | I | L | L | 7 | vdds | Yes | 4 | PU/ PD | LVCMOS |
| | | gpio_103 | 4 | IO | | | | | | | | |
| | | safe_mode | 7 | | | | | | | | | |
| A25 | NA | cam_d5 | 0 | I | L | L | 7 | vdds | Yes | 4 | PU/ PD | LVCMOS |
| | | gpio_104 | 4 | IO | | | | | | | | |
| | | safe_mode | 7 | | | | | | | | | |
| K28 | NA | cam_d6 | 0 | I | L | L | 7 | vdds | Yes | NA | PU/PD | LVCMOS |
| | | gpio_105 | 4 | IO | | | | | | 8 | | |
| | | safe_mode | 7 | | | | | | | NA | | |
| L28 | NA | cam_d7 | 0 | I | L | L | 7 | vdds | Yes | NA | PU/PD | LVCMOS |
| | | gpio_106 | 4 | IO | | | | | | 8 | | |
| | | safe_mode | 7 | | | | | | | NA | | |
| K27 | NA | cam_d8 | 0 | I | L | L | 7 | vdds | Yes | NA | PU/PD | LVCMOS |
| | | gpio_107 | 4 | IO | | | | | | 8 | | |
| | | safe_mode | 7 | | | | | | | NA | | |
| L27 | NA | cam_d9 | 0 | I | L | L | 7 | vdds | Yes | NA | PU/PD | LVCMOS |
| | | gpio_108 | 4 | IO | | | | | | 8 | | |
| | | safe_mode | 7 | | | | | | | NA | | |
| B25 | NA | cam_d10 | 0 | I | L | L | 7 | vdds | Yes | 4 | PU/ PD | LVCMOS |
| | | gpio_109 | 4 | IO | | | | | | | | |
| | | safe_mode | 7 | | | | | | | | | |
| C26 | NA | cam_d11 | 0 | I | L | L | 7 | vdds | Yes | 4 | PU/ PD | LVCMOS |
| | | gpio_110 | 4 | IO | | | | | | | | |
| | | safe_mode | 7 | | | | | | | | | |
| B26 | NA | cam_xclkb | 0 | O | L | L | 7 | vdds | Yes | 4 | PU/ PD | LVCMOS |
| | | gpio_111 | 4 | IO | | | | | | | | |
| | | safe_mode | 7 | | | | | | | | | |
| B23 | NA | cam_wen | 0 | I | L | L | 7 | vdds | Yes | 4 | PU/ PD | LVCMOS |
| | | cam_shutter | 2 | O | | | | | | | | |
| | | gpio_167 | 4 | IO | | | | | | | | |
| | | safe_mode | 7 | | | | | | | | | |
| D25 | NA | cam_strobe | 0 | O | L | L | 7 | vdds | Yes | 4 | PU/ PD | LVCMOS |

Table 2-1. Ball Characteristics (CBB Pkg.) (continued)

| BALL BOTTOM [1] | BALL TOP [2] | PIN NAME [3] | MODE [4] | TYPE [5] | BALL RESET STATE [6] | BALL RESET REL. STATE [7] | RESET REL. MODE [8] | POWER [9] | HYS [10] | BUFFER STRENGTH (mA) [11] | PULLUP /DOWN TYPE [12] | IO CELL [13] |
|-----------------|--------------|--------------|----------|----------|----------------------|---------------------------|---------------------|------------|----------|---------------------------|------------------------|--------------|
| | | gpio_126 | 4 | IO | | | | | | | | |
| | | safe_mode | 7 | | | | | | | | | |
| AG19 | NA | gpio_112 | 4 | I | L | L | 7 | vdds | Yes | NA | PU/PD | LVC MOS |
| | | safe_mode | 7 | | | | | | | | | |
| AH19 | NA | gpio_113 | 4 | I | L | L | 7 | vdds | Yes | NA | PU/PD | LVC MOS |
| | | safe_mode | 7 | | | | | | | | | |
| AG18 | NA | gpio_114 | 4 | I | L | L | 7 | vdds | Yes | NA | PU/PD | LVC MOS |
| | | safe_mode | 7 | | | | | | | | | |
| AH18 | NA | gpio_115 | 4 | I | L | L | 7 | vdds | Yes | NA | PU/PD | LVC MOS |
| | | safe_mode | 7 | | | | | | | | | |
| P21 | NA | mcbsp2_fsx | 0 | IO | L | L | 7 | vdds | Yes | 4 ⁽³⁾ | PU/ PD | LVC MOS |
| | | gpio_116 | 4 | IO | | | | | | | | |
| | | safe_mode | 7 | | | | | | | | | |
| N21 | NA | mcbsp2_clkx | 0 | IO | L | L | 7 | vdds | Yes | 4 ⁽³⁾ | PU/ PD | LVC MOS |
| | | gpio_117 | 4 | IO | | | | | | | | |
| | | safe_mode | 7 | | | | | | | | | |
| R21 | NA | mcbsp2_dr | 0 | I | L | L | 7 | vdds | Yes | 4 ⁽³⁾ | PU/ PD | LVC MOS |
| | | gpio_118 | 4 | IO | | | | | | | | |
| | | safe_mode | 7 | | | | | | | | | |
| M21 | NA | mcbsp2_dx | 0 | IO | L | L | 7 | vdds | Yes | 4 ⁽³⁾ | PU/ PD | LVC MOS |
| | | gpio_119 | 4 | IO | | | | | | | | |
| | | safe_mode | 7 | | | | | | | | | |
| N28 | NA | mmc1_clk | 0 | O | L | L | 7 | vdds_mmc1 | Yes | 8 | PU/ PD ⁽⁴⁾ | LVC MOS |
| | | gpio_120 | 4 | IO | | | | | | | | |
| | | safe_mode | 7 | | | | | | | | | |
| M27 | NA | mmc1_cmd | 0 | IO | L | L | 7 | vdds_mmc1 | Yes | 8 | PU/ PD ⁽⁴⁾ | LVC MOS |
| | | gpio_121 | 4 | IO | | | | | | | | |
| | | safe_mode | 7 | | | | | | | | | |
| N27 | NA | mmc1_dat0 | 0 | IO | L | L | 7 | vdds_mmc1 | Yes | 8 | PU/ PD ⁽⁴⁾ | LVC MOS |
| | | gpio_122 | 4 | IO | | | | | | | | |
| | | safe_mode | 7 | | | | | | | | | |
| N26 | NA | mmc1_dat1 | 0 | IO | L | L | 7 | vdds_mmc1 | Yes | 8 | PU/ PD ⁽⁴⁾ | LVC MOS |
| | | gpio_123 | 4 | IO | | | | | | | | |
| | | safe_mode | 7 | | | | | | | | | |
| N25 | NA | mmc1_dat2 | 0 | IO | L | L | 7 | vdds_mmc1 | Yes | 8 | PU/ PD ⁽⁴⁾ | LVC MOS |
| | | gpio_124 | 4 | IO | | | | | | | | |
| | | safe_mode | 7 | | | | | | | | | |
| P28 | NA | mmc1_dat3 | 0 | IO | L | L | 7 | vdds_mmc1 | Yes | 8 | PU/ PD ⁽⁴⁾ | LVC MOS |
| | | gpio_125 | 4 | IO | | | | | | | | |
| | | safe_mode | 7 | | | | | | | | | |
| P27 | NA | mmc1_dat4 | 0 | IO | L | L | 7 | vdds_mmc1a | No | 8 | PD ⁽⁴⁾ | LVC MOS |
| | | gpio_126 | 4 | IO | | | | | | | | |
| | | safe_mode | 7 | | | | | | | | | |
| P26 | NA | mmc1_dat5 | 0 | IO | L | L | 7 | vdds_mmc1a | No | 8 | PD ⁽⁴⁾ | LVC MOS |
| | | gpio_127 | 4 | IO | | | | | | | | |
| | | safe_mode | 7 | | | | | | | | | |
| R27 | NA | mmc1_dat6 | 0 | IO | L | L | 7 | vdds_mmc1a | No | 8 | PD ⁽⁴⁾ | LVC MOS |
| | | gpio_128 | 4 | IO | | | | | | | | |
| | | safe_mode | 7 | | | | | | | | | |
| R25 | NA | mmc1_dat7 | 0 | IO | L | L | 7 | vdds_mmc1a | No | 8 | PD ⁽⁴⁾ | LVC MOS |

(3) The buffer strength of this IO cell is programmable (2, 4, 6, or 8 mA) according to the selected mode; the default value is described in the above table.

(4) The PU nominal drive strength of this IO cell is equal to 25 uA @ 1.8V and 41.6 uA @ 3.0V. The PD nominal drive strength of this IO cell is equal to 1 mA @ 1.8V and 1.66 mA @ 3.0V.

Table 2-1. Ball Characteristics (CBB Pkg.) (continued)

| BALL BOTTOM [1] | BALL TOP [2] | PIN NAME [3] | MODE [4] | TYPE [5] | BALL RESET STATE [6] | BALL RESET REL. STATE [7] | RESET REL. MODE [8] | POWER [9] | HYS [10] | BUFFER STRENGTH (mA) [11] | PULLUP /DOWN TYPE [12] | IO CELL [13] |
|-----------------|--------------|------------------|----------|----------|----------------------|---------------------------|---------------------|-----------|----------|---------------------------|------------------------|--------------|
| | | gpio_129 | 4 | IO | | | | | | | | |
| | | safe_mode | 7 | | | | | | | | | |
| AE2 | NA | mmc2_clk | 0 | O | L | L | 7 | vdds | Yes | 4 | PU/ PD | LVC MOS |
| | | mcs pi3_clk | 1 | IO | | | | | | | | |
| | | gpio_130 | 4 | IO | | | | | | | | |
| | | safe_mode | 7 | | | | | | | | | |
| AG5 | NA | mmc2_cmd | 0 | IO | H | H | 7 | vdds | Yes | 4 | PU/ PD | LVC MOS |
| | | mcs pi3_simo | 1 | IO | | | | | | | | |
| | | gpio_131 | 4 | IO | | | | | | | | |
| | | safe_mode | 7 | | | | | | | | | |
| AH5 | NA | mmc2_dat0 | 0 | IO | H | H | 7 | vdds | Yes | 4 | PU/ PD | LVC MOS |
| | | mcs pi3_somi | 1 | IO | | | | | | | | |
| | | gpio_132 | 4 | IO | | | | | | | | |
| | | safe_mode | 7 | | | | | | | | | |
| AH4 | NA | mmc2_dat1 | 0 | IO | H | H | 7 | vdds | Yes | 4 | PU/ PD | LVC MOS |
| | | gpio_133 | 4 | IO | | | | | | | | |
| | | safe_mode | 7 | | | | | | | | | |
| AG4 | NA | mmc2_dat2 | 0 | IO | H | H | 7 | vdds | Yes | 4 | PU/ PD | LVC MOS |
| | | mcs pi3_cs1 | 1 | O | | | | | | | | |
| | | gpio_134 | 4 | IO | | | | | | | | |
| | | safe_mode | 7 | | | | | | | | | |
| AF4 | NA | mmc2_dat3 | 0 | IO | H | H | 7 | vdds | Yes | 4 | PU/ PD | LVC MOS |
| | | mcs pi3_cs0 | 1 | IO | | | | | | | | |
| | | gpio_135 | 4 | IO | | | | | | | | |
| | | safe_mode | 7 | | | | | | | | | |
| AE4 | NA | mmc2_dat4 | 0 | IO | L | L | 7 | vdds | Yes | 4 | PU/ PD | LVC MOS |
| | | mmc2_dir_dat0 | 1 | O | | | | | | | | |
| | | mmc3_dat0 | 3 | IO | | | | | | | | |
| | | gpio_136 | 4 | IO | | | | | | | | |
| | | safe_mode | 7 | | | | | | | | | |
| AH3 | NA | mmc2_dat5 | 0 | IO | L | L | 7 | vdds | Yes | 4 | PU/ PD | LVC MOS |
| | | mmc2_dir_dat1 | 1 | O | | | | | | | | |
| | | cam_global_reset | 2 | IO | | | | | | | | |
| | | mmc3_dat1 | 3 | IO | | | | | | | | |
| | | gpio_137 | 4 | IO | | | | | | | | |
| | | hsusb3_tll_stp | 5 | IO | | | | | | | | |
| | | mm3_rxdp | 6 | IO | | | | | | | | |
| | | safe_mode | 7 | | | | | | | | | |
| AF3 | NA | mmc2_dat6 | 0 | IO | L | L | 7 | vdds | Yes | 4 | PU/ PD | LVC MOS |
| | | mmc2_dir_cmd | 1 | O | | | | | | | | |
| | | cam_shutter | 2 | O | | | | | | | | |
| | | mmc3_dat2 | 3 | IO | | | | | | | | |
| | | gpio_138 | 4 | IO | | | | | | | | |
| | | hsusb3_tll_dir | 5 | IO | | | | | | | | |
| | | safe_mode | 7 | | | | | | | | | |
| AE3 | NA | mmc2_dat7 | 0 | IO | L | L | 7 | vdds | Yes | 4 | PU/ PD | LVC MOS |
| | | mmc2_clkin | 1 | I | | | | | | | | |
| | | mmc3_dat3 | 3 | IO | | | | | | | | |
| | | gpio_139 | 4 | IO | | | | | | | | |

Table 2-1. Ball Characteristics (CBB Pkg.) (continued)

| BALL BOTTOM [1] | BALL TOP [2] | PIN NAME [3] | MODE [4] | TYPE [5] | BALL RESET STATE [6] | BALL RESET REL. STATE [7] | RESET REL. MODE [8] | POWER [9] | HYS [10] | BUFFER STRENGTH (mA) [11] | PULLUP /DOWN TYPE [12] | IO CELL [13] |
|-----------------|--------------|------------------|----------|----------|----------------------|---------------------------|---------------------|-----------|----------|---------------------------|------------------------|--------------|
| | | hsusb3_tll_nxt | 5 | IO | | | | | | | | |
| | | mm3_rxdm | 6 | IO | | | | | | | | |
| | | safe_mode | 7 | | | | | | | | | |
| AF6 | NA | mcbbsp3_dx | 0 | IO | L | L | 7 | vdds | Yes | 4 | PU/ PD | LVC MOS |
| | | uart2_cts | 1 | I | | | | | | | | |
| | | gpio_140 | 4 | IO | | | | | | | | |
| | | hsusb3_tll_data4 | 5 | IO | | | | | | | | |
| | | safe_mode | 7 | | | | | | | | | |
| AE6 | NA | mcbbsp3_dr | 0 | I | L | L | 7 | vdds | Yes | 4 | PU/ PD | LVC MOS |
| | | uart2_rts | 1 | O | | | | | | | | |
| | | gpio_141 | 4 | IO | | | | | | | | |
| | | hsusb3_tll_data5 | 5 | IO | | | | | | | | |
| | | safe_mode | 7 | | | | | | | | | |
| AF5 | NA | mcbbsp3_clkx | 0 | IO | L | L | 7 | vdds | Yes | 4 | PU/ PD | LVC MOS |
| | | uart2_tx | 1 | O | | | | | | | | |
| | | gpio_142 | 4 | IO | | | | | | | | |
| | | hsusb3_tll_data6 | 5 | IO | | | | | | | | |
| | | safe_mode | 7 | | | | | | | | | |
| AE5 | NA | mcbbsp3_fsx | 0 | IO | L | L | 7 | vdds | Yes | 4 | PU/ PD | LVC MOS |
| | | uart2_rx | 1 | I | | | | | | | | |
| | | gpio_143 | 4 | IO | | | | | | | | |
| | | hsusb3_tll_data7 | 5 | IO | | | | | | | | |
| | | safe_mode | 7 | | | | | | | | | |
| AB26 | NA | uart2_cts | 0 | I | H | H | 7 | vdds | Yes | 4 | PU/ PD | LVC MOS |
| | | mcbbsp3_dx | 1 | IO | | | | | | | | |
| | | gpt9_pwm_evt | 2 | IO | | | | | | | | |
| | | gpio_144 | 4 | IO | | | | | | | | |
| | | safe_mode | 7 | | | | | | | | | |
| AB25 | NA | uart2_rts | 0 | O | H | H | 7 | vdds | Yes | 4 | PU/ PD | LVC MOS |
| | | mcbbsp3_dr | 1 | I | | | | | | | | |
| | | gpt10_pwm_evt | 2 | IO | | | | | | | | |
| | | gpio_145 | 4 | IO | | | | | | | | |
| | | safe_mode | 7 | | | | | | | | | |
| AA25 | NA | uart2_tx | 0 | O | H | H | 7 | vdds | Yes | 4 | PU/ PD | LVC MOS |
| | | mcbbsp3_clkx | 1 | IO | | | | | | | | |
| | | gpt11_pwm_evt | 2 | IO | | | | | | | | |
| | | gpio_146 | 4 | IO | | | | | | | | |
| | | safe_mode | 7 | | | | | | | | | |
| AD25 | NA | uart2_rx | 0 | I | H | H | 7 | vdds | Yes | 4 | PU/ PD | LVC MOS |
| | | mcbbsp3_fsx | 1 | IO | | | | | | | | |
| | | gpt8_pwm_evt | 2 | IO | | | | | | | | |
| | | gpio_147 | 4 | IO | | | | | | | | |
| | | safe_mode | 7 | | | | | | | | | |
| AA8 | NA | uart1_tx | 0 | O | L | L | 7 | vdds | Yes | 4 | PU/ PD | LVC MOS |
| | | gpio_148 | 4 | IO | | | | | | | | |
| | | safe_mode | 7 | | | | | | | | | |
| AA9 | NA | uart1_rts | 0 | O | L | L | 7 | vdds | Yes | 4 | PU/ PD | LVC MOS |

Table 2-1. Ball Characteristics (CBB Pkg.) (continued)

| BALL BOTTOM [1] | BALL TOP [2] | PIN NAME [3] | MODE [4] | TYPE [5] | BALL RESET STATE [6] | BALL RESET REL. STATE [7] | RESET REL. MODE [8] | POWER [9] | HYS [10] | BUFFER STRENGTH (mA) [11] | PULLUP /DOWN TYPE [12] | IO CELL [13] |
|-----------------|--------------|------------------|----------|----------|----------------------|---------------------------|---------------------|-----------|----------|---------------------------|------------------------|--------------|
| | | gpio_149 | 4 | IO | | | | | | | | |
| | | safe_mode | 7 | | | | | | | | | |
| W8 | NA | uart1_cts | 0 | I | L | L | 7 | vdds | Yes | 4 | PU/ PD | LVC MOS |
| | | gpio_150 | 4 | IO | | | | | | | | |
| | | hsusb3_tll_clk | 5 | O | | | | | | | | |
| | | safe_mode | 7 | | | | | | | | | |
| Y8 | NA | uart1_rx | 0 | I | L | L | 7 | vdds | Yes | 4 | PU/ PD | LVC MOS |
| | | mcbasp1_clk | 2 | IO | | | | | | | | |
| | | mcspi4_clk | 3 | IO | | | | | | | | |
| | | gpio_151 | 4 | IO | | | | | | | | |
| | | safe_mode | 7 | | | | | | | | | |
| AE1 | NA | mcbasp4_clkx | 0 | IO | L | L | 7 | vdds | Yes | 4 | PU/ PD | LVC MOS |
| | | gpio_152 | 4 | IO | | | | | | | | |
| | | hsusb3_tll_data1 | 5 | IO | | | | | | | | |
| | | mm3_txse0 | 6 | IO | | | | | | | | |
| | | safe_mode | 7 | | | | | | | | | |
| AD1 | NA | mcbasp4_dr | 0 | I | L | L | 7 | vdds | Yes | 4 | PU/ PD | LVC MOS |
| | | gpio_153 | 4 | IO | | | | | | | | |
| | | hsusb3_tll_data0 | 5 | IO | | | | | | | | |
| | | mm3_rxcv | 6 | IO | | | | | | | | |
| | | safe_mode | 7 | | | | | | | | | |
| AD2 | NA | mcbasp4_dx | 0 | IO | L | L | 7 | vdds | Yes | 4 | PU/ PD | LVC MOS |
| | | gpio_154 | 4 | IO | | | | | | | | |
| | | hsusb3_tll_data2 | 5 | IO | | | | | | | | |
| | | mm3_txdat | 6 | IO | | | | | | | | |
| | | safe_mode | 7 | | | | | | | | | |
| AC1 | NA | mcbasp4_fsx | 0 | IO | L | L | 7 | vdds | Yes | 4 | PU/ PD | LVC MOS |
| | | gpio_155 | 4 | IO | | | | | | | | |
| | | hsusb3_tll_data3 | 5 | IO | | | | | | | | |
| | | mm3_txen_n | 6 | IO | | | | | | | | |
| | | safe_mode | 7 | | | | | | | | | |
| Y21 | NA | mcbasp1_clk | 0 | IO | L | L | 7 | vdds | Yes | 4 | PU/ PD | LVC MOS |
| | | mcspi4_clk | 1 | IO | | | | | | | | |
| | | gpio_156 | 4 | IO | | | | | | | | |
| | | safe_mode | 7 | | | | | | | | | |
| AA21 | NA | mcbasp1_fsr | 0 | IO | L | L | 7 | vdds | Yes | 4 | PU/ PD | LVC MOS |
| | | cam_global_reset | 2 | IO | | | | | | | | |
| | | gpio_157 | 4 | IO | | | | | | | | |
| | | safe_mode | 7 | | | | | | | | | |
| V21 | NA | mcbasp1_dx | 0 | IO | L | L | 7 | vdds | Yes | 4 | PU/ PD | LVC MOS |
| | | mcspi4_simo | 1 | IO | | | | | | | | |
| | | mcbasp3_dx | 2 | IO | | | | | | | | |
| | | gpio_158 | 4 | IO | | | | | | | | |
| | | safe_mode | 7 | | | | | | | | | |
| U21 | NA | mcbasp1_dr | 0 | I | L | L | 7 | vdds | Yes | 4 | PU/ PD | LVC MOS |
| | | mcspi4_somi | 1 | IO | | | | | | | | |
| | | mcbasp3_dr | 2 | O | | | | | | | | |
| | | gpio_159 | 4 | IO | | | | | | | | |
| | | safe_mode | 7 | | | | | | | | | |

Table 2-1. Ball Characteristics (CBB Pkg.) (continued)

| BALL BOTTOM [1] | BALL TOP [2] | PIN NAME [3] | MODE [4] | TYPE [5] | BALL RESET STATE [6] | BALL RESET REL. STATE [7] | RESET REL. MODE [8] | POWER [9] | HYS [10] | BUFFER STRENGTH (mA) [11] | PULLUP/DOWN TYPE [12] | IO CELL [13] |
|-----------------|--------------|----------------|----------|----------|----------------------|---------------------------|---------------------|-----------|----------|---------------------------|-----------------------|--------------|
| T21 | NA | mcbssp_clks | 0 | I | L | L | 7 | vdds | Yes | 4 | PU/ PD | LVCMOS |
| | | cam_shutter | 2 | O | | | | | | | | |
| | | gpio_160 | 4 | IO | | | | | | | | |
| | | uart1_cts | 5 | I | | | | | | | | |
| | | safe_mode | 7 | | | | | | | | | |
| K26 | NA | mcbssp1_fsx | 0 | IO | L | L | 7 | vdds | Yes | 4 | PU/ PD | LVCMOS |
| | | mcsmpi4_cs0 | 1 | IO | | | | | | | | |
| | | mcbssp3_fsx | 2 | IO | | | | | | | | |
| | | gpio_161 | 4 | IO | | | | | | | | |
| | | safe_mode | 7 | | | | | | | | | |
| W21 | NA | mcbssp1_clkx | 0 | IO | L | L | 7 | vdds | Yes | 4 | PU/ PD | LVCMOS |
| | | mcbssp3_clkx | 2 | IO | | | | | | | | |
| | | gpio_162 | 4 | IO | | | | | | | | |
| | | safe_mode | 7 | | | | | | | | | |
| H18 | NA | uart3_cts_rctx | 0 | IO | H | H | 7 | vdds | Yes | 4 | PU/ PD | LVCMOS |
| | | gpio_163 | 4 | IO | | | | | | | | |
| | | safe_mode | 7 | | | | | | | | | |
| H19 | NA | uart3_rts_sd | 0 | O | H | H | 7 | vdds | Yes | 4 | PU/ PD | LVCMOS |
| | | gpio_164 | 4 | IO | | | | | | | | |
| | | safe_mode | 7 | | | | | | | | | |
| H20 | NA | uart3_rx_irrx | 0 | I | H | H | 7 | vdds | Yes | 4 | PU/ PD | LVCMOS |
| | | gpio_165 | 4 | IO | | | | | | | | |
| | | safe_mode | 7 | | | | | | | | | |
| H21 | NA | uart3_tx_irtx | 0 | O | H | H | 7 | vdds | Yes | 4 | PU/ PD | LVCMOS |
| | | gpio_166 | 4 | IO | | | | | | | | |
| | | safe_mode | 7 | | | | | | | | | |
| T28 | NA | hsusb0_clk | 0 | I | L | L | 7 | vdds | Yes | 4 | PU/ PD | LVCMOS |
| | | gpio_120 | 4 | IO | | | | | | | | |
| | | safe_mode | 7 | | | | | | | | | |
| T25 | NA | hsusb0_stp | 0 | O | H | H | 7 | vdds | Yes | 4 | PU/ PD | LVCMOS |
| | | gpio_121 | 4 | IO | | | | | | | | |
| | | safe_mode | 7 | | | | | | | | | |
| R28 | NA | hsusb0_dir | 0 | I | L | L | 7 | vdds | Yes | 4 | PU/ PD | LVCMOS |
| | | gpio_122 | 4 | IO | | | | | | | | |
| | | safe_mode | 7 | | | | | | | | | |
| T26 | NA | hsusb0_nxt | 0 | I | L | L | 7 | vdds | Yes | 4 | PU/ PD | LVCMOS |
| | | gpio_124 | 4 | IO | | | | | | | | |
| | | safe_mode | 7 | | | | | | | | | |
| T27 | NA | hsusb0_data0 | 0 | IO | L | L | 7 | vdds | Yes | 4 | PU/ PD | LVCMOS |
| | | uart3_tx_irtx | 2 | O | | | | | | | | |
| | | gpio_125 | 4 | IO | | | | | | | | |
| | | safe_mode | 7 | | | | | | | | | |
| U28 | NA | hsusb0_data1 | 0 | IO | L | L | 7 | vdds | Yes | 4 | PU/ PD | LVCMOS |
| | | uart3_rx_irrx | 2 | I | | | | | | | | |
| | | gpio_130 | 4 | IO | | | | | | | | |
| | | safe_mode | 7 | | | | | | | | | |
| U27 | NA | hsusb0_data2 | 0 | IO | L | L | 7 | vdds | Yes | 4 | PU/ PD | LVCMOS |
| | | uart3_rts_sd | 2 | O | | | | | | | | |
| | | gpio_131 | 4 | IO | | | | | | | | |
| | | safe_mode | 7 | | | | | | | | | |

Table 2-1. Ball Characteristics (CBB Pkg.) (continued)

| BALL BOTTOM [1] | BALL TOP [2] | PIN NAME [3] | MODE [4] | TYPE [5] | BALL RESET STATE [6] | BALL RESET REL. STATE [7] | RESET REL. MODE [8] | POWER [9] | HYS [10] | BUFFER STRENGTH (mA) [11] | PULLUP /DOWN TYPE [12] | IO CELL [13] |
|-----------------|--------------|----------------|----------|----------|----------------------|---------------------------|---------------------|-----------|----------|---------------------------|------------------------|--------------|
| U26 | NA | hsusb0_data3 | 0 | IO | L | L | 7 | vdds | Yes | 4 | PU/ PD | LVCMOS |
| | | uart3_cts_rctx | 2 | IO | | | | | | | | |
| | | gpio_169 | 4 | IO | | | | | | | | |
| | | safe_mode | 7 | | | | | | | | | |
| U25 | NA | hsusb0_data4 | 0 | IO | L | L | 7 | vdds | Yes | 4 | PU/ PD | LVCMOS |
| | | gpio_188 | 4 | IO | | | | | | | | |
| | | safe_mode | 7 | | | | | | | | | |
| V28 | NA | hsusb0_data5 | 0 | IO | L | L | 7 | vdds | Yes | 4 | PU/ PD | LVCMOS |
| | | gpio_189 | 4 | IO | | | | | | | | |
| | | safe_mode | 7 | | | | | | | | | |
| V27 | NA | hsusb0_data6 | 0 | IO | L | L | 7 | vdds | Yes | 4 | PU/ PD | LVCMOS |
| | | gpio_190 | 4 | IO | | | | | | | | |
| | | safe_mode | 7 | | | | | | | | | |
| V26 | NA | hsusb0_data7 | 0 | IO | L | L | 7 | vdds | Yes | 4 | PU/ PD | LVCMOS |
| | | gpio_191 | 4 | IO | | | | | | | | |
| | | safe_mode | 7 | | | | | | | | | |
| K21 | NA | i2c1_scl | 0 | IOD | H | H | 0 | vdds | Yes | 4 | PU/ PD | Open Drain |
| J21 | NA | i2c1_sda | 0 | IOD | H | H | 0 | vdds | Yes | 4 | PU/ PD | Open Drain |
| AF15 | NA | i2c2_scl | 0 | IOD | H | H | 7 | vdds | Yes | 4 | PU/ PD | Open Drain |
| | | gpio_168 | 4 | IO | | | | | | | | |
| | | safe_mode | 7 | | | | | | | | | |
| AE15 | NA | i2c2_sda | 0 | IOD | H | H | 7 | vdds | Yes | 4 | PU/ PD | Open Drain |
| | | gpio_183 | 4 | IO | | | | | | | | |
| | | safe_mode | 7 | | | | | | | | | |
| AF14 | NA | i2c3_scl | 0 | IOD | H | H | 7 | vdds | Yes | 4 | PU/ PD | Open Drain |
| | | gpio_184 | 4 | IO | | | | | | | | |
| | | safe_mode | 7 | | | | | | | | | |
| AG14 | NA | i2c3_sda | 0 | IOD | H | H | 7 | vdds | Yes | 4 | PU/ PD | Open Drain |
| | | gpio_185 | 4 | IO | | | | | | | | |
| | | safe_mode | 7 | | | | | | | | | |
| AD26 | NA | i2c4_scl | 0 | IOD | H | H | 0 | vdds | Yes | 4 | PU/ PD | Open Drain |
| | | sys_nvmode1 | 1 | O | | | | | | | | |
| | | safe_mode | 7 | | | | | | | | | |
| AE26 | NA | i2c4_sda | 0 | IOD | H | H | 0 | vdds | Yes | 4 | PU/ PD | Open Drain |
| | | sys_nvmode2 | 1 | O | | | | | | | | |
| | | safe_mode | 7 | | | | | | | | | |
| J25 | NA | hdq_sio | 0 | IOD | H | H | 7 | vdds | Yes | 4 | PU/ PD | LVCMOS |
| | | sys_altclk | 1 | I | | | | | | | | |
| | | i2c2_sccbe | 2 | O | | | | | | | | |
| | | i2c3_sccbe | 3 | O | | | | | | | | |
| | | gpio_170 | 4 | IO | | | | | | | | |
| | | safe_mode | 7 | | | | | | | | | |
| AB3 | NA | mcspi1_clk | 0 | IO | L | L | 7 | vdds | Yes | 4 ⁽³⁾ | PU/ PD | LVCMOS |
| | | mmc2_dat4 | 1 | IO | | | | | | | | |
| | | gpio_171 | 4 | IO | | | | | | | | |
| | | safe_mode | 7 | | | | | | | | | |
| AB4 | NA | mcspi1_simo | 0 | IO | L | L | 7 | vdds | Yes | 4 ⁽³⁾ | PU/ PD | LVCMOS |
| | | mmc2_dat5 | 1 | IO | | | | | | | | |
| | | gpio_172 | 4 | IO | | | | | | | | |

Table 2-1. Ball Characteristics (CBB Pkg.) (continued)

| BALL BOTTOM [1] | BALL TOP [2] | PIN NAME [3] | MODE [4] | TYPE [5] | BALL RESET STATE [6] | BALL RESET REL. STATE [7] | RESET REL. MODE [8] | POWER [9] | HYS [10] | BUFFER STRENGTH (mA) [11] | PULLUP /DOWN TYPE [12] | IO CELL [13] |
|-----------------|--------------|------------------|----------|----------|----------------------|---------------------------|---------------------|-----------|----------|---------------------------|------------------------|--------------|
| | | safe_mode | 7 | | | | | | | | | |
| AA4 | NA | mcspi1_somi | 0 | IO | L | L | 7 | vdds | Yes | 4 ⁽³⁾ | PU/ PD | LVCMOS |
| | | mmc2_dat6 | 1 | IO | | | | | | | | |
| | | gpio_173 | 4 | IO | | | | | | | | |
| | | safe_mode | 7 | | | | | | | | | |
| AC2 | NA | mcspi1_cs0 | 0 | IO | H | H | 7 | vdds | Yes | 4 ⁽³⁾ | PU/ PD | LVCMOS |
| | | mmc2_dat7 | 1 | IO | | | | | | | | |
| | | gpio_174 | 4 | IO | | | | | | | | |
| | | safe_mode | 7 | | | | | | | | | |
| AC3 | NA | mcspi1_cs1 | 0 | O | L | H | 7 | vdds | Yes | 4 ⁽³⁾ | PU/ PD | LVCMOS |
| | | mmc3_cmd | 3 | IO | | | | | | | | |
| | | gpio_175 | 4 | IO | | | | | | | | |
| | | safe_mode | 7 | | | | | | | | | |
| AB1 | NA | mcspi1_cs2 | 0 | O | L | H | 7 | vdds | Yes | 4 ⁽³⁾ | PU/ PD | LVCMOS |
| | | mmc3_clk | 3 | O | | | | | | | | |
| | | gpio_176 | 4 | IO | | | | | | | | |
| | | safe_mode | 7 | | | | | | | | | |
| AB2 | NA | mcspi1_cs3 | 0 | O | H | H | 7 | vdds | Yes | 4 | PU/ PD | LVCMOS |
| | | hsusb2_tll_data2 | 2 | IO | | | | | | | | |
| | | hsusb2_data2 | 3 | IO | | | | | | | | |
| | | gpio_177 | 4 | IO | | | | | | | | |
| | | mm2_txdat | 5 | IO | | | | | | | | |
| | | safe_mode | 7 | | | | | | | | | |
| AA3 | NA | mcspi2_clk | 0 | IO | L | L | 7 | vdds | Yes | 4 | PU/ PD | LVCMOS |
| | | hsusb2_tll_data7 | 2 | IO | | | | | | | | |
| | | hsusb2_data7 | 3 | O | | | | | | | | |
| | | gpio_178 | 4 | IO | | | | | | | | |
| | | safe_mode | 7 | | | | | | | | | |
| Y2 | NA | mcspi2_simo | 0 | IO | L | L | 7 | vdds | Yes | 4 | PU/ PD | LVCMOS |
| | | gpt9_pwm_evt | 1 | IO | | | | | | | | |
| | | hsusb2_tll_data4 | 2 | IO | | | | | | | | |
| | | hsusb2_data4 | 3 | I | | | | | | | | |
| | | gpio_179 | 4 | IO | | | | | | | | |
| | | safe_mode | 7 | | | | | | | | | |
| Y3 | NA | mcspi2_somi | 0 | IO | L | L | 7 | vdds | Yes | 4 | PU/ PD | LVCMOS |
| | | gpt10_pwm_evt | 1 | IO | | | | | | | | |
| | | hsusb2_tll_data5 | 2 | IO | | | | | | | | |
| | | hsusb2_data5 | 3 | O | | | | | | | | |
| | | gpio_180 | 4 | IO | | | | | | | | |
| | | safe_mode | 7 | | | | | | | | | |
| Y4 | NA | mcspi2_cs0 | 0 | IO | H | H | 7 | vdds | Yes | 4 | PU/ PD | LVCMOS |
| | | gpt11_pwm_evt | 1 | IO | | | | | | | | |
| | | hsusb2_tll_data6 | 2 | IO | | | | | | | | |
| | | hsusb2_data6 | 3 | O | | | | | | | | |

Table 2-1. Ball Characteristics (CBB Pkg.) (continued)

| BALL BOTTOM [1] | BALL TOP [2] | PIN NAME [3] | MODE [4] | TYPE [5] | BALL RESET STATE [6] | BALL RESET REL. STATE [7] | RESET REL. MODE [8] | POWER [9] | HYS [10] | BUFFER STRENGTH (mA) [11] | PULLUP/DOWN TYPE [12] | IO CELL [13] |
|-----------------|--------------|------------------|----------|----------|----------------------|---------------------------|---------------------|-----------|----------|---------------------------|-----------------------|--------------|
| | | gpio_181 | 4 | IO | | | | | | | | |
| | | safe_mode | 7 | | | | | | | | | |
| V3 | NA | mcspi2_cs1 | 0 | O | L | L | 7 | vdds | Yes | 4 | PU/ PD | LVC MOS |
| | | gpt8_pwm_e vt | 1 | IO | | | | | | | | |
| | | hsusb2_tll_data3 | 2 | IO | | | | | | | | |
| | | hsusb2_data3 | 3 | IO | | | | | | | | |
| | | gpio_182 | 4 | IO | | | | | | | | |
| | | mm2_txen_n | 5 | IO | | | | | | | | |
| | | safe_mode | 7 | | | | | | | | | |
| AE25 | NA | sys_32k | 0 | I | Z | I | NA | vdds | Yes | NA | NA | LVC MOS |
| AE17 | NA | sys_xtalin | 0 | I | Z | I | NA | vdds | NA | NA | NA | LVC MOS |
| AF17 | NA | sys_xtalout | 0 | O | Z | O | NA | vdds | NA | NA | NA | LVC MOS |
| AF25 | NA | sys_clkreq | 0 | IO | 0 | 1 | 0 | vdds | Yes | 8 | PU/ PD | LVC MOS |
| | | gpio_1 | 4 | IO | | | | | | | | |
| | | safe_mode | 7 | | | | | | | | | |
| AF26 | NA | sys_nirq | 0 | I | H | H | 7 | vdds | Yes | 4 | PU/ PD | LVC MOS |
| | | gpio_0 | 4 | IO | | | | | | | | |
| | | safe_mode | 7 | | | | | | | | | |
| AH25 | NA | sys_nrespwron | 0 | I | Z | I | NA | vdds | Yes | NA | NA | LVC MOS |
| AF24 | NA | sys_nreswarm | 0 | I/O D | 0 | 1 (PU) | 0 | vdds | Yes | 8 | PU/ PD | LVC MOS |
| | | gpio_30 | 4 | IO | | | | | | | | Open Drain |
| | | safe_mode | 7 | | | | | | | | | |
| AH26 | NA | sys_boot0 | 0 | I | Z | Z | 0 | vdds | Yes | 4 | PU/ PD | LVC MOS |
| | | gpio_2 | 4 | IO | | | | | | | | |
| | | safe_mode | 7 | | | | | | | | | |
| AG26 | NA | sys_boot1 | 0 | I | Z | Z | 0 | vdds | Yes | 4 | PU/ PD | LVC MOS |
| | | gpio_3 | 4 | IO | | | | | | | | |
| | | safe_mode | 7 | | | | | | | | | |
| AE14 | NA | sys_boot2 | 0 | I | Z | Z | 0 | vdds | Yes | 4 | PU/ PD | LVC MOS |
| | | gpio_4 | 4 | IO | | | | | | | | |
| | | safe_mode | 7 | | | | | | | | | |
| AF18 | NA | sys_boot3 | 0 | I | Z | Z | 0 | vdds | Yes | 4 | PU/ PD | LVC MOS |
| | | gpio_5 | 4 | IO | | | | | | | | |
| | | safe_mode | 7 | | | | | | | | | |
| AF19 | NA | sys_boot4 | 0 | I | Z | Z | 0 | vdds | Yes | 4 | PU/ PD | LVC MOS |
| | | mmc2_dir_data2 | 1 | O | | | | | | | | |
| | | gpio_6 | 4 | IO | | | | | | | | |
| | | safe_mode | 7 | | | | | | | | | |
| AE21 | NA | sys_boot5 | 0 | I | Z | Z | 0 | vdds | Yes | 4 | PU/ PD | LVC MOS |
| | | mmc2_dir_data3 | 1 | O | | | | | | | | |
| | | gpio_7 | 4 | IO | | | | | | | | |
| | | safe_mode | 7 | | | | | | | | | |
| AF21 | NA | sys_boot6 | 0 | I | Z | Z | 0 | vdds | Yes | 4 | PU/ PD | LVC MOS |
| | | gpio_8 | 4 | IO | | | | | | | | |
| | | safe_mode | 7 | | | | | | | | | |
| AF22 | NA | sys_off_mode | 0 | O | 0 | L | 7 | vdds | Yes | 8 | PU/ PD | LVC MOS |
| | | gpio_9 | 4 | IO | | | | | | | | |
| | | safe_mode | 7 | | | | | | | | | |
| AG25 | NA | sys_clkout1 | 0 | O | L | L | 7 | vdds | Yes | 8 | PU/ PD | LVC MOS |

Table 2-1. Ball Characteristics (CBB Pkg.) (continued)

| BALL BOTTOM [1] | BALL TOP [2] | PIN NAME [3] | MODE [4] | TYPE [5] | BALL RESET STATE [6] | BALL RESET REL. STATE [7] | RESET REL. MODE [8] | POWER [9] | HYS [10] | BUFFER STRENGTH (mA) [11] | PULLUP /DOWN TYPE [12] | IO CELL [13] |
|-----------------|--------------|------------------|----------|----------|----------------------|---------------------------|---------------------|-----------|----------|---------------------------|------------------------|--------------|
| | | gpio_10 | 4 | IO | | | | | | | | |
| | | safe_mode | 7 | | | | | | | | | |
| AE22 | NA | sys_clkout2 | 0 | O | L | L | 7 | vdds | Yes | 4 | PU/ PD | LVC MOS |
| | | gpio_186 | 4 | IO | | | | | | | | |
| | | safe_mode | 7 | | | | | | | | | |
| AA17 | NA | jtag_nrst | 0 | I | L | L | 0 | vdds | Yes | NA | PU/ PD | LVC MOS |
| AA13 | NA | jtag_tck | 0 | I | L | L | 0 | vdds | Yes | NA | PU/ PD | LVC MOS |
| AA12 | NA | jtag_rtk | 0 | O | L | 0 | 0 | vdds | Yes | 8 | PU/ PD | LVC MOS |
| AA18 | NA | jtag_tms_tmsc | 0 | IO | H | H | 0 | vdds | Yes | 8 | PU/ PD | LVC MOS |
| AA20 | NA | jtag_tdi | 0 | I | H | H | 0 | vdds | Yes | NA | PU/ PD | LVC MOS |
| AA19 | NA | jtag_tdo | 0 | O | L | Z | 0 | vdds | Yes | 8 | PU/ PD | LVC MOS |
| AA11 | NA | jtag_emu0 | 0 | IO | H | H | 0 | vdds | Yes | 8 | PU/ PD | LVC MOS |
| | | gpio_11 | 4 | IO | | | | | | | | |
| | | safe_mode | 7 | | | | | | | | | |
| AA10 | NA | jtag_emu1 | 0 | IO | H | H | 0 | vdds | Yes | 8 | PU/ PD | LVC MOS |
| | | gpio_31 | 4 | IO | | | | | | | | |
| | | safe_mode | 7 | | | | | | | | | |
| AF10 | NA | etk_clk | 0 | O | H | H | 4 | vdds | Yes | 4 | PU/ PD | LVC MOS |
| | | mcbasp5_clkx | 1 | IO | | | | | | | | |
| | | mmc3_clk | 2 | O | | | | | | | | |
| | | hsusb1_stp | 3 | O | | | | | | | | |
| | | gpio_12 | 4 | IO | | | | | | | | |
| | | mm1_rxdp | 5 | IO | | | | | | | | |
| | | hsusb1_tll_stp | 6 | I | | | | | | | | |
| AE10 | NA | etk_ctl | 0 | O | H | H | 4 | vdds | Yes | 4 | PU/ PD | LVC MOS |
| | | mmc3_cmd | 2 | IO | | | | | | | | |
| | | hsusb1_clk | 3 | O | | | | | | | | |
| | | gpio_13 | 4 | IO | | | | | | | | |
| | | hsusb1_tll_clk | 6 | O | | | | | | | | |
| AF11 | NA | etk_d0 | 0 | O | H | H | 4 | vdds | Yes | 4 | PU/ PD | LVC MOS |
| | | mcspi3_simo | 1 | IO | | | | | | | | |
| | | mmc3_dat4 | 2 | IO | | | | | | | | |
| | | hsusb1_data0 | 3 | IO | | | | | | | | |
| | | gpio_14 | 4 | IO | | | | | | | | |
| | | mm1_rxcv | 5 | IO | | | | | | | | |
| | | hsusb1_tll_data0 | 6 | IO | | | | | | | | |
| AG12 | NA | etk_d1 | 0 | O | H | H | 4 | vdds | Yes | 4 | PU/ PD | LVC MOS |
| | | mcspi3_somi | 1 | IO | | | | | | | | |
| | | hsusb1_data1 | 3 | IO | | | | | | | | |
| | | gpio_15 | 4 | IO | | | | | | | | |
| | | mm1_txse0 | 5 | IO | | | | | | | | |
| | | hsusb1_tll_data1 | 6 | IO | | | | | | | | |
| AH12 | NA | etk_d2 | 0 | O | H | H | 4 | vdds | Yes | 4 | PU/ PD | LVC MOS |
| | | mcspi3_cs0 | 1 | IO | | | | | | | | |
| | | hsusb1_data2 | 3 | IO | | | | | | | | |
| | | gpio_16 | 4 | IO | | | | | | | | |
| | | mm1_txdat | 5 | IO | | | | | | | | |

Table 2-1. Ball Characteristics (CBB Pkg.) (continued)

| BALL BOTTOM [1] | BALL TOP [2] | PIN NAME [3] | MODE [4] | TYPE [5] | BALL RESET STATE [6] | BALL RESET REL. STATE [7] | RESET REL. MODE [8] | POWER [9] | HYS [10] | BUFFER STRENGTH (mA) [11] | PULLUP /DOWN TYPE [12] | IO CELL [13] |
|------------------|--------------|----------------------|----------|----------|----------------------|---------------------------|---------------------|-----------|----------|---------------------------|------------------------|--------------|
| | | hsusb1_tll_data2 | 6 | IO | | | | | | | | |
| AE13 | NA | etk_d3 | 0 | O | H | H | 4 | vdds | Yes | 4 | PU/ PD | LVCMOS |
| | | mcspi3_clk | 1 | IO | | | | | | | | |
| | | mmc3_dat3 | 2 | IO | | | | | | | | |
| | | hsusb1_data7 | 3 | IO | | | | | | | | |
| | | gpio_17 | 4 | IO | | | | | | | | |
| | | hsusb1_tll_data7 | 6 | IO | | | | | | | | |
| AE11 | NA | etk_d4 | 0 | O | L | L | 4 | vdds | Yes | 4 | PU/ PD | LVCMOS |
| | | mcbsp5_dr | 1 | I | | | | | | | | |
| | | mmc3_dat0 | 2 | IO | | | | | | | | |
| | | hsusb1_data4 | 3 | IO | | | | | | | | |
| | | gpio_18 | 4 | IO | | | | | | | | |
| | | hsusb1_tll_data4 | 6 | IO | | | | | | | | |
| AH9 | NA | etk_d5 | 0 | O | L | L | 4 | vdds | Yes | 4 | PU/ PD | LVCMOS |
| | | mcbsp5_fsx | 1 | IO | | | | | | | | |
| | | mmc3_dat1 | 2 | IO | | | | | | | | |
| | | hsusb1_data5 | 3 | IO | | | | | | | | |
| | | gpio_19 | 4 | IO | | | | | | | | |
| | | hsusb1_tll_data5 | 6 | IO | | | | | | | | |
| AF13 | NA | etk_d6 | 0 | O | L | L | 4 | vdds | Yes | 4 | PU/ PD | LVCMOS |
| | | mcbsp5_dx | 1 | IO | | | | | | | | |
| | | mmc3_dat2 | 2 | IO | | | | | | | | |
| | | hsusb1_data6 | 3 | IO | | | | | | | | |
| | | gpio_20 | 4 | IO | | | | | | | | |
| | | hsusb1_tll_data6 | 6 | IO | | | | | | | | |
| AH14 | NA | etk_d7 | 0 | O | L | L | 4 | vdds | Yes | 4 | PU/ PD | LVCMOS |
| | | mcspi3_cs1 | 1 | O | | | | | | | | |
| | | mmc3_dat7 | 2 | IO | | | | | | | | |
| | | hsusb1_data3 | 3 | IO | | | | | | | | |
| | | gpio_21 | 4 | IO | | | | | | | | |
| | | mm1_txen_n | 5 | IO | | | | | | | | |
| hsusb1_tll_data3 | 6 | IO | | | | | | | | | | |
| AF9 | NA | etk_d8 | 0 | O | L | L | 4 | vdds | Yes | 4 | PU/ PD | LVCMOS |
| | | sys_drm_msecure | 1 | I | | | | | | | | |
| | | mmc3_dat6 | 2 | IO | | | | | | | | |
| | | hsusb1_dir | 3 | I | | | | | | | | |
| | | gpio_22 | 4 | IO | | | | | | | | |
| | | hsusb1_tll_dir | 6 | O | | | | | | | | |
| AG9 | NA | etk_d9 | 0 | O | L | L | 4 | vdds | Yes | 4 | PU/ PD | LVCMOS |
| | | sys_secure_indicator | 1 | O | | | | | | | | |
| | | mmc3_dat5 | 2 | IO | | | | | | | | |
| | | hsusb1_nxt | 3 | I | | | | | | | | |
| | | gpio_23 | 4 | IO | | | | | | | | |
| | | mm1_rxdm | 5 | IO | | | | | | | | |
| hsusb1_tll_nxt | 6 | O | | | | | | | | | | |

Table 2-1. Ball Characteristics (CBB Pkg.) (continued)

| BALL BOTTOM [1] | BALL TOP [2] | PIN NAME [3] | MODE [4] | TYPE [5] | BALL RESET STATE [6] | BALL RESET REL. STATE [7] | RESET REL. MODE [8] | POWER [9] | HYS [10] | BUFFER STRENGTH (mA) [11] | PULLUP/DOWN TYPE [12] | IO CELL [13] |
|---|--------------|------------------|----------|----------|----------------------|---------------------------|---------------------|-----------|----------|---------------------------|-----------------------|--------------|
| AE7 | NA | etk_d10 | 0 | O | L | L | 4 | vdds | Yes | 4 | PU/ PD | LVCMOS |
| | | uart1_rx | 2 | I | | | | | | | | |
| | | hsusb2_clk | 3 | O | | | | | | | | |
| | | gpio_24 | 4 | IO | | | | | | | | |
| | | hsusb2_tll_clk | 6 | O | | | | | | | | |
| AF7 | NA | etk_d11 | 0 | O | L | L | 4 | vdds | Yes | 4 | PU/ PD | LVCMOS |
| | | hsusb2_stp | 3 | O | | | | | | | | |
| | | gpio_25 | 4 | IO | | | | | | | | |
| | | mm2_rxdp | 5 | IO | | | | | | | | |
| | | hsusb2_tll_stp | 6 | I | | | | | | | | |
| AG7 | NA | etk_d12 | 0 | O | L | L | 4 | vdds | Yes | 4 | PU/ PD | LVCMOS |
| | | hsusb2_dir | 3 | I | | | | | | | | |
| | | gpio_26 | 4 | IO | | | | | | | | |
| | | hsusb2_tll_dir | 6 | O | | | | | | | | |
| AH7 | NA | etk_d13 | 0 | O | L | L | 4 | vdds | Yes | 4 | PU/ PD | LVCMOS |
| | | hsusb2_nxt | 3 | I | | | | | | | | |
| | | gpio_27 | 4 | IO | | | | | | | | |
| | | mm2_rxdm | 5 | IO | | | | | | | | |
| | | hsusb2_tll_nxt | 6 | O | | | | | | | | |
| AG8 | NA | etk_d14 | 0 | O | L | L | 4 | vdds | Yes | 4 | PU/ PD | LVCMOS |
| | | hsusb2_data0 | 3 | IO | | | | | | | | |
| | | gpio_28 | 4 | IO | | | | | | | | |
| | | mm2_rxcv | 5 | IO | | | | | | | | |
| | | hsusb2_tll_data0 | 6 | IO | | | | | | | | |
| AH8 | NA | etk_d15 | 0 | O | L | L | 4 | vdds | Yes | 4 | PU/ PD | LVCMOS |
| | | hsusb2_data1 | 3 | IO | | | | | | | | |
| | | gpio_29 | 4 | IO | | | | | | | | |
| | | mm2_txse0 | 5 | IO | | | | | | | | |
| | | hsusb2_tll_data1 | 6 | IO | | | | | | | | |
| AE9, AE18, AE19, AE24, AC4, Y16, Y18, Y19, Y20, W18, W20, V20, U19, U20, T19, P20, N19, N20, M19, M25, L25, K18, K20, J4, J18, J19, J20, H4, E25, D8, D9, D15, D22, D23 | NA | vdd_core | 0 | PWR | - | - | - | - | - | - | - | - |
| Y9, Y10, Y11, Y14, Y15, W9, W11, W12, W15, U10, T9, T10, R9, R10, N10, M9, M10, L9, L10, K11, K14, K13, J9, J10, J11, J14, J15 | NA | vdd_mpu_iva | 0 | PWR | - | - | - | - | - | - | - | - |

Table 2-1. Ball Characteristics (CBB Pkg.) (continued)

| BALL BOTTOM [1] | BALL TOP [2] | PIN NAME [3] | MODE [4] | TYPE [5] | BALL RESET STATE [6] | BALL RESET REL. STATE [7] | RESET REL. MODE [8] | POWER [9] | HYS [10] | BUFFER STRENGTH (mA) [11] | PULLUP /DOWN TYPE [12] | IO CELL [13] |
|--|--------------|--|----------|----------|----------------------|---------------------------|---------------------|-----------|----------|---------------------------|------------------------|--------------|
| AH6, U1, R4, J1, J2, G28, F1, F2, D16, C16, C28, B5, B8, B12, B18, B22, A5, A8, A12, A18, A22 | NA | vdds_mem | 0 | PWR | - | - | - | - | - | - | - | - |
| AG20, AG21, AG27, AF8, AF16, AF23, AE8, AE16, AE23, AE27, AD3, AD4, W4, H28, F25, F26 | NA | vdds | 0 | PWR | - | - | - | - | - | - | - | - |
| W16 | NA | vdds_sram | 0 | | | | | | | | | |
| K15 | NA | vdds_dpll_dll | 0 | PWR | - | - | - | - | - | - | - | - |
| AA16 | NA | vdds_dpll_per | 0 | PWR | - | - | - | - | - | - | - | - |
| AA14 | NA | vdds_wkup_bg | 0 | PWR | - | - | - | - | - | - | - | - |
| K25, P25 | NA | vdds_mmc1, vdds_mmc1a | 0 | PWR | - | - | - | - | - | - | - | - |
| V25 | NA | vdda_dac | 0 | PWR | - | - | - | - | - | - | - | - |
| Y26 | NA | vssa_dac | 0 | GND | - | - | - | - | - | - | - | - |
| AA26, AG2, AG3, AG6, AF12, AF20, AE12, AE20, AC25, AC26, AG16, AH21, Y12, Y13, Y17, Y25, W3, W10, W13, W14, W17, W19, W25, V9, V10, V19, U2, U9, T20, R19, R20, R26, P3, P4, P9, P10, P19, N9, M20, M28, L19, L20, L26, K9, K10, K12, K16, K17, K19, J3, J12, J13, J16, J17, G27, E3, E4, D7, D10, D13, D19, D21, C7, C10, C13, C19, C22, B2, B27, A3, A26 | NA | vss | 0 | GND | - | - | - | - | - | - | - | - |
| AH20, AA15, V4, L21 | NA | cap_vdd_d, cap_vdd_wkup, cap_vdd_sram_mpu_iva, cap_vdd_sram_core | 0 | PWR | - | - | - | - | - | - | - | - |

Table 2-1. Ball Characteristics (CBB Pkg.) (continued)

| BALL BOTTOM [1] | BALL TOP [2] | PIN NAME [3] | MODE [4] | TYPE [5] | BALL RESET STATE [6] | BALL RESET REL. STATE [7] | RESET REL. MODE [8] | POWER [9] | HYS [10] | BUFFER STRENGTH (mA) [11] | PULLUP /DOWN TYPE [12] | IO CELL [13] |
|---|--|---------------------------------|----------|----------|----------------------|---------------------------|---------------------|-----------|----------|---------------------------|------------------------|--------------|
| AH1, AH2, AH10, AH11, AH13, AH15, AH16, AH27, AH28, AG1, AG10, AG11, AG13, AG15, AG28, AF1, AF2, AF27, AF28, AE28, AA1, AA2, N1, N2, M1, M2, M26, J27, J28, B15, B28, A2, A15, A27, A28 | A2, A12, A22, A23, AA1, AA2, AA22, AA23, AB1, AB11, AB13, AB23, AB8, AB9, AC1, AC11, AC13, AC14, AC2, AC22, AC23, AC8, AC9, B12, B23, H22, H23, K1, K2, K22, L1, L2, U1, U2, Y23 | FeedThrough Pins ⁽⁵⁾ | - | - | - | - | - | - | - | - | - | - |
| A1, B1, G1, U4 | A1, AB2, AB22, B1, B2, B22 | No Connect | - | - | - | - | - | - | - | - | - | - |

(5) These signals are feed-through balls. For more information, see [Section 2.5.10](#).

Table 2-2. Ball Characteristics (CBC Pkg.)⁽¹⁾

| BALL BOTTOM [1] | BALL TOP [2] | PIN NAME [3] | MODE [4] | TYPE [5] | BALL RESET STATE [6] | BALL RESET REL. STATE [7] | RESET REL. MODE [8] | POWER [9] | HYS [10] | BUFFER STRENGTH (mA) [11] | PULLUP /DOWN TYPE [12] | IO CELL [13] |
|-----------------|--------------|--------------|----------|----------|----------------------|---------------------------|---------------------|-----------|----------|---------------------------|------------------------|--------------|
| AE16 | NA | cam_d0 | 0 | I | L | L | 7 | vdds | Yes | 4 | PU100/ PD100 | LVC MOS |
| | | gpio_99 | 4 | I | | | | | | | | |
| | | safe_mode | 7 | - | | | | | | | | |
| AE15 | NA | cam_d1 | 0 | I | L | L | 7 | vdds | Yes | 4 | PU100/ PD100 | LVC MOS |
| | | gpio_100 | 4 | I | | | | | | | | |
| | | safe_mode | 7 | - | | | | | | | | |
| AD17 | NA | gpio_112 | 4 | I | L | L | 7 | vdds | Yes | 4 | PU100/ PD100 | LVC MOS |
| | | safe_mode | 7 | - | | | | | | | | |
| AE18 | NA | gpio_114 | 4 | I | L | L | 7 | vdds | Yes | 4 | PU100/ PD100 | LVC MOS |
| | | safe_mode | 7 | - | | | | | | | | |
| AD16 | NA | gpio_113 | 4 | I | L | L | 7 | vdds | Yes | 4 | PU100/ PD100 | LVC MOS |
| | | safe_mode | 7 | - | | | | | | | | |
| AE17 | NA | gpio_115 | 4 | I | L | L | 7 | vdds | Yes | 4 | PU100/ PD100 | LVC MOS |
| | | safe_mode | 7 | - | | | | | | | | |
| NA | G20 | sdr_c_a0 | 0 | O | 0 | 0 | 0 | vdds | No | 4 ⁽²⁾ | NA | LVC MOS |
| NA | K20 | sdr_c_a1 | 0 | O | 0 | 0 | 0 | vdds | No | 4 ⁽²⁾ | NA | LVC MOS |
| NA | J20 | sdr_c_a2 | 0 | O | 0 | 0 | 0 | vdds | No | 4 ⁽²⁾ | NA | LVC MOS |
| NA | J21 | sdr_c_a3 | 0 | O | 0 | 0 | 0 | vdds | No | 4 ⁽²⁾ | NA | LVC MOS |
| NA | U21 | sdr_c_a4 | 0 | O | 0 | 0 | 0 | vdds | No | 4 ⁽²⁾ | NA | LVC MOS |
| NA | R20 | sdr_c_a5 | 0 | O | 0 | 0 | 0 | vdds | No | 4 ⁽²⁾ | NA | LVC MOS |
| NA | M21 | sdr_c_a6 | 0 | O | 0 | 0 | 0 | vdds | No | 4 ⁽²⁾ | NA | LVC MOS |
| NA | M20 | sdr_c_a7 | 0 | O | 0 | 0 | 0 | vdds | No | 4 ⁽²⁾ | NA | LVC MOS |
| NA | N20 | sdr_c_a8 | 0 | O | 0 | 0 | 0 | vdds | No | 4 ⁽²⁾ | NA | LVC MOS |
| NA | K21 | sdr_c_a9 | 0 | O | 0 | 0 | 0 | vdds | No | 4 ⁽²⁾ | NA | LVC MOS |
| NA | Y16 | sdr_c_a10 | 0 | O | 0 | 0 | 0 | vdds | No | 4 ⁽²⁾ | NA | LVC MOS |
| NA | N21 | sdr_c_a11 | 0 | O | 0 | 0 | 0 | vdds | No | 4 ⁽²⁾ | NA | LVC MOS |
| NA | R21 | sdr_c_a12 | 0 | O | 0 | 0 | 0 | vdds | No | 4 ⁽²⁾ | NA | LVC MOS |
| NA | AA15 | sdr_c_a13 | 0 | O | 0 | 0 | 0 | vdds | No | 4 ⁽²⁾ | NA | LVC MOS |
| NA | Y12 | sdr_c_a14 | 0 | O | 0 | 0 | 0 | vdds | No | 4 ⁽²⁾ | NA | LVC MOS |

(1) NA in this table stands for Not Applicable.

(2) The drive strength is programmable vs the capacity load: load range = [2 pF to 6 pF] per default or [6 pF to 12 pF] according to the selected mode.

Table 2-2. Ball Characteristics (CBC Pkg.) (continued)

| BALL BOTTOM [1] | BALL TOP [2] | PIN NAME [3] | MODE [4] | TYPE [5] | BALL RESET STATE [6] | BALL RESET REL. STATE [7] | RESET REL. MODE [8] | POWER [9] | HYS [10] | BUFFER STRENGTH (mA) [11] | PULLUP /DOWN TYPE [12] | IO CELL [13] |
|-----------------|--------------|--------------|----------|----------|----------------------|---------------------------|---------------------|-----------|----------|---------------------------|------------------------|--------------|
| NA | AA18 | sdr_c_ba0 | 0 | O | 0 | 0 | 0 | vdds | No | 4 ⁽²⁾ | NA | LVC MOS |
| NA | V20 | sdr_c_ba1 | 0 | O | 0 | 0 | 0 | vdds | No | 4 ⁽²⁾ | NA | LVC MOS |
| NA | Y15 | sdr_c_cke0 | 0 | O | H | 1 | 7 | vdds | Yes | 4 ⁽²⁾ | PU100/ PD100 | LVC MOS |
| | | safe_mode | 7 | | | | | | | | | |
| NA | Y13 | sdr_c_cke1 | 0 | O | H | 1 | 7 | vdds | Yes | 4 ⁽²⁾ | PU100/ PD100 | LVC MOS |
| | | safe_mode | 7 | | | | | | | | | |
| NA | A12 | sdr_c_clk | 0 | IO | L | 0 | 0 | vdds | Yes | 4 ⁽²⁾ | PU100/ PD100 | LVC MOS |
| NA | D1 | sdr_c_d0 | 0 | IO | L | Z | 0 | vdds | Yes | 4 ⁽²⁾ | PU100/ PD100 | LVC MOS |
| NA | G1 | sdr_c_d1 | 0 | IO | L | Z | 0 | vdds | Yes | 4 ⁽²⁾ | PU100/ PD100 | LVC MOS |
| NA | G2 | sdr_c_d2 | 0 | IO | L | Z | 0 | vdds | Yes | 4 ⁽²⁾ | PU100/ PD100 | LVC MOS |
| NA | E1 | sdr_c_d3 | 0 | IO | L | Z | 0 | vdds | Yes | 4 ⁽²⁾ | PU100/ PD100 | LVC MOS |
| NA | D2 | sdr_c_d4 | 0 | IO | L | Z | 0 | vdds | Yes | 4 ⁽²⁾ | PU100/ PD100 | LVC MOS |
| NA | E2 | sdr_c_d5 | 0 | IO | L | Z | 0 | vdds | Yes | 4 ⁽²⁾ | PU100/ PD100 | LVC MOS |
| NA | B3 | sdr_c_d6 | 0 | IO | L | Z | 0 | vdds | Yes | 4 ⁽²⁾ | PU100/ PD100 | LVC MOS |
| NA | B4 | sdr_c_d7 | 0 | IO | L | Z | 0 | vdds | Yes | 4 ⁽²⁾ | PU100/ PD100 | LVC MOS |
| NA | A10 | sdr_c_d8 | 0 | IO | L | Z | 0 | vdds | Yes | 4 ⁽²⁾ | PU100/ PD100 | LVC MOS |
| NA | B11 | sdr_c_d9 | 0 | IO | L | Z | 0 | vdds | Yes | 4 ⁽²⁾ | PU100/ PD100 | LVC MOS |
| NA | A11 | sdr_c_d10 | 0 | IO | L | Z | 0 | vdds | Yes | 4 ⁽²⁾ | PU100/ PD100 | LVC MOS |
| NA | B12 | sdr_c_d11 | 0 | IO | L | Z | 0 | vdds | Yes | 4 ⁽²⁾ | PU100/ PD100 | LVC MOS |
| NA | A16 | sdr_c_d12 | 0 | IO | L | Z | 0 | vdds | Yes | 4 ⁽²⁾ | PU100/ PD100 | LVC MOS |
| NA | A17 | sdr_c_d13 | 0 | IO | L | Z | 0 | vdds | Yes | 4 ⁽²⁾ | PU100/ PD100 | LVC MOS |
| NA | B17 | sdr_c_d14 | 0 | IO | L | Z | 0 | vdds | Yes | 4 ⁽²⁾ | PU100/ PD100 | LVC MOS |
| NA | B18 | sdr_c_d15 | 0 | IO | L | Z | 0 | vdds | Yes | 4 ⁽²⁾ | PU100/ PD100 | LVC MOS |
| NA | B7 | sdr_c_d16 | 0 | IO | L | Z | 0 | vdds | Yes | 4 ⁽²⁾ | PU100/ PD100 | LVC MOS |
| NA | A5 | sdr_c_d17 | 0 | IO | L | Z | 0 | vdds | Yes | 4 ⁽²⁾ | PU100/ PD100 | LVC MOS |
| NA | B6 | sdr_c_d18 | 0 | IO | L | Z | 0 | vdds | Yes | 4 ⁽²⁾ | PU100/ PD100 | LVC MOS |
| NA | A6 | sdr_c_d19 | 0 | IO | L | Z | 0 | vdds | Yes | 4 ⁽²⁾ | PU100/ PD100 | LVC MOS |
| NA | A8 | sdr_c_d20 | 0 | IO | L | Z | 0 | vdds | Yes | 4 ⁽²⁾ | PU100/ PD100 | LVC MOS |
| NA | B9 | sdr_c_d21 | 0 | IO | L | Z | 0 | vdds | Yes | 4 ⁽²⁾ | PU100/ PD100 | LVC MOS |
| NA | A9 | sdr_c_d22 | 0 | IO | L | Z | 0 | vdds | Yes | 4 ⁽²⁾ | PU100/ PD100 | LVC MOS |
| NA | B10 | sdr_c_d23 | 0 | IO | L | Z | 0 | vdds | Yes | 4 ⁽²⁾ | PU100/ PD100 | LVC MOS |
| NA | C21 | sdr_c_d24 | 0 | IO | L | Z | 0 | vdds | Yes | 4 ⁽²⁾ | PU100/ PD100 | LVC MOS |
| NA | D20 | sdr_c_d25 | 0 | IO | L | Z | 0 | vdds | Yes | 4 ⁽²⁾ | PU100/ PD100 | LVC MOS |
| NA | B19 | sdr_c_d26 | 0 | IO | L | Z | 0 | vdds | Yes | 4 ⁽²⁾ | PU100/ PD100 | LVC MOS |
| NA | C20 | sdr_c_d27 | 0 | IO | L | Z | 0 | vdds | Yes | 4 ⁽²⁾ | PU100/ PD100 | LVC MOS |

Table 2-2. Ball Characteristics (CBC Pkg.) (continued)

| BALL BOTTOM [1] | BALL TOP [2] | PIN NAME [3] | MODE [4] | TYPE [5] | BALL RESET STATE [6] | BALL RESET REL. STATE [7] | RESET REL. MODE [8] | POWER [9] | HYS [10] | BUFFER STRENGTH (mA) [11] | PULLUP /DOWN TYPE [12] | IO CELL [13] |
|-----------------|--------------|---------------|----------|----------|----------------------|---------------------------|---------------------|-----------|----------|---------------------------|------------------------|--------------|
| NA | D21 | sdrc_d28 | 0 | IO | L | Z | 0 | vdds | Yes | 4 ⁽²⁾ | PU100/ PD100 | LVC MOS |
| NA | E20 | sdrc_d29 | 0 | IO | L | Z | 0 | vdds | Yes | 4 ⁽²⁾ | PU100/ PD100 | LVC MOS |
| NA | E21 | sdrc_d30 | 0 | IO | L | Z | 0 | vdds | Yes | 4 ⁽²⁾ | PU100/ PD100 | LVC MOS |
| NA | G21 | sdrc_d31 | 0 | IO | L | Z | 0 | vdds | Yes | 4 ⁽²⁾ | PU100/ PD100 | LVC MOS |
| NA | H1 | sdrc_dm0 | 0 | O | 0 | 0 | 0 | vdds | No | 4 ⁽²⁾ | NA | LVC MOS |
| NA | A14 | sdrc_dm1 | 0 | O | 0 | 0 | 0 | vdds | No | 4 ⁽²⁾ | NA | LVC MOS |
| NA | A4 | sdrc_dm2 | 0 | O | 0 | 0 | 0 | vdds | No | 4 ⁽²⁾ | NA | LVC MOS |
| NA | A18 | sdrc_dm3 | 0 | O | 0 | 0 | 0 | vdds | No | 4 ⁽²⁾ | NA | LVC MOS |
| NA | C2 | sdrc_dqs0 | 0 | IO | L | Z | 0 | vdds | Yes | 4 ⁽²⁾ | PU100/ PD100 | LVC MOS |
| NA | B15 | sdrc_dqs1 | 0 | IO | L | Z | 0 | vdds | Yes | 4 ⁽²⁾ | PU100/ PD100 | LVC MOS |
| NA | B8 | sdrc_dqs2 | 0 | IO | L | Z | 0 | vdds | Yes | 4 ⁽²⁾ | PU100/ PD100 | LVC MOS |
| NA | A19 | sdrc_dqs3 | 0 | IO | L | Z | 0 | vdds | Yes | 4 ⁽²⁾ | PU100/ PD100 | LVC MOS |
| NA | U20 | sdrc_ncas | 0 | O | 1 | 1 | 0 | vdds | No | 4 ⁽²⁾ | NA | LVC MOS |
| NA | B13 | sdrc_nclk | 0 | O | 1 | 1 | 0 | vdds | No | 4 ⁽²⁾ | NA | LVC MOS |
| NA | T21 | sdrc_ncs0 | 0 | O | 1 | 1 | 0 | vdds | No | 4 ⁽²⁾ | NA | LVC MOS |
| NA | T20 | sdrc_ncs1 | 0 | O | 1 | 1 | 0 | vdds | No | 4 ⁽²⁾ | NA | LVC MOS |
| NA | V21 | sdrc_nras | 0 | O | 1 | 1 | 0 | vdds | No | 4 ⁽²⁾ | NA | LVC MOS |
| NA | Y18 | sdrc_nwe | 0 | O | 1 | 1 | 0 | vdds | No | 4 ⁽²⁾ | NA | LVC MOS |
| AE21 | NA | dss_data0 | 0 | IO | L | L | 7 | vdds | No | 4 | PU100/ PD100 | LVC MOS |
| | | uart1_cts | 2 | I | | | | | | | | |
| | | gpio_70 | 4 | IO | | | | | | | | |
| | | safe_mode | 7 | - | | | | | | | | |
| AE22 | NA | dss_data1 | 0 | IO | L | L | 7 | vdds | No | 4 | PU100/ PD100 | LVC MOS |
| | | uart1_rts | 2 | O | | | | | | | | |
| | | gpio_71 | 4 | IO | | | | | | | | |
| | | safe_mode | 7 | - | | | | | | | | |
| AE23 | NA | dss_data2 | 0 | IO | L | L | 7 | vdds | No | 4 | PU100/ PD100 | LVC MOS |
| | | gpio_72 | 4 | IO | | | | | | | | |
| | | safe_mode | 7 | - | | | | | | | | |
| AE24 | NA | dss_data3 | 0 | IO | L | L | 7 | vdds | No | 4 | PU100/ PD100 | LVC MOS |
| | | gpio_73 | 4 | IO | | | | | | | | |
| | | safe_mode | 7 | - | | | | | | | | |
| AD23 | NA | dss_data4 | 0 | IO | L | L | 7 | vdds | No | 4 | PU100/ PD100 | LVC MOS |
| | | uart3_rx_irrx | 2 | I | | | | | | | | |
| | | gpio_74 | 4 | IO | | | | | | | | |
| | | safe_mode | 7 | - | | | | | | | | |
| AD24 | NA | dss_data5 | 0 | IO | L | L | 7 | vdds | No | 4 | PU100/ PD100 | LVC MOS |
| | | uart3_tx_irtx | 2 | O | | | | | | | | |
| | | gpio_75 | 4 | IO | | | | | | | | |
| | | safe_mode | 7 | - | | | | | | | | |
| AC26 | NA | dss_data10 | 0 | IO | L | L | 7 | vdds | NA | 4 | PU100/ PD100 | LVC MOS |
| | | gpio_80 | 4 | IO | | | | | | | | |
| | | safe_mode | 7 | - | | | | | | | | |
| AD26 | NA | dss_data11 | 0 | IO | L | L | 7 | vdds | NA | 4 | PU100/ PD100 | LVC MOS |

Table 2-2. Ball Characteristics (CBC Pkg.) (continued)

| BALL BOTTOM [1] | BALL TOP [2] | PIN NAME [3] | MODE [4] | TYPE [5] | BALL RESET STATE [6] | BALL RESET REL. STATE [7] | RESET REL. MODE [8] | POWER [9] | HYS [10] | BUFFER STRENGTH (mA) [11] | PULLUP /DOWN TYPE [12] | IO CELL [13] |
|-----------------|--------------|---------------|----------|----------|----------------------|---------------------------|---------------------|-----------|----------|---------------------------|------------------------|--------------|
| | | gpio_81 | 4 | IO | | | | | | | | |
| | | safe_mode | 7 | - | | | | | | | | |
| AA25 | NA | dss_data12 | 0 | IO | L | L | 7 | vdds | NA | 4 | PU100/ PD100 | LVC MOS |
| | | gpio_82 | 4 | IO | | | | | | | | |
| | | safe_mode | 7 | - | | | | | | | | |
| Y25 | NA | dss_data13 | 0 | IO | L | L | 7 | vdds | NA | 4 | PU100/ PD100 | LVC MOS |
| | | gpio_83 | 4 | IO | | | | | | | | |
| | | safe_mode | 7 | - | | | | | | | | |
| AA26 | NA | dss_data14 | 0 | IO | L | L | 7 | vdds | NA | 4 | PU100/ PD100 | LVC MOS |
| | | gpio_84 | 4 | IO | | | | | | | | |
| | | safe_mode | 7 | - | | | | | | | | |
| AB26 | NA | dss_data15 | 0 | IO | L | L | 7 | vdds | NA | 4 | PU100/ PD100 | LVC MOS |
| | | gpio_85 | 4 | IO | | | | | | | | |
| | | safe_mode | 7 | - | | | | | | | | |
| F25 | NA | dss_data20 | 0 | O | H | H | 7 | vdds | Yes | 4 | PU100/ PD100 | LVC MOS |
| | | mcs pi3_som i | 2 | IO | | | | | | | | |
| | | dss_data2 | 3 | IO | | | | | | | | |
| | | gpio_90 | 4 | IO | | | | | | | | |
| | | safe_mode | 7 | - | | | | | | | | |
| AC25 | NA | dss_data22 | 0 | O | L | L | 7 | vdds | NA | 4 | PU100/ PD100 | LVC MOS |
| | | mcs pi3_cs1 | 2 | O | | | | | | | | |
| | | dss_data4 | 3 | IO | | | | | | | | |
| | | gpio_92 | 4 | IO | | | | | | | | |
| | | safe_mode | 7 | - | | | | | | | | |
| AB25 | NA | dss_data23 | 0 | O | L | L | 7 | vdds | NA | 4 | PU100/ PD100 | LVC MOS |
| | | dss_data5 | 3 | IO | | | | | | | | |
| | | gpio_93 | 4 | IO | | | | | | | | |
| | | safe_mode | 7 | - | | | | | | | | |
| G25 | NA | dss_pclk | 0 | O | H | H | 7 | vdds | Yes | 4 | PU100/ PD100 | LVC MOS |
| | | gpio_66 | 4 | IO | | | | | | | | |
| | | hw_dbg12 | 5 | O | | | | | | | | |
| | | safe_mode | 7 | - | | | | | | | | |
| J2 | NA | gpmc_a1 | 0 | O | L | L | 7 | vdds | Yes | 4 ⁽²⁾ | PU100/ PD100 | LVC MOS |
| | | gpio_34 | 4 | IO | | | | | | | | |
| | | safe_mode | 7 | - | | | | | | | | |
| H1 | NA | gpmc_a2 | 0 | O | L | L | 7 | vdds | Yes | 4 ⁽²⁾ | PU100/ PD100 | LVC MOS |
| | | gpio_35 | 4 | IO | | | | | | | | |
| | | safe_mode | 7 | - | | | | | | | | |
| H2 | NA | gpmc_a3 | 0 | O | L | L | 7 | vdds | Yes | 4 ⁽²⁾ | PU100/ PD100 | LVC MOS |
| | | gpio_36 | 4 | IO | | | | | | | | |
| | | safe_mode | 7 | - | | | | | | | | |
| G2 | NA | gpmc_a4 | 0 | O | L | L | 7 | vdds | Yes | 4 ⁽²⁾ | PU100/ PD100 | LVC MOS |
| | | gpio_37 | 4 | IO | | | | | | | | |
| | | safe_mode | 7 | - | | | | | | | | |
| F1 | NA | gpmc_a5 | 0 | O | L | L | 7 | vdds | Yes | 4 ⁽²⁾ | PU100/ PD100 | LVC MOS |
| | | gpio_38 | 4 | IO | | | | | | | | |

Table 2-2. Ball Characteristics (CBC Pkg.) (continued)

| BALL BOTTOM [1] | BALL TOP [2] | PIN NAME [3] | MODE [4] | TYPE [5] | BALL RESET STATE [6] | BALL RESET REL. STATE [7] | RESET REL. MODE [8] | POWER [9] | HYS [10] | BUFFER STRENGTH (mA) [11] | PULLUP /DOWN TYPE [12] | IO CELL [13] |
|-----------------|--------------|------------------|----------|----------|----------------------|---------------------------|---------------------|-----------|----------|---------------------------|------------------------|--------------|
| | | safe_mode | 7 | - | | | | | | | | |
| F2 | NA | gpmc_a6 | 0 | O | H | H | 7 | vdds | Yes | 4 ⁽²⁾ | PU100/ PD100 | LVCMOS |
| | | gpio_39 | 4 | IO | | | | | | | | |
| | | safe_mode | 7 | - | | | | | | | | |
| E1 | NA | gpmc_a7 | 0 | O | H | H | 7 | vdds | Yes | 4 ⁽²⁾ | PU100/ PD100 | LVCMOS |
| | | gpio_40 | 4 | IO | | | | | | | | |
| | | safe_mode | 7 | - | | | | | | | | |
| E2 | NA | gpmc_a8 | 0 | O | H | H | 7 | vdds | Yes | 4 ⁽²⁾ | PU100/ PD100 | LVCMOS |
| | | gpio_41 | 4 | IO | | | | | | | | |
| | | safe_mode | 7 | - | | | | | | | | |
| D1 | NA | gpmc_a9 | 0 | O | H | H | 7 | vdds | Yes | 4 ⁽²⁾ | PU100/ PD100 | LVCMOS |
| | | sys_ndmareq 2 | 1 | I | | | | | | | | |
| | | gpio_42 | 4 | IO | | | | | | | | |
| | | safe_mode | 7 | - | | | | | | | | |
| D2 | NA | gpmc_a10 | 0 | O | H | H | 7 | vdds | Yes | 4 ⁽²⁾ | PU100/ PD100 | LVCMOS |
| | | sys_ndmareq 3 | 1 | I | | | | | | | | |
| | | gpio_43 | 4 | IO | | | | | | | | |
| | | safe_mode | 7 | - | | | | | | | | |
| N1 | L1 | gpmc_clk | 0 | O | L | 0 | 0 | vdds | Yes | 4 ⁽²⁾ | PU100/ PD100 | LVCMOS |
| | | gpio_59 | 4 | IO | | | | | | | | |
| | | safe_mode | 7 | - | | | | | | | | |
| AA2 | U2 | gpmc_d0 | 0 | IO | H | H | 0 | vdds | Yes | 4 ⁽²⁾ | PU100/ PD100 | LVCMOS |
| AA1 | U1 | gpmc_d1 | 0 | IO | H | H | 0 | vdds | Yes | 4 ⁽²⁾ | PU100/ PD100 | LVCMOS |
| AC2 | V2 | gpmc_d2 | 0 | IO | H | H | 0 | vdds | Yes | 4 ⁽²⁾ | PU100/ PD100 | LVCMOS |
| AC1 | V1 | gpmc_d3 | 0 | IO | H | H | 0 | vdds | Yes | 4 ⁽²⁾ | PU100/ PD100 | LVCMOS |
| AE5 | AA3 | gpmc_d4 | 0 | IO | H | H | 0 | vdds | Yes | 4 ⁽²⁾ | PU100/ PD100 | LVCMOS |
| AD6 | AA4 | gpmc_d5 | 0 | IO | H | H | 0 | vdds | Yes | 4 ⁽²⁾ | PU100/ PD100 | LVCMOS |
| AD5 | Y3 | gpmc_d6 | 0 | IO | H | H | 0 | vdds | Yes | 4 ⁽²⁾ | PU100/ PD100 | LVCMOS |
| AC5 | Y4 | gpmc_d7 | 0 | IO | H | H | 0 | vdds | Yes | 4 ⁽²⁾ | PU100/ PD100 | LVCMOS |
| V1 | R1 | gpmc_d8 | 0 | IO | H | H | 0 | vdds | Yes | 4 ⁽²⁾ | PU100/ PD100 | LVCMOS |
| | | gpio_44 | 4 | IO | | | | | | | | |
| | | safe_mode | 7 | - | | | | | | | | |
| Y1 | T1 | gpmc_d9 | 0 | IO | H | H | 0 | vdds | Yes | 4 ⁽²⁾ | PU100/ PD100 | LVCMOS |
| | | gpio_45 | 4 | IO | | | | | | | | |
| | | safe_mode | 7 | - | | | | | | | | |
| T1 | N1 | gpmc_d10 | 0 | IO | H | H | 0 | vdds | Yes | 4 ⁽²⁾ | PU100/ PD100 | LVCMOS |
| | | gpio_46 | 4 | IO | | | | | | | | |
| | | safe_mode | 7 | - | | | | | | | | |
| U2 | P2 | gpmc_d11 | 0 | IO | H | H | 0 | vdds | Yes | 4 ⁽²⁾ | PU100/ PD100 | LVCMOS |
| | | gpio_47 | 4 | IO | | | | | | | | |
| | | safe_mode | 7 | - | | | | | | | | |

Table 2-2. Ball Characteristics (CBC Pkg.) (continued)

| BALL BOTTOM [1] | BALL TOP [2] | PIN NAME [3] | MODE [4] | TYPE [5] | BALL RESET STATE [6] | BALL RESET REL. STATE [7] | RESET REL. MODE [8] | POWER [9] | HYS [10] | BUFFER STRENGTH (mA) [11] | PULLUP /DOWN TYPE [12] | IO CELL [13] |
|-----------------|--------------|---------------|----------|----------|----------------------|---------------------------|---------------------|-----------|----------|---------------------------|------------------------|--------------|
| U1 | P1 | gpmc_d12 | 0 | IO | H | H | 0 | vdds | Yes | 4 ⁽²⁾ | PU100/ PD100 | LVCMOS |
| | | gpio_48 | 4 | IO | | | | | | | | |
| | | safe_mode | 7 | - | | | | | | | | |
| P1 | M1 | gpmc_d13 | 0 | IO | H | H | 0 | vdds | Yes | 4 ⁽²⁾ | PU100/ PD100 | LVCMOS |
| | | gpio_49 | 4 | IO | | | | | | | | |
| | | safe_mode | 7 | - | | | | | | | | |
| L2 | J2 | gpmc_d14 | 0 | IO | H | H | 0 | vdds | Yes | 4 ⁽²⁾ | PU100/ PD100 | LVCMOS |
| | | gpio_50 | 4 | IO | | | | | | | | |
| | | safe_mode | 7 | - | | | | | | | | |
| M2 | K2 | gpmc_d15 | 0 | IO | H | H | 0 | vdds | Yes | 4 ⁽²⁾ | PU100/ PD100 | LVCMOS |
| | | gpio_51 | 4 | IO | | | | | | | | |
| | | safe_mode | 7 | - | | | | | | | | |
| AD10 | AA9 | gpmc_nadv_ale | 0 | O | 0 | 0 | 0 | vdds | No | 4 ⁽²⁾ | NA | LVCMOS |
| K2 | NA | gpmc_nbe0_cle | 0 | O | L | 0 | 0 | vdds | Yes | 4 ⁽²⁾ | PU100/ PD100 | LVCMOS |
| | | gpio_60 | 4 | IO | | | | | | | | |
| | | safe_mode | 7 | - | | | | | | | | |
| J1 | NA | gpmc_nbe1 | 0 | O | L | L | 7 | vdds | Yes | 4 ⁽²⁾ | PU100/ PD100 | LVCMOS |
| | | gpio_61 | 4 | IO | | | | | | | | |
| | | safe_mode | 7 | - | | | | | | | | |
| AD8 | AA8 | gpmc_ncs0 | 0 | O | 1 | 1 | 0 | vdds | No | 4 ⁽²⁾ | NA | LVCMOS |
| AD1 | W1 | gpmc_ncs1 | 0 | O | H | 1 | 0 | vdds | Yes | 4 ⁽²⁾ | PU100/ PD100 | LVCMOS |
| | | gpio_52 | 4 | IO | | | | | | | | |
| | | safe_mode | 7 | - | | | | | | | | |
| A3 | NA | gpmc_ncs2 | 0 | O | H | H | 7 | vdds | Yes | 4 ⁽²⁾ | PU100/ PD100 | LVCMOS |
| | | gpio_53 | 4 | IO | | | | | | | | |
| | | safe_mode | 7 | - | | | | | | | | |
| B6 | NA | gpmc_ncs3 | 0 | O | H | H | 7 | vdds | Yes | 4 ⁽²⁾ | PU100/ PD100 | LVCMOS |
| | | sys_ndmareq_0 | 1 | I | | | | | | | | |
| | | gpio_54 | 4 | IO | | | | | | | | |
| | | safe_mode | 7 | - | | | | | | | | |
| B4 | NA | gpmc_ncs4 | 0 | O | H | H | 7 | vdds | Yes | 4 ⁽²⁾ | PU100/ PD100 | LVCMOS |
| | | sys_ndmareq_1 | 1 | I | | | | | | | | |
| | | mcbasp4_clkx | 2 | IO | | | | | | | | |
| | | gpt9_pwm_evt | 3 | IO | | | | | | | | |
| | | gpio_55 | 4 | IO | | | | | | | | |
| | | safe_mode | 7 | - | | | | | | | | |
| C4 | NA | gpmc_ncs5 | 0 | O | H | H | 7 | vdds | Yes | 4 ⁽²⁾ | PU100/ PD100 | LVCMOS |
| | | sys_ndmareq_2 | 1 | I | | | | | | | | |
| | | mcbasp4_dr | 2 | I | | | | | | | | |
| | | gpt10_pwm_evt | 3 | IO | | | | | | | | |
| | | gpio_56 | 4 | IO | | | | | | | | |
| | | safe_mode | 7 | - | | | | | | | | |
| B5 | NA | gpmc_ncs6 | 0 | O | H | H | 7 | vdds | Yes | 4 ⁽²⁾ | PU100/ PD100 | LVCMOS |

Table 2-2. Ball Characteristics (CBC Pkg.) (continued)

| BALL BOTTOM [1] | BALL TOP [2] | PIN NAME [3] | MODE [4] | TYPE [5] | BALL RESET STATE [6] | BALL RESET REL. STATE [7] | RESET REL. MODE [8] | POWER [9] | HYS [10] | BUFFER STRENGTH (mA) [11] | PULLUP /DOWN TYPE [12] | IO CELL [13] |
|-----------------|--------------|---------------|----------|----------|----------------------|---------------------------|---------------------|-----------|----------|---------------------------|------------------------|--------------|
| | | sys_ndmareq3 | 1 | I | | | | | | | | |
| | | mcbasp4_dx | 2 | IO | | | | | | | | |
| | | gpt11_pwm_evt | 3 | IO | | | | | | | | |
| | | gpio_57 | 4 | IO | | | | | | | | |
| | | safe_mode | 7 | - | | | | | | | | |
| C5 | NA | gpmc_ncs7 | 0 | O | H | H | 7 | vdds | Yes | 4 ⁽²⁾ | PU100/ PD100 | LVC MOS |
| | | gpmc_io_dir | 1 | O | | | | | | | | |
| | | mcbasp4_fsx | 2 | IO | | | | | | | | |
| | | gpt8_pwm_evt | 3 | IO | | | | | | | | |
| | | gpio_58 | 4 | IO | | | | | | | | |
| | | safe_mode | 7 | - | | | | | | | | |
| N2 | L2 | gpmc_noe | 0 | O | 1 | 1 | 0 | vdds | No | 4 ⁽²⁾ | NA | LVC MOS |
| M1 | K1 | gpmc_nwe | 0 | O | 1 | 1 | 0 | vdds | No | 4 ⁽²⁾ | NA | LVC MOS |
| AC6 | Y5 | gpmc_nwp | 0 | O | L | 0 | 0 | vdds | Yes | 4 ⁽²⁾ | PU100/ PD100 | LVC MOS |
| | | gpio_62 | 4 | IO | | | | | | | | |
| | | safe_mode | 7 | - | | | | | | | | |
| AC11 | Y10 | gpmc_wait0 | 0 | I | H | H | 0 | vdds | Yes | 4 ⁽²⁾ | PU100/ PD100 | LVC MOS |
| AC8 | Y8 | gpmc_wait1 | 0 | I | H | H | 7 | vdds | Yes | 4 ⁽²⁾ | PU100/ PD100 | LVC MOS |
| | | gpio_63 | 4 | IO | | | | | | | | |
| | | safe_mode | 7 | - | | | | | | | | |
| B3 | NA | gpmc_wait2 | 0 | I | H | H | 7 | vdds | Yes | 4 ⁽²⁾ | PU100/ PD100 | LVC MOS |
| | | gpio_64 | 4 | IO | | | | | | | | |
| | | safe_mode | 7 | - | | | | | | | | |
| C6 | NA | gpmc_wait3 | 0 | I | H | H | 7 | vdds | Yes | 4 ⁽²⁾ | PU100/ PD100 | LVC MOS |
| | | sys_ndmareq1 | 1 | I | | | | | | | | |
| | | gpio_65 | 4 | IO | | | | | | | | |
| | | safe_mode | 7 | - | | | | | | | | |
| W19 | NA | hsusb0_clk | 0 | I | L | L | 7 | vdds | Yes | 4 ⁽³⁾ | PU100/ PD100 | LVC MOS |
| | | gpio_120 | 4 | IO | | | | | | | | |
| | | safe_mode | 7 | - | | | | | | | | |
| V20 | NA | hsusb0_data0 | 0 | IO | L | L | 7 | vdds | Yes | 4 ⁽³⁾ | PU100/ PD100 | LVC MOS |
| | | uart3_tx_irtx | 2 | O | | | | | | | | |
| | | gpio_125 | 4 | IO | | | | | | | | |
| | | safe_mode | 7 | - | | | | | | | | |
| Y20 | NA | hsusb0_data1 | 0 | IO | L | L | 7 | vdds | Yes | 4 ⁽³⁾ | PU100/ PD100 | LVC MOS |
| | | uart3_rx_irrx | 2 | I | | | | | | | | |
| | | gpio_130 | 4 | IO | | | | | | | | |
| | | safe_mode | 7 | - | | | | | | | | |
| V18 | NA | hsusb0_data2 | 0 | IO | L | L | 7 | vdds | Yes | 4 ⁽³⁾ | PU100/ PD100 | LVC MOS |
| | | uart3_rts_sd | 2 | O | | | | | | | | |
| | | gpio_131 | 4 | IO | | | | | | | | |
| | | safe_mode | 7 | - | | | | | | | | |
| W20 | NA | hsusb0_data3 | 0 | IO | L | L | 7 | vdds | Yes | 4 ⁽³⁾ | PU100/ PD100 | LVC MOS |

(3) The capacity load range is [2 pf to 6 pF].

Table 2-2. Ball Characteristics (CBC Pkg.) (continued)

| BALL BOTTOM [1] | BALL TOP [2] | PIN NAME [3] | MODE [4] | TYPE [5] | BALL RESET STATE [6] | BALL RESET REL. STATE [7] | RESET REL. MODE [8] | POWER [9] | HYS [10] | BUFFER STRENGTH (mA) [11] | PULLUP /DOWN TYPE [12] | IO CELL [13] |
|-----------------|--------------|--------------------|----------|----------|----------------------|---------------------------|---------------------|-----------|----------|---------------------------|------------------------|--------------|
| | | uart3_cts_rct x | 2 | IO | | | | | | | | |
| | | gpio_169 | 4 | IO | | | | | | | | |
| | | safe_mode | 7 | - | | | | | | | | |
| W17 | NA | hsusb0_data 4 | 0 | IO | L | L | 7 | vdds | Yes | 4 ⁽³⁾ | PU100/ PD100 | LVC MOS |
| | | gpio_188 | 4 | IO | | | | | | | | |
| | | safe_mode | 7 | - | | | | | | | | |
| Y18 | NA | hsusb0_data 5 | 0 | IO | L | L | 7 | vdds | Yes | 4 ⁽³⁾ | PU100/ PD100 | LVC MOS |
| | | gpio_189 | 4 | IO | | | | | | | | |
| | | safe_mode | 7 | - | | | | | | | | |
| Y19 | NA | hsusb0_data 6 | 0 | IO | L | L | 7 | vdds | Yes | 4 ⁽³⁾ | PU100/ PD100 | LVC MOS |
| | | gpio_190 | 4 | IO | | | | | | | | |
| | | safe_mode | 7 | - | | | | | | | | |
| Y17 | NA | hsusb0_data 7 | 0 | IO | L | L | 7 | vdds | Yes | 4 ⁽³⁾ | PU100/ PD100 | LVC MOS |
| | | gpio_191 | 4 | IO | | | | | | | | |
| | | safe_mode | 7 | - | | | | | | | | |
| V19 | NA | hsusb0_dir | 0 | I | L | L | 7 | vdds | Yes | 4 ⁽³⁾ | PU100/ PD100 | LVC MOS |
| | | gpio_122 | 4 | IO | | | | | | | | |
| | | safe_mode | 7 | - | | | | | | | | |
| W18 | NA | hsusb0_nxt | 0 | I | L | L | 7 | vdds | Yes | 4 ⁽³⁾ | PU100/ PD100 | LVC MOS |
| | | gpio_124 | 4 | IO | | | | | | | | |
| | | safe_mode | 7 | - | | | | | | | | |
| U20 | NA | hsusb0_stp | 0 | O | H | H | 7 | vdds | Yes | 4 ⁽³⁾ | PU100/ PD100 | LVC MOS |
| | | gpio_121 | 4 | IO | | | | | | | | |
| | | safe_mode | 7 | - | | | | | | | | |
| U15 | NA | jtag_ntrst | 0 | I | L | L | 0 | vdds | Yes | NA | PU100/ PD100 | LVC MOS |
| W13 | NA | jtag_rtck | 0 | O | L | 0 | 0 | vdds | Yes | 4 | PU100/ PD100 | LVC MOS |
| V14 | NA | jtag_tck | 0 | I | L | L | 0 | vdds | Yes | NA | PU100/ PD100 | LVC MOS |
| U16 | NA | jtag_tdi | 0 | I | H | H | 0 | vdds | Yes | NA | PU100/ PD100 | LVC MOS |
| Y13 | NA | jtag_tdo | 0 | O | L | Z | 0 | vdds | Yes | 4 | PU100/ PD100 | LVC MOS |
| V15 | NA | jtag_tms_tms c | 0 | IO | H | H | 0 | vdds | Yes | 4 | PU100/ PD100 | LVC MOS |
| N19 | NA | mmc1_clk | 0 | O | L | L | 7 | vdds_mmc1 | Yes | 8 | PU100/ PD100 | LVC MOS |
| | | gpio_120 | 4 | IO | | | | | | | | |
| | | safe_mode | 7 | - | | | | | | | | |
| L18 | NA | mmc1_cmd | 0 | IO | L | L | 7 | vdds_mmc1 | Yes | 8 | PU100/ PD100 | LVC MOS |
| | | gpio_121 | 4 | IO | | | | | | | | |
| | | safe_mode | 7 | - | | | | | | | | |
| M19 | NA | mmc1_dat0 | 0 | IO | L | L | 7 | vdds_mmc1 | Yes | 8 | PU100/ PD100 | LVC MOS |
| | | gpio_122 | 4 | IO | | | | | | | | |
| | | safe_mode | 7 | - | | | | | | | | |
| M18 | NA | mmc1_dat1 | 0 | IO | L | L | 7 | vdds_mmc1 | Yes | 8 | PU100/ PD100 | LVC MOS |
| | | gpio_123 | 4 | IO | | | | | | | | |
| | | safe_mode | 7 | - | | | | | | | | |

Table 2-2. Ball Characteristics (CBC Pkg.) (continued)

| BALL BOTTOM [1] | BALL TOP [2] | PIN NAME [3] | MODE [4] | TYPE [5] | BALL RESET STATE [6] | BALL RESET REL. STATE [7] | RESET REL. MODE [8] | POWER [9] | HYS [10] | BUFFER STRENGTH (mA) [11] | PULLUP /DOWN TYPE [12] | IO CELL [13] |
|-----------------|--------------|--------------|----------|----------|----------------------|---------------------------|---------------------|------------|----------|---------------------------|------------------------|--------------|
| K18 | NA | mmc1_dat2 | 0 | IO | L | L | 7 | vdds_mmc1 | Yes | 8 | PU100/ PD100 | LVCMOS |
| | | gpio_124 | 4 | IO | | | | | | | | |
| | | safe_mode | 7 | - | | | | | | | | |
| N20 | NA | mmc1_dat3 | 0 | IO | L | L | 7 | vdds_mmc1 | Yes | 8 | PU100/ PD100 | LVCMOS |
| | | gpio_125 | 4 | IO | | | | | | | | |
| | | safe_mode | 7 | - | | | | | | | | |
| M20 | NA | mmc1_dat4 | 0 | IO | L | L | 7 | vdds_mmc1a | No | 8 | PU/PD ⁽⁴⁾ | LVCMOS |
| | | gpio_126 | 4 | IO | | | | | | | | |
| | | safe_mode | 7 | - | | | | | | | | |
| P17 | NA | mmc1_dat5 | 0 | IO | L | L | 7 | vdds_mmc1a | No | 8 | PU/PD ⁽⁴⁾ | LVCMOS |
| | | gpio_127 | 4 | IO | | | | | | | | |
| | | safe_mode | 7 | - | | | | | | | | |
| P18 | NA | mmc1_dat6 | 0 | IO | L | L | 7 | vdds_mmc1a | No | 8 | PU/PD ⁽⁴⁾ | LVCMOS |
| | | gpio_128 | 4 | IO | | | | | | | | |
| | | safe_mode | 7 | - | | | | | | | | |
| P19 | NA | mmc1_dat7 | 0 | IO | L | L | 7 | vdds_mmc1a | No | 8 | PU/PD ⁽⁴⁾ | LVCMOS |
| | | gpio_129 | 4 | IO | | | | | | | | |
| | | safe_mode | 7 | - | | | | | | | | |
| J25 | NA | i2c1_scl | 0 | IOD | H | H | 0 | vdds | Yes | 3 | PU100/ PD100 | Open Drain |
| J24 | NA | i2c1_sda | 0 | IOD | H | H | 0 | vdds | Yes | 3 | PU100/ PD100 | Open Drain |
| C2 | NA | i2c2_scl | 0 | IOD | H | H | 7 | vdds | Yes | 3 | PU100/ PD100 | Open Drain |
| | | gpio_168 | 4 | IO | | | | | | | | |
| | | safe_mode | 7 | - | | | | | | | | |
| C1 | NA | i2c2_sda | 0 | IOD | H | H | 7 | vdds | Yes | 3 | PU100/ PD100 | Open Drain |
| | | gpio_183 | 4 | IO | | | | | | | | |
| | | safe_mode | 7 | - | | | | | | | | |
| AB4 | NA | i2c3_scl | 0 | IOD | H | H | 7 | vdds | Yes | 3 | PU100/ PD100 | Open Drain |
| | | gpio_184 | 4 | IO | | | | | | | | |
| | | safe_mode | 7 | - | | | | | | | | |
| AC4 | NA | i2c3_sda | 0 | IOD | H | H | 7 | vdds | Yes | 3 | PU100/ PD100 | Open Drain |
| | | gpio_185 | 4 | IO | | | | | | | | |
| | | safe_mode | 7 | - | | | | | | | | |
| U19 | NA | mcbasp1_clkr | 0 | IO | L | L | 7 | vdds | Yes | 4 ⁽³⁾ | PU100/ PD100 | LVCMOS |
| | | mcspi4_clk | 1 | IO | | | | | | | | |
| | | gpio_156 | 4 | IO | | | | | | | | |
| | | safe_mode | 7 | - | | | | | | | | |
| T17 | NA | mcbasp1_clkx | 0 | IO | L | L | 7 | vdds | Yes | 4 ⁽³⁾ | PU100/ PD100 | LVCMOS |
| | | mcbasp3_clkx | 2 | IO | | | | | | | | |
| | | gpio_162 | 4 | IO | | | | | | | | |
| | | safe_mode | 7 | - | | | | | | | | |
| T20 | NA | mcbasp1_dr | 0 | I | L | L | 7 | vdds | Yes | 4 ⁽³⁾ | PU100/ PD100 | LVCMOS |
| | | mcspi4_somi | 1 | IO | | | | | | | | |
| | | mcbasp3_dr | 2 | I | | | | | | | | |
| | | gpio_159 | 4 | IO | | | | | | | | |
| | | safe_mode | 7 | - | | | | | | | | |

(4) The PU nominal drive strength of this IO cell is equal to 25 mA @ 1.8 V and 41.6 mA @ 3.0 V. The PD nominal drive strength of this IO cell is equal to 1 mA @ 1.8 V and 1.66 mA @ 3.0 V.

Table 2-2. Ball Characteristics (CBC Pkg.) (continued)

| BALL BOTTOM [1] | BALL TOP [2] | PIN NAME [3] | MODE [4] | TYPE [5] | BALL RESET STATE [6] | BALL RESET REL. STATE [7] | RESET REL. MODE [8] | POWER [9] | HYS [10] | BUFFER STRENGTH (mA) [11] | PULLUP /DOWN TYPE [12] | IO CELL [13] |
|-----------------|--------------|-----------------------|----------|----------|----------------------|---------------------------|---------------------|-----------|----------|---------------------------|------------------------|--------------|
| U17 | NA | mcbasp1_dx | 0 | IO | L | L | 7 | vdds | Yes | 4 ⁽⁵⁾ | PU100/ PD100 | LVCMOS |
| | | mcspi4_simo | 1 | IO | | | | | | | | |
| | | mcbasp3_dx | 2 | IO | | | | | | | | |
| | | gpio_158 | 4 | IO | | | | | | | | |
| | | safe_mode | 7 | - | | | | | | | | |
| V17 | NA | mcbasp1_fsr | 0 | IO | L | L | 7 | vdds | Yes | 4 ⁽⁵⁾ | PU100/ PD100 | LVCMOS |
| | | cam_global_r reset | 2 | IO | | | | | | | | |
| | | gpio_157 | 4 | IO | | | | | | | | |
| | | safe_mode | 7 | - | | | | | | | | |
| P20 | NA | mcbasp1_fsx | 0 | IO | L | L | 7 | vdds | Yes | 4 ⁽⁵⁾ | PU100/ PD100 | LVCMOS |
| | | mcspi4_cs0 | 1 | IO | | | | | | | | |
| | | mcbasp3_fsx | 2 | IO | | | | | | | | |
| | | gpio_161 | 4 | IO | | | | | | | | |
| | | safe_mode | 7 | - | | | | | | | | |
| R18 | NA | mcbasp2_clkx | 0 | IO | L | L | 7 | vdds | Yes | 4 ⁽⁵⁾ | PU100/ PD100 | LVCMOS |
| | | gpio_117 | 4 | IO | | | | | | | | |
| | | safe_mode | 7 | - | | | | | | | | |
| T18 | NA | mcbasp2_dr | 0 | I | L | L | 7 | vdds | Yes | 4 ⁽⁵⁾ | PU100/ PD100 | LVCMOS |
| | | gpio_118 | 4 | IO | | | | | | | | |
| | | safe_mode | 7 | - | | | | | | | | |
| R19 | NA | mcbasp2_dx | 0 | IO | L | L | 7 | vdds | Yes | 4 ⁽⁵⁾ | PU100/ PD100 | LVCMOS |
| | | gpio_119 | 4 | IO | | | | | | | | |
| | | safe_mode | 7 | - | | | | | | | | |
| U18 | NA | mcbasp2_fsx | 0 | IO | L | L | 7 | vdds | Yes | 4 ⁽⁵⁾ | PU100/ PD100 | LVCMOS |
| | | gpio_116 | 4 | IO | | | | | | | | |
| | | safe_mode | 7 | - | | | | | | | | |
| P9 | NA | mcspi1_clk | 0 | IO | L | L | 7 | vdds | Yes | 4 ⁽⁵⁾ | PU100/ PD100 | LVCMOS |
| | | mmc2_dat4 | 1 | IO | | | | | | | | |
| | | gpio_171 | 4 | IO | | | | | | | | |
| | | safe_mode | 7 | - | | | | | | | | |
| R7 | NA | mcspi1_cs0 | 0 | IO | H | H | 7 | vdds | Yes | 4 ⁽⁵⁾ | PU100/ PD100 | LVCMOS |
| | | mmc2_dat7 | 1 | IO | | | | | | | | |
| | | gpio_174 | 4 | IO | | | | | | | | |
| | | safe_mode | 7 | - | | | | | | | | |
| R9 | NA | mcspi1_cs2 | 0 | O | H | H | 7 | vdds | Yes | 4 ⁽⁵⁾ | PU100/ PD100 | LVCMOS |
| | | mmc3_clk | 3 | O | | | | | | | | |
| | | gpio_176 | 4 | IO | | | | | | | | |
| | | safe_mode | 7 | - | | | | | | | | |
| P8 | NA | mcspi1_simo | 0 | IO | L | L | 7 | vdds | Yes | 4 ⁽⁵⁾ | PU100/ PD100 | LVCMOS |
| | | mmc2_dat5 | 1 | IO | | | | | | | | |
| | | gpio_172 | 4 | IO | | | | | | | | |
| | | safe_mode | 7 | - | | | | | | | | |
| P7 | NA | mcspi1_somii | 0 | IO | L | L | 7 | vdds | Yes | 4 ⁽⁵⁾ | PU100/ PD100 | LVCMOS |
| | | mmc2_dat6 | 1 | IO | | | | | | | | |

(5) The buffer strength of this IO cell is programmable (2, 4, 6, or 8 mA) according to the selected mode; the default value is described in the above table.

Table 2-2. Ball Characteristics (CBC Pkg.) (continued)

| BALL BOTTOM [1] | BALL TOP [2] | PIN NAME [3] | MODE [4] | TYPE [5] | BALL RESET STATE [6] | BALL RESET REL. STATE [7] | RESET REL. MODE [8] | POWER [9] | HYS [10] | BUFFER STRENGTH (mA) [11] | PULLUP /DOWN TYPE [12] | IO CELL [13] |
|-----------------|--------------|------------------|----------|----------|----------------------|---------------------------|---------------------|-----------|----------|---------------------------|------------------------|--------------|
| | | gpio_173 | 4 | IO | | | | | | | | |
| | | safe_mode | 7 | - | | | | | | | | |
| W7 | NA | mcspi2_clk | 0 | IO | L | L | 7 | vdds | Yes | 4 ⁽³⁾ | PU100/ PD100 | LVC MOS |
| | | hsusb2_tll_data7 | 2 | IO | | | | | | | | |
| | | hsusb2_data7 | 3 | O | | | | | | | | |
| | | gpio_178 | 4 | IO | | | | | | | | |
| | | safe_mode | 7 | - | | | | | | | | |
| V8 | NA | mcspi2_cs0 | 0 | IO | H | H | 7 | vdds | Yes | 4 ⁽³⁾ | PU100/ PD100 | LVC MOS |
| | | gpt11_pwm_evt | 1 | IO | | | | | | | | |
| | | hsusb2_tll_data6 | 2 | IO | | | | | | | | |
| | | hsusb2_data6 | 3 | O | | | | | | | | |
| | | gpio_181 | 4 | IO | | | | | | | | |
| | | safe_mode | 7 | - | | | | | | | | |
| W8 | NA | mcspi2_simo | 0 | IO | L | L | 7 | vdds | Yes | 4 ⁽³⁾ | PU100/ PD100 | LVC MOS |
| | | gpt9_pwm_evt | 1 | IO | | | | | | | | |
| | | hsusb2_tll_data4 | 2 | IO | | | | | | | | |
| | | hsusb2_data4 | 3 | I | | | | | | | | |
| | | gpio_179 | 4 | IO | | | | | | | | |
| | | safe_mode | 7 | - | | | | | | | | |
| U8 | NA | mcspi2_somi | 0 | IO | L | L | 7 | vdds | Yes | 4 ⁽³⁾ | PU100/ PD100 | LVC MOS |
| | | gpt10_pwm_evt | 1 | IO | | | | | | | | |
| | | hsusb2_tll_data5 | 2 | IO | | | | | | | | |
| | | hsusb2_data5 | 3 | O | | | | | | | | |
| | | gpio_180 | 4 | IO | | | | | | | | |
| | | safe_mode | 7 | - | | | | | | | | |
| W10 | NA | mmc2_clk | 0 | O | L | L | 7 | vdds | Yes | 4 ⁽³⁾ | PU100/ PD100 | LVC MOS |
| | | mcspi3_clk | 1 | IO | | | | | | | | |
| | | gpio_130 | 4 | IO | | | | | | | | |
| | | safe_mode | 7 | - | | | | | | | | |
| R10 | NA | mmc2_cmd | 0 | IO | H | H | 7 | vdds | Yes | 4 ⁽³⁾ | PU100/ PD100 | LVC MOS |
| | | mcspi3_simo | 1 | IO | | | | | | | | |
| | | gpio_131 | 4 | IO | | | | | | | | |
| | | safe_mode | 7 | - | | | | | | | | |
| T10 | NA | mmc2_dat0 | 0 | IO | H | H | 7 | vdds | Yes | 4 ⁽³⁾ | PU100/ PD100 | LVC MOS |
| | | mcspi3_somi | 1 | IO | | | | | | | | |
| | | gpio_132 | 4 | IO | | | | | | | | |
| | | safe_mode | 7 | - | | | | | | | | |
| T9 | NA | mmc2_dat1 | 0 | IO | H | H | 7 | vdds | Yes | 4 ⁽³⁾ | PU100/ PD100 | LVC MOS |
| | | gpio_133 | 4 | IO | | | | | | | | |
| | | safe_mode | 7 | - | | | | | | | | |
| U10 | NA | mmc2_dat2 | 0 | IO | H | H | 7 | vdds | Yes | 4 ⁽³⁾ | PU100/ PD100 | LVC MOS |
| | | mcspi3_cs1 | 1 | O | | | | | | | | |

Table 2-2. Ball Characteristics (CBC Pkg.) (continued)

| BALL BOTTOM [1] | BALL TOP [2] | PIN NAME [3] | MODE [4] | TYPE [5] | BALL RESET STATE [6] | BALL RESET REL. STATE [7] | RESET REL. MODE [8] | POWER [9] | HYS [10] | BUFFER STRENGTH (mA) [11] | PULLUP /DOWN TYPE [12] | IO CELL [13] |
|-----------------|--------------|-----------------|----------|----------|----------------------|---------------------------|---------------------|-----------|----------|---------------------------|------------------------|--------------|
| | | gpio_134 | 4 | IO | | | | | | | | |
| | | safe_mode | 7 | - | | | | | | | | |
| U9 | NA | mmc2_dat3 | 0 | IO | H | H | 7 | vdds | Yes | 4 ⁽³⁾ | PU100/ PD100 | LVC MOS |
| | | mcspi3_cs0 | 1 | IO | | | | | | | | |
| | | gpio_135 | 4 | IO | | | | | | | | |
| | | safe_mode | 7 | - | | | | | | | | |
| V10 | NA | mmc2_dat4 | 0 | IO | L | L | 7 | vdds | Yes | 4 ⁽³⁾ | PU100/ PD100 | LVC MOS |
| | | mmc2_dir_data0 | 1 | O | | | | | | | | |
| | | mmc3_dat0 | 3 | IO | | | | | | | | |
| | | gpio_136 | 4 | IO | | | | | | | | |
| | | safe_mode | 7 | - | | | | | | | | |
| R2 | NA | uart1_rts | 0 | O | L | L | 7 | vdds | Yes | 4 ⁽³⁾ | PU100/ PD100 | LVC MOS |
| | | gpio_149 | 4 | IO | | | | | | | | |
| | | safe_mode | 7 | - | | | | | | | | |
| H3 | NA | uart1_rx | 0 | I | L | L | 7 | vdds | Yes | 4 ⁽³⁾ | PU100/ PD100 | LVC MOS |
| | | mcbasp1_clkr | 2 | IO | | | | | | | | |
| | | mcspi4_clk | 3 | IO | | | | | | | | |
| | | gpio_151 | 4 | IO | | | | | | | | |
| | | safe_mode | 7 | - | | | | | | | | |
| L4 | NA | uart1_tx | 0 | O | L | L | 7 | vdds | Yes | 4 ⁽³⁾ | PU100/ PD100 | LVC MOS |
| | | gpio_148 | 4 | IO | | | | | | | | |
| | | safe_mode | 7 | - | | | | | | | | |
| Y24 | NA | uart2_cts | 0 | I | H | H | 7 | vdds | Yes | 4 | PU100/ PD100 | LVC MOS |
| | | mcbasp3_dx | 1 | IO | | | | | | | | |
| | | gpt9_pwm_event | 2 | IO | | | | | | | | |
| | | gpio_144 | 4 | IO | | | | | | | | |
| | | safe_mode | 7 | - | | | | | | | | |
| AA24 | NA | uart2_rts | 0 | O | H | H | 7 | vdds | Yes | 4 | PU100/ PD100 | LVC MOS |
| | | mcbasp3_dr | 1 | I | | | | | | | | |
| | | gpt10_pwm_event | 2 | IO | | | | | | | | |
| | | gpio_145 | 4 | IO | | | | | | | | |
| | | safe_mode | 7 | - | | | | | | | | |
| AD21 | NA | uart2_rx | 0 | I | H | H | 7 | vdds | Yes | 4 | PU100/ PD100 | LVC MOS |
| | | mcbasp3_fsx | 1 | IO | | | | | | | | |
| | | gpt8_pwm_event | 2 | IO | | | | | | | | |
| | | gpio_147 | 4 | IO | | | | | | | | |
| | | safe_mode | 7 | - | | | | | | | | |
| AD22 | NA | uart2_tx | 0 | O | H | H | 7 | vdds | Yes | 4 | PU100/ PD100 | LVC MOS |
| | | mcbasp3_clkx | 1 | IO | | | | | | | | |
| | | gpt11_pwm_event | 2 | IO | | | | | | | | |
| | | gpio_146 | 4 | IO | | | | | | | | |
| | | safe_mode | 7 | - | | | | | | | | |
| F23 | NA | uart3_cts_rtx | 0 | IO | H | H | 7 | vdds | Yes | 4 | PU100/ PD100 | LVC MOS |
| | | gpio_163 | 4 | IO | | | | | | | | |
| | | safe_mode | 7 | - | | | | | | | | |

Table 2-2. Ball Characteristics (CBC Pkg.) (continued)

| BALL BOTTOM [1] | BALL TOP [2] | PIN NAME [3] | MODE [4] | TYPE [5] | BALL RESET STATE [6] | BALL RESET REL. STATE [7] | RESET REL. MODE [8] | POWER [9] | HYS [10] | BUFFER STRENGTH (mA) [11] | PULLUP /DOWN TYPE [12] | IO CELL [13] |
|-----------------|--------------|-------------------|----------|----------|----------------------|---------------------------|---------------------|-----------|----------|---------------------------|------------------------|--------------|
| F24 | NA | uart3_rts_sd | 0 | O | H | H | 7 | vdds | Yes | 4 | PU100/ PD100 | LVCMOS |
| | | gpio_164 | 4 | IO | | | | | | | | |
| | | safe_mode | 7 | - | | | | | | | | |
| H24 | NA | uart3_rx_irrx | 0 | I | H | H | 7 | vdds | Yes | 4 | PU100/ PD100 | LVCMOS |
| | | gpio_165 | 4 | IO | | | | | | | | |
| | | safe_mode | 7 | - | | | | | | | | |
| G24 | NA | uart3_tx_irtx | 0 | O | H | H | 7 | vdds | Yes | 4 | PU100/ PD100 | LVCMOS |
| | | gpio_166 | 4 | IO | | | | | | | | |
| | | safe_mode | 7 | - | | | | | | | | |
| J23 | NA | hdq_sio | 0 | IOD | H | H | 7 | vdds | Yes | 4 | PU100/ PD100 | LVCMOS |
| | | sys_altclk | 1 | I | | | | | | | | |
| | | i2c2_sccbe | 2 | O | | | | | | | | |
| | | i2c3_sccbe | 3 | O | | | | | | | | |
| | | gpio_170 | 4 | IO | | | | | | | | |
| | | safe_mode | 7 | - | | | | | | | | |
| AD15 | NA | i2c4_scl | 0 | IOD | H | H | 0 | vdds | Yes | 3 | PU100/ PD100 | Open Drain |
| | | sys_nvmode 1 | 1 | O | | | | | | 4 | | |
| | | safe_mode | 7 | - | | | | | | 4 | | |
| W16 | NA | i2c4_sda | 0 | IOD | H | H | 0 | vdds | Yes | 3 | PU100/ PD100 | Open Drain |
| | | sys_nvmode 2 | 1 | O | | | | | | 4 | | |
| | | safe_mode | 7 | - | | | | | | 4 | | |
| F3 | NA | sys_boot0 | 0 | I | Z | Z | 0 | vdds | Yes | 4 | PU100/ PD100 | LVCMOS |
| | | gpio_2 | 4 | IO | | | | | | | | |
| | | safe_mode | 7 | - | | | | | | | | |
| D3 | NA | sys_boot1 | 0 | I | Z | Z | 0 | vdds | Yes | 4 | PU100/ PD100 | LVCMOS |
| | | gpio_3 | 4 | IO | | | | | | | | |
| | | safe_mode | 7 | - | | | | | | | | |
| C3 | NA | sys_boot2 | 0 | I | Z | Z | 0 | vdds | Yes | 4 | PU100/ PD100 | LVCMOS |
| | | gpio_4 | 4 | IO | | | | | | | | |
| | | safe_mode | 7 | - | | | | | | | | |
| E3 | NA | sys_boot3 | 0 | I | Z | Z | 0 | vdds | Yes | 4 | PU100/ PD100 | LVCMOS |
| | | gpio_5 | 4 | IO | | | | | | | | |
| | | safe_mode | 7 | - | | | | | | | | |
| E4 | NA | sys_boot4 | 0 | I | Z | Z | 0 | vdds | Yes | 4 | PU100/ PD100 | LVCMOS |
| | | mmc2_dir_da t2 | 1 | O | | | | | | | | |
| | | gpio_6 | 4 | IO | | | | | | | | |
| | | safe_mode | 7 | - | | | | | | | | |
| G3 | NA | sys_boot5 | 0 | I | Z | Z | 0 | vdds | Yes | 4 | PU100/ PD100 | LVCMOS |
| | | mmc2_dir_da t3 | 1 | O | | | | | | | | |
| | | gpio_7 | 4 | IO | | | | | | | | |
| | | safe_mode | 7 | - | | | | | | | | |
| D4 | NA | sys_boot6 | 0 | I | Z | Z | 0 | vdds | Yes | 4 | PU100/ PD100 | LVCMOS |
| | | gpio_8 | 4 | IO | | | | | | | | |
| | | safe_mode | 7 | - | | | | | | | | |

Table 2-2. Ball Characteristics (CBC Pkg.) (continued)

| BALL BOTTOM [1] | BALL TOP [2] | PIN NAME [3] | MODE [4] | TYPE [5] | BALL RESET STATE [6] | BALL RESET REL. STATE [7] | RESET REL. MODE [8] | POWER [9] | HYS [10] | BUFFER STRENGTH (mA) [11] | PULLUP /DOWN TYPE [12] | IO CELL [13] |
|-----------------|--------------|-------------------|----------|----------|----------------------|---------------------------|---------------------|-----------|----------|---------------------------|------------------------|--------------|
| AE14 | NA | sys_clkout1 | 0 | O | L | L | 7 | vdds | Yes | 4 | PU100/ PD100 | LVCMOS |
| | | gpio_10 | 4 | IO | | | | | | | | |
| | | safe_mode | 7 | - | | | | | | | | |
| W11 | NA | sys_clkout2 | 0 | O | L | L | 7 | vdds | Yes | 4 ⁽³⁾ | PU100/ PD100 | LVCMOS |
| | | gpio_186 | 4 | IO | | | | | | | | |
| | | safe_mode | 7 | - | | | | | | | | |
| W15 | NA | sys_clkreq | 0 | IO | 0 | 1 | 0 | vdds | Yes | 4 | PU100/ PD100 | LVCMOS |
| | | gpio_1 | 4 | IO | | | | | | | | |
| | | safe_mode | 7 | - | | | | | | | | |
| V16 | NA | sys_nirq | 0 | I | H | H | 7 | vdds | Yes | 4 | PU100/ PD100 | LVCMOS |
| | | gpio_0 | 4 | IO | | | | | | | | |
| | | safe_mode | 7 | - | | | | | | | | |
| V13 | NA | sys_nrespwr on | 0 | I | Z | I | NA | vdds | Yes | NA | NA | LVCMOS |
| AD7 | AA5 | sys_nreswar m | 0 | IOD | 0 | 1 (PU) | 0 | vdds | Yes | 4 | PU100/ PD100 | LVCMOS |
| | | gpio_30 | 4 | IO | | | | | | | | Open Drain |
| | | safe_mode | 7 | - | | | | | | | | |
| V12 | NA | sys_off_mod e | 0 | O | 0 | L | 7 | vdds | Yes | 4 | PU100/ PD100 | LVCMOS |
| | | gpio_9 | 4 | IO | | | | | | | | |
| | | safe_mode | 7 | - | | | | | | | | |
| AF19 | NA | sys_xtalin | 0 | I | Z | I | NA | vdds | Yes | NA | NA | LVCMOS |
| AF20 | NA | sys_xtalout | 0 | O | Z | O | NA | vdds | Yes | NA | NA | LVCMOS |
| W26 | NA | tv_out1 | 0 | AO | Z | 0 | 0 | vdda_dac | No | 8 | NA | 10-bit DAC |
| V26 | NA | tv_out2 | 0 | AO | Z | 0 | 0 | vdda_dac | No | 8 | NA | 10-bit DAC |
| W25 | NA | tv_vfb1 | 0 | O | Z | NA | 0 | vdda_dac | No | 2 | NA | 10-bit DAC |
| U24 | NA | tv_vfb2 | 0 | O | Z | NA | 0 | vdda_dac | No | 2 | NA | 10-bit DAC |
| V23 | NA | tv_vref | 0 | I | Z | NA | 0 | vdda_dac | No | NA | NA | 10-bit DAC |
| AE20 | NA | sys_32k | 0 | I | Z | I | NA | vdds | Yes | NA | NA | LVCMOS |
| A24 | NA | cam_d2 | 0 | I | L | L | 7 | vdds | Yes | 4 ⁽³⁾ | PU100/ PD100 | LVCMOS |
| | | gpio_101 | 4 | IO | | | | | | | | |
| | | hw_dbg4 | 5 | O | | | | | | | | |
| | | safe_mode | 7 | - | | | | | | | | |
| B24 | NA | cam_d3 | 0 | I | L | L | 7 | vdds | Yes | 4 ⁽³⁾ | PU100/ PD100 | LVCMOS |
| | | gpio_102 | 4 | IO | | | | | | | | |
| | | hw_dbg5 | 5 | O | | | | | | | | |
| | | safe_mode | 7 | - | | | | | | | | |
| D24 | NA | cam_d4 | 0 | I | L | L | 7 | vdds | Yes | 4 ⁽³⁾ | PU100/ PD100 | LVCMOS |
| | | gpio_103 | 4 | IO | | | | | | | | |
| | | hw_dbg6 | 5 | O | | | | | | | | |
| | | safe_mode | 7 | - | | | | | | | | |
| C24 | NA | cam_d5 | 0 | I | L | L | 7 | vdds | Yes | 4 ⁽³⁾ | PU100/ PD100 | LVCMOS |
| | | gpio_104 | 4 | IO | | | | | | | | |
| | | hw_dbg7 | 5 | O | | | | | | | | |
| | | safe_mode | 7 | - | | | | | | | | |
| D25 | NA | cam_d10 | 0 | I | L | L | 7 | vdds | Yes | 4 ⁽³⁾ | PU100/ PD100 | LVCMOS |
| | | gpio_109 | 4 | IO | | | | | | | | |
| | | hw_dbg8 | 5 | O | | | | | | | | |
| | | safe_mode | 7 | - | | | | | | | | |

Table 2-2. Ball Characteristics (CBC Pkg.) (continued)

| BALL BOTTOM [1] | BALL TOP [2] | PIN NAME [3] | MODE [4] | TYPE [5] | BALL RESET STATE [6] | BALL RESET REL. STATE [7] | RESET REL. MODE [8] | POWER [9] | HYS [10] | BUFFER STRENGTH (mA) [11] | PULLUP /DOWN TYPE [12] | IO CELL [13] |
|-----------------|--------------|-----------------------|----------|----------|----------------------|---------------------------|---------------------|-----------|----------|---------------------------|------------------------|--------------|
| E26 | NA | cam_d11 | 0 | I | L | L | 7 | vdds | Yes | 4 ⁽³⁾ | PU100/ PD100 | LVCMOS |
| | | gpio_110 | 4 | IO | | | | | | | | |
| | | hw_dbg9 | 5 | O | | | | | | | | |
| | | safe_mode | 7 | - | | | | | | | | |
| B23 | NA | cam_fld | 0 | IO | L | L | 7 | vdds | Yes | 4 ⁽³⁾ | PU100/ PD100 | LVCMOS |
| | | cam_global_r reset | 2 | IO | | | | | | | | |
| | | gpio_98 | 4 | IO | | | | | | | | |
| | | hw_dbg3 | 5 | O | | | | | | | | |
| | | safe_mode | 7 | - | | | | | | | | |
| C23 | NA | cam_hs | 0 | IO | L | L | 7 | vdds | Yes | 4 ⁽³⁾ | PU100/ PD100 | LVCMOS |
| | | gpio_94 | 4 | IO | | | | | | | | |
| | | hw_dbg0 | 5 | O | | | | | | | | |
| | | safe_mode | 7 | - | | | | | | | | |
| C26 | NA | cam_pclk | 0 | I | L | L | 7 | vdds | Yes | 4 ⁽³⁾ | PU100/ PD100 | LVCMOS |
| | | gpio_97 | 4 | IO | | | | | | | | |
| | | hw_dbg2 | 5 | O | | | | | | | | |
| | | safe_mode | 7 | - | | | | | | | | |
| D26 | NA | cam_strobe | 0 | O | L | L | 7 | vdds | Yes | 4 ⁽³⁾ | PU100/ PD100 | LVCMOS |
| | | gpio_126 | 4 | IO | | | | | | | | |
| | | hw_dbg11 | 5 | O | | | | | | | | |
| | | safe_mode | 7 | - | | | | | | | | |
| C25 | NA | cam_xclka | 0 | O | L | L | 7 | vdds | Yes | 4 ⁽³⁾ | PU100/ PD100 | LVCMOS |
| | | gpio_96 | 4 | IO | | | | | | | | |
| | | safe_mode | 7 | - | | | | | | | | |
| E25 | NA | cam_xclkb | 0 | O | L | L | 7 | vdds | Yes | 4 ⁽³⁾ | PU100/ PD100 | LVCMOS |
| | | gpio_111 | 4 | IO | | | | | | | | |
| | | safe_mode | 7 | - | | | | | | | | |
| P25 | NA | cam_d6 | 0 | I | L | L | 7 | vdds | NA | 4 | PU100/ PD100 | SubLVDS |
| | | gpio_105 | 4 | IO | | | | | | | | |
| | | safe_mode | 7 | - | | | | | | | | |
| P26 | NA | cam_d7 | 0 | I | L | L | 7 | vdds | NA | 4 | PU100/ PD100 | SubLVDS |
| | | gpio_106 | 4 | IO | | | | | | | | |
| | | safe_mode | 7 | - | | | | | | | | |
| N25 | NA | cam_d8 | 0 | I | L | L | 7 | vdds | NA | 4 | PU100/ PD100 | SubLVDS |
| | | gpio_107 | 4 | IO | | | | | | | | |
| | | safe_mode | 7 | - | | | | | | | | |
| N26 | NA | cam_d9 | 0 | I | L | L | 7 | vdds | NA | 4 | PU100/ PD100 | SubLVDS |
| | | gpio_108 | 4 | IO | | | | | | | | |
| | | safe_mode | 7 | - | | | | | | | | |
| D23 | NA | cam_vs | 0 | IO | L | L | 7 | vdds | Yes | 4 ⁽³⁾ | PU100/ PD100 | LVCMOS |
| | | gpio_95 | 4 | IO | | | | | | | | |
| | | hw_dbg1 | 5 | O | | | | | | | | |
| | | safe_mode | 7 | - | | | | | | | | |
| A23 | NA | cam_wen | 0 | I | L | L | 7 | vdds | Yes | 4 ⁽³⁾ | PU100/ PD100 | LVCMOS |
| | | cam_shutter | 2 | O | | | | | | | | |
| | | gpio_167 | 4 | IO | | | | | | | | |

Table 2-2. Ball Characteristics (CBC Pkg.) (continued)

| BALL BOTTOM [1] | BALL TOP [2] | PIN NAME [3] | MODE [4] | TYPE [5] | BALL RESET STATE [6] | BALL RESET REL. STATE [7] | RESET REL. MODE [8] | POWER [9] | HYS [10] | BUFFER STRENGTH (mA) [11] | PULLUP /DOWN TYPE [12] | IO CELL [13] |
|-----------------|--------------|--------------|----------|----------|----------------------|---------------------------|---------------------|-----------|----------|---------------------------|------------------------|--------------|
| | | hw_dbg10 | 5 | O | | | | | | | | |
| | | safe_mode | 7 | - | | | | | | | | |
| F26 | NA | dss_acbias | 0 | O | L | L | 7 | vdds | Yes | 8 | PU100/ PD100 | LVC MOS |
| | | gpio_69 | 4 | IO | | | | | | | | |
| | | safe_mode | 7 | - | | | | | | | | |
| G26 | NA | dss_data6 | 0 | IO | L | L | 7 | vdds | Yes | 8 | PU100/ PD100 | LVC MOS |
| | | uart1_tx | 2 | O | | | | | | | | |
| | | gpio_76 | 4 | IO | | | | | | | | |
| | | hw_dbg14 | 5 | O | | | | | | | | |
| | | safe_mode | 7 | - | | | | | | | | |
| H25 | NA | dss_data7 | 0 | IO | L | L | 7 | vdds | Yes | 8 | PU100/ PD100 | LVC MOS |
| | | uart1_rx | 2 | I | | | | | | | | |
| | | gpio_77 | 4 | IO | | | | | | | | |
| | | hw_dbg15 | 5 | O | | | | | | | | |
| | | safe_mode | 7 | - | | | | | | | | |
| H26 | NA | dss_data8 | 0 | IO | L | L | 7 | vdds | Yes | 8 | PU100/ PD100 | LVC MOS |
| | | gpio_78 | 4 | IO | | | | | | | | |
| | | hw_dbg16 | 5 | O | | | | | | | | |
| | | safe_mode | 7 | - | | | | | | | | |
| J26 | NA | dss_data9 | 0 | IO | L | L | 7 | vdds | Yes | 8 | PU100/ PD100 | LVC MOS |
| | | gpio_79 | 4 | IO | | | | | | | | |
| | | hw_dbg17 | 5 | O | | | | | | | | |
| | | safe_mode | 7 | - | | | | | | | | |
| L25 | NA | dss_data16 | 0 | IO | L | L | 7 | vdds | Yes | 8 | PU100/ PD100 | LVC MOS |
| | | gpio_86 | 4 | IO | | | | | | | | |
| | | safe_mode | 7 | - | | | | | | | | |
| L26 | NA | dss_data17 | 0 | IO | L | L | 7 | vdds | Yes | 8 | PU100/ PD100 | LVC MOS |
| | | gpio_87 | 4 | IO | | | | | | | | |
| | | safe_mode | 7 | - | | | | | | | | |
| M24 | NA | dss_data18 | 0 | IO | L | L | 7 | vdds | Yes | 8 | PU100/ PD100 | LVC MOS |
| | | mcspi3_clk | 2 | IO | | | | | | | | |
| | | dss_data0 | 3 | IO | | | | | | | | |
| | | gpio_88 | 4 | IO | | | | | | | | |
| | | safe_mode | 7 | - | | | | | | | | |
| M26 | NA | dss_data19 | 0 | IO | L | L | 7 | vdds | Yes | 8 | PU100/ PD100 | LVC MOS |
| | | mcspi3_simo | 2 | IO | | | | | | | | |
| | | dss_data1 | 3 | IO | | | | | | | | |
| | | gpio_89 | 4 | IO | | | | | | | | |
| | | safe_mode | 7 | - | | | | | | | | |
| N24 | NA | dss_data21 | 0 | O | L | L | 7 | vdds | Yes | 8 | PU100/ PD100 | LVC MOS |
| | | mcspi3_cs0 | 2 | IO | | | | | | | | |
| | | dss_data3 | 3 | IO | | | | | | | | |
| | | gpio_91 | 4 | IO | | | | | | | | |
| | | safe_mode | 7 | - | | | | | | | | |
| K24 | NA | dss_hsync | 0 | O | H | H | 7 | vdds | Yes | 4 | PU100/ PD100 | LVC MOS |
| | | gpio_67 | 4 | IO | | | | | | | | |
| | | hw_dbg13 | 5 | O | | | | | | | | |

Table 2-2. Ball Characteristics (CBC Pkg.) (continued)

| BALL BOTTOM [1] | BALL TOP [2] | PIN NAME [3] | MODE [4] | TYPE [5] | BALL RESET STATE [6] | BALL RESET REL. STATE [7] | RESET REL. MODE [8] | POWER [9] | HYS [10] | BUFFER STRENGTH (mA) [11] | PULLUP /DOWN TYPE [12] | IO CELL [13] |
|-----------------|--------------|------------------|----------|----------|----------------------|---------------------------|---------------------|-----------|----------|---------------------------|------------------------|--------------|
| | | safe_mode | 7 | - | | | | | | | | |
| M25 | NA | dss_vsync | 0 | O | H | H | 7 | vdds | Yes | 4 | PU100/ PD100 | LVCMOS |
| | | gpio_68 | 4 | IO | | | | | | | | |
| | | safe_mode | 7 | - | | | | | | | | |
| R8 | NA | mcspi1_cs1 | 0 | O | H | H | 7 | vdds | Yes | 4 ⁽⁶⁾ | PU100/ PD100 | LVCMOS |
| | | mmc3_cmd | 3 | IO | | | | | | | | |
| | | gpio_175 | 4 | IO | | | | | | | | |
| | | safe_mode | 7 | - | | | | | | | | |
| T8 | NA | mcspi1_cs3 | 0 | O | H | H | 7 | vdds | Yes | 4 ⁽³⁾ | PU100/ PD100 | LVCMOS |
| | | hsusb2_tll_data2 | 2 | IO | | | | | | | | |
| | | hsusb2_data2 | 3 | IO | | | | | | | | |
| | | gpio_177 | 4 | IO | | | | | | | | |
| | | mm2_txdat | 5 | IO | | | | | | | | |
| | | safe_mode | 7 | - | | | | | | | | |
| V9 | NA | mcspi2_cs1 | 0 | O | L | L | 7 | vdds | Yes | 4 ⁽³⁾ | PU100/ PD100 | LVCMOS |
| | | gpt8_pwm_evt | 1 | IO | | | | | | | | |
| | | hsusb2_tll_data3 | 2 | IO | | | | | | | | |
| | | hsusb2_data3 | 3 | IO | | | | | | | | |
| | | gpio_182 | 4 | IO | | | | | | | | |
| | | mm2_txen_n | 5 | IO | | | | | | | | |
| | | safe_mode | 7 | - | | | | | | | | |
| T19 | NA | mcbasp_clks | 0 | I | L | L | 7 | vdds | Yes | 4 ⁽³⁾ | PU100/ PD100 | LVCMOS |
| | | cam_shutter | 2 | O | | | | | | | | |
| | | gpio_160 | 4 | IO | | | | | | | | |
| | | uart1_cts | 5 | I | | | | | | | | |
| | | safe_mode | 7 | - | | | | | | | | |
| AB2 | NA | etk_clk | 0 | O | H | H | 4 | vdds | Yes | 4 ⁽³⁾ | PU100/ PD100 | LVCMOS |
| | | mcbasp5_clkx | 1 | IO | | | | | | | | |
| | | mmc3_clk | 2 | O | | | | | | | | |
| | | hsusb1_stp | 3 | O | | | | | | | | |
| | | gpio_12 | 4 | IO | | | | | | | | |
| | | mm1_rxdp | 5 | IO | | | | | | | | |
| | | hsusb1_tll_stp | 6 | I | | | | | | | | |
| | | hw_dbg0 | 7 | O | | | | | | | | |
| AB3 | NA | etk_ctl | 0 | O | H | H | 4 | vdds | Yes | 4 ⁽³⁾ | PU100/ PD100 | LVCMOS |
| | | mmc3_cmd | 2 | IO | | | | | | | | |
| | | hsusb1_clk | 3 | O | | | | | | | | |
| | | gpio_13 | 4 | IO | | | | | | | | |
| | | hsusb1_tll_clk | 6 | O | | | | | | | | |
| | | hw_dbg1 | 7 | O | | | | | | | | |
| AC3 | NA | etk_d0 | 0 | O | H | H | 4 | vdds | Yes | 4 ⁽³⁾ | PU100/ PD100 | LVCMOS |
| | | mcspi3_simo | 1 | IO | | | | | | | | |
| | | mmc3_dat4 | 2 | IO | | | | | | | | |
| | | hsusb1_data0 | 3 | IO | | | | | | | | |

Table 2-2. Ball Characteristics (CBC Pkg.) (continued)

| BALL BOTTOM [1] | BALL TOP [2] | PIN NAME [3] | MODE [4] | TYPE [5] | BALL RESET STATE [6] | BALL RESET REL. STATE [7] | RESET REL. MODE [8] | POWER [9] | HYS [10] | BUFFER STRENGTH (mA) [11] | PULLUP /DOWN TYPE [12] | IO CELL [13] |
|-----------------|--------------|-----------------|----------|----------|----------------------|---------------------------|---------------------|-----------|----------|---------------------------|------------------------|--------------|
| | | gpio_14 | 4 | IO | | | | | | | | |
| | | mm1_rxcv | 5 | IO | | | | | | | | |
| | | hsusb1_tll_ata0 | 6 | IO | | | | | | | | |
| | | hw_dbg2 | 7 | O | | | | | | | | |
| AD4 | NA | etk_d1 | 0 | O | H | H | 4 | vdds | Yes | 4 ⁽³⁾ | PU100/PD100 | LVC MOS |
| | | mcspi3_somi | 1 | IO | | | | | | | | |
| | | hsusb1_data1 | 3 | IO | | | | | | | | |
| | | gpio_15 | 4 | IO | | | | | | | | |
| | | mm1_txse0 | 5 | IO | | | | | | | | |
| | | hsusb1_tll_ata1 | 6 | IO | | | | | | | | |
| | | hw_dbg3 | 7 | O | | | | | | | | |
| AD3 | NA | etk_d2 | 0 | O | H | H | 4 | vdds | Yes | 4 ⁽³⁾ | PU100/PD100 | LVC MOS |
| | | mcspi3_cs0 | 1 | IO | | | | | | | | |
| | | hsusb1_data2 | 3 | IO | | | | | | | | |
| | | gpio_16 | 4 | IO | | | | | | | | |
| | | mm1_txd | 5 | IO | | | | | | | | |
| | | hsusb1_tll_ata2 | 6 | IO | | | | | | | | |
| | | hw_dbg4 | 7 | O | | | | | | | | |
| AA3 | NA | etk_d3 | 0 | O | H | H | 4 | vdds | Yes | 4 ⁽³⁾ | PU100/PD100 | LVC MOS |
| | | mcspi3_clk | 1 | IO | | | | | | | | |
| | | mmc3_dat3 | 2 | IO | | | | | | | | |
| | | hsusb1_data7 | 3 | IO | | | | | | | | |
| | | gpio_17 | 4 | IO | | | | | | | | |
| | | hsusb1_tll_ata7 | 6 | IO | | | | | | | | |
| | | hw_dbg5 | 7 | O | | | | | | | | |
| Y3 | NA | etk_d4 | 0 | O | L | L | 4 | vdds | Yes | 4 ⁽³⁾ | PU100/PD100 | LVC MOS |
| | | mcbsp5_dr | 1 | I | | | | | | | | |
| | | mmc3_dat0 | 2 | IO | | | | | | | | |
| | | hsusb1_data4 | 3 | IO | | | | | | | | |
| | | gpio_18 | 4 | IO | | | | | | | | |
| | | hsusb1_tll_ata4 | 6 | IO | | | | | | | | |
| | | hw_dbg6 | 7 | O | | | | | | | | |
| AB1 | NA | etk_d5 | 0 | O | L | L | 4 | vdds | Yes | 4 ⁽³⁾ | PU100/PD100 | LVC MOS |
| | | mcbsp5_fsx | 1 | IO | | | | | | | | |
| | | mmc3_dat1 | 2 | IO | | | | | | | | |
| | | hsusb1_data5 | 3 | IO | | | | | | | | |
| | | gpio_19 | 4 | IO | | | | | | | | |
| | | hsusb1_tll_ata5 | 6 | IO | | | | | | | | |
| | | hw_dbg7 | 7 | O | | | | | | | | |
| AE3 | NA | etk_d6 | 0 | O | L | L | 4 | vdds | Yes | 4 ⁽³⁾ | PU100/PD100 | LVC MOS |
| | | mcbsp5_dx | 1 | IO | | | | | | | | |
| | | mmc3_dat2 | 2 | IO | | | | | | | | |
| | | hsusb1_data6 | 3 | IO | | | | | | | | |

Table 2-2. Ball Characteristics (CBC Pkg.) (continued)

| BALL BOTTOM [1] | BALL TOP [2] | PIN NAME [3] | MODE [4] | TYPE [5] | BALL RESET STATE [6] | BALL RESET REL. STATE [7] | RESET REL. MODE [8] | POWER [9] | HYS [10] | BUFFER STRENGTH (mA) [11] | PULLUP /DOWN TYPE [12] | IO CELL [13] |
|-----------------|--------------|----------------------|----------|----------|----------------------|---------------------------|---------------------|-----------|----------|---------------------------|------------------------|--------------|
| | | gpio_20 | 4 | IO | | | | | | | | |
| | | hsusb1_tll_ata6 | 6 | IO | | | | | | | | |
| | | hw_dbg8 | 7 | O | | | | | | | | |
| AD2 | NA | etk_d7 | 0 | O | L | L | 4 | vdds | Yes | 4 ⁽³⁾ | PU100/ PD100 | LVC MOS |
| | | mcspi3_cs1 | 1 | O | | | | | | | | |
| | | mmc3_dat7 | 2 | IO | | | | | | | | |
| | | hsusb1_data3 | 3 | IO | | | | | | | | |
| | | gpio_21 | 4 | IO | | | | | | | | |
| | | mm1_txen_n | 5 | IO | | | | | | | | |
| | | hsusb1_tll_ata3 | 6 | IO | | | | | | | | |
| | | hw_dbg9 | 7 | O | | | | | | | | |
| AA4 | NA | etk_d8 | 0 | O | L | L | 4 | vdds | Yes | 4 ⁽³⁾ | PU100/ PD100 | LVC MOS |
| | | sys_drm_secure | 1 | O | | | | | | | | |
| | | mmc3_dat6 | 2 | IO | | | | | | | | |
| | | hsusb1_dir | 3 | I | | | | | | | | |
| | | gpio_22 | 4 | IO | | | | | | | | |
| | | hsusb1_tll_dir | 6 | O | | | | | | | | |
| | | hw_dbg10 | 7 | O | | | | | | | | |
| V2 | NA | etk_d9 | 0 | O | L | L | 4 | vdds | Yes | 4 ⁽³⁾ | PU100/ PD100 | LVC MOS |
| | | sys_secure_indicator | 1 | O | | | | | | | | |
| | | mmc3_dat5 | 2 | IO | | | | | | | | |
| | | hsusb1_nxt | 3 | I | | | | | | | | |
| | | gpio_23 | 4 | IO | | | | | | | | |
| | | mm1_rxdm | 5 | IO | | | | | | | | |
| | | hsusb1_tll_nxt | 6 | O | | | | | | | | |
| | | hw_dbg11 | 7 | O | | | | | | | | |
| AE4 | NA | etk_d10 | 0 | O | L | L | 4 | vdds | Yes | 4 ⁽³⁾ | PU100/ PD100 | LVC MOS |
| | | uart1_rx | 2 | I | | | | | | | | |
| | | hsusb2_clk | 3 | O | | | | | | | | |
| | | gpio_24 | 4 | IO | | | | | | | | |
| | | hsusb2_tll_clk | 6 | O | | | | | | | | |
| | | hw_dbg12 | 7 | O | | | | | | | | |
| AF6 | NA | etk_d11 | 0 | O | L | L | 4 | vdds | Yes | 4 ⁽³⁾ | PU100/ PD100 | LVC MOS |
| | | hsusb2_stp | 3 | O | | | | | | | | |
| | | gpio_25 | 4 | IO | | | | | | | | |
| | | mm2_rxdp | 5 | IO | | | | | | | | |
| | | hsusb2_tll_stp | 6 | I | | | | | | | | |
| | | hw_dbg13 | 7 | O | | | | | | | | |
| AE6 | NA | etk_d12 | 0 | O | L | L | 4 | vdds | Yes | 4 ⁽³⁾ | PU100/ PD100 | LVC MOS |
| | | hsusb2_dir | 3 | I | | | | | | | | |
| | | gpio_26 | 4 | IO | | | | | | | | |
| | | hsusb2_tll_dir | 6 | O | | | | | | | | |
| | | hw_dbg14 | 7 | O | | | | | | | | |
| AF7 | NA | etk_d13 | 0 | O | L | L | 4 | vdds | Yes | 4 ⁽³⁾ | PU100/ PD100 | LVC MOS |

Table 2-2. Ball Characteristics (CBC Pkg.) (continued)

| BALL BOTTOM [1] | BALL TOP [2] | PIN NAME [3] | MODE [4] | TYPE [5] | BALL RESET STATE [6] | BALL RESET REL. STATE [7] | RESET REL. MODE [8] | POWER [9] | HYS [10] | BUFFER STRENGTH (mA) [11] | PULLUP /DOWN TYPE [12] | IO CELL [13] |
|-----------------|--------------|------------------|----------|----------|----------------------|---------------------------|---------------------|-----------|----------|---------------------------|------------------------|--------------|
| | | hsusb2_nxt | 3 | I | | | | | | | | |
| | | gpio_27 | 4 | IO | | | | | | | | |
| | | mm2_rxdm | 5 | IO | | | | | | | | |
| | | hsusb2_tll_nxt | 6 | O | | | | | | | | |
| | | hw_dbg15 | 7 | O | | | | | | | | |
| AF9 | NA | etk_d14 | 0 | O | L | L | 4 | vdds | Yes | 4 ⁽³⁾ | PU100/ PD100 | LVC MOS |
| | | hsusb2_data0 | 3 | IO | | | | | | | | |
| | | gpio_28 | 4 | IO | | | | | | | | |
| | | mm2_rxcv | 5 | IO | | | | | | | | |
| | | hsusb2_tll_data0 | 6 | IO | | | | | | | | |
| | | hw_dbg16 | 7 | O | | | | | | | | |
| AE9 | NA | etk_d15 | 0 | O | L | L | 4 | vdds | Yes | 4 ⁽³⁾ | PU100/ PD100 | LVC MOS |
| | | hsusb2_data1 | 3 | IO | | | | | | | | |
| | | gpio_29 | 4 | IO | | | | | | | | |
| | | mm2_txse0 | 5 | IO | | | | | | | | |
| | | hsusb2_tll_data1 | 6 | IO | | | | | | | | |
| | | hw_dbg17 | 7 | O | | | | | | | | |
| Y15 | NA | jtag_emu0 | 0 | IO | H | H | 0 | vdds | Yes | 4 | PU100/ PD100 | LVC MOS |
| | | gpio_11 | 4 | IO | | | | | | | | |
| | | safe_mode | 7 | - | | | | | | | | |
| Y14 | NA | jtag_emu1 | 0 | IO | H | H | 0 | vdds | Yes | 4 | PU100/ PD100 | LVC MOS |
| | | gpio_31 | 4 | IO | | | | | | | | |
| | | safe_mode | 7 | - | | | | | | | | |
| U3 | NA | mcbasp3_clkx | 0 | IO | L | L | 7 | vdds | Yes | 4 ⁽³⁾ | PU100/ PD100 | LVC MOS |
| | | uart2_tx | 1 | O | | | | | | | | |
| | | gpio_142 | 4 | IO | | | | | | | | |
| | | hsusb3_tll_data6 | 5 | IO | | | | | | | | |
| | | safe_mode | 7 | - | | | | | | | | |
| N3 | NA | mcbasp3_dr | 0 | I | L | L | 7 | vdds | Yes | 4 ⁽³⁾ | PU100/ PD100 | LVC MOS |
| | | uart2_rts | 1 | O | | | | | | | | |
| | | gpio_141 | 4 | IO | | | | | | | | |
| | | hsusb3_tll_data5 | 5 | IO | | | | | | | | |
| | | safe_mode | 7 | - | | | | | | | | |
| P3 | NA | mcbasp3_dx | 0 | IO | L | L | 7 | vdds | Yes | 4 ⁽³⁾ | PU100/ PD100 | LVC MOS |
| | | uart2_cts | 1 | I | | | | | | | | |
| | | gpio_140 | 4 | IO | | | | | | | | |
| | | hsusb3_tll_data4 | 5 | IO | | | | | | | | |
| | | safe_mode | 7 | - | | | | | | | | |
| W3 | NA | mcbasp3_fsx | 0 | IO | L | L | 7 | vdds | Yes | 4 ⁽³⁾ | PU100/ PD100 | LVC MOS |
| | | uart2_rx | 1 | I | | | | | | | | |
| | | gpio_143 | 4 | IO | | | | | | | | |
| | | hsusb3_tll_data7 | 5 | IO | | | | | | | | |
| | | safe_mode | 7 | - | | | | | | | | |

Table 2-2. Ball Characteristics (CBC Pkg.) (continued)

| BALL BOTTOM [1] | BALL TOP [2] | PIN NAME [3] | MODE [4] | TYPE [5] | BALL RESET STATE [6] | BALL RESET REL. STATE [7] | RESET REL. MODE [8] | POWER [9] | HYS [10] | BUFFER STRENGTH (mA) [11] | PULLUP /DOWN TYPE [12] | IO CELL [13] |
|-----------------|--------------|----------------------|----------|----------|----------------------|---------------------------|---------------------|-----------|----------|---------------------------|------------------------|--------------|
| V3 | NA | mcbasp4_clkx | 0 | IO | L | L | 7 | vdds | Yes | 4 ⁽³⁾ | PU100/ PD100 | LVCMOS |
| | | gpio_152 | 4 | IO | | | | | | | | |
| | | hsusb3_tll_d ata1 | 5 | IO | | | | | | | | |
| | | mm3_txse0 | 6 | IO | | | | | | | | |
| | | safe_mode | 7 | - | | | | | | | | |
| U4 | NA | mcbasp4_dr | 0 | I | L | L | 7 | vdds | Yes | 4 ⁽³⁾ | PU100/ PD100 | LVCMOS |
| | | gpio_153 | 4 | IO | | | | | | | | |
| | | hsusb3_tll_d ata0 | 5 | IO | | | | | | | | |
| | | mm3_rxrcv | 6 | IO | | | | | | | | |
| | | safe_mode | 7 | - | | | | | | | | |
| R3 | NA | mcbasp4_dx | 0 | IO | L | L | 7 | vdds | Yes | 4 ⁽³⁾ | PU100/ PD100 | LVCMOS |
| | | gpio_154 | 4 | IO | | | | | | | | |
| | | hsusb3_tll_d ata2 | 5 | IO | | | | | | | | |
| | | mm3_txdat | 6 | IO | | | | | | | | |
| | | safe_mode | 7 | - | | | | | | | | |
| T3 | NA | mcbasp4_fsx | 0 | IO | L | L | 7 | vdds | Yes | 4 ⁽³⁾ | PU100/ PD100 | LVCMOS |
| | | gpio_155 | 4 | IO | | | | | | | | |
| | | hsusb3_tll_d ata3 | 5 | IO | | | | | | | | |
| | | mm3_txen_n | 6 | IO | | | | | | | | |
| | | safe_mode | 7 | - | | | | | | | | |
| M3 | NA | mmc2_dat5 | 0 | IO | L | L | 7 | vdds | Yes | 4 ⁽³⁾ | PU100/ PD100 | LVCMOS |
| | | mmc2_dir_da t1 | 1 | O | | | | | | | | |
| | | cam_global_r eset | 2 | IO | | | | | | | | |
| | | mmc3_dat1 | 3 | IO | | | | | | | | |
| | | gpio_137 | 4 | IO | | | | | | | | |
| | | hsusb3_tll_st p | 5 | I | | | | | | | | |
| | | mm3_rxdp | 6 | IO | | | | | | | | |
| | | safe_mode | 7 | - | | | | | | | | |
| L3 | NA | mmc2_dat6 | 0 | IO | L | L | 7 | vdds | Yes | 4 ⁽³⁾ | PU100/ PD100 | LVCMOS |
| | | mmc2_dir_c md | 1 | O | | | | | | | | |
| | | cam_shutter | 2 | O | | | | | | | | |
| | | mmc3_dat2 | 3 | IO | | | | | | | | |
| | | gpio_138 | 4 | IO | | | | | | | | |
| | | hsusb3_tll_di r | 5 | O | | | | | | | | |
| | | safe_mode | 7 | - | | | | | | | | |
| K3 | NA | mmc2_dat7 | 0 | IO | L | L | 7 | vdds | Yes | 4 ⁽³⁾ | PU100/ PD100 | LVCMOS |
| | | mmc2_clkin | 1 | I | | | | | | | | |
| | | mmc3_dat3 | 3 | IO | | | | | | | | |
| | | gpio_139 | 4 | IO | | | | | | | | |
| | | hsusb3_tll_n xt | 5 | IO | | | | | | | | |
| | | mm3_rxdm | 6 | IO | | | | | | | | |
| safe_mode | 7 | - | | | | | | | | | | |
| W2 | NA | uart1_cts | 0 | I | L | L | 7 | vdds | Yes | 4 ⁽³⁾ | PU100/ PD100 | LVCMOS |

Table 2-2. Ball Characteristics (CBC Pkg.) (continued)

| BALL BOTTOM [1] | BALL TOP [2] | PIN NAME [3] | MODE [4] | TYPE [5] | BALL RESET STATE [6] | BALL RESET REL. STATE [7] | RESET REL. MODE [8] | POWER [9] | HYS [10] | BUFFER STRENGTH (mA) [11] | PULLUP /DOWN TYPE [12] | IO CELL [13] |
|---|--------------|--|----------|----------|----------------------|---------------------------|---------------------|-----------|----------|---------------------------|------------------------|--------------|
| | | gpio_150 | 4 | IO | | | | | | | | |
| | | hsusb3_tll_clk | 5 | O | | | | | | | | |
| | | safe_mode | 7 | - | | | | | | | | |
| AC21, D15, G11, G18, H20, M7, M17, R20, T7, Y8, Y12 | NA | vdd_core | 0 | PWR | - | - | - | - | - | - | - | - |
| D13, G9, G12, H7, K11, L9, M9, M10, N7, N8, P10, U7, U11, U13, V7, V11, W9, Y9, Y11 | NA | vdd_mpu_iva | 0 | PWR | - | - | - | - | - | - | - | - |
| A18, AC7, AC15, AC18, AC24, AD20, AE10, C11, D9, E24, G4, J15, J18, L7, L24, M4, T4, T24, W24, Y4, L20, AB24, AD18, AD19 | NA | vdds | 0 | PWR | - | - | - | - | - | - | - | - |
| U12 | NA | vdds_sram | 0 | PWR | - | - | - | - | - | - | - | - |
| K13 | NA | vdds_dpil_dll | 0 | PWR | - | - | - | - | - | - | - | - |
| U14 | NA | vdds_dpil_per | 0 | PWR | - | - | - | - | - | - | - | - |
| W14 | NA | vdds_wkup_bg | 0 | PWR | - | - | - | - | - | - | - | - |
| N23, P23 | NA | vdds_mmc1, vdds_mmc1a | 0 | PWR | - | - | - | - | - | - | - | - |
| V25 | NA | vdda_dac | 0 | PWR | - | - | - | - | - | - | - | - |
| V24 | NA | vssa_dac | 0 | PWR | - | - | - | - | - | - | - | - |
| A6, A8, A13, AB5, AB22, AC10, AC16, AC19, AD14, AD25, AE7, AF23, B2, B25, C12, D7, D10, D12, D14, D18, D20, E22, G1, G8, G10, G20, G23, H4, K1, K15, K25, L10, L17, L19, L23, N4, N10, N17, R1, R4, R17, T23, U25, W1, W4, W23, Y7, Y10, Y16, Y26 | NA | vss | 0 | GND | - | - | - | - | - | - | - | - |
| K14, K20, N9, AE19 | NA | cap_vdd_wkup, cap_vdd_sram_core, cap_vdd_sram_mpu_iva, cap_vdd_d | 0 | PWR | - | - | - | - | - | - | - | - |

Table 2-2. Ball Characteristics (CBC Pkg.) (continued)

| BALL BOTTOM [1] | BALL TOP [2] | PIN NAME [3] | MODE [4] | TYPE [5] | BALL RESET STATE [6] | BALL RESET REL. STATE [7] | RESET REL. MODE [8] | POWER [9] | HYS [10] | BUFFER STRENGTH (mA) [11] | PULLUP /DOWN TYPE [12] | IO CELL [13] |
|---|---|---------------------------------|----------|----------|----------------------|---------------------------|---------------------|-----------|----------|---------------------------|------------------------|--------------|
| A1, L1, AF1, T2, Y2, AE2, AF4, AF5, AF8, AF10, AF12, AF13, AF14, AF15, AF17, AF16, A20, AF21, AF18, AF24, AF22, A25, AE25, AF25, A26, B26, K26, U26, AE26, AF26 | A1, J1, AA1, N2, T2, W2, Y2, AA6, Y7, Y9, AA10, AA11, AA12, AA13, Y14, AA14, B16, Y17, AA17, Y19, AA19, A20, Y20, AA20, A21, B21, H21, P21, Y21, AA21 | FeedThrough Pins ⁽⁶⁾ | - | - | - | - | - | - | - | - | - | - |
| A2, A4, A5, A7, A9, A10, A11, A12, A14, A15, A16, A17, A19, A21, A22, AA23, AB23, AC9, AC12, AC13, AC14, AC17, AC20, AC22, AC23, AD9, AD11, AD12, AD13, AE1, AE8, AE11, AE12, AE13, AF2, AF3, AF11, B1, B7, B8, B9, B10, B11, B12, B13, B14, B15, B16, B17, B18, B19, B20, B21, B22, C7, C8, C9, C10, C13, C14, C15, C16, C17, C18, C19, C20, C21, C22, D5, D6, D8, D11, D16, D17, D19, D21, D22, E23, F4, G7, G13, G14, G15, G16, G17, G19, H8, H9, H10, H11, H12, H13, H14, H15, H16, H17, H18, H19, H23, J3, J4, J7, J8, J9, J10, J11, J12, J13, J14, J16, J17, J19, J20, K4, K7, K8, K9, K10, K12, K16, K17, K19, K23, L8, M8, M23, N18, P2, P4, P24, R23, R24, R25, R26, T25, T26, U23, V4, W12, Y23 | - | No Connect | - | - | - | - | - | - | - | - | - | - |

(6) These signals are feed-through balls. For more information, refer to [Section 2.5.10](#).

Table 2-3. Ball Characteristics (CUS Pkg.)

| BALL BOTTOM [1] | BALL TOP [2] | PIN NAME [3] | MODE [4] | TYPE [5] | BALL RESET STATE [6] | BALL RESET REL. STATE [7] | RESET REL. MODE [8] | POWER [9] | HYS [10] | BUFFER STRENGTH (mA) [11] | PULLUP /DOWN TYPE [12] |
|-----------------|--------------|--------------|----------|----------|----------------------|---------------------------|---------------------|-----------|----------|---------------------------|------------------------|
| D7 | sdr_c_d0 | 0 | IO | L | Z | 0 | vdds_mem | Yes | 4 | PU/ PD | LVC MOS |
| C5 | sdr_c_d1 | 0 | IO | L | Z | 0 | vdds_mem | Yes | 4 | PU/ PD | LVC MOS |
| C6 | sdr_c_d2 | 0 | IO | L | Z | 0 | vdds_mem | Yes | 4 | PU/ PD | LVC MOS |
| B5 | sdr_c_d3 | 0 | IO | L | Z | 0 | vdds_mem | Yes | 4 | PU/ PD | LVC MOS |
| D9 | sdr_c_d4 | 0 | IO | L | Z | 0 | vdds_mem | Yes | 4 | PU/ PD | LVC MOS |
| D10 | sdr_c_d5 | 0 | IO | L | Z | 0 | vdds_mem | Yes | 4 | PU/ PD | LVC MOS |
| C7 | sdr_c_d6 | 0 | IO | L | Z | 0 | vdds_mem | Yes | 4 | PU/ PD | LVC MOS |
| B7 | sdr_c_d7 | 0 | IO | L | Z | 0 | vdds_mem | Yes | 4 | PU/ PD | LVC MOS |
| B11 | sdr_c_d8 | 0 | IO | L | Z | 0 | vdds_mem | Yes | 4 | PU/ PD | LVC MOS |
| C12 | sdr_c_d9 | 0 | IO | L | Z | 0 | vdds_mem | Yes | 4 | PU/ PD | LVC MOS |
| B12 | sdr_c_d10 | 0 | IO | L | Z | 0 | vdds_mem | Yes | 4 | PU/ PD | LVC MOS |
| D13 | sdr_c_d11 | 0 | IO | L | Z | 0 | vdds_mem | Yes | 4 | PU/ PD | LVC MOS |
| C13 | sdr_c_d12 | 0 | IO | L | Z | 0 | vdds_mem | Yes | 4 | PU/ PD | LVC MOS |
| B14 | sdr_c_d13 | 0 | IO | L | Z | 0 | vdds_mem | Yes | 4 | PU/ PD | LVC MOS |
| A14 | sdr_c_d14 | 0 | IO | L | Z | 0 | vdds_mem | Yes | 4 | PU/ PD | LVC MOS |
| B15 | sdr_c_d15 | 0 | IO | L | Z | 0 | vdds_mem | Yes | 4 | PU/ PD | LVC MOS |
| C9 | sdr_c_d16 | 0 | IO | L | Z | 0 | vdds_mem | Yes | 4 | PU/ PD | LVC MOS |
| E12 | sdr_c_d17 | 0 | IO | L | Z | 0 | vdds_mem | Yes | 4 | PU/ PD | LVC MOS |
| B8 | sdr_c_d18 | 0 | IO | L | Z | 0 | vdds_mem | Yes | 4 | PU/ PD | LVC MOS |
| B9 | sdr_c_d19 | 0 | IO | L | Z | 0 | vdds_mem | Yes | 4 | PU/ PD | LVC MOS |
| C10 | sdr_c_d20 | 0 | IO | L | Z | 0 | vdds_mem | Yes | 4 | PU/ PD | LVC MOS |
| B10 | sdr_c_d21 | 0 | IO | L | Z | 0 | vdds_mem | Yes | 4 | PU/ PD | LVC MOS |
| D12 | sdr_c_d22 | 0 | IO | L | Z | 0 | vdds_mem | Yes | 4 | PU/ PD | LVC MOS |
| E13 | sdr_c_d23 | 0 | IO | L | Z | 0 | vdds_mem | Yes | 4 | PU/ PD | LVC MOS |
| E15 | sdr_c_d24 | 0 | IO | L | Z | 0 | vdds_mem | Yes | 4 | PU/ PD | LVC MOS |
| D15 | sdr_c_d25 | 0 | IO | L | Z | 0 | vdds_mem | Yes | 4 | PU/ PD | LVC MOS |
| C15 | sdr_c_d26 | 0 | IO | L | Z | 0 | vdds_mem | Yes | 4 | PU/ PD | LVC MOS |
| B16 | sdr_c_d27 | 0 | IO | L | Z | 0 | vdds_mem | Yes | 4 | PU/ PD | LVC MOS |
| C16 | sdr_c_d28 | 0 | IO | L | Z | 0 | vdds_mem | Yes | 4 | PU/ PD | LVC MOS |
| D16 | sdr_c_d29 | 0 | IO | L | Z | 0 | vdds_mem | Yes | 4 | PU/ PD | LVC MOS |
| B17 | sdr_c_d30 | 0 | IO | L | Z | 0 | vdds_mem | Yes | 4 | PU/ PD | LVC MOS |
| B18 | sdr_c_d31 | 0 | IO | L | Z | 0 | vdds_mem | Yes | 4 | PU/ PD | LVC MOS |
| C18 | sdr_c_ba0 | 0 | O | 0 | 0 | 0 | vdds_mem | No | 4 | NA | LVC MOS |
| D18 | sdr_c_ba1 | 0 | O | 0 | 0 | 0 | vdds_mem | No | 4 | NA | LVC MOS |
| A4 | sdr_c_a0 | 0 | O | 0 | 0 | 0 | vdds_mem | No | 4 | NA | LVC MOS |
| B4 | sdr_c_a1 | 0 | O | 0 | 0 | 0 | vdds_mem | No | 4 | NA | LVC MOS |
| D6 | sdr_c_a2 | 0 | O | 0 | 0 | 0 | vdds_mem | No | 4 | NA | LVC MOS |
| B3 | sdr_c_a3 | 0 | O | 0 | 0 | 0 | vdds_mem | No | 4 | NA | LVC MOS |
| B2 | sdr_c_a4 | 0 | O | 0 | 0 | 0 | vdds_mem | No | 4 | NA | LVC MOS |
| C3 | sdr_c_a5 | 0 | O | 0 | 0 | 0 | vdds_mem | No | 4 | NA | LVC MOS |
| E3 | sdr_c_a6 | 0 | O | 0 | 0 | 0 | vdds_mem | No | 4 | NA | LVC MOS |
| F6 | sdr_c_a7 | 0 | O | 0 | 0 | 0 | vdds_mem | No | 4 | NA | LVC MOS |
| E10 | sdr_c_a8 | 0 | O | 0 | 0 | 0 | vdds_mem | No | 4 | NA | LVC MOS |
| E9 | sdr_c_a9 | 0 | O | 0 | 0 | 0 | vdds_mem | No | 4 | NA | LVC MOS |
| E7 | sdr_c_a10 | 0 | O | 0 | 0 | 0 | vdds_mem | No | 4 | NA | LVC MOS |
| G6 | sdr_c_a11 | 0 | O | 0 | 0 | 0 | vdds_mem | No | 4 | NA | LVC MOS |
| G7 | sdr_c_a12 | 0 | O | 0 | 0 | 0 | vdds_mem | No | 4 | NA | LVC MOS |
| F7 | sdr_c_a13 | 0 | O | 0 | 0 | 0 | vdds_mem | No | 4 | NA | LVC MOS |
| F9 | sdr_c_a14 | 0 | O | 0 | 0 | 0 | vdds_mem | No | 4 | NA | LVC MOS |
| A19 | sdr_c_ncs0 | 0 | O | 1 | 1 | 0 | vdds_mem | No | 4 | NA | LVC MOS |
| B19 | sdr_c_ncs1 | 0 | O | 1 | 1 | 0 | vdds_mem | No | 4 | NA | LVC MOS |
| A10 | sdr_c_clk | 0 | IO | L | 0 | 0 | vdds_mem | Yes | 4 | PU/ PD | LVC MOS |
| A11 | sdr_c_nclk | 0 | O | 1 | 1 | 0 | vdds_mem | No | 4 | NA | LVC MOS |

Table 2-3. Ball Characteristics (CUS Pkg.) (continued)

| BALL BOTTOM [1] | BALL TOP [2] | PIN NAME [3] | MODE [4] | TYPE [5] | BALL RESET STATE [6] | BALL RESET REL. STATE [7] | RESET REL. MODE [8] | POWER [9] | HYS [10] | BUFFER STRENGTH (mA) [11] | PULLUP /DOWN TYPE [12] |
|-----------------|--------------|--------------|----------|----------|----------------------|---------------------------|---------------------|-----------|----------|---------------------------|------------------------|
| B20 | sdrcke0 | 0 | O | H | 1 | 7 | vdds_mem | Yes | 4 | PU/ PD | LVC MOS |
| | safe_mode | 7 | | | | | | | | | |
| C20 | sdrcke1 | 0 | O | H | 1 | 7 | vdds_mem | Yes | 4 | PU/ PD | LVC MOS |
| | safe_mode | 7 | | | | | | | | | |
| D19 | sdrnras | 0 | O | 1 | 1 | 0 | vdds_mem | No | 4 | NA | LVC MOS |
| C19 | sdrncas | 0 | O | 1 | 1 | 0 | vdds_mem | No | 4 | NA | LVC MOS |
| A20 | sdrnwe | 0 | O | 1 | 1 | 0 | vdds_mem | No | 4 | NA | LVC MOS |
| B6 | sdrdm0 | 0 | O | 0 | 0 | 0 | vdds_mem | No | 4 | NA | LVC MOS |
| B13 | sdrdm1 | 0 | O | 0 | 0 | 0 | vdds_mem | No | 4 | NA | LVC MOS |
| A7 | sdrdm2 | 0 | O | 0 | 0 | 0 | vdds_mem | No | 4 | NA | LVC MOS |
| A16 | sdrdm3 | 0 | O | 0 | 0 | 0 | vdds_mem | No | 4 | NA | LVC MOS |
| A5 | sdrdqs0 | 0 | IO | L | Z | 0 | vdds_mem | Yes | 4 | PU/ PD | LVC MOS |
| A13 | sdrdqs1 | 0 | IO | L | Z | 0 | vdds_mem | Yes | 4 | PU/ PD | LVC MOS |
| A8 | sdrdqs2 | 0 | IO | L | Z | 0 | vdds_mem | Yes | 4 | PU/ PD | LVC MOS |
| A17 | sdrdqs3 | 0 | IO | L | Z | 0 | vdds_mem | Yes | 4 | PU/ PD | LVC MOS |
| K4 | gpmc_a1 | 0 | O | L | L | 7 | vdds_mem | Yes | 4 | PU/ PD | LVC MOS |
| | gpio_34 | 4 | IO | | | | | | | | |
| | safe_mode | 7 | | | | | | | | | |
| K3 | gpmc_a2 | 0 | O | L | L | 7 | vdds_mem | Yes | 4 | PU/ PD | LVC MOS |
| | gpio_35 | 4 | IO | | | | | | | | |
| | safe_mode | 7 | | | | | | | | | |
| K2 | gpmc_a3 | 0 | O | L | L | 7 | vdds_mem | Yes | 4 | PU/ PD | LVC MOS |
| | gpio_36 | 4 | IO | | | | | | | | |
| | safe_mode | 7 | | | | | | | | | |
| J4 | gpmc_a4 | 0 | O | L | L | 7 | vdds_mem | Yes | 4 | PU/ PD | LVC MOS |
| | gpio_37 | 4 | IO | | | | | | | | |
| | safe_mode | 7 | | | | | | | | | |
| J3 | gpmc_a5 | 0 | O | L | L | 7 | vdds_mem | Yes | 4 | PU/ PD | LVC MOS |
| | gpio_38 | 4 | IO | | | | | | | | |
| | safe_mode | 7 | | | | | | | | | |
| J2 | gpmc_a6 | 0 | O | H | H | 7 | vdds_mem | Yes | 4 | PU/ PD | LVC MOS |
| | gpio_39 | 4 | IO | | | | | | | | |
| | safe_mode | 7 | | | | | | | | | |
| J1 | gpmc_a7 | 0 | O | H | H | 7 | vdds_mem | Yes | 4 | PU/ PD | LVC MOS |
| | gpio_40 | 4 | IO | | | | | | | | |
| | safe_mode | 7 | | | | | | | | | |
| H1 | gpmc_a8 | 0 | O | H | H | 7 | vdds_mem | Yes | 4 | PU/ PD | LVC MOS |
| | gpio_41 | 4 | IO | | | | | | | | |
| | safe_mode | 7 | | | | | | | | | |
| H2 | gpmc_a9 | 0 | O | H | H | 7 | vdds_mem | Yes | 4 | PU/ PD | LVC MOS |
| | sys_ndmareq2 | 1 | I | | | | | | | | |
| | gpio_42 | 4 | IO | | | | | | | | |
| | safe_mode | 7 | | | | | | | | | |
| G2 | gpmc_a10 | 0 | O | H | H | 7 | vdds_mem | Yes | 4 | PU/ PD | LVC MOS |
| | sys_ndmareq3 | 1 | I | | | | | | | | |
| | gpio_43 | 4 | IO | | | | | | | | |
| | safe_mode | 7 | | | | | | | | | |
| L2 | gpmc_d0 | 0 | IO | H | H | 0 | vdds_mem | Yes | 4 | PU/ PD | LVC MOS |
| M1 | gpmc_d1 | 0 | IO | H | H | 0 | vdds_mem | Yes | 4 | PU/ PD | LVC MOS |
| M2 | gpmc_d2 | 0 | IO | H | H | 0 | vdds_mem | Yes | 4 | PU/ PD | LVC MOS |
| N2 | gpmc_d3 | 0 | IO | H | H | 0 | vdds_mem | Yes | 4 | PU/ PD | LVC MOS |
| M3 | gpmc_d4 | 0 | IO | H | H | 0 | vdds_mem | Yes | 4 | PU/ PD | LVC MOS |
| P1 | gpmc_d5 | 0 | IO | H | H | 0 | vdds_mem | Yes | 4 | PU/ PD | LVC MOS |

Table 2-3. Ball Characteristics (CUS Pkg.) (continued)

| BALL BOTTOM [1] | BALL TOP [2] | PIN NAME [3] | MODE [4] | TYPE [5] | BALL RESET STATE [6] | BALL RESET REL. STATE [7] | RESET REL. MODE [8] | POWER [9] | HYS [10] | BUFFER STRENGTH (mA) [11] | PULLUP /DOWN TYPE [12] |
|-----------------|---------------|--------------|----------|----------|----------------------|---------------------------|---------------------|-----------|----------|---------------------------|------------------------|
| P2 | gpmc_d6 | 0 | IO | H | H | 0 | vdds_mem | Yes | 4 | PU/ PD | LVC MOS |
| R1 | gpmc_d7 | 0 | IO | H | H | 0 | vdds_mem | Yes | 4 | PU/ PD | LVC MOS |
| R2 | gpmc_d8 | 0 | IO | H | H | 0 | vdds_mem | Yes | 4 | PU/ PD | LVC MOS |
| | gpio_44 | 4 | IO | | | | | | | | |
| | safe_mode | 7 | | | | | | | | | |
| T2 | gpmc_d9 | 0 | IO | H | H | 0 | vdds_mem | Yes | 4 | PU/ PD | LVC MOS |
| | gpio_45 | 4 | IO | | | | | | | | |
| | safe_mode | 7 | | | | | | | | | |
| U1 | gpmc_d10 | 0 | IO | H | H | 0 | vdds_mem | Yes | 4 | PU/ PD | LVC MOS |
| | gpio_46 | 4 | IO | | | | | | | | |
| | safe_mode | 7 | | | | | | | | | |
| R3 | gpmc_d11 | 0 | IO | H | H | 0 | vdds_mem | Yes | 4 | PU/ PD | LVC MOS |
| | gpio_47 | 4 | IO | | | | | | | | |
| | safe_mode | 7 | | | | | | | | | |
| T3 | gpmc_d12 | 0 | IO | H | H | 0 | vdds_mem | Yes | 4 | PU/ PD | LVC MOS |
| | gpio_48 | 4 | IO | | | | | | | | |
| | safe_mode | 7 | | | | | | | | | |
| U2 | gpmc_d13 | 0 | IO | H | H | 0 | vdds_mem | Yes | 4 | PU/ PD | LVC MOS |
| | gpio_49 | 4 | IO | | | | | | | | |
| | safe_mode | 7 | | | | | | | | | |
| V1 | gpmc_d14 | 0 | IO | H | H | 0 | vdds_mem | Yes | 4 | PU/ PD | LVC MOS |
| | gpio_50 | 4 | IO | | | | | | | | |
| | safe_mode | 7 | | | | | | | | | |
| V2 | gpmc_d15 | 0 | IO | H | H | 0 | vdds_mem | Yes | 4 | PU/ PD | LVC MOS |
| | gpio_51 | 4 | IO | | | | | | | | |
| | safe_mode | 7 | | | | | | | | | |
| E2 | gpmc_ncs0 | 0 | O | 1 | 1 | 0 | vdds_mem | No | 4 | NA | LVC MOS |
| D2 | gpmc_ncs3 | 0 | O | H | H | 7 | vdds_mem | Yes | 4 | PU/ PD | LVC MOS |
| | sys_ndmareq0 | 1 | I | | | | | | | | |
| | gpio_54 | 4 | IO | | | | | | | | |
| | safe_mode | 7 | | | | | | | | | |
| F4 | gpmc_ncs4 | 0 | O | H | H | 7 | vdds_mem | Yes | 4 | PU/ PD | LVC MOS |
| | sys_ndmareq1 | 1 | I | | | | | | | | |
| | mcb sp4_clkx | 2 | IO | | | | | | | | |
| | gpt9_pwm_evt | 3 | IO | | | | | | | | |
| | gpio_55 | 4 | IO | | | | | | | | |
| | safe_mode | 7 | | | | | | | | | |
| G5 | gpmc_ncs5 | 0 | O | H | H | 7 | vdds_mem | Yes | 4 | PU/ PD | LVC MOS |
| | sys_ndmareq2 | 1 | I | | | | | | | | |
| | mcb sp4_dr | 2 | I | | | | | | | | |
| | gpt10_pwm_evt | 3 | IO | | | | | | | | |
| | gpio_56 | 4 | IO | | | | | | | | |
| | safe_mode | 7 | | | | | | | | | |
| F3 | gpmc_ncs6 | 0 | O | H | H | 7 | vdds_mem | Yes | 4 | PU/ PD | LVC MOS |
| | sys_ndmareq3 | 1 | I | | | | | | | | |
| | mcb sp4_dx | 2 | IO | | | | | | | | |
| | gpt11_pwm_evt | 3 | IO | | | | | | | | |
| | gpio_57 | 4 | IO | | | | | | | | |
| | safe_mode | 7 | | | | | | | | | |
| G4 | gpmc_ncs7 | 0 | O | H | H | 7 | vdds_mem | Yes | 4 | PU/ PD | LVC MOS |
| | gpmc_io_dir | 1 | O | | | | | | | | |

Table 2-3. Ball Characteristics (CUS Pkg.) (continued)

| BALL BOTTOM [1] | BALL TOP [2] | PIN NAME [3] | MODE [4] | TYPE [5] | BALL RESET STATE [6] | BALL RESET REL. STATE [7] | RESET REL. MODE [8] | POWER [9] | HYS [10] | BUFFER STRENGTH (mA) [11] | PULLUP /DOWN TYPE [12] |
|-----------------|---------------|--------------|----------|----------|----------------------|---------------------------|---------------------|-----------|----------|---------------------------|------------------------|
| | mcbasp4_fsx | 2 | IO | | | | | | | | |
| | gpt8_pwm_evt | 3 | IO | | | | | | | | |
| | gpio_58 | 4 | IO | | | | | | | | |
| | safe_mode | 7 | | | | | | | | | |
| W2 | gpmc_clk | 0 | O | L | 0 | 0 | vdds_mem | Yes | 4 | PU/ PD | LVCMOS |
| | gpio_59 | 4 | IO | | | | | | | | |
| | safe_mode | 7 | | | | | | | | | |
| F1 | gpmc_nadv_ale | 0 | O | 0 | 0 | 0 | vdds_mem | No | 4 | NA | LVCMOS |
| F2 | gpmc_noe | 0 | O | 1 | 1 | 0 | vdds_mem | No | 4 | NA | LVCMOS |
| G3 | gpmc_nwe | 0 | O | 1 | 1 | 0 | vdds_mem | No | 4 | NA | LVCMOS |
| K5 | gpmc_nbe0_cke | 0 | O | L | 0 | 0 | vdds_mem | Yes | 4 | PU/ PD | LVCMOS |
| | gpio_60 | 4 | IO | | | | | | | | |
| | safe_mode | 7 | | | | | | | | | |
| L1 | gpmc_nbe1 | 0 | O | L | L | 7 | vdds_mem | Yes | 4 | PU/ PD | LVCMOS |
| | gpio_61 | 4 | IO | | | | | | | | |
| | safe_mode | 7 | | | | | | | | | |
| E1 | gpmc_nwp | 0 | O | L | 0 | 0 | vdds_mem | Yes | 4 | PU/ PD | LVCMOS |
| | gpio_62 | 4 | IO | | | | | | | | |
| | safe_mode | 7 | | | | | | | | | |
| C1 | gpmc_wait0 | 0 | I | H | H | 0 | vdds_mem | Yes | NA | PU/ PD | LVCMOS |
| C2 | gpmc_wait3 | 0 | I | H | H | 7 | vdds_mem | Yes | 4 | PU/ PD | LVCMOS |
| | sys_ndmareq1 | 1 | I | | | | | | | | |
| | gpio_65 | 4 | IO | | | | | | | | |
| | safe_mode | 7 | | | | | | | | | |
| G22 | dss_pclk | 0 | O | H | H | 7 | vdds | Yes | 4 | PU/ PD | LVCMOS |
| | gpio_66 | 4 | IO | | | | | | | | |
| | safe_mode | 7 | | | | | | | | | |
| E22 | dss_hsync | 0 | O | H | H | 7 | vdds | Yes | 4 | PU/ PD | LVCMOS |
| | gpio_67 | 4 | IO | | | | | | | | |
| | safe_mode | 7 | | | | | | | | | |
| F22 | dss_vsync | 0 | O | H | H | 7 | vdds | Yes | 4 | PU/ PD | LVCMOS |
| | gpio_68 | 4 | IO | | | | | | | | |
| | safe_mode | 7 | | | | | | | | | |
| J21 | dss_acbias | 0 | O | L | L | 7 | vdds | Yes | 8 | PU/ PD | LVCMOS |
| | gpio_69 | 4 | IO | | | | | | | | |
| | safe_mode | 7 | | | | | | | | | |
| AC19 | dss_data0 | 0 | IO | L | L | 7 | vdds | No | 4 | PU/ PD | LVCMOS |
| | uart1_cts | 2 | I | | | | | | | | |
| | gpio_70 | 4 | IO | | | | | | | | |
| | safe_mode | 7 | | | | | | | | | |
| AB19 | dss_data1 | 0 | IO | L | L | 7 | vdds | No | 4 | PU/ PD | LVCMOS |
| | uart1_rts | 2 | O | | | | | | | | |
| | gpio_71 | 4 | IO | | | | | | | | |
| | safe_mode | 7 | | | | | | | | | |
| AD20 | dss_data2 | 0 | IO | L | L | 7 | vdds | No | 4 | PU/ PD | LVCMOS |
| | gpio_72 | 4 | IO | | | | | | | | |
| | safe_mode | 7 | | | | | | | | | |
| AC20 | dss_data3 | 0 | IO | L | L | 7 | vdds | No | 4 | PU/ PD | LVCMOS |
| | gpio_73 | 4 | IO | | | | | | | | |
| | safe_mode | 7 | | | | | | | | | |
| AD21 | dss_data4 | 0 | IO | L | L | 7 | vdds | No | 4 | PU/ PD | LVCMOS |
| | uart3_rx_irrx | 2 | I | | | | | | | | |

Table 2-3. Ball Characteristics (CUS Pkg.) (continued)

| BALL BOTTOM [1] | BALL TOP [2] | PIN NAME [3] | MODE [4] | TYPE [5] | BALL RESET STATE [6] | BALL RESET REL. STATE [7] | RESET REL. MODE [8] | POWER [9] | HYS [10] | BUFFER STRENGTH (mA) [11] | PULLUP /DOWN TYPE [12] |
|-----------------|---------------|--------------|----------|----------|----------------------|---------------------------|---------------------|-----------|----------|---------------------------|------------------------|
| | gpio_74 | 4 | IO | | | | | | | | |
| | safe_mode | 7 | | | | | | | | | |
| AC21 | dss_data5 | 0 | IO | L | L | 7 | vdds | No | 4 | PU/ PD | LVC MOS |
| | uart3_tx_irtx | 2 | O | | | | | | | | |
| | gpio_75 | 4 | IO | | | | | | | | |
| | safe_mode | 7 | | | | | | | | | |
| D24 | dss_data6 | 0 | IO | L | L | 7 | vdds | Yes | 8 | PU/ PD | LVC MOS |
| | uart1_tx | 2 | O | | | | | | | | |
| | gpio_76 | 4 | IO | | | | | | | | |
| | safe_mode | 7 | | | | | | | | | |
| E23 | dss_data7 | 0 | IO | L | L | 7 | vdds | Yes | 8 | PU/ PD | LVC MOS |
| | uart1_rx | 2 | I | | | | | | | | |
| | gpio_77 | 4 | IO | | | | | | | | |
| | safe_mode | 7 | | | | | | | | | |
| E24 | dss_data8 | 0 | IO | L | L | 7 | vdds | Yes | 8 | PU/ PD | LVC MOS |
| | gpio_78 | 4 | IO | | | | | | | | |
| | safe_mode | 7 | | | | | | | | | |
| F23 | dss_data9 | 0 | IO | L | L | 7 | vdds | Yes | 8 | PU/ PD | LVC MOS |
| | gpio_79 | 4 | IO | | | | | | | | |
| | safe_mode | 7 | | | | | | | | | |
| AC22 | dss_data10 | 0 | IO | L | L | 7 | vdds | NA | 4 | PU/ PD | LVC MOS |
| | gpio_80 | 4 | IO | | | | | | | | |
| | safe_mode | 7 | | | | | | | | | |
| AC23 | dss_data11 | 0 | IO | L | L | 7 | vdds | NA | 4 | PU/ PD | LVC MOS |
| | gpio_81 | 4 | IO | | | | | | | | |
| | safe_mode | 7 | | | | | | | | | |
| AB22 | dss_data12 | 0 | IO | L | L | 7 | vdds | NA | 4 | PU/ PD | LVC MOS |
| | gpio_82 | 4 | IO | | | | | | | | |
| | safe_mode | 7 | | | | | | | | | |
| Y22 | dss_data13 | 0 | IO | L | L | 7 | vdds | NA | 4 | PU/ PD | LVC MOS |
| | gpio_83 | 4 | IO | | | | | | | | |
| | safe_mode | 7 | | | | | | | | | |
| W22 | dss_data14 | 0 | IO | L | L | 7 | vdds | NA | 4 | PU/ PD | LVC MOS |
| | gpio_84 | 4 | IO | | | | | | | | |
| | safe_mode | 7 | | | | | | | | | |
| V22 | dss_data15 | 0 | IO | L | L | 7 | vdds | NA | 4 | PU/ PD | LVC MOS |
| | gpio_85 | 4 | IO | | | | | | | | |
| | safe_mode | 7 | | | | | | | | | |
| J22 | dss_data16 | 0 | IO | L | L | 7 | vdds | Yes | 8 | PU/ PD | LVC MOS |
| | gpio_86 | 4 | IO | | | | | | | | |
| | safe_mode | 7 | | | | | | | | | |
| G23 | dss_data17 | 0 | IO | L | L | 7 | vdds | Yes | 8 | PU/ PD | LVC MOS |
| | gpio_87 | 4 | IO | | | | | | | | |
| | safe_mode | 7 | | | | | | | | | |
| G24 | dss_data18 | 0 | IO | L | L | 7 | vdds | Yes | 8 | PU/ PD | LVC MOS |
| | mcs pi3_clk | 2 | IO | | | | | | | | |
| | dss_data0 | 3 | IO | | | | | | | | |
| | gpio_88 | 4 | IO | | | | | | | | |
| | safe_mode | 7 | | | | | | | | | |
| H23 | dss_data19 | 0 | IO | L | L | 7 | vdds | Yes | 8 | PU/ PD | LVC MOS |
| | mcs pi3_simo | 2 | IO | | | | | | | | |
| | dss_data1 | 3 | IO | | | | | | | | |
| | gpio_89 | 4 | IO | | | | | | | | |
| | safe_mode | 7 | | | | | | | | | |

Table 2-3. Ball Characteristics (CUS Pkg.) (continued)

| BALL BOTTOM [1] | BALL TOP [2] | PIN NAME [3] | MODE [4] | TYPE [5] | BALL RESET STATE [6] | BALL RESET REL. STATE [7] | RESET REL. MODE [8] | POWER [9] | HYS [10] | BUFFER STRENGTH (mA) [11] | PULLUP /DOWN TYPE [12] |
|-----------------|------------------|--------------|----------|----------|----------------------|---------------------------|---------------------|-----------|----------|---------------------------|------------------------|
| D23 | dss_data20 | 0 | O | H | H | 7 | vdds | Yes | 4 | PU/ PD | LVCMOS |
| | mcspi3_somi | 2 | IO | | | | | | | | |
| | dss_data2 | 3 | IO | | | | | | | | |
| | gpio_90 | 4 | IO | | | | | | | | |
| | safe_mode | 7 | | | | | | | | | |
| K22 | dss_data21 | 0 | O | L | L | 7 | vdds | Yes | 8 | PU/ PD | LVCMOS |
| | mcspi3_cs0 | 2 | IO | | | | | | | | |
| | dss_data3 | 3 | IO | | | | | | | | |
| | gpio_91 | 4 | IO | | | | | | | | |
| | safe_mode | 7 | | | | | | | | | |
| V21 | dss_data22 | 0 | O | L | L | 7 | vdds | NA | 4 | PU/ PD | LVCMOS |
| | mcspi3_cs1 | 2 | O | | | | | | | | |
| | dss_data4 | 3 | IO | | | | | | | | |
| | gpio_92 | 4 | IO | | | | | | | | |
| | safe_mode | 7 | | | | | | | | | |
| W21 | dss_data23 | 0 | O | L | L | 7 | vdds | NA | 4 | PU/ PD | LVCMOS |
| | dss_data5 | 3 | IO | | | | | | | | |
| | gpio_93 | 4 | IO | | | | | | | | |
| | safe_mode | 7 | | | | | | | | | |
| AA23 | tv_out2 | 0 | O | Z | 0 | 0 | vdda_dac | | 8 | NA | 10-bit DAC |
| AB24 | tv_out1 | 0 | O | Z | 0 | 0 | vdda_dac | | 8 | NA | 10-bit DAC |
| AB23 | tv_vfb1 | 0 | O | Z | NA | 0 | vdda_dac | | | NA | 10-bit DAC |
| Y23 | tv_vfb2 | 0 | O | Z | NA | 0 | vdda_dac | | | NA | 10-bit DAC |
| Y24 | tv_vref | 0 | I | Z | NA | 0 | vdda_dac | | | NA | 10-bit DAC |
| A22 | cam_hs | 0 | IO | L | L | 7 | vdds | Yes | 4 | PU/ PD | LVCMOS |
| | gpio_94 | 4 | IO | | | | | | | | |
| | safe_mode | 7 | | | | | | | | | |
| E18 | cam_vs | 0 | IO | L | L | 7 | vdds | Yes | 4 | PU/ PD | LVCMOS |
| | gpio_95 | 4 | IO | | | | | | | | |
| | safe_mode | 7 | | | | | | | | | |
| B22 | cam_xclka | 0 | O | L | L | 7 | vdds | Yes | 4 | PU/ PD | LVCMOS |
| | gpio_96 | 4 | IO | | | | | | | | |
| | safe_mode | 7 | | | | | | | | | |
| J19 | cam_pclk | 0 | I | L | L | 7 | vdds | Yes | 4 | PU/ PD | LVCMOS |
| | gpio_97 | 4 | IO | | | | | | | | |
| | safe_mode | 7 | | | | | | | | | |
| H24 | cam_fld | 0 | IO | L | L | 7 | vdds | Yes | 4 | PU/ PD | LVCMOS |
| | cam_global_reset | 2 | IO | | | | | | | | |
| | gpio_98 | 4 | IO | | | | | | | | |
| | safe_mode | 7 | | | | | | | | | |
| AB18 | cam_d0 | 0 | I | L | L | 7 | vdds | Yes | 4 | PD | LVCMOS |
| | gpio_99 | 4 | I | | | | | | | | |
| | safe_mode | 7 | | | | | | | | | |
| AC18 | cam_d1 | 0 | I | L | L | 7 | vdds | Yes | 4 | PD | LVCMOS |
| | gpio_100 | 4 | I | | | | | | | | |
| | safe_mode | 7 | | | | | | | | | |
| G19 | cam_d2 | 0 | I | L | L | 7 | vdds | Yes | 4 | PU/ PD | LVCMOS |
| | gpio_101 | 4 | IO | | | | | | | | |
| | safe_mode | 7 | | | | | | | | | |
| F19 | cam_d3 | 0 | I | L | L | 7 | vdds | Yes | 4 | PU/ PD | LVCMOS |
| | gpio_102 | 4 | IO | | | | | | | | |
| | safe_mode | 7 | | | | | | | | | |
| G20 | cam_d4 | 0 | I | L | L | 7 | vdds | Yes | 4 | PU/ PD | LVCMOS |
| | gpio_103 | 4 | IO | | | | | | | | |

Table 2-3. Ball Characteristics (CUS Pkg.) (continued)

| BALL BOTTOM [1] | BALL TOP [2] | PIN NAME [3] | MODE [4] | TYPE [5] | BALL RESET STATE [6] | BALL RESET REL. STATE [7] | RESET REL. MODE [8] | POWER [9] | HYS [10] | BUFFER STRENGTH (mA) [11] | PULLUP /DOWN TYPE [12] |
|-----------------|--------------|--------------|----------|----------|----------------------|---------------------------|---------------------|-----------|------------------|---------------------------|------------------------|
| | safe_mode | 7 | | | | | | | | | |
| B21 | cam_d5 | 0 | I | L | L | 7 | vdds | Yes | 4 | PU/ PD | LVCMOS |
| | gpio_104 | 4 | IO | | | | | | | | |
| | safe_mode | 7 | | | | | | | | | |
| L24 | cam_d6 | 0 | I | L | L | 7 | vdds | NA | 4 | PD | LVCMOS |
| | gpio_105 | 4 | IO | | | | | | | | |
| | safe_mode | 7 | | | | | | | | | |
| K24 | cam_d7 | 0 | I | L | L | 7 | vdds | NA | 4 | PD | LVCMOS |
| | gpio_106 | 4 | IO | | | | | | | | |
| | safe_mode | 7 | | | | | | | | | |
| J23 | cam_d8 | 0 | I | L | L | 7 | vdds | NA | 4 | PD | LVCMOS |
| | gpio_107 | 4 | IO | | | | | | | | |
| | safe_mode | 7 | | | | | | | | | |
| K23 | cam_d9 | 0 | I | L | L | 7 | vdds | NA | 4 | PD | LVCMOS |
| | gpio_108 | 4 | IO | | | | | | | | |
| | safe_mode | 7 | | | | | | | | | |
| F21 | cam_d10 | 0 | I | L | L | 7 | vdds | Yes | 4 | PU/ PD | LVCMOS |
| | gpio_109 | 4 | IO | | | | | | | | |
| | safe_mode | 7 | | | | | | | | | |
| G21 | cam_d11 | 0 | I | L | L | 7 | vdds | Yes | 4 | PU/ PD | LVCMOS |
| | gpio_110 | 4 | IO | | | | | | | | |
| | safe_mode | 7 | | | | | | | | | |
| C22 | cam_xclkb | 0 | O | L | L | 7 | vdds | Yes | 4 | PU/ PD | LVCMOS |
| | gpio_111 | 4 | IO | | | | | | | | |
| | safe_mode | 7 | | | | | | | | | |
| F18 | cam_wen | 0 | I | L | L | 7 | vdds | Yes | 4 | PU/ PD | LVCMOS |
| | cam_shutter | 2 | O | | | | | | | | |
| | gpio_167 | 4 | IO | | | | | | | | |
| | safe_mode | 7 | | | | | | | | | |
| J20 | cam_strobe | 0 | O | L | L | 7 | vdds | Yes | 4 | PU/ PD | LVCMOS |
| | gpio_126 | 4 | IO | | | | | | | | |
| | safe_mode | 7 | | | | | | | | | |
| V20 | mcbasp2_fsx | 0 | IO | L | L | 7 | vdds | Yes | 4 ⁽¹⁾ | PU/ PD | LVCMOS |
| | gpio_116 | 4 | IO | | | | | | | | |
| | safe_mode | 7 | | | | | | | | | |
| T21 | mcbasp2_clkx | 0 | IO | L | L | 7 | vdds | Yes | 4 ⁽¹⁾ | PU/ PD | LVCMOS |
| | gpio_117 | 4 | IO | | | | | | | | |
| | safe_mode | 7 | | | | | | | | | |
| V19 | mcbasp2_dr | 0 | I | L | L | 7 | vdds | Yes | 4 ⁽¹⁾ | PU/ PD | LVCMOS |
| | gpio_118 | 4 | IO | | | | | | | | |
| | safe_mode | 7 | | | | | | | | | |
| R20 | mcbasp2_dx | 0 | IO | L | L | 7 | vdds | Yes | 4 ⁽¹⁾ | PU/ PD | LVCMOS |
| | gpio_119 | 4 | IO | | | | | | | | |
| | safe_mode | 7 | | | | | | | | | |
| M23 | mmc1_clk | 0 | O | L | L | 7 | vdds_mmc1 | Yes | 8 | PU/ PD | LVCMOS |
| | gpio_120 | 4 | IO | | | | | | | | |
| | safe_mode | 7 | | | | | | | | | |
| L23 | mmc1_cmd | 0 | IO | L | L | 7 | vdds_mmc1 | Yes | 8 | PU/ PD | LVCMOS |
| | gpio_121 | 4 | IO | | | | | | | | |
| | safe_mode | 7 | | | | | | | | | |
| M22 | mmc1_dat0 | 0 | IO | L | L | 7 | vdds_mmc1 | Yes | 8 | PU/ PD | LVCMOS |
| | gpio_122 | 4 | IO | | | | | | | | |
| | safe_mode | 7 | | | | | | | | | |

(1) The buffer strength of this IO cell is programmable (2, 4, 6, or 8 mA) according to the selected mode; the default value is described in

Table 2-3. Ball Characteristics (CUS Pkg.) (continued)

| BALL BOTTOM [1] | BALL TOP [2] | PIN NAME [3] | MODE [4] | TYPE [5] | BALL RESET STATE [6] | BALL RESET REL. STATE [7] | RESET REL. MODE [8] | POWER [9] | HYS [10] | BUFFER STRENGTH (mA) [11] | PULLUP /DOWN TYPE [12] |
|-----------------|------------------|--------------|----------|----------|----------------------|---------------------------|---------------------|-----------|----------|---------------------------|------------------------|
| M21 | mmc1_dat1 | 0 | IO | L | L | 7 | vdds_mmc1 | Yes | 8 | PU/ PD | LVCMOS |
| | gpio_123 | 4 | IO | | | | | | | | |
| | safe_mode | 7 | | | | | | | | | |
| M20 | mmc1_dat2 | 0 | IO | L | L | 7 | vdds_mmc1 | Yes | 8 | PU/ PD | LVCMOS |
| | gpio_124 | 4 | IO | | | | | | | | |
| | safe_mode | 7 | | | | | | | | | |
| N23 | mmc1_dat3 | 0 | IO | L | L | 7 | vdds_mmc1 | Yes | 8 | PU/ PD | LVCMOS |
| | gpio_125 | 4 | IO | | | | | | | | |
| | safe_mode | 7 | | | | | | | | | |
| N22 | mmc1_dat4 | 0 | IO | L | L | 7 | vdds_mmc1a | No | 8 | PD | LVCMOS |
| | gpio_126 | 4 | IO | | | | | | | | |
| | safe_mode | 7 | | | | | | | | | |
| N21 | mmc1_dat5 | 0 | IO | L | L | 7 | vdds_mmc1a | No | 8 | PD | LVCMOS |
| | gpio_127 | 4 | IO | | | | | | | | |
| | safe_mode | 7 | | | | | | | | | |
| N20 | mmc1_dat6 | 0 | IO | L | L | 7 | vdds_mmc1a | No | 8 | PD | LVCMOS |
| | gpio_128 | 4 | IO | | | | | | | | |
| | safe_mode | 7 | | | | | | | | | |
| P24 | mmc1_dat7 | 0 | IO | L | L | 7 | vdds_mmc1a | No | 8 | PD | LVCMOS |
| | gpio_129 | 4 | IO | | | | | | | | |
| | safe_mode | 7 | | | | | | | | | |
| Y1 | mmc2_clk | 0 | O | L | L | 7 | vdds | Yes | 4 | PU/ PD | LVCMOS |
| | mcspi3_clk | 1 | IO | | | | | | | | |
| | gpio_130 | 4 | IO | | | | | | | | |
| | safe_mode | 7 | | | | | | | | | |
| AB5 | mmc2_cmd | 0 | IO | H | H | 7 | vdds | Yes | 4 | PU/ PD | LVCMOS |
| | mcspi3_simo | 1 | IO | | | | | | | | |
| | gpio_131 | 4 | IO | | | | | | | | |
| | safe_mode | 7 | | | | | | | | | |
| AB3 | mmc2_dat0 | 0 | IO | H | H | 7 | vdds | Yes | 4 | PU/ PD | LVCMOS |
| | mcspi3_somi | 1 | IO | | | | | | | | |
| | gpio_132 | 4 | IO | | | | | | | | |
| | safe_mode | 7 | | | | | | | | | |
| Y3 | mmc2_dat1 | 0 | IO | H | H | 7 | vdds | Yes | 4 | PU/ PD | LVCMOS |
| | gpio_133 | 4 | IO | | | | | | | | |
| | safe_mode | 7 | | | | | | | | | |
| W3 | mmc2_dat2 | 0 | IO | H | H | 7 | vdds | Yes | 4 | PU/ PD | LVCMOS |
| | mcspi3_cs1 | 1 | O | | | | | | | | |
| | gpio_134 | 4 | IO | | | | | | | | |
| | safe_mode | 7 | | | | | | | | | |
| V3 | mmc2_dat3 | 0 | IO | H | H | 7 | vdds | Yes | 4 | PU/ PD | LVCMOS |
| | mcspi3_cs0 | 1 | IO | | | | | | | | |
| | gpio_135 | 4 | IO | | | | | | | | |
| | safe_mode | 7 | | | | | | | | | |
| AB2 | mmc2_dat4 | 0 | IO | L | L | 7 | vdds | Yes | 4 | PU/ PD | LVCMOS |
| | mmc2_dir_dat0 | 1 | O | | | | | | | | |
| | mmc3_dat0 | 3 | IO | | | | | | | | |
| | gpio_136 | 4 | IO | | | | | | | | |
| | safe_mode | 7 | | | | | | | | | |
| AA2 | mmc2_dat5 | 0 | IO | L | L | 7 | vdds | Yes | 4 | PU/ PD | LVCMOS |
| | mmc2_dir_dat1 | 1 | O | | | | | | | | |
| | cam_global_reset | 2 | IO | | | | | | | | |

Table 2-3. Ball Characteristics (CUS Pkg.) (continued)

| BALL BOTTOM [1] | BALL TOP [2] | PIN NAME [3] | MODE [4] | TYPE [5] | BALL RESET STATE [6] | BALL RESET REL. STATE [7] | RESET REL. MODE [8] | POWER [9] | HYS [10] | BUFFER STRENGTH (mA) [11] | PULLUP /DOWN TYPE [12] |
|-----------------|------------------|--------------|----------|----------|----------------------|---------------------------|---------------------|-----------|----------|---------------------------|------------------------|
| | mmc3_dat1 | 3 | IO | | | | | | | | |
| | gpio_137 | 4 | IO | | | | | | | | |
| | safe_mode | 7 | | | | | | | | | |
| Y2 | mmc2_dat6 | 0 | IO | L | L | 7 | vdds | Yes | 4 | PU/ PD | LVCMOS |
| | mmc2_dir_cmd | 1 | O | | | | | | | | |
| | cam_shutter | 2 | O | | | | | | | | |
| | mmc3_dat2 | 3 | IO | | | | | | | | |
| | gpio_138 | 4 | IO | | | | | | | | |
| | safe_mode | 7 | | | | | | | | | |
| AA1 | mmc2_dat7 | 0 | IO | L | L | 7 | vdds | Yes | 4 | PU/ PD | LVCMOS |
| | mmc2_clkin | 1 | I | | | | | | | | |
| | mmc3_dat3 | 3 | IO | | | | | | | | |
| | gpio_139 | 4 | IO | | | | | | | | |
| | safe_mode | 7 | | | | | | | | | |
| V6 | mcbasp3_dx | 0 | IO | L | L | 7 | vdds | Yes | 4 | PU/ PD | LVCMOS |
| | uart2_cts | 1 | I | | | | | | | | |
| | gpio_140 | 4 | IO | | | | | | | | |
| | safe_mode | 7 | | | | | | | | | |
| V5 | mcbasp3_dir | 0 | I | L | L | 7 | vdds | Yes | 4 | PU/ PD | LVCMOS |
| | uart2_rts | 1 | O | | | | | | | | |
| | gpio_141 | 4 | IO | | | | | | | | |
| | safe_mode | 7 | | | | | | | | | |
| W4 | mcbasp3_clkx | 0 | IO | L | L | 7 | vdds | Yes | 4 | PU/ PD | LVCMOS |
| | uart2_tx | 1 | O | | | | | | | | |
| | gpio_142 | 4 | IO | | | | | | | | |
| | safe_mode | 7 | | | | | | | | | |
| V4 | mcbasp3_fsx | 0 | IO | L | L | 7 | vdds | Yes | 4 | PU/ PD | LVCMOS |
| | uart2_rx | 1 | I | | | | | | | | |
| | gpio_143 | 4 | IO | | | | | | | | |
| | safe_mode | 7 | | | | | | | | | |
| W7 | uart1_tx | 0 | O | L | L | 7 | vdds | Yes | 4 | PU/ PD | LVCMOS |
| | gpio_148 | 4 | IO | | | | | | | | |
| | safe_mode | 7 | | | | | | | | | |
| W6 | uart1_rts | 0 | O | L | L | 7 | vdds | Yes | 4 | PU/ PD | LVCMOS |
| | gpio_149 | 4 | IO | | | | | | | | |
| | safe_mode | 7 | | | | | | | | | |
| AC2 | uart1_cts | 0 | I | L | L | 7 | vdds | Yes | 4 | PU/ PD | LVCMOS |
| | gpio_150 | 4 | IO | | | | | | | | |
| | safe_mode | 7 | | | | | | | | | |
| V7 | uart1_rx | 0 | I | L | L | 7 | vdds | Yes | 4 | PU/ PD | LVCMOS |
| | mcbasp1_clk | 2 | IO | | | | | | | | |
| | mcspi4_clk | 3 | IO | | | | | | | | |
| | gpio_151 | 4 | IO | | | | | | | | |
| | safe_mode | 7 | | | | | | | | | |
| W19 | mcbasp1_clk | 0 | IO | L | L | 7 | vdds | Yes | 4 | PU/ PD | LVCMOS |
| | mcspi4_clk | 1 | IO | | | | | | | | |
| | gpio_156 | 4 | IO | | | | | | | | |
| | safe_mode | 7 | | | | | | | | | |
| AB20 | mcbasp1_fsr | 0 | IO | L | L | 7 | vdds | Yes | 4 | PU/ PD | LVCMOS |
| | cam_global_reset | 2 | IO | | | | | | | | |
| | gpio_157 | 4 | IO | | | | | | | | |
| | safe_mode | 7 | | | | | | | | | |
| W18 | mcbasp1_dx | 0 | IO | L | L | 7 | vdds | Yes | 4 | PU/ PD | LVCMOS |

Table 2-3. Ball Characteristics (CUS Pkg.) (continued)

| BALL BOTTOM [1] | BALL TOP [2] | PIN NAME [3] | MODE [4] | TYPE [5] | BALL RESET STATE [6] | BALL RESET REL. STATE [7] | RESET REL. MODE [8] | POWER [9] | HYS [10] | BUFFER STRENGTH (mA) [11] | PULLUP /DOWN TYPE [12] |
|-----------------|----------------|--------------|----------|----------|----------------------|---------------------------|---------------------|-----------|----------|---------------------------|------------------------|
| | mcspi4_simo | 1 | IO | | | | | | | | |
| | mcbasp3_dx | 2 | IO | | | | | | | | |
| | gpio_158 | 4 | IO | | | | | | | | |
| | safe_mode | 7 | | | | | | | | | |
| Y18 | mcbasp1_dr | 0 | I | L | L | 7 | vdds | Yes | 4 | PU/ PD | LVC MOS |
| | mcspi4_somi | 1 | IO | | | | | | | | |
| | mcbasp3_dr | 2 | O | | | | | | | | |
| | gpio_159 | 4 | IO | | | | | | | | |
| | safe_mode | 7 | | | | | | | | | |
| AA18 | mcbasp_clks | 0 | I | L | L | 7 | vdds | Yes | 4 | PU/ PD | LVC MOS |
| | cam_shutter | 2 | O | | | | | | | | |
| | gpio_160 | 4 | IO | | | | | | | | |
| | uart1_cts | 5 | I | | | | | | | | |
| | safe_mode | 7 | | | | | | | | | |
| AA19 | mcbasp1_fsx | 0 | IO | L | L | 7 | vdds | Yes | 4 | PU/ PD | LVC MOS |
| | mcspi4_cs0 | 1 | IO | | | | | | | | |
| | mcbasp3_fsx | 2 | IO | | | | | | | | |
| | gpio_161 | 4 | IO | | | | | | | | |
| | safe_mode | 7 | | | | | | | | | |
| V18 | mcbasp1_clkx | 0 | IO | L | L | 7 | vdds | Yes | 4 | PU/ PD | LVC MOS |
| | mcbasp3_clkx | 2 | IO | | | | | | | | |
| | gpio_162 | 4 | IO | | | | | | | | |
| | safe_mode | 7 | | | | | | | | | |
| A23 | uart3_cts_rctx | 0 | IO | H | H | 7 | vdds | Yes | 4 | PU/ PD | LVC MOS |
| | gpio_163 | 4 | IO | | | | | | | | |
| | safe_mode | 7 | | | | | | | | | |
| B23 | uart3_rts_sd | 0 | O | H | H | 7 | vdds | Yes | 4 | PU/ PD | LVC MOS |
| | gpio_164 | 4 | IO | | | | | | | | |
| | safe_mode | 7 | | | | | | | | | |
| B24 | uart3_rx_irrx | 0 | I | H | H | 7 | vdds | Yes | 4 | PU/ PD | LVC MOS |
| | gpio_165 | 4 | IO | | | | | | | | |
| | safe_mode | 7 | | | | | | | | | |
| C23 | uart3_tx_irtx | 0 | O | H | H | 7 | vdds | Yes | 4 | PU/ PD | LVC MOS |
| | gpio_166 | 4 | IO | | | | | | | | |
| | safe_mode | 7 | | | | | | | | | |
| R21 | hsusb0_clk | 0 | I | L | L | 7 | vdds | Yes | 4 | PU/ PD | LVC MOS |
| | gpio_120 | 4 | IO | | | | | | | | |
| | safe_mode | 7 | | | | | | | | | |
| R23 | hsusb0_stp | 0 | O | H | H | 7 | vdds | Yes | 4 | PU/ PD | LVC MOS |
| | gpio_121 | 4 | IO | | | | | | | | |
| | safe_mode | 7 | | | | | | | | | |
| P23 | hsusb0_dir | 0 | I | L | L | 7 | vdds | Yes | 4 | PU/ PD | LVC MOS |
| | gpio_122 | 4 | IO | | | | | | | | |
| | safe_mode | 7 | | | | | | | | | |
| R22 | hsusb0_nxt | 0 | I | L | L | 7 | vdds | Yes | 4 | PU/ PD | LVC MOS |
| | gpio_124 | 4 | IO | | | | | | | | |
| | safe_mode | 7 | | | | | | | | | |
| T24 | hsusb0_data0 | 0 | IO | L | L | 7 | vdds | Yes | 4 | PU/ PD | LVC MOS |
| | uart3_tx_irtx | 2 | O | | | | | | | | |
| | gpio_125 | 4 | IO | | | | | | | | |
| | safe_mode | 7 | | | | | | | | | |
| T23 | hsusb0_data1 | 0 | IO | L | L | 7 | vdds | Yes | 4 | PU/ PD | LVC MOS |
| | uart3_rx_irrx | 2 | I | | | | | | | | |
| | gpio_130 | 4 | IO | | | | | | | | |

Table 2-3. Ball Characteristics (CUS Pkg.) (continued)

| BALL BOTTOM [1] | BALL TOP [2] | PIN NAME [3] | MODE [4] | TYPE [5] | BALL RESET STATE [6] | BALL RESET REL. STATE [7] | RESET REL. MODE [8] | POWER [9] | HYS [10] | BUFFER STRENGTH (mA) [11] | PULLUP /DOWN TYPE [12] |
|-----------------|----------------|--------------|----------|----------|----------------------|---------------------------|---------------------|-----------|------------------|---------------------------|------------------------|
| | safe_mode | 7 | | | | | | | | | |
| U24 | hsusb0_data2 | 0 | IO | L | L | 7 | vdds | Yes | 4 | PU/ PD | LVCMOS |
| | uart3_rts_sd | 2 | O | | | | | | | | |
| | gpio_131 | 4 | IO | | | | | | | | |
| | safe_mode | 7 | | | | | | | | | |
| U23 | hsusb0_data3 | 0 | IO | L | L | 7 | vdds | Yes | 4 | PU/ PD | LVCMOS |
| | uart3_cts_rctx | 2 | IO | | | | | | | | |
| | gpio_169 | 4 | IO | | | | | | | | |
| | safe_mode | 7 | | | | | | | | | |
| W24 | hsusb0_data4 | 0 | IO | L | L | 7 | vdds | Yes | 4 | PU/ PD | LVCMOS |
| | gpio_188 | 4 | IO | | | | | | | | |
| | safe_mode | 7 | | | | | | | | | |
| V23 | hsusb0_data5 | 0 | IO | L | L | 7 | vdds | Yes | 4 | PU/ PD | LVCMOS |
| | gpio_189 | 4 | IO | | | | | | | | |
| | safe_mode | 7 | | | | | | | | | |
| W23 | hsusb0_data6 | 0 | IO | L | L | 7 | vdds | Yes | 4 | PU/ PD | LVCMOS |
| | gpio_190 | 4 | IO | | | | | | | | |
| | safe_mode | 7 | | | | | | | | | |
| T22 | hsusb0_data7 | 0 | IO | L | L | 7 | vdds | Yes | 4 | PU/ PD | LVCMOS |
| | gpio_191 | 4 | IO | | | | | | | | |
| | safe_mode | 7 | | | | | | | | | |
| K20 | i2c1_scl | 0 | IOD | H | H | 0 | vdds | Yes | 4 | PU/ PD | Open Drain |
| K21 | i2c1_sda | 0 | IOD | H | H | 0 | vdds | Yes | 4 | PU/ PD | Open Drain |
| AC15 | i2c2_scl | 0 | IOD | H | H | 7 | vdds | Yes | 4 | PU/ PD | Open Drain |
| | gpio_168 | 4 | IO | | | | | | | | |
| | safe_mode | 7 | | | | | | | | | |
| AC14 | i2c2_sda | 0 | IOD | H | H | 7 | vdds | Yes | 4 | PU/ PD | Open Drain |
| | gpio_183 | 4 | IO | | | | | | | | |
| | safe_mode | 7 | | | | | | | | | |
| AC13 | i2c3_scl | 0 | IOD | H | H | 7 | vdds | Yes | 4 | PU/ PD | Open Drain |
| | gpio_184 | 4 | IO | | | | | | | | |
| | safe_mode | 7 | | | | | | | | | |
| AC12 | i2c3_sda | 0 | IOD | H | H | 7 | vdds | Yes | 4 | PU/ PD | Open Drain |
| | gpio_185 | 4 | IO | | | | | | | | |
| | safe_mode | 7 | | | | | | | | | |
| Y16 | i2c4_scl | 0 | IOD | H | H | 0 | vdds | Yes | 4 | PU/ PD | Open Drain |
| | sys_nvmode1 | 1 | O | | | | | | | | |
| | safe_mode | 7 | | | | | | | | | |
| Y15 | i2c4_sda | 0 | IOD | H | H | 0 | vdds | Yes | 4 | PU/ PD | Open Drain |
| | sys_nvmode2 | 1 | O | | | | | | | | |
| | safe_mode | 7 | | | | | | | | | |
| A24 | hdq_sio | 0 | IOD | H | H | 7 | vdds | Yes | 4 | PU/ PD | LVCMOS |
| | sys_altclk | 1 | I | | | | | | | | |
| | i2c2_sccb2 | 2 | O | | | | | | | | |
| | i2c3_sccb2 | 3 | O | | | | | | | | |
| | gpio_170 | 4 | IO | | | | | | | | |
| | safe_mode | 7 | | | | | | | | | |
| T5 | mcspi1_clk | 0 | IO | L | L | 7 | vdds | Yes | 4 ⁽¹⁾ | PU/ PD | LVCMOS |
| | mmc2_dat4 | 1 | IO | | | | | | | | |
| | gpio_171 | 4 | IO | | | | | | | | |
| | safe_mode | 7 | | | | | | | | | |
| R4 | mcspi1_simo | 0 | IO | L | L | 7 | vdds | Yes | 4 ⁽¹⁾ | PU/ PD | LVCMOS |
| | mmc2_dat5 | 1 | IO | | | | | | | | |
| | gpio_172 | 4 | IO | | | | | | | | |

Table 2-3. Ball Characteristics (CUS Pkg.) (continued)

| BALL BOTTOM [1] | BALL TOP [2] | PIN NAME [3] | MODE [4] | TYPE [5] | BALL RESET STATE [6] | BALL RESET REL. STATE [7] | RESET REL. MODE [8] | POWER [9] | HYS [10] | BUFFER STRENGTH (mA) [11] | PULLUP /DOWN TYPE [12] |
|-----------------|------------------|--------------|----------|----------|----------------------|---------------------------|---------------------|-----------|------------------|---------------------------|------------------------|
| | safe_mode | 7 | | | | | | | | | |
| T4 | mcspi1_somi | 0 | IO | L | L | 7 | vdds | Yes | 4 ⁽¹⁾ | PU/ PD | LVC MOS |
| | mmc2_dat6 | 1 | IO | | | | | | | | |
| | gpio_173 | 4 | IO | | | | | | | | |
| | safe_mode | 7 | | | | | | | | | |
| T6 | mcspi1_cs0 | 0 | IO | H | H | 7 | vdds | Yes | 4 ⁽¹⁾ | PU/ PD | LVC MOS |
| | mmc2_dat7 | 1 | IO | | | | | | | | |
| | gpio_174 | 4 | IO | | | | | | | | |
| | safe_mode | 7 | | | | | | | | | |
| R5 | mcspi1_cs3 | 0 | O | H | H | 7 | vdds | Yes | 4 | PU/ PD | LVC MOS |
| | hsusb2_tll_data2 | 2 | IO | | | | | | | | |
| | hsusb2_data2 | 3 | IO | | | | | | | | |
| | gpio_177 | 4 | IO | | | | | | | | |
| | mm2_txdat | 5 | IO | | | | | | | | |
| | safe_mode | 7 | | | | | | | | | |
| N5 | mcspi2_clk | 0 | IO | L | L | 7 | vdds | Yes | 4 | PU/ PD | LVC MOS |
| | hsusb2_tll_data7 | 2 | IO | | | | | | | | |
| | hsusb2_data7 | 3 | O | | | | | | | | |
| | gpio_178 | 4 | IO | | | | | | | | |
| | safe_mode | 7 | | | | | | | | | |
| N4 | mcspi2_simo | 0 | IO | L | L | 7 | vdds | Yes | 4 | PU/ PD | LVC MOS |
| | gpt9_pwm_evt | 1 | IO | | | | | | | | |
| | hsusb2_tll_data4 | 2 | IO | | | | | | | | |
| | hsusb2_data4 | 3 | I | | | | | | | | |
| | gpio_179 | 4 | IO | | | | | | | | |
| | safe_mode | 7 | | | | | | | | | |
| N3 | mcspi2_somi | 0 | IO | L | L | 7 | vdds | Yes | 4 | PU/ PD | LVC MOS |
| | gpt10_pwm_evt | 1 | IO | | | | | | | | |
| | hsusb2_tll_data5 | 2 | IO | | | | | | | | |
| | hsusb2_data5 | 3 | O | | | | | | | | |
| | gpio_180 | 4 | IO | | | | | | | | |
| | safe_mode | 7 | | | | | | | | | |
| M5 | mcspi2_cs0 | 0 | IO | H | H | 7 | vdds | Yes | 4 | PU/ PD | LVC MOS |
| | gpt11_pwm_evt | 1 | IO | | | | | | | | |
| | hsusb2_tll_data6 | 2 | IO | | | | | | | | |
| | hsusb2_data6 | 3 | O | | | | | | | | |
| | gpio_181 | 4 | IO | | | | | | | | |
| | safe_mode | 7 | | | | | | | | | |
| M4 | mcspi2_cs1 | 0 | O | L | L | 7 | vdds | Yes | 4 | PU/ PD | LVC MOS |
| | gpt8_pwm_evt | 1 | IO | | | | | | | | |
| | hsusb2_tll_data3 | 2 | IO | | | | | | | | |
| | hsusb2_data3 | 3 | IO | | | | | | | | |
| | gpio_182 | 4 | IO | | | | | | | | |
| | mm2_txen_n | 5 | IO | | | | | | | | |
| | safe_mode | 7 | | | | | | | | | |
| AA16 | sys_32k | 0 | I | Z | I | NA | vdds | Yes | NA | NA | LVC MOS |
| AD15 | sys_xtalin | 0 | I | Z | I | NA | vdds | Yes | | NA | LVC MOS |
| AD14 | sys_xtalout | 0 | O | Z | O | NA | vdds | Yes | | NA | LVC MOS |
| Y13 | sys_clkreq | 0 | IO | 0 | 1 | 0 | vdds | Yes | 4 | PU/ PD | LVC MOS |

Table 2-3. Ball Characteristics (CUS Pkg.) (continued)

| BALL BOTTOM [1] | BALL TOP [2] | PIN NAME [3] | MODE [4] | TYPE [5] | BALL RESET STATE [6] | BALL RESET REL. STATE [7] | RESET REL. MODE [8] | POWER [9] | HYS [10] | BUFFER STRENGTH (mA) [11] | PULLUP /DOWN TYPE [12] |
|-----------------|----------------|--------------|----------|----------|----------------------|---------------------------|---------------------|-----------|----------|---------------------------|------------------------|
| | gpio_1 | 4 | IO | | | | | | | | |
| | safe_mode | 7 | | | | | | | | | |
| W16 | sys_nirq | 0 | I | H | H | 7 | vdds | Yes | 4 | PU/ PD | LVC MOS |
| | gpio_0 | 4 | IO | | | | | | | | |
| | safe_mode | 7 | | | | | | | | | |
| AA10 | sys_nrespwron | 0 | I | Z | I | NA | vdds | Yes | NA | NA | LVC MOS |
| Y10 | sys_nreswarm | 0 | IOD | 0 | 1 (PU) | 0 | vdds | Yes | 4 | PU/ PD | LVC MOS |
| | gpio_30 | 4 | IO | | | | | | | | |
| | safe_mode | 7 | | | | | | | | | |
| AB12 | sys_boot0 | 0 | I | Z | Z | 0 | vdds | Yes | 4 | PU/ PD | LVC MOS |
| | gpio_2 | 4 | IO | | | | | | | | |
| | safe_mode | 7 | | | | | | | | | |
| AC16 | sys_boot1 | 0 | I | Z | Z | 0 | vdds | Yes | 4 | PU/ PD | LVC MOS |
| | gpio_3 | 4 | IO | | | | | | | | |
| | safe_mode | 7 | | | | | | | | | |
| AD17 | sys_boot2 | 0 | I | Z | Z | 0 | vdds | Yes | 4 | PU/ PD | LVC MOS |
| | gpio_4 | 4 | IO | | | | | | | | |
| | safe_mode | 7 | | | | | | | | | |
| AD18 | sys_boot3 | 0 | I | Z | Z | 0 | vdds | Yes | 4 | PU/ PD | LVC MOS |
| | gpio_5 | 4 | IO | | | | | | | | |
| | safe_mode | 7 | | | | | | | | | |
| AC17 | sys_boot4 | 0 | I | Z | Z | 0 | vdds | Yes | 4 | PU/ PD | LVC MOS |
| | mmc2_dir_dat 2 | 1 | O | | | | | | | | |
| | gpio_6 | 4 | IO | | | | | | | | |
| | safe_mode | 7 | | | | | | | | | |
| AB16 | sys_boot5 | 0 | I | Z | Z | 0 | vdds | Yes | 4 | PU/ PD | LVC MOS |
| | mmc2_dir_dat 3 | 1 | O | | | | | | | | |
| | gpio_7 | 4 | IO | | | | | | | | |
| | safe_mode | 7 | | | | | | | | | |
| AA15 | sys_boot6 | 0 | I | Z | Z | 0 | vdds | Yes | 4 | PU/ PD | LVC MOS |
| | gpio_8 | 4 | IO | | | | | | | | |
| | safe_mode | 7 | | | | | | | | | |
| AD23 | sys_off_mode | 0 | O | 0 | L | 7 | vdds | Yes | 4 | PU/ PD | LVC MOS |
| | gpio_9 | 4 | IO | | | | | | | | |
| | safe_mode | 7 | | | | | | | | | |
| Y7 | sys_clkout1 | 0 | O | L | L | 7 | vdds | Yes | 4 | PU/ PD | LVC MOS |
| | gpio_10 | 4 | IO | | | | | | | | |
| | safe_mode | 7 | | | | | | | | | |
| AA6 | sys_clkout2 | 0 | O | L | L | 7 | vdds | Yes | 4 | PU/ PD | LVC MOS |
| | gpio_186 | 4 | IO | | | | | | | | |
| | safe_mode | 7 | | | | | | | | | |
| AB7 | jtag_nrst | 0 | I | L | L | 0 | vdds | Yes | NA | PU/ PD | LVC MOS |
| AB6 | jtag_tck | 0 | I | L | L | 0 | vdds | Yes | NA | PU/ PD | LVC MOS |
| AA7 | jtag_rtck | 0 | O | L | 0 | 0 | vdds | Yes | 4 | PU/ PD | LVC MOS |
| AA9 | jtag_tms_tmsc | 0 | IO | H | H | 0 | vdds | Yes | 4 | PU/ PD | LVC MOS |
| AB10 | jtag_tdi | 0 | I | H | H | 0 | vdds | Yes | NA | PU/ PD | LVC MOS |
| AB9 | jtag_tdo | 0 | O | L | Z | 0 | vdds | Yes | 4 | PU/ PD | LVC MOS |
| AC24 | jtag_emu0 | 0 | IO | H | H | 0 | vdds | Yes | 4 | PU/ PD | LVC MOS |
| | gpio_11 | 4 | IO | | | | | | | | |
| | safe_mode | 7 | | | | | | | | | |
| AD24 | jtag_emu1 | 0 | IO | H | H | 0 | vdds | Yes | 4 | PU/ PD | LVC MOS |
| | gpio_31 | 4 | IO | | | | | | | | |

Table 2-3. Ball Characteristics (CUS Pkg.) (continued)

| BALL BOTTOM [1] | BALL TOP [2] | PIN NAME [3] | MODE [4] | TYPE [5] | BALL RESET STATE [6] | BALL RESET REL. STATE [7] | RESET REL. MODE [8] | POWER [9] | HYS [10] | BUFFER STRENGTH (mA) [11] | PULLUP /DOWN TYPE [12] |
|-----------------|------------------|--------------|----------|----------|----------------------|---------------------------|---------------------|-----------|----------|---------------------------|------------------------|
| | safe_mode | 7 | | | | | | | | | |
| AC1 | etk_clk | 0 | O | H | H | 4 | vdds | Yes | 4 | PU/ PD | LVC MOS |
| | mcbsp5_clkx | 1 | IO | | | | | | | | |
| | mmc3_clk | 2 | O | | | | | | | | |
| | hsusb1_stp | 3 | O | | | | | | | | |
| | gpio_12 | 4 | IO | | | | | | | | |
| | mm1_rxdp | 5 | IO | | | | | | | | |
| | hsusb1_tll_stp | 6 | I | | | | | | | | |
| AD3 | etk_ctl | 0 | O | H | H | 4 | vdds | Yes | 4 | PU/ PD | LVC MOS |
| | mmc3_cmd | 2 | IO | | | | | | | | |
| | hsusb1_clk | 3 | O | | | | | | | | |
| | gpio_13 | 4 | IO | | | | | | | | |
| | hsusb1_tll_clk | 6 | O | | | | | | | | |
| AD6 | etk_d0 | 0 | O | H | H | 4 | vdds | Yes | 4 | PU/ PD | LVC MOS |
| | mcspi3_simo | 1 | IO | | | | | | | | |
| | mmc3_dat4 | 2 | IO | | | | | | | | |
| | hsusb1_data0 | 3 | IO | | | | | | | | |
| | gpio_14 | 4 | IO | | | | | | | | |
| | mm1_rxcv | 5 | IO | | | | | | | | |
| | hsusb1_tll_data0 | 6 | IO | | | | | | | | |
| AC6 | etk_d1 | 0 | O | H | H | 4 | vdds | Yes | 4 | PU/ PD | LVC MOS |
| | mcspi3_somi | 1 | IO | | | | | | | | |
| | hsusb1_data1 | 3 | IO | | | | | | | | |
| | gpio_15 | 4 | IO | | | | | | | | |
| | mm1_txse0 | 5 | IO | | | | | | | | |
| | hsusb1_tll_data1 | 6 | IO | | | | | | | | |
| AC7 | etk_d2 | 0 | O | H | H | 4 | vdds | Yes | 4 | PU/ PD | LVC MOS |
| | mcspi3_cs0 | 1 | IO | | | | | | | | |
| | hsusb1_data2 | 3 | IO | | | | | | | | |
| | gpio_16 | 4 | IO | | | | | | | | |
| | mm1_txdat | 5 | IO | | | | | | | | |
| | hsusb1_tll_data2 | 6 | IO | | | | | | | | |
| AD8 | etk_d3 | 0 | O | H | H | 4 | vdds | Yes | 4 | PU/ PD | LVC MOS |
| | mcspi3_clk | 1 | IO | | | | | | | | |
| | mmc3_dat3 | 2 | IO | | | | | | | | |
| | hsusb1_data7 | 3 | IO | | | | | | | | |
| | gpio_17 | 4 | IO | | | | | | | | |
| | hsusb1_tll_data7 | 6 | IO | | | | | | | | |
| AC5 | etk_d4 | 0 | O | L | L | 4 | vdds | Yes | 4 | PU/ PD | LVC MOS |
| | mcbsp5_dr | 1 | I | | | | | | | | |
| | mmc3_dat0 | 2 | IO | | | | | | | | |
| | hsusb1_data4 | 3 | IO | | | | | | | | |
| | gpio_18 | 4 | IO | | | | | | | | |
| | hsusb1_tll_data4 | 6 | IO | | | | | | | | |
| AD2 | etk_d5 | 0 | O | L | L | 4 | vdds | Yes | 4 | PU/ PD | LVC MOS |
| | mcbsp5_fsx | 1 | IO | | | | | | | | |
| | mmc3_dat1 | 2 | IO | | | | | | | | |
| | hsusb1_data5 | 3 | IO | | | | | | | | |
| | gpio_19 | 4 | IO | | | | | | | | |
| | hsusb1_tll_data5 | 6 | IO | | | | | | | | |
| AC8 | etk_d6 | 0 | O | L | L | 4 | vdds | Yes | 4 | PU/ PD | LVC MOS |

Table 2-3. Ball Characteristics (CUS Pkg.) (continued)

| BALL BOTTOM [1] | BALL TOP [2] | PIN NAME [3] | MODE [4] | TYPE [5] | BALL RESET STATE [6] | BALL RESET REL. STATE [7] | RESET REL. MODE [8] | POWER [9] | HYS [10] | BUFFER STRENGTH (mA) [11] | PULLUP /DOWN TYPE [12] |
|-----------------|----------------------|--------------|----------|----------|----------------------|---------------------------|---------------------|-----------|----------|---------------------------|------------------------|
| | mcbasp5_dx | 1 | IO | | | | | | | | |
| | mmc3_dat2 | 2 | IO | | | | | | | | |
| | hsusb1_data6 | 3 | IO | | | | | | | | |
| | gpio_20 | 4 | IO | | | | | | | | |
| | hsusb1_tll_data6 | 6 | IO | | | | | | | | |
| AD9 | etk_d7 | 0 | O | L | L | 4 | vdds | Yes | 4 | PU/ PD | LVC MOS |
| | mcs pi3_cs1 | 1 | O | | | | | | | | |
| | mmc3_dat7 | 2 | IO | | | | | | | | |
| | hsusb1_data3 | 3 | IO | | | | | | | | |
| | gpio_21 | 4 | IO | | | | | | | | |
| | mm1_txen_n | 5 | IO | | | | | | | | |
| | hsusb1_tll_data3 | 6 | IO | | | | | | | | |
| AC4 | etk_d8 | 0 | O | L | L | 4 | vdds | Yes | 4 | PU/ PD | LVC MOS |
| | sys_drm_msecure | 1 | O | | | | | | | | |
| | mmc3_dat6 | 2 | IO | | | | | | | | |
| | hsusb1_dir | 3 | I | | | | | | | | |
| | gpio_22 | 4 | IO | | | | | | | | |
| | hsusb1_tll_dir | 6 | O | | | | | | | | |
| AD5 | etk_d9 | 0 | O | L | L | 4 | vdds | Yes | 4 | PU/ PD | LVC MOS |
| | sys_secure_indicator | 1 | O | | | | | | | | |
| | mmc3_dat5 | 2 | IO | | | | | | | | |
| | hsusb1_nxt | 3 | I | | | | | | | | |
| | gpio_23 | 4 | IO | | | | | | | | |
| | mm1_rxdm | 5 | IO | | | | | | | | |
| | hsusb1_tll_nxt | 6 | O | | | | | | | | |
| AC3 | etk_d10 | 0 | O | L | L | 4 | vdds | Yes | 4 | PU/ PD | LVC MOS |
| | uart1_rx | 2 | I | | | | | | | | |
| | hsusb2_clk | 3 | O | | | | | | | | |
| | gpio_24 | 4 | IO | | | | | | | | |
| | hsusb2_tll_clk | 6 | O | | | | | | | | |
| AC9 | etk_d11 | 0 | O | L | L | 4 | vdds | Yes | 4 | PU/ PD | LVC MOS |
| | hsusb2_stp | 3 | O | | | | | | | | |
| | gpio_25 | 4 | IO | | | | | | | | |
| | mm2_rxdp | 5 | IO | | | | | | | | |
| | hsusb2_tll_stp | 6 | I | | | | | | | | |
| AC10 | etk_d12 | 0 | O | L | L | 4 | vdds | Yes | 4 | PU/ PD | LVC MOS |
| | hsusb2_dir | 3 | I | | | | | | | | |
| | gpio_26 | 4 | IO | | | | | | | | |
| | hsusb2_tll_dir | 6 | O | | | | | | | | |
| AD11 | etk_d13 | 0 | O | L | L | 4 | vdds | Yes | 4 | PU/ PD | LVC MOS |
| | hsusb2_nxt | 3 | I | | | | | | | | |
| | gpio_27 | 4 | IO | | | | | | | | |
| | mm2_rxdm | 5 | IO | | | | | | | | |
| | hsusb2_tll_nxt | 6 | O | | | | | | | | |
| AC11 | etk_d14 | 0 | O | L | L | 4 | vdds | Yes | 4 | PU/ PD | LVC MOS |
| | hsusb2_data0 | 3 | IO | | | | | | | | |
| | gpio_28 | 4 | IO | | | | | | | | |
| | mm2_rxcv | 5 | IO | | | | | | | | |
| | hsusb2_tll_data0 | 6 | IO | | | | | | | | |
| AD12 | etk_d15 | 0 | O | L | L | 4 | vdds | Yes | 4 | PU/ PD | LVC MOS |
| | hsusb2_data1 | 3 | IO | | | | | | | | |

Table 2-3. Ball Characteristics (CUS Pkg.) (continued)

| BALL BOTTOM [1] | BALL TOP [2] | PIN NAME [3] | MODE [4] | TYPE [5] | BALL RESET STATE [6] | BALL RESET REL. STATE [7] | RESET REL. MODE [8] | POWER [9] | HYS [10] | BUFFER STRENGTH (mA) [11] | PULLUP /DOWN TYPE [12] |
|--|---|--------------|----------|----------|----------------------|---------------------------|---------------------|-----------|----------|---------------------------|------------------------|
| | gpio_29 | 4 | IO | | | | | | | | |
| | mm2_txse0 | 5 | IO | | | | | | | | |
| | hsusb2_tll_data1 | 6 | IO | | | | | | | | |
| E16, F15, F16, G15, G16, H15, J6, J7, J8, K6, K7, K8 | vdds_mem | 0 | PWR | - | - | - | - | - | - | - | - |
| F12, F13, G12, G13, H12, H13, J17, J18, K17, K18, K19, L14, L15, M14, M15, R17, R18, R19, T17, T18, T19, T20 | vdd_core | 0 | PWR | - | - | - | - | - | - | - | - |
| F10, G9, G10, H9, H10, J9, J10, L11, L12, M6, M7, M8, M12, N6, N7, N8, R6, R7, R8, T7, T8, U12, U13, V12, V13, W12, W13 | vdd_mpu_iva | 0 | PWR | - | - | - | - | - | - | - | - |
| H8 | vdds_mmc1a | 0 | PWR | - | - | - | - | - | - | - | - |
| M17, M18, M19, N17, N18, N19, U10, V9, V10, W9, W10, Y9 | vdds | 0 | PWR | - | - | - | - | - | - | - | - |
| N24 | vdds_mmc1 | 0 | PWR | - | - | - | - | - | - | - | - |
| Y12, U8, H17 | cap_vdd_wkup, cap_vdd_sram_mpu_iva, cap_vdd_sram_core | 0 | PWR | - | - | - | - | - | - | - | - |
| G18 | vdds_dpll_dll | 0 | PWR | - | - | - | - | - | - | - | - |
| U17 | vdds_dpll_per | 0 | PWR | - | - | - | - | - | - | - | - |
| AA12 | vdds_sram | 0 | PWR | - | - | - | - | - | - | - | - |
| AA13 | vdds_wkup_bg | 0 | PWR | - | - | - | - | - | - | - | - |
| AB15 | vssa_dac | 0 | GND | - | - | - | - | - | - | - | - |
| AB13 | vdda_dac | 0 | PWR | - | - | - | - | - | - | - | - |
| H11, H14, H16, J11, J12, J13, J14, J15, J16, K10, K11, K14, K15, L8, L10, L13, L17, M9, M10, M11, M13, M16, N9, N10, N11, N12, N13, N14, N15, N16, P8, P10, P11, P12, P13, P14, P15, P17, R10, R11, R14, R15, T9, T10, T11, T12, T13, T14, T15, T16, U9, U11, U14, U15, U16, V15, V16, W15 | vss | 0 | GND | - | - | - | - | - | - | - | - |
| AD1, A1, A2, B1 | No Connect | - | - | - | - | - | - | - | - | - | - |

2.4 Multiplexing Characteristics

Table 2-4 provides a description of the OMAP3530/25 multiplexing on the CBB, CBC, and CUS packages, respectively.

Note: The following does not take into account subsystem pin multiplexing options. Subsystem pin multiplexing options are described in Section 2.5, *Signal Description*.

Table 2-4. Multiplexing Characteristics

| CBB | | CBC | | CUS | MODE 0 | MODE 1 | MODE 2 | MODE 3 | MODE 4 | MODE 5 | MODE 6 | MODE 7 |
|--------|------|--------|------|-----|-----------|--------|--------|--------|--------|--------|--------|--------|
| Bottom | Top | Bottom | Top | | | | | | | | | |
| D6 | J2 | NA | D1 | D7 | sdr_c_d0 | | | | | | | |
| C6 | J1 | NA | G1 | C5 | sdr_c_d1 | | | | | | | |
| B6 | G2 | NA | G2 | C6 | sdr_c_d2 | | | | | | | |
| C8 | G1 | NA | E1 | B5 | sdr_c_d3 | | | | | | | |
| C9 | F2 | NA | D2 | D9 | sdr_c_d4 | | | | | | | |
| A7 | F1 | NA | E2 | D10 | sdr_c_d5 | | | | | | | |
| B9 | D2 | NA | B3 | C7 | sdr_c_d6 | | | | | | | |
| A9 | D1 | NA | B4 | B7 | sdr_c_d7 | | | | | | | |
| C14 | B13 | NA | A10 | B11 | sdr_c_d8 | | | | | | | |
| B14 | A13 | NA | B11 | C12 | sdr_c_d9 | | | | | | | |
| C15 | B14 | NA | A11 | B12 | sdr_c_d10 | | | | | | | |
| B16 | A14 | NA | B12 | D13 | sdr_c_d11 | | | | | | | |
| D17 | B16 | NA | A16 | C13 | sdr_c_d12 | | | | | | | |
| C17 | A16 | NA | A17 | B14 | sdr_c_d13 | | | | | | | |
| B17 | B19 | NA | B17 | A14 | sdr_c_d14 | | | | | | | |
| D18 | A19 | NA | B18 | B15 | sdr_c_d15 | | | | | | | |
| D11 | B3 | NA | B7 | C9 | sdr_c_d16 | | | | | | | |
| B10 | A3 | NA | A5 | E12 | sdr_c_d17 | | | | | | | |
| C11 | B5 | NA | B6 | B8 | sdr_c_d18 | | | | | | | |
| D12 | A5 | NA | A6 | B9 | sdr_c_d19 | | | | | | | |
| C12 | B8 | NA | A8 | C10 | sdr_c_d20 | | | | | | | |
| A11 | A8 | NA | B9 | B10 | sdr_c_d21 | | | | | | | |
| B13 | B9 | NA | A9 | D12 | sdr_c_d22 | | | | | | | |
| D14 | A9 | NA | B10 | E13 | sdr_c_d23 | | | | | | | |
| C18 | B21 | NA | C21 | E15 | sdr_c_d24 | | | | | | | |
| A19 | A21 | NA | D20 | D15 | sdr_c_d25 | | | | | | | |
| B19 | D22 | NA | B19 | C15 | sdr_c_d26 | | | | | | | |
| B20 | D23 | NA | C20 | B16 | sdr_c_d27 | | | | | | | |
| D20 | E22 | NA | D21 | C16 | sdr_c_d28 | | | | | | | |
| A21 | E23 | NA | E20 | D16 | sdr_c_d29 | | | | | | | |
| B21 | G22 | NA | E21 | B17 | sdr_c_d30 | | | | | | | |
| C21 | G23 | NA | G21 | B18 | sdr_c_d31 | | | | | | | |
| H9 | AB21 | NA | AA18 | C18 | sdr_c_ba0 | | | | | | | |
| H10 | AC21 | NA | V20 | D18 | sdr_c_ba1 | | | | | | | |
| A4 | N22 | NA | G20 | A4 | sdr_c_a0 | | | | | | | |
| B4 | N23 | NA | K20 | B4 | sdr_c_a1 | | | | | | | |
| B3 | P22 | NA | J20 | D6 | sdr_c_a2 | | | | | | | |
| C5 | P23 | NA | J21 | B3 | sdr_c_a3 | | | | | | | |
| C4 | R22 | NA | U21 | B2 | sdr_c_a4 | | | | | | | |
| D5 | R23 | NA | R20 | C3 | sdr_c_a5 | | | | | | | |
| C3 | T22 | NA | M21 | E3 | sdr_c_a6 | | | | | | | |
| C2 | T23 | NA | M20 | F6 | sdr_c_a7 | | | | | | | |
| C1 | U22 | NA | N20 | E10 | sdr_c_a8 | | | | | | | |
| D4 | U23 | NA | K21 | E9 | sdr_c_a9 | | | | | | | |
| D3 | V22 | NA | Y16 | E7 | sdr_c_a10 | | | | | | | |
| D2 | V23 | NA | N21 | G6 | sdr_c_a11 | | | | | | | |
| D1 | W22 | NA | R21 | G7 | sdr_c_a12 | | | | | | | |

Table 2-4. Multiplexing Characteristics (continued)

| CBB | | CBC | | CUS | MODE 0 | MODE 1 | MODE 2 | MODE 3 | MODE 4 | MODE 5 | MODE 6 | MODE 7 |
|--------|------|--------|------|-----|-----------|------------------|--------------|-------------------|---------|--------|--------|-----------|
| Bottom | Top | Bottom | Top | | | | | | | | | |
| E2 | W23 | NA | AA15 | F7 | sdrc_a13 | | | | | | | |
| E1 | Y22 | NA | Y12 | F9 | sdrc_a14 | | | | | | | |
| H11 | M22 | NA | T21 | A19 | sdrc_ncs0 | | | | | | | |
| H12 | M23 | NA | T20 | B19 | sdrc_ncs1 | | | | | | | |
| A13 | A11 | NA | A12 | A10 | sdrc_clk | | | | | | | |
| A14 | B11 | NA | B13 | A11 | sdrc_nclk | | | | | | | |
| H16 | J22 | NA | Y15 | B20 | sdrc_cke0 | | | | | | | safe_mode |
| H17 | J23 | NA | Y13 | C20 | sdrc_cke1 | | | | | | | safe_mode |
| H14 | L23 | NA | V21 | D19 | sdrc_nras | | | | | | | |
| H13 | L22 | NA | U20 | C19 | sdrc_ncas | | | | | | | |
| H15 | K23 | NA | Y18 | A20 | sdrc_nwe | | | | | | | |
| B7 | C1 | NA | H1 | B6 | sdrc_dm0 | | | | | | | |
| A16 | A17 | NA | A14 | B13 | sdrc_dm1 | | | | | | | |
| B11 | A6 | NA | A4 | A7 | sdrc_dm2 | | | | | | | |
| C20 | A20 | NA | A18 | A16 | sdrc_dm3 | | | | | | | |
| A6 | C2 | NA | C2 | A5 | sdrc_dqs0 | | | | | | | |
| A17 | B17 | NA | B15 | A13 | sdrc_dqs1 | | | | | | | |
| A10 | B6 | NA | B8 | A8 | sdrc_dqs2 | | | | | | | |
| A20 | B20 | NA | A19 | A17 | sdrc_dqs3 | | | | | | | |
| N4 | AC15 | J2 | NA | K4 | gpmc_a1 | | | | gpio_34 | | | safe_mode |
| M4 | AB15 | H1 | NA | K3 | gpmc_a2 | | | | gpio_35 | | | safe_mode |
| L4 | AC16 | H2 | NA | K2 | gpmc_a3 | | | | gpio_36 | | | safe_mode |
| K4 | AB16 | G2 | NA | J4 | gpmc_a4 | | | | gpio_37 | | | safe_mode |
| T3 | AC17 | F1 | NA | J3 | gpmc_a5 | | | | gpio_38 | | | safe_mode |
| R3 | AB17 | F2 | NA | J2 | gpmc_a6 | | | | gpio_39 | | | safe_mode |
| N3 | AC18 | E1 | NA | J1 | gpmc_a7 | | | | gpio_40 | | | safe_mode |
| M3 | AB18 | E2 | NA | H1 | gpmc_a8 | | | | gpio_41 | | | safe_mode |
| L3 | AC19 | D1 | NA | H2 | gpmc_a9 | sys_ndmareq 2 | | | gpio_42 | | | safe_mode |
| K3 | AB19 | D2 | NA | G2 | gpmc_a10 | sys_ndmareq 3 | | | gpio_43 | | | safe_mode |
| K1 | M2 | AA2 | U2 | L2 | gpmc_d0 | | | | | | | |
| L1 | M1 | AA1 | U1 | M1 | gpmc_d1 | | | | | | | |
| L2 | N2 | AC2 | V2 | M2 | gpmc_d2 | | | | | | | |
| P2 | N1 | AC1 | V1 | N2 | gpmc_d3 | | | | | | | |
| T1 | R2 | AE5 | AA3 | M3 | gpmc_d4 | | | | | | | |
| V1 | R1 | AD6 | AA4 | P1 | gpmc_d5 | | | | | | | |
| V2 | T2 | AD5 | Y3 | P2 | gpmc_d6 | | | | | | | |
| W2 | T1 | AC5 | Y4 | R1 | gpmc_d7 | | | | | | | |
| H2 | AB3 | V1 | R1 | R2 | gpmc_d8 | | | | gpio_44 | | | safe_mode |
| K2 | AC3 | Y1 | T1 | T2 | gpmc_d9 | | | | gpio_45 | | | safe_mode |
| P1 | AB4 | T1 | N1 | U1 | gpmc_d10 | | | | gpio_46 | | | safe_mode |
| R1 | AC4 | U2 | P2 | R3 | gpmc_d11 | | | | gpio_47 | | | safe_mode |
| R2 | AB6 | U1 | P1 | T3 | gpmc_d12 | | | | gpio_48 | | | safe_mode |
| T2 | AC6 | P1 | M1 | U2 | gpmc_d13 | | | | gpio_49 | | | safe_mode |
| W1 | AB7 | L2 | J2 | V1 | gpmc_d14 | | | | gpio_50 | | | safe_mode |
| Y1 | AC7 | M2 | K2 | V2 | gpmc_d15 | | | | gpio_51 | | | safe_mode |
| G4 | Y2 | AD8 | AA8 | E2 | gpmc_ncs0 | | | | | | | |
| H3 | Y1 | AD1 | W1 | NA | gpmc_ncs1 | | | | gpio_52 | | | safe_mode |
| V8 | NA | A3 | NA | NA | gpmc_ncs2 | | | | gpio_53 | | | safe_mode |
| U8 | NA | B6 | NA | D2 | gpmc_ncs3 | sys_ndmareq 0 | | | gpio_54 | | | safe_mode |
| T8 | NA | B4 | NA | F4 | gpmc_ncs4 | sys_ndmareq 1 | mcbbsp4_clkx | gpt9_pwm_e vt | gpio_55 | | | safe_mode |
| R8 | NA | C4 | NA | G5 | gpmc_ncs5 | sys_ndmareq 2 | mcbbsp4_dr | gpt10_pwm_ evt | gpio_56 | | | safe_mode |

Table 2-4. Multiplexing Characteristics (continued)

| CBB | | CBC | | CUS | MODE 0 | MODE 1 | MODE 2 | MODE 3 | MODE 4 | MODE 5 | MODE 6 | MODE 7 |
|--------|------|--------|-------------------|------|---------------|--------------|---------------|------------------|---------|----------|--------|-----------|
| Bottom | Top | Bottom | Top | | | | | | | | | |
| P8 | NA | B5 | NA | F3 | gpmc_ncs6 | sys_ndmareq3 | mcbsp4_dx | gpt11_pwm_evt | gpio_57 | | | safe_mode |
| N8 | NA | C5 | NA | G4 | gpmc_ncs7 | gpmc_io_dir | mcbsp4_fsx | gpt8_pwm_evt | gpio_58 | | | safe_mode |
| T4 | W2 | N1 | L1 | W2 | gpmc_clk | | | | gpio_59 | | | safe_mode |
| F3 | W1 | AD10 | AA9 | F1 | gpmc_nadv_ale | | | | | | | |
| G2 | V2 | N2 | L2 | F2 | gpmc_noe | | | | | | | |
| F4 | V1 | M1 | K1 | G3 | gpmc_nwe | | | | | | | |
| G3 | AC12 | K2 | FT ⁽¹⁾ | K5 | gpmc_nbe0_cle | | | | gpio_60 | | | safe_mode |
| U3 | NA | J1 | NA | L1 | gpmc_nbe1 | | | | gpio_61 | | | safe_mode |
| H1 | AB10 | AC6 | Y5 | E1 | gpmc_nwp | | | | gpio_62 | | | safe_mode |
| M8 | AB12 | AC11 | Y10 | C1 | gpmc_wait0 | | | | | | | |
| L8 | AC10 | AC8 | Y8 | NA | gpmc_wait1 | | | | gpio_63 | | | safe_mode |
| K8 | NA | B3 | NA | NA | gpmc_wait2 | | | | gpio_64 | | | safe_mode |
| J8 | NA | C6 | NA | C2 | gpmc_wait3 | sys_ndmareq1 | | | gpio_65 | | | safe_mode |
| D28 | NA | G25 | NA | G22 | dss_pclk | | | | gpio_66 | hw_dbg12 | | safe_mode |
| D26 | NA | K24 | NA | E22 | dss_hsync | | | | gpio_67 | hw_dbg13 | | safe_mode |
| D27 | NA | M25 | NA | F22 | dss_vsync | | | | gpio_68 | | | safe_mode |
| E27 | NA | F26 | NA | J21 | dss_acbias | | | | gpio_69 | | | safe_mode |
| AG22 | NA | AE21 | NA | AC19 | dss_data0 | | uart1_cts | dssvenc656_data0 | gpio_70 | | | safe_mode |
| AH22 | NA | AE22 | NA | AB19 | dss_data1 | | uart1_rts | dssvenc656_data1 | gpio_71 | | | safe_mode |
| AG23 | NA | AE23 | NA | AD20 | dss_data2 | | | dssvenc656_data2 | gpio_72 | | | safe_mode |
| AH23 | NA | AE24 | NA | AC20 | dss_data3 | | | dssvenc656_data3 | gpio_73 | | | safe_mode |
| AG24 | NA | AD23 | NA | AD21 | dss_data4 | | uart3_rx_irrx | dssvenc656_data4 | gpio_74 | | | safe_mode |
| AH24 | NA | AD24 | NA | AC21 | dss_data5 | | uart3_tx_irtx | dssvenc656_data5 | gpio_75 | | | safe_mode |
| E26 | NA | G26 | NA | D24 | dss_data6 | | uart1_tx | dssvenc656_data6 | gpio_76 | hw_dbg14 | | safe_mode |
| F28 | NA | H25 | NA | E23 | dss_data7 | | uart1_rx | dssvenc656_data7 | gpio_77 | hw_dbg15 | | safe_mode |
| F27 | NA | H26 | NA | E24 | dss_data8 | | | | gpio_78 | hw_dbg16 | | safe_mode |
| G26 | NA | J26 | NA | F23 | dss_data9 | | | | gpio_79 | hw_dbg17 | | safe_mode |
| AD28 | NA | AC26 | NA | AC22 | dss_data10 | | | | gpio_80 | | | safe_mode |
| AD27 | NA | AD26 | NA | AC23 | dss_data11 | | | | gpio_81 | | | safe_mode |
| AB28 | NA | AA25 | NA | AB22 | dss_data12 | | | | gpio_82 | | | safe_mode |
| AB27 | NA | Y25 | NA | Y22 | dss_data13 | | | | gpio_83 | | | safe_mode |
| AA28 | NA | AA26 | NA | W22 | dss_data14 | | | | gpio_84 | | | safe_mode |
| AA27 | NA | AB26 | NA | V22 | dss_data15 | | | | gpio_85 | | | safe_mode |
| G25 | NA | L25 | NA | J22 | dss_data16 | | | | gpio_86 | | | safe_mode |
| H27 | NA | L26 | NA | G23 | dss_data17 | | | | gpio_87 | | | safe_mode |
| H26 | NA | M24 | NA | G24 | dss_data18 | | mcspi3_clk | dss_data0 | gpio_88 | | | safe_mode |
| H25 | NA | M26 | NA | H23 | dss_data19 | | mcspi3_simo | dss_data1 | gpio_89 | | | safe_mode |
| E28 | NA | F25 | NA | D23 | dss_data20 | | mcspi3_somi | dss_data2 | gpio_90 | | | safe_mode |
| J26 | NA | N24 | NA | K22 | dss_data21 | | mcspi3_cs0 | dss_data3 | gpio_91 | | | safe_mode |
| AC27 | NA | AC25 | NA | V21 | dss_data22 | | mcspi3_cs1 | dss_data4 | gpio_92 | | | safe_mode |
| AC28 | NA | AB25 | NA | W21 | dss_data23 | | | dss_data5 | gpio_93 | | | safe_mode |
| W28 | NA | V26 | NA | AA23 | tv_out2 | | | | | | | |
| Y28 | NA | W26 | NA | AB24 | tv_out1 | | | | | | | |
| Y27 | NA | W25 | NA | AB23 | tv_vfb1 | | | | | | | |
| W27 | NA | U24 | NA | Y23 | tv_vfb2 | | | | | | | |
| W26 | NA | V23 | NA | Y24 | tv_vref | | | | | | | |

(1) "FT" indicates Feed-Through. For more information, refer to [Section 2.5.10](#).

Table 2-4. Multiplexing Characteristics (continued)

| CBB | | CBC | | CUS | MODE 0 | MODE 1 | MODE 2 | MODE 3 | MODE 4 | MODE 5 | MODE 6 | MODE 7 |
|--------|-----|--------|-----|------|--------------|-------------------|-----------------------|-----------|----------|----------------------|----------|-----------|
| Bottom | Top | Bottom | Top | | | | | | | | | |
| A24 | NA | C23 | NA | A22 | cam_hs | | | | gpio_94 | hw_dbg0 | | safe_mode |
| A23 | NA | D23 | NA | E18 | cam_vs | | | | gpio_95 | hw_dbg1 | | safe_mode |
| C25 | NA | C25 | NA | B22 | cam_xclk | | | | gpio_96 | | | safe_mode |
| C27 | NA | C26 | NA | J19 | cam_pclk | | | | gpio_97 | hw_dbg2 | | safe_mode |
| C23 | NA | B23 | NA | H24 | cam_fld | | cam_global_r reset | | gpio_98 | hw_dbg3 | | safe_mode |
| AG17 | NA | AE16 | NA | AB18 | cam_d0 | | | | gpio_99 | | | safe_mode |
| AH17 | NA | AE15 | NA | AC18 | cam_d1 | | | | gpio_100 | | | safe_mode |
| B24 | NA | A24 | NA | G19 | cam_d2 | | | | gpio_101 | hw_dbg4 | | safe_mode |
| C24 | NA | B24 | NA | F19 | cam_d3 | | | | gpio_102 | hw_dbg5 | | safe_mode |
| D24 | NA | D24 | NA | G20 | cam_d4 | | | | gpio_103 | hw_dbg6 | | safe_mode |
| A25 | NA | C24 | NA | B21 | cam_d5 | | | | gpio_104 | hw_dbg7 | | safe_mode |
| K28 | NA | P25 | NA | L24 | cam_d6 | | | | gpio_105 | | | safe_mode |
| L28 | NA | P26 | NA | K24 | cam_d7 | | | | gpio_106 | | | safe_mode |
| K27 | NA | N25 | NA | J23 | cam_d8 | | | | gpio_107 | | | safe_mode |
| L27 | NA | N26 | NA | K23 | cam_d9 | | | | gpio_108 | | | safe_mode |
| B25 | NA | D25 | NA | F21 | cam_d10 | | | | gpio_109 | hw_dbg8 | | safe_mode |
| C26 | NA | E26 | NA | G21 | cam_d11 | | | | gpio_110 | hw_dbg9 | | safe_mode |
| B26 | NA | E25 | NA | C22 | cam_xclkb | | | | gpio_111 | | | safe_mode |
| B23 | NA | A23 | NA | F18 | cam_wen | | cam_shutter | | gpio_167 | hw_dbg10 | | safe_mode |
| D25 | NA | D26 | NA | J20 | cam_strobe | | | | gpio_126 | hw_dbg11 | | safe_mode |
| AG19 | NA | AD17 | NA | NA | | | | | gpio_112 | | | safe_mode |
| AH19 | NA | AD16 | NA | NA | | | | | gpio_113 | | | safe_mode |
| AG18 | NA | AE18 | NA | NA | | | | | gpio_114 | | | safe_mode |
| AH18 | NA | AE17 | NA | NA | | | | | gpio_115 | | | safe_mode |
| P21 | NA | U18 | NA | V20 | mcbssp2_fsx | | | | gpio_116 | | | safe_mode |
| N21 | NA | R18 | NA | T21 | mcbssp2_clkx | | | | gpio_117 | | | safe_mode |
| R21 | NA | T18 | NA | V19 | mcbssp2_dr | | | | gpio_118 | | | safe_mode |
| M21 | NA | R19 | NA | R20 | mcbssp2_dx | | | | gpio_119 | | | safe_mode |
| N28 | NA | N19 | NA | M23 | mmc1_clk | | | | gpio_120 | | | safe_mode |
| M27 | NA | L18 | NA | L23 | mmc1_cmd | | | | gpio_121 | | | safe_mode |
| N27 | NA | M19 | NA | M22 | mmc1_dat0 | | | | gpio_122 | | | safe_mode |
| N26 | NA | M18 | NA | M21 | mmc1_dat1 | | | | gpio_123 | | | safe_mode |
| N25 | NA | K18 | NA | M20 | mmc1_dat2 | | | | gpio_124 | | | safe_mode |
| P28 | NA | N20 | NA | N23 | mmc1_dat3 | | | | gpio_125 | | | safe_mode |
| P27 | NA | M20 | NA | N22 | mmc1_dat4 | | | | gpio_126 | | | safe_mode |
| P26 | NA | P17 | NA | N21 | mmc1_dat5 | | | | gpio_127 | | | safe_mode |
| R27 | NA | P18 | NA | N20 | mmc1_dat6 | | | | gpio_128 | | | safe_mode |
| R25 | NA | P19 | NA | P24 | mmc1_dat7 | | | | gpio_129 | | | safe_mode |
| AE2 | NA | W10 | NA | Y1 | mmc2_clk | mcspi3_clk | | | gpio_130 | | | safe_mode |
| AG5 | NA | R10 | NA | AB5 | mmc2_cmd | mcspi3_simo | | | gpio_131 | | | safe_mode |
| AH5 | NA | T10 | NA | AB3 | mmc2_dat0 | mcspi3_somi | | | gpio_132 | | | safe_mode |
| AH4 | NA | T9 | NA | Y3 | mmc2_dat1 | | | | gpio_133 | | | safe_mode |
| AG4 | NA | U10 | NA | W3 | mmc2_dat2 | mcspi3_cs1 | | | gpio_134 | | | safe_mode |
| AF4 | NA | U9 | NA | V3 | mmc2_dat3 | mcspi3_cs0 | | | gpio_135 | | | safe_mode |
| AE4 | NA | V10 | NA | AB2 | mmc2_dat4 | mmc2_dir_da t0 | | mmc3_dat0 | gpio_136 | | | safe_mode |
| AH3 | NA | M3 | NA | AA2 | mmc2_dat5 | mmc2_dir_da t1 | cam_global_r reset | mmc3_dat1 | gpio_137 | hsusb3_tll_st p | mm3_rxdp | safe_mode |
| AF3 | NA | L3 | NA | Y2 | mmc2_dat6 | mmc2_dir_c md | cam_shutter | mmc3_dat2 | gpio_138 | hsusb3_tll_di r | | safe_mode |
| AE3 | NA | K3 | NA | AA1 | mmc2_dat7 | mmc2_clkin | | mmc3_dat3 | gpio_139 | hsusb3_tll_n xt | mm3_rxdm | safe_mode |
| AF6 | NA | P3 | NA | V6 | mcbssp3_dx | uart2_cts | | | gpio_140 | hsusb3_tll_d ata4 | | safe_mode |
| AE6 | NA | N3 | NA | V5 | mcbssp3_dr | uart2_rts | | | gpio_141 | hsusb3_tll_d ata5 | | safe_mode |

Table 2-4. Multiplexing Characteristics (continued)

| CBB | | CBC | | CUS | MODE 0 | MODE 1 | MODE 2 | MODE 3 | MODE 4 | MODE 5 | MODE 6 | MODE 7 |
|--------|-----|--------|-----|------|-----------------|--------------|-------------------|------------|----------|-------------------|------------|-----------|
| Bottom | Top | Bottom | Top | | | | | | | | | |
| AF5 | NA | U3 | NA | W4 | mcbasp3_clkx | uart2_tx | | | gpio_142 | hsusb3_tll_d_ata6 | | safe_mode |
| AE5 | NA | W3 | NA | V4 | mcbasp3_fsx | uart2_rx | | | gpio_143 | hsusb3_tll_d_ata7 | | safe_mode |
| AB26 | NA | Y24 | NA | NA | uart2_cts | mcbasp3_dx | gpt9_pwm_evt | | gpio_144 | | | safe_mode |
| AB25 | NA | AA24 | NA | NA | uart2_rts | mcbasp3_dr | gpt10_pwm_evt | | gpio_145 | | | safe_mode |
| AA25 | NA | AD22 | NA | NA | uart2_tx | mcbasp3_clkx | gpt11_pwm_evt | | gpio_146 | | | safe_mode |
| AD25 | NA | AD21 | NA | NA | uart2_rx | mcbasp3_fsx | gpt8_pwm_evt | | gpio_147 | | | safe_mode |
| AA8 | NA | L4 | NA | W7 | uart1_tx | | | | gpio_148 | | | safe_mode |
| AA9 | NA | R2 | NA | W6 | uart1_rts | | | | gpio_149 | | | safe_mode |
| W8 | NA | W2 | NA | AC2 | uart1_cts | | | | gpio_150 | hsusb3_tll_clk | | safe_mode |
| Y8 | NA | H3 | NA | V7 | uart1_rx | | mcbasp1_clkr | mcspi4_clk | gpio_151 | | | safe_mode |
| AE1 | NA | V3 | NA | NA | mcbasp4_clkx | | | | gpio_152 | hsusb3_tll_d_ata1 | mm3_txse0 | safe_mode |
| AD1 | NA | U4 | NA | NA | mcbasp4_dr | | | | gpio_153 | hsusb3_tll_d_ata0 | mm3_rxcv | safe_mode |
| AD2 | NA | R3 | NA | NA | mcbasp4_dx | | | | gpio_154 | hsusb3_tll_d_ata2 | mm3_txdat | safe_mode |
| AC1 | NA | T3 | NA | NA | mcbasp4_fsx | | | | gpio_155 | hsusb3_tll_d_ata3 | mm3_txen_n | safe_mode |
| Y21 | NA | U19 | NA | W19 | mcbasp1_clkr | mcspi4_clk | | | gpio_156 | | | safe_mode |
| AA21 | NA | V17 | NA | AB20 | mcbasp1_fsr | | cam_global_r eset | | gpio_157 | | | safe_mode |
| V21 | NA | U17 | NA | W18 | mcbasp1_dx | mcspi4_simo | mcbasp3_dx | | gpio_158 | | | safe_mode |
| U21 | NA | T20 | NA | Y18 | mcbasp1_dr | mcspi4_somi | mcbasp3_dr | | gpio_159 | | | safe_mode |
| T21 | NA | T19 | NA | AA18 | mcbasp_clks | | cam_shutter | | gpio_160 | uart1_cts | | safe_mode |
| K26 | NA | P20 | NA | AA19 | mcbasp1_fsx | mcspi4_cs0 | mcbasp3_fsx | | gpio_161 | | | safe_mode |
| W21 | NA | T17 | NA | V18 | mcbasp1_clkx | | mcbasp3_clkx | | gpio_162 | | | safe_mode |
| H18 | NA | F23 | NA | A23 | uart3_cts_rct_x | | | | gpio_163 | | | safe_mode |
| H19 | NA | F24 | NA | B23 | uart3_rts_sd | | | | gpio_164 | | | safe_mode |
| H20 | NA | H24 | NA | B24 | uart3_rx_irrx | | | | gpio_165 | | | safe_mode |
| H21 | NA | G24 | NA | C23 | uart3_tx_irrx | | | | gpio_166 | | | safe_mode |
| T28 | NA | W19 | NA | R21 | hsusb0_clk | | | | gpio_120 | | | safe_mode |
| T25 | NA | U20 | NA | R23 | hsusb0_stp | | | | gpio_121 | | | safe_mode |
| R28 | NA | V19 | NA | P23 | hsusb0_dir | | | | gpio_122 | | | safe_mode |
| T26 | NA | W18 | NA | R22 | hsusb0_nxt | | | | gpio_124 | | | safe_mode |
| T27 | NA | V20 | NA | T24 | hsusb0_data_0 | | uart3_tx_irtx | | gpio_125 | | | safe_mode |
| U28 | NA | Y20 | NA | T23 | hsusb0_data_1 | | uart3_rx_irrx | | gpio_130 | | | safe_mode |
| U27 | NA | V18 | NA | U24 | hsusb0_data_2 | | uart3_rts_sd | | gpio_131 | | | safe_mode |
| U26 | NA | W20 | NA | U23 | hsusb0_data_3 | | uart3_cts_rct_x | | gpio_169 | | | safe_mode |
| U25 | NA | W17 | NA | W24 | hsusb0_data_4 | | | | gpio_188 | | | safe_mode |
| V28 | NA | Y18 | NA | V23 | hsusb0_data_5 | | | | gpio_189 | | | safe_mode |
| V27 | NA | Y19 | NA | W23 | hsusb0_data_6 | | | | gpio_190 | | | safe_mode |
| V26 | NA | Y17 | NA | T22 | hsusb0_data_7 | | | | gpio_191 | | | safe_mode |
| K21 | NA | J25 | NA | K20 | i2c1_scl | | | | | | | |
| J21 | NA | J24 | NA | K21 | i2c1_sda | | | | | | | |
| AF15 | NA | C2 | NA | AC15 | i2c2_scl | | | | gpio_168 | | | safe_mode |
| AE15 | NA | C1 | NA | AC14 | i2c2_sda | | | | gpio_183 | | | safe_mode |

Table 2-4. Multiplexing Characteristics (continued)

| CBB | | CBC | | CUS | MODE 0 | MODE 1 | MODE 2 | MODE 3 | MODE 4 | MODE 5 | MODE 6 | MODE 7 |
|--------|-----|--------|-----|------|-------------------|-------------------|----------------------|------------------|----------|------------|--------------------|-----------|
| Bottom | Top | Bottom | Top | | | | | | | | | |
| AF14 | NA | AB4 | NA | AC13 | i2c3_scl | | | | gpio_184 | | | safe_mode |
| AG14 | NA | AC4 | NA | AC12 | i2c3_sda | | | | gpio_185 | | | safe_mode |
| AD26 | NA | AD15 | NA | Y16 | i2c4_scl | sys_nvmode 1 | | | | | | safe_mode |
| AE26 | NA | W16 | NA | Y15 | i2c4_sda | sys_nvmode 2 | | | | | | safe_mode |
| J25 | NA | J23 | NA | A24 | hdq_sio | sys_altclk | i2c2_sccbe | i2c3_sccbe | gpio_170 | | | safe_mode |
| AB3 | NA | P9 | NA | T5 | mcspi1_clk | mmc2_dat4 | | | gpio_171 | | | safe_mode |
| AB4 | NA | P8 | NA | R4 | mcspi1_simo | mmc2_dat5 | | | gpio_172 | | | safe_mode |
| AA4 | NA | P7 | NA | T4 | mcspi1_somi | mmc2_dat6 | | | gpio_173 | | | safe_mode |
| AC2 | NA | R7 | NA | T6 | mcspi1_cs0 | mmc2_dat7 | | | gpio_174 | | | safe_mode |
| AC3 | NA | R8 | NA | NA | mcspi1_cs1 | | | mmc3_cmd | gpio_175 | | | safe_mode |
| AB1 | NA | R9 | NA | NA | mcspi1_cs2 | | | mmc3_clk | gpio_176 | | | safe_mode |
| AB2 | NA | T8 | NA | R5 | mcspi1_cs3 | | hsusb2_tll_d ata2 | hsusb2_data 2 | gpio_177 | mm2_txdat | | safe_mode |
| AA3 | NA | W7 | NA | N5 | mcspi2_clk | | hsusb2_tll_d ata7 | hsusb2_data 7 | gpio_178 | | | safe_mode |
| Y2 | NA | W8 | NA | N4 | mcspi2_simo | gpt9_pwm_e vt | hsusb2_tll_d ata4 | hsusb2_data 4 | gpio_179 | | | safe_mode |
| Y3 | NA | U8 | NA | N3 | mcspi2_somi | gpt10_pwm_e vt | hsusb2_tll_d ata5 | hsusb2_data 5 | gpio_180 | | | safe_mode |
| Y4 | NA | V8 | NA | M5 | mcspi2_cs0 | gpt11_pwm_e vt | hsusb2_tll_d ata6 | hsusb2_data 6 | gpio_181 | | | safe_mode |
| V3 | NA | V9 | NA | M4 | mcspi2_cs1 | gpt8_pwm_e vt | hsusb2_tll_d ata3 | hsusb2_data 3 | gpio_182 | mm2_txen_n | | safe_mode |
| AE25 | NA | AE20 | NA | AA16 | sys_32k | | | | | | | |
| AE17 | NA | AF19 | NA | AD15 | sys_xtalin | | | | | | | |
| AF17 | NA | AF20 | NA | AD14 | sys_xtalout | | | | | | | |
| AF25 | NA | W15 | NA | Y13 | sys_clkreq | | | | gpio_1 | | | safe_mode |
| AF26 | NA | V16 | NA | W16 | sys_nirq | | | | gpio_0 | | | safe_mode |
| AH25 | NA | V13 | NA | AA10 | sys_nrespwr on | | | | | | | |
| AF24 | NA | AD7 | NA | Y10 | sys_nreswar m | | | | gpio_30 | | | safe_mode |
| AH26 | NA | F3 | NA | AB12 | sys_boot0 | | | | gpio_2 | | | safe_mode |
| AG26 | NA | D3 | NA | AC16 | sys_boot1 | | | | gpio_3 | | | safe_mode |
| AE14 | NA | C3 | NA | AD17 | sys_boot2 | | | | gpio_4 | | | safe_mode |
| AF18 | NA | E3 | NA | AD18 | sys_boot3 | | | | gpio_5 | | | safe_mode |
| AF19 | NA | E4 | NA | AC17 | sys_boot4 | mmc2_dir_da t2 | | | gpio_6 | | | safe_mode |
| AE21 | NA | G3 | NA | AB16 | sys_boot5 | mmc2_dir_da t3 | | | gpio_7 | | | safe_mode |
| AF21 | NA | D4 | NA | AA15 | sys_boot6 | | | | gpio_8 | | | safe_mode |
| AF22 | NA | V12 | NA | AD23 | sys_off_mod e | | | | gpio_9 | | | safe_mode |
| AG25 | NA | AE14 | NA | Y7 | sys_clkout1 | | | | gpio_10 | | | safe_mode |
| AE22 | NA | W11 | NA | AA6 | sys_clkout2 | | | | gpio_186 | | | safe_mode |
| AA17 | NA | U15 | NA | AB7 | jtag_ntrst | | | | | | | |
| AA13 | NA | V14 | NA | AB6 | jtag_tck | | | | | | | |
| AA12 | NA | W13 | NA | AA7 | jtag_rtck | | | | | | | |
| AA18 | NA | V15 | NA | AA9 | jtag_tms_tms c | | | | | | | |
| AA20 | NA | U16 | NA | AB10 | jtag_tdi | | | | | | | |
| AA19 | NA | Y13 | NA | AB9 | jtag_tdo | | | | | | | |
| AA11 | NA | Y15 | NA | AC24 | jtag_emu0 | | | | gpio_11 | | | safe_mode |
| AA10 | NA | Y14 | NA | AD24 | jtag_emu1 | | | | gpio_31 | | | safe_mode |
| AF10 | NA | AB2 | NA | AC1 | etk_clk | mcbasp5_clkx | mmc3_clk | hsusb1_stp | gpio_12 | mm1_rxdp | hsusb1_tll_st p | hw_dbg0 |
| AE10 | NA | AB3 | NA | AD3 | etk_ctl | | mmc3_cmd | hsusb1_clk | gpio_13 | | hsusb1_tll_cl k | hw_dbg1 |

Table 2-4. Multiplexing Characteristics (continued)

| CBB | | CBC | | CUS | MODE 0 | MODE 1 | MODE 2 | MODE 3 | MODE 4 | MODE 5 | MODE 6 | MODE 7 |
|---|-----|---|-----|---|---------------|----------------------|-----------|--------------|---------|------------|------------------|----------|
| Bottom | Top | Bottom | Top | | | | | | | | | |
| AF11 | NA | AC3 | NA | AD6 | etk_d0 | mcspi3_simo | mmc3_dat4 | hsusb1_data0 | gpio_14 | mm1_rxcv | hsusb1_tll_data0 | hw_dbg2 |
| AG12 | NA | AD4 | NA | AC6 | etk_d1 | mcspi3_somi | | hsusb1_data1 | gpio_15 | mm1_txse0 | hsusb1_tll_data1 | hw_dbg3 |
| AH12 | NA | AD3 | NA | AC7 | etk_d2 | mcspi3_cs0 | | hsusb1_data2 | gpio_16 | mm1_txdat | hsusb1_tll_data2 | hw_dbg4 |
| AE13 | NA | AA3 | NA | AD8 | etk_d3 | mcspi3_clk | mmc3_dat3 | hsusb1_data7 | gpio_17 | | hsusb1_tll_data7 | hw_dbg5 |
| AE11 | NA | Y3 | NA | AC5 | etk_d4 | mcbsp5_dr | mmc3_dat0 | hsusb1_data4 | gpio_18 | | hsusb1_tll_data4 | hw_dbg6 |
| AH9 | NA | AB1 | NA | AD2 | etk_d5 | mcbsp5_fsx | mmc3_dat1 | hsusb1_data5 | gpio_19 | | hsusb1_tll_data5 | hw_dbg7 |
| AF13 | NA | AE3 | NA | AC8 | etk_d6 | mcbsp5_dx | mmc3_dat2 | hsusb1_data6 | gpio_20 | | hsusb1_tll_data6 | hw_dbg8 |
| AH14 | NA | AD2 | NA | AD9 | etk_d7 | mcspi3_cs1 | mmc3_dat7 | hsusb1_data3 | gpio_21 | mm1_txen_n | hsusb1_tll_data3 | hw_dbg9 |
| AF9 | NA | AA4 | NA | AC4 | etk_d8 | sys_drm_secure | mmc3_dat6 | hsusb1_dir | gpio_22 | | hsusb1_tll_dir | hw_dbg10 |
| AG9 | NA | V2 | NA | AD5 | etk_d9 | sys_secure_indicator | mmc3_dat5 | hsusb1_nxt | gpio_23 | mm1_rxdm | hsusb1_tll_nxt | hw_dbg11 |
| AE7 | NA | AE4 | NA | AC3 | etk_d10 | | uart1_rx | hsusb2_clk | gpio_24 | | hsusb2_tll_clk | hw_dbg12 |
| AF7 | NA | AF6 | NA | AC9 | etk_d11 | | | hsusb2_stp | gpio_25 | mm2_rxdp | hsusb2_tll_stp | hw_dbg13 |
| AG7 | NA | AE6 | NA | AC10 | etk_d12 | | | hsusb2_dir | gpio_26 | | hsusb2_tll_dir | hw_dbg14 |
| AH7 | NA | AF7 | NA | AD11 | etk_d13 | | | hsusb2_nxt | gpio_27 | mm2_rxdm | hsusb2_tll_nxt | hw_dbg15 |
| AG8 | NA | AF9 | NA | AC11 | etk_d14 | | | hsusb2_data0 | gpio_28 | mm2_rxcv | hsusb2_tll_data0 | hw_dbg16 |
| AH8 | NA | AE9 | NA | AD12 | etk_d15 | | | hsusb2_data1 | gpio_29 | mm2_txse0 | hsusb2_tll_data1 | hw_dbg17 |
| AC4, J4, H4, D8, AE9, D9, D15, Y16, AE18, Y18, W18, K18, J18, AE19, Y19, U19, T19, N19, M19, J19, Y20, W20, V20, U20, P20, N20, K20, J20, D22, D23, AE24, M25, L25, E25 | NA | AC21, D15, G11, G18, H20, M7, M17, R20, T7, Y8, Y12 | NA | F12, F13, G12, G13, H12, H13, J17, J18, K17, K18, K19, L14, L15, M14, M15, R17, R18, R19, T17, T18, T19, T20 | vdd_core | | | | | | | |
| Y9, W9, T9, R9, M9, L9, J9, Y10, U10, T10, R10, N10, M10, L10, J10, Y11, W11, K11, J11, W12, K13, Y14, K14, J14, Y15, W15, J15 | NA | D13, G9, G12, H7, K11, L9, M9, M10, N7, N8, P10, U7, U11, U13, V7, V11, W9, Y9, Y11 | NA | F10, G9, G10, H9, H10, J9, J10, L11, L12, M6, M7, M8, M12, N6, N7, N8, R6, R7, R8, T7, T8, U12, U13, V12, V13, W12, W13 | vdd_mpu_iva | | | | | | | |
| AA15 | NA | K14 | NA | Y12 | cap_vdd_wkup | | | | | | | |
| K15 | NA | K13 | NA | G18 | vdds_dpll_dll | | | | | | | |
| W16 | NA | U12 | NA | AA12 | vdds_sram | | | | | | | |

Table 2-4. Multiplexing Characteristics (continued)

| CBB | | CBC | | CUS | MODE 0 | MODE 1 | MODE 2 | MODE 3 | MODE 4 | MODE 5 | MODE 6 | MODE 7 |
|---|-----|---|-----|--|----------------------|--------|--------|--------|--------|--------|--------|--------|
| Bottom | Top | Bottom | Top | | | | | | | | | |
| AD3, AD4, W4, AF8, AE8, AF16, AE16, AF23, AE23, F25, F26, AG27 | NA | A18, AC7, AC15, AC18, AC24, AD20, AE10, C11, D9, E24, G4, J15, J18, L7, L24, M4, T4, T24, W24, Y4, L20, AB24, AD18, AD19 | NA | M17, M18, M19, N17, N18, N19, U10, V9, V10, W9, W10, Y9 | vdds | | | | | | | |
| U1, J1, F1, J2, F2, R4, B5, A5, AH6, B8, A8, B12, A12, D16, C16, B18, A18, B22, A22, G28, C28 | NA | | NA | E16, F15, F16, G15, G16, H15, J6, J7, J8, K6, K7, K8 | vdds_mem | | | | | | | |
| AA16 | NA | U14 | NA | U17 | vdds_dpll_per | | | | | | | |
| AA14 | NA | W14 | NA | AA13 | vdds_wkup_bg | | | | | | | |
| AG2, U2, B2, AG3, W3, P3, J3, E3, A3, P4, E4, AG6, D7, C7, V9, U9, P9, N9, K9, W10, V10, P10, K10, D10, C10, AF12, AE12, Y12, K12, J12, Y13, W13, J13, D13, C13, W14, K16, J16, Y17, W17, K17, J17, W19, V19, R19, P19, L19, K19, D19, C19, AF20, AE20, T20, R2 | NA | A6, A8, A13, AB5, AB22, AC10, AC16, AC19, AD14, AD25, AE7, AF23, B2, B25, C12, D7, D10, D12, D14, D18, D20, E22, G1, G8, G10, G20, G23, H4, K1, K15, K25, L10, L17, L19, L23, N4, N10, N17, R1, R4, R17, T23, U25, W1, W4, W23, Y7, Y10, Y16, Y26 | NA | H11, H14, H16, J11, J12, J13, J14, J15, J16, K10, K11, K14, K15, L8, L10, L13, L17, M9, M10, M11, M13, M16, N9, N10, N11, N12, N13, N14, N15, N16, P8, P10, P11, P12, P13, P14, P15, P17, R10, R11, R14, R15, T9, T10, T11, T12, T13, T14, T15, T16, U9, U11, U14, U15, U16, V15, V16, W15 | vss | | | | | | | |
| V25 | NA | V25 | NA | AB13 | vdda_dac | | | | | | | |
| Y26 | NA | V24 | NA | AB15 | vssa_dac | | | | | | | |
| K25 | NA | N23 | NA | N24 | vdds_mmc1 | | | | | | | |
| P25 | NA | P23 | NA | H8 | vdds_mmc1a | | | | | | | |
| AA26 | NA | Y26 | NA | NA | vss | | | | | | | |
| AE27 | NA | AB24 | NA | NA | vdds | | | | | | | |
| AG21 | NA | AD19 | NA | NA | vdds | | | | | | | |
| AH20 | NA | AE19 | NA | NA | cap_vdd_d | | | | | | | |
| AH21 | NA | AC19 | NA | NA | vss | | | | | | | |
| AG16 | NA | NA | NA | NA | vss | | | | | | | |
| AG20 | NA | NA | NA | NA | vdds | | | | | | | |
| M28 | NA | L19 | NA | NA | vss | | | | | | | |
| H28 | NA | L20 | NA | NA | vdds | | | | | | | |
| V4 | NA | N9 | NA | U8 | cap_vdd_sram_mpu_iva | | | | | | | |
| L21 | NA | K20 | NA | H17 | cap_vdd_sram_core | | | | | | | |

2.5 Signal Description

Many signals are available on multiple pins according to the software configuration of the pin multiplexing options.

1. **SIGNAL NAME:** The signal name
2. **DESCRIPTION:** Description of the signal
3. **TYPE:** Type = Ball type for this specific function:
 - I = Input
 - O = Output
 - Z = High-impedance
 - D = Open Drain
 - DS = Differential
 - A = Analog
4. **BALL BOTTOM:** Associated ball(s) bottom
5. **BALL TOP:** Associated ball(s) top
6. **SUBSYSTEM PIN MULTIPLEXING:** Contains a list of the pin multiplexing options at the module/subsystem level. The pin function is selected at the module/system level.

Note: The Subsystem Multiplexing Signals are not described in the following tables.

2.5.1 External Memory Interfaces

Table 2-5. External Memory Interfaces – GPMC Signals Description

| SIGNAL NAME [1] | DESCRIPTION [2] | TYPE [3] | BALL BOTTOM (CBB Pkg.) [4] | BALL TOP (CBB Pkg.) [5] | BALL BOTTOM (CBC Pkg.) [4] | BALL TOP (CBC Pkg.) [5] | BALL BOTTOM (CUS Pkg.) [4] | SUBSYSTEM PIN MULTIPLEXING [6] |
|-----------------|---------------------------------------|----------|----------------------------|-------------------------|----------------------------|-------------------------|----------------------------|--------------------------------|
| gpmc_a1 | General-purpose memory address bit 1 | O | N4 / K1 | AC15 / M2 | J2 / AA2 | NA / U2 | K4/ L2 | / gpmc_d0 |
| gpmc_a2 | General-purpose memory address bit 2 | O | M4 / L1 | AB15 / M1 | H1 / AA1 | NA / U1 | K3/ M1 | gpmc_a18/ gpmc_d1 |
| gpmc_a3 | General-purpose memory address bit 3 | O | L4 / L2 | AC16 / N2 | H2 / AC2 | NA / V2 | K2/ M2 | gpmc_a19/ gpmc_d2 |
| gpmc_a4 | General-purpose memory address bit 4 | O | K4 / P2 | AB16 / N1 | G2 / AC1 | NA / V1 | J4/ N2 | gpmc_a20/ gpmc_d3 |
| gpmc_a5 | General-purpose memory address bit 5 | O | T3 / T1 | AC17 / R2 | F1 / AE5 | NA / AA3 | J3/ M3 | gpmc_a21/ gpmc_d4 |
| gpmc_a6 | General-purpose memory address bit 6 | O | R3 / V1 | AB17 / R1 | F2 / AD6 | NA / AA4 | J2/ P1 | gpmc_a22/ gpmc_d5 |
| gpmc_a7 | General-purpose memory address bit 7 | O | N3 / V2 | AC18 / T2 | E1 / AD5 | NA / Y3 | J1/ P2 | gpmc_a23/ gpmc_d6 |
| gpmc_a8 | General-purpose memory address bit 8 | O | M3 / W2 | AB18 / T1 | E2 / AC5 | NA / Y4 | H1/ R1 | gpmc_a24/ gpmc_d7 |
| gpmc_a9 | General-purpose memory address bit 9 | O | L3 / H2 | AC19 / AB3 | D1 / V1 | NA / R1 | H2/ R2 | gpmc_a25/ gpmc_d8 |
| gpmc_a10 | General-purpose memory address bit 10 | O | K3 / K2 | AB19 / AC3 | D2 / Y1 | T1 | G2/ T2 | gpmc_a26/ gpmc_d9 |
| gpmc_a11 | General-purpose memory address bit 11 | O | P1 | AB4 | T1 | N1 | U1 | gpmc_d10 |
| gpmc_a12 | General-purpose memory address bit 12 | O | R1 | AC4 | U2 | P2 | R3 | gpmc_d11 |
| gpmc_a13 | General-purpose memory address bit 13 | O | R2 | AB6 | U1 | P1 | T3 | gpmc_d12 |
| gpmc_a14 | General-purpose memory address bit 14 | O | T2 | AC6 | P1 | M1 | U2 | gpmc_d13 |
| gpmc_a15 | General-purpose memory address bit 15 | O | W1 | AB7 | L2 | J2 | V1 | gpmc_d14 |
| gpmc_a16 | General-purpose memory address bit 16 | O | Y1 | AC7 | M2 | K2 | V2 | gpmc_d15 |

Table 2-5. External Memory Interfaces – GPMC Signals Description (continued)

| SIGNAL NAME [1] | DESCRIPTION [2] | TYPE [3] | BALL BOTTOM (CBB Pkg.) [4] | BALL TOP (CBB Pkg.) [5] | BALL BOTTOM (CBC Pkg.) [4] | BALL TOP (CBC Pkg.) [5] | BALL BOTTOM (CUS Pkg.) [4] | SUBSYSTEM PIN MULTIPLEXING [6] |
|-----------------|---------------------------------------|----------|----------------------------|-------------------------|----------------------------|-------------------------|----------------------------|--------------------------------|
| gpmc_a17 | General-purpose memory address bit 17 | O | N4 | AC15 | J2 | NA | K4 | gpmc_a1 |
| gpmc_a18 | General-purpose memory address bit 18 | O | M4 | AB15 | H1 | NA | K3 | gpmc_a2 |
| gpmc_a19 | General-purpose memory address bit 19 | O | L4 | AC16 | H2 | NA | K2 | gpmc_a3 |
| gpmc_a20 | General-purpose memory address bit 20 | O | K4 | AB16 | G2 | NA | J4 | gpmc_a4 |
| gpmc_a21 | General-purpose memory address bit 21 | O | T3 | AC17 | F1 | NA | J3 | gpmc_a5 |
| gpmc_a22 | General-purpose memory address bit 22 | O | R3 | AB17 | F2 | NA | J2 | gpmc_a6 |
| gpmc_a23 | General-purpose memory address bit 23 | O | N3 | AC18 | E1 | NA | J1 | gpmc_a7 |
| gpmc_a24 | General-purpose memory address bit 24 | O | M3 | AB18 | E2 | NA | H1 | gpmc_a8 |
| gpmc_a25 | General-purpose memory address bit 25 | O | L3 | AC19 | D1 | NA | H2 | gpmc_a9 |
| gpmc_a26 | General-purpose memory address bit 26 | O | K3 | AB19 | D2 | NA | G2 | gpmc_a10 |
| gpmc_d0 | GPMC Data bit 0 | IO | K1 | M2 | AA2 | U2 | L2 | gpmc_a1/ gpmc_d0 |
| gpmc_d1 | GPMC Data bit 1 | IO | L1 | M1 | AA1 | U1 | M1 | gpmc_a2/ gpmc_d1 |
| gpmc_d2 | GPMC Data bit 2 | IO | L2 | N2 | AC2 | V2 | M2 | gpmc_a3/ gpmc_d2 |
| gpmc_d3 | GPMC Data bit 3 | IO | P2 | N1 | AC1 | V1 | N2 | gpmc_a4/ gpmc_d3 |
| gpmc_d4 | GPMC Data bit 4 | IO | T1 | R2 | AE5 | AA3 | M3 | gpmc_a5/ gpmc_d4 |
| gpmc_d5 | GPMC Data bit 5 | IO | V1 | R1 | AD6 | AA4 | P1 | gpmc_a6/ gpmc_d5 |
| gpmc_d6 | GPMC Data bit 6 | IO | V2 | T2 | AD5 | Y3 | P2 | gpmc_a7/ gpmc_d6 |
| gpmc_d7 | GPMC Data bit 7 | IO | W2 | T1 | AC5 | Y4 | R1 | gpmc_a8/ gpmc_d7 |
| gpmc_d8 | GPMC Data bit 8 | IO | H2 | AB3 | V1 | R1 | R2 | gpmc_a9/ gpmc_d8 |
| gpmc_d9 | GPMC Data bit 9 | IO | K2 | AC3 | Y1 | T1 | T2 | gpmc_a10/ gpmc_d9 |
| gpmc_d10 | GPMC Data bit 10 | IO | P1 | AB4 | T1 | N1 | U1 | gpmc_a11/ gpmc_d10 |
| gpmc_d11 | GPMC Data bit 11 | IO | R1 | AC4 | U2 | P2 | R3 | gpmc_a12/ gpmc_d11 |
| gpmc_d12 | GPMC Data bit 12 | IO | R2 | AB6 | U1 | P1 | T3 | gpmc_a13/ gpmc_d12 |
| gpmc_d13 | GPMC Data bit 13 | IO | T2 | AC6 | P1 | M1 | U2 | gpmc_a14/ gpmc_d13 |
| gpmc_d14 | GPMC Data bit 14 | IO | W1 | AB7 | L2 | J2 | V1 | gpmc_a15/ gpmc_d14 |
| gpmc_d15 | GPMC Data bit 15 | IO | Y1 | AC7 | M2 | K2 | V2 | gpmc_a16/ gpmc_d15 |
| gpmc_ncs0 | GPMC Chip Select bit 0 | O | G4 | Y2 | AD8 | AA8 | E2 | NA |
| gpmc_ncs1 | GPMC Chip Select bit 1 | O | H3 | Y1 | AD1 | W1 | NA | NA |
| gpmc_ncs2 | GPMC Chip Select bit 2 | O | V8 | NA | A3 | NA | NA | NA |
| gpmc_ncs3 | GPMC Chip Select bit 3 | O | U8 | NA | B6 | NA | D2 | NA |
| gpmc_ncs4 | GPMC Chip Select bit 4 | O | T8 | NA | B4 | NA | F4 | NA |
| gpmc_ncs5 | GPMC Chip Select bit 5 | O | R8 | NA | C4 | NA | G5 | NA |

Table 2-5. External Memory Interfaces – GPMC Signals Description (continued)

| SIGNAL NAME [1] | DESCRIPTION [2] | TYPE [3] | BALL BOTTOM (CBB Pkg.) [4] | BALL TOP (CBB Pkg.) [5] | BALL BOTTOM (CBC Pkg.) [4] | BALL TOP (CBC Pkg.) [5] | BALL BOTTOM (CUS Pkg.) [4] | SUBSYSTEM PIN MULTIPLEXING [6] |
|-----------------|--|----------|----------------------------|-------------------------|----------------------------|-------------------------|----------------------------|--------------------------------|
| gpmc_ncs6 | GPMC Chip Select bit 6 | O | P8 | NA | B5 | NA | F3 | NA |
| gpmc_ncs7 | GPMC Chip Select bit 7 | O | N8 | NA | C5 | NA | G4 | NA |
| gpmc_io_dir | GPMC IO direction control for use with external transceivers | O | N8 | NA | C5 | NA | G4 | NA |
| gpmc_clk | GPMC clock | O | T4 | W2 | N1 | L1 | W2 | NA |
| gpmc_nadv_ale | Address Valid or Address Latch Enable | O | F3 | W1 | AD10 | AA9 | F1 | NA |
| gpmc_noe | Output Enable | O | G2 | V2 | N2 | L2 | F2 | NA |
| gpmc_nwe | Write Enable | O | F4 | V1 | M1 | K1 | G3 | NA |
| gpmc_nbe0_cle | Lower Byte Enable. Also used for Command Latch Enable | O | G3 | AC12 | K2 | FT ⁽¹⁾ | K5 | NA |
| gpmc_nbe1 | Upper Byte Enable | O | U3 | NA | J1 | NA | L1 | NA |
| gpmc_nwp | Flash Write Protect | O | H1 | AB10 | AC6 | Y5 | E1 | NA |
| gpmc_wait0 | External indication of wait | I | M8 | AB12 | AC11 | Y10 | C1 | NA |
| gpmc_wait1 | External indication of wait | I | L8 | AC10 | AC8 | Y8 | NA | NA |
| gpmc_wait2 | External indication of wait | I | K8 | NA | B3 | NA | NA | NA |
| gpmc_wait3 | External indication of wait | I | J8 | NA | C6 | NA | C2 | NA |

(1) FT indicates "Feed-Through. For more information, refer to [Section 2.5.10](#).

Table 2-6. External Memory Interfaces – SDRG Signals Description

| SIGNAL NAME | DESCRIPTION | TYPE ⁽¹⁾ | BALL BOTTOM (CBB Pkg.) | BALL TOP (CBB Pkg.) | BALL BOTTOM (CBC Pkg.) | BALL TOP (CBC Pkg.) | BALL BOTTOM (CUS Pkg.) |
|-------------|-------------------|---------------------|------------------------|---------------------|------------------------|---------------------|------------------------|
| sdrc_d0 | SDRAM data bit 0 | IO | D6 | J2 | NA | D1 | D7 |
| sdrc_d1 | SDRAM data bit 1 | IO | C6 | J1 | NA | G1 | C5 |
| sdrc_d2 | SDRAM data bit 2 | IO | B6 | G2 | NA | G2 | C6 |
| sdrc_d3 | SDRAM data bit 3 | IO | C8 | G1 | NA | E1 | B5 |
| sdrc_d4 | SDRAM data bit 4 | IO | C9 | F2 | NA | D2 | D9 |
| sdrc_d5 | SDRAM data bit 5 | IO | A7 | F1 | NA | E2 | D10 |
| sdrc_d6 | SDRAM data bit 6 | IO | B9 | D2 | NA | B3 | C7 |
| sdrc_d7 | SDRAM data bit 7 | IO | A9 | D1 | NA | B4 | B7 |
| sdrc_d8 | SDRAM data bit 8 | IO | C14 | B13 | NA | A10 | B11 |
| sdrc_d9 | SDRAM data bit 9 | IO | B14 | A13 | NA | B11 | C12 |
| sdrc_d10 | SDRAM data bit 10 | IO | C15 | B14 | NA | A11 | B12 |
| sdrc_d11 | SDRAM data bit 11 | IO | B16 | A14 | NA | B12 | D13 |
| sdrc_d12 | SDRAM data bit 12 | IO | D17 | B16 | NA | A16 | C13 |
| sdrc_d13 | SDRAM data bit 13 | IO | C17 | A16 | NA | A17 | B14 |
| sdrc_d14 | SDRAM data bit 14 | IO | B17 | B19 | NA | B17 | A14 |
| sdrc_d15 | SDRAM data bit 15 | IO | D18 | A19 | NA | B18 | B15 |
| sdrc_d16 | SDRAM data bit 16 | IO | D11 | B3 | NA | B7 | C9 |
| sdrc_d17 | SDRAM data bit 17 | IO | B10 | A3 | NA | A5 | E12 |
| sdrc_d18 | SDRAM data bit 18 | IO | C11 | B5 | NA | B6 | B8 |
| sdrc_d19 | SDRAM data bit 19 | IO | D12 | A5 | NA | A6 | B9 |
| sdrc_d20 | SDRAM data bit 20 | IO | C12 | B8 | NA | A8 | C10 |
| sdrc_d21 | SDRAM data bit 21 | IO | A11 | A8 | NA | B9 | B10 |
| sdrc_d22 | SDRAM data bit 22 | IO | B13 | B9 | NA | A9 | D12 |
| sdrc_d23 | SDRAM data bit 23 | IO | D14 | A9 | NA | B10 | E13 |
| sdrc_d24 | SDRAM data bit 24 | IO | C18 | B21 | NA | C21 | E15 |
| sdrc_d25 | SDRAM data bit 25 | IO | A19 | A21 | NA | D20 | D15 |

(1) Type = Ball type for this specific function (I = Input, O = Output, Z = high-impedance, D = Open Drain, DS = Differential, A = Analog).

Table 2-6. External Memory Interfaces – SDRG Signals Description (continued)

| SIGNAL NAME | DESCRIPTION | TYPE ⁽¹⁾ | BALL BOTTOM (CBB Pkg.) | BALL TOP (CBB Pkg.) | BALL BOTTOM (CBC Pkg.) | BALL TOP (CBC Pkg.) | BALL BOTTOM (CUS Pkg.) |
|-------------|-----------------------------|---------------------|------------------------|---------------------|------------------------|---------------------|------------------------|
| sdrc_d26 | SDRAM data bit 26 | IO | B19 | D22 | NA | B19 | C15 |
| sdrc_d27 | SDRAM data bit 27 | IO | B20 | D23 | NA | C20 | B16 |
| sdrc_d28 | SDRAM data bit 28 | IO | D20 | E22 | NA | D21 | C16 |
| sdrc_d29 | SDRAM data bit 29 | IO | A21 | E23 | NA | E20 | D16 |
| sdrc_d30 | SDRAM data bit 30 | IO | B21 | G22 | NA | E21 | B17 |
| sdrc_d31 | SDRAM data bit 31 | IO | C21 | G23 | NA | G21 | B18 |
| sdrc_ba0 | SDRAM bank select 0 | O | H9 | AB21 | NA | AA18 | C18 |
| sdrc_ba1 | SDRAM bank select 1 | O | H10 | AC21 | NA | V20 | D18 |
| sdrc_a0 | SDRAM address bit 0 | O | A4 | N22 | NA | G20 | A4 |
| sdrc_a1 | SDRAM address bit 1 | O | B4 | N23 | NA | K20 | B4 |
| sdrc_a2 | SDRAM address bit 2 | O | B3 | P22 | NA | J20 | D6 |
| sdrc_a3 | SDRAM address bit 3 | O | C5 | P23 | NA | J21 | B3 |
| sdrc_a4 | SDRAM address bit 4 | O | C4 | R22 | NA | U21 | B2 |
| sdrc_a5 | SDRAM address bit 5 | O | D5 | R23 | NA | R20 | C3 |
| sdrc_a6 | SDRAM address bit 6 | O | C3 | T22 | NA | M21 | E3 |
| sdrc_a7 | SDRAM address bit 7 | O | C2 | T23 | NA | M20 | F6 |
| sdrc_a8 | SDRAM address bit 8 | O | C1 | U22 | NA | N20 | E10 |
| sdrc_a9 | SDRAM address bit 9 | O | D4 | U23 | NA | K21 | E9 |
| sdrc_a10 | SDRAM address bit 10 | O | D3 | V22 | NA | Y16 | E7 |
| sdrc_a11 | SDRAM address bit 11 | O | D2 | V23 | NA | N21 | G6 |
| sdrc_a12 | SDRAM address bit 12 | O | D1 | W22 | NA | R21 | G7 |
| sdrc_a13 | SDRAM address bit 13 | O | E2 | W23 | NA | AA15 | F7 |
| sdrc_a14 | SDRAM address bit 14 | O | E1 | Y22 | NA | Y12 | F9 |
| sdrc_ncs0 | Chip select 0 | O | H11 | M22 | NA | T21 | A19 |
| sdrc_ncs1 | Chip select 1 | O | H12 | M23 | NA | T20 | B19 |
| sdrc_clk | Clock | IO | A13 | A11 | NA | A12 | A10 |
| sdrc_nclk | Clock Invert | O | A14 | B11 | NA | B13 | A11 |
| sdrc_cke0 | Clock Enable 0 | O | H16 | J22 | NA | Y15 | B20 |
| sdrc_cke1 | Clock Enable 1 | O | H17 | J23 | NA | Y13 | C20 |
| sdrc_nras | SDRAM Row Access | O | H14 | L23 | NA | V21 | D19 |
| sdrc_ncas | SDRAM column address strobe | O | H13 | L22 | NA | U20 | C19 |
| sdrc_nwe | SDRAM write enable | O | H15 | K23 | NA | Y18 | A20 |
| sdrc_dm0 | Data Mask 0 | O | B7 | C1 | NA | H1 | B6 |
| sdrc_dm1 | Data Mask 1 | O | A16 | A17 | NA | A14 | B13 |
| sdrc_dm2 | Data Mask 2 | O | B11 | A6 | NA | A4 | A7 |
| sdrc_dm3 | Data Mask 3 | O | C20 | A20 | NA | A18 | A16 |
| sdrc_dqs0 | Data Strobe 0 | IO | A6 | C2 | NA | C2 | A5 |
| sdrc_dqs1 | Data Strobe 1 | IO | A17 | B17 | NA | B15 | A13 |
| sdrc_dqs2 | Data Strobe 2 | IO | A10 | B6 | NA | B8 | A8 |
| sdrc_dqs3 | Data Strobe 3 | IO | A20 | B20 | NA | A19 | A17 |

2.5.2 Video Interfaces

Table 2-7. Video Interfaces – CAM Signals Description

| SIGNAL NAME | DESCRIPTION | TYPE ⁽¹⁾ | BALL BOTTOM (CBB Pkg.) | BALL BOTTOM (CBC Pkg.) | BALL BOTTOM (CUS Pkg.) |
|------------------|---|---------------------|------------------------|------------------------|------------------------|
| cam_hs | Camera Horizontal Synchronization | IO | A24 | C23 | A22 |
| cam_vs | Camera Vertical Synchronization | IO | A23 | D23 | E18 |
| cam_xclka | Camera Clock Output a | O | C25 | C25 | B22 |
| cam_xclkb | Camera Clock Output b | O | B26 | E25 | C22 |
| cam_d0 | Camera digital image data bit 0 | I | AG17 | AE16 | AB18 |
| cam_d1 | Camera digital image data bit 1 | I | AH17 | AE15 | AC18 |
| cam_d2 | Camera digital image data bit 2 | I | B24 | A24 | G19 |
| cam_d3 | Camera digital image data bit 3 | I | C24 | B24 | F19 |
| cam_d4 | Camera digital image data bit 4 | I | D24 | D24 | G20 |
| cam_d5 | Camera digital image data bit 5 | I | A25 | C24 | B21 |
| cam_d6 | Camera digital image data bit 6 | I | K28 | P25 | L24 |
| cam_d7 | Camera digital image data bit 7 | I | L28 | P26 | K24 |
| cam_d8 | Camera digital image data bit 8 | I | K27 | N25 | J23 |
| cam_d9 | Camera digital image data bit 9 | I | L27 | N26 | K23 |
| cam_d10 | Camera digital image data bit 10 | I | B25 | D25 | F21 |
| cam_d11 | Camera digital image data bit 11 | I | C26 | E26 | G21 |
| cam_fld | Camera field identification | IO | C23 | B23 | H24 |
| cam_pclk | Camera pixel clock | I | C27 | C26 | J19 |
| cam_wen | Camera Write Enable | I | B23 | A23 | F18 |
| cam_strobe | Flash strobe control signal | O | D25 | D26 | J20 |
| cam_global_reset | Global reset is used strobe synchronization | IO | C23 / AH3 / AA21 | B23/M3/V17 | H24/ AA2/ AB20 |
| cam_shutter | Mechanical shutter control signal | O | B23 / AF3 / T21 | A23 / T19 | F18/ Y2/ AA18 |

(1) Type = Ball type for this specific function (I = Input, O = Output, Z = high-impedance, D = Open Drain, DS = Differential, A = Analog).

Table 2-8. Video Interfaces – DSS Signals Description

| SIGNAL NAME | DESCRIPTION | TYPE ⁽¹⁾ | BALL BOTTOM (CBB Pkg.) | BALL BOTTOM (CBC Pkg.) | BALL BOTTOM (CUS Pkg.) |
|-------------|---|---------------------|------------------------|------------------------|------------------------|
| dss_pclk | LCD Pixel Clock | O | D28 | G25 | G22 |
| dss_hsync | LCD Horizontal Synchronization | O | D26 | K24 | E22 |
| dss_vsync | LCD Vertical Synchronization | O | D27 | M25 | F22 |
| dss_acbias | AC bias control (STN) or pixel data enable (TFT) output | O | E27 | F26 | J21 |
| dss_data0 | LCD Pixel Data bit 0 | IO | AG22 / H26 | AE21 / M24 | AC19/G24 |
| dss_data1 | LCD Pixel Data bit 1 | IO | AH22 / H25 | AE22 / M26 | AB19/H23 |
| dss_data2 | LCD Pixel Data bit 2 | IO | AG23 / E28 | AE23 / F25 | AD20/D23 |
| dss_data3 | LCD Pixel Data bit 3 | IO | AH23 / J26 | AE24 / N24 | AC20/K22 |
| dss_data4 | LCD Pixel Data bit 4 | IO | AG24 / AC27 | AD23 / AC25 | AD21/V21 |
| dss_data5 | LCD Pixel Data bit 5 | IO | AH24 / AC28 | AD24/ AB25 | AC21/W21 |
| dss_data6 | LCD Pixel Data bit 6 | IO | E26 | G26 | D24 |
| dss_data7 | LCD Pixel Data bit 7 | IO | F28 | H25 | E23 |
| dss_data8 | LCD Pixel Data bit 8 | IO | F27 | H26 | E24 |
| dss_data9 | LCD Pixel Data bit 9 | IO | G26 | J26 | F23 |
| dss_data10 | LCD Pixel Data bit 10 | IO | AD28 | AC26 | AC22 |
| dss_data11 | LCD Pixel Data bit 11 | IO | AD27 | AD26 | AC23 |
| dss_data12 | LCD Pixel Data bit 12 | IO | AB28 | AA25 | AB22 |
| dss_data13 | LCD Pixel Data bit 13 | IO | AB27 | Y25 | Y22 |
| dss_data14 | LCD Pixel Data bit 14 | IO | AA28 | AA26 | W22 |

(1) Type = Ball type for this specific function (I = Input, O = Output, Z = high-impedance, D = Open Drain, DS = Differential, A = Analog).

Table 2-8. Video Interfaces – DSS Signals Description (continued)

| SIGNAL NAME | DESCRIPTION | TYPE ⁽¹⁾ | BALL BOTTOM (CBB Pkg.) | BALL BOTTOM (CBC Pkg.) | BALL BOTTOM (CUS Pkg.) |
|-------------|-----------------------|---------------------|---------------------------|---------------------------|---------------------------|
| dss_data15 | LCD Pixel Data bit 15 | IO | AA27 | AB26 | V22 |
| dss_data16 | LCD Pixel Data bit 16 | IO | G25 | L25 | J22 |
| dss_data17 | LCD Pixel Data bit 17 | IO | H27 | L26 | G23 |
| dss_data18 | LCD Pixel Data bit 18 | IO | H26 | M24 | G24 |
| dss_data19 | LCD Pixel Data bit 19 | IO | H25 | M26 | H23 |
| dss_data20 | LCD Pixel Data bit 20 | O | E28 | F25 | D23 |
| dss_data21 | LCD Pixel Data bit 21 | O | J26 | N24 | K22 |
| dss_data22 | LCD Pixel Data bit 22 | O | AC27 | AC25 | V21 |
| dss_data23 | LCD Pixel Data bit 23 | O | AC28 | AB25 | W21 |

Table 2-9. Video Interfaces – RFBI Signals Description

| SIGNAL NAME | DESCRIPTION | TYPE ⁽¹⁾ | BALL BOTTOM (CBB Pkg.) | BALL BOTTOM (CBC Pkg.) | BALL BOTTOM (CUS Pkg.) | SUBSYSTEM PIN MULTIPLEXING ⁽²⁾ |
|----------------|---|---------------------|---------------------------|---------------------------|---------------------------|--|
| rffi_a0 | RFBI command/data control | O | E27 | F26 | J21 | dss_acbias |
| rffi_cs0 | 1st LCD chip select | O | D26 | K24 | E22 | dss_hsync |
| rffi_da0 | RFBI data bus 0 | IO | AG22 | AE21 | AC19 | dss_data0 |
| rffi_da1 | RFBI data bus 1 | IO | AH22 | AE22 | AB19 | dss_data1 |
| rffi_da2 | RFBI data bus 2 | IO | AG23 | AE23 | AD20 | dss_data2 |
| rffi_da3 | RFBI data bus 3 | IO | AH23 | AE24 | AC20 | dss_data3 |
| rffi_da4 | RFBI data bus 4 | IO | AG24 | AD23 | AD21 | dss_data4 |
| rffi_da5 | RFBI data bus 5 | IO | AH24 | AD24 | AC21 | dss_data5 |
| rffi_da6 | RFBI data bus 6 | IO | E26 | G26 | D24 | dss_data6 |
| rffi_da7 | RFBI data bus 7 | IO | F28 | H25 | E23 | dss_data7 |
| rffi_da8 | RFBI data bus 8 | IO | F27 | H26 | E24 | dss_data8 |
| rffi_da9 | RFBI data bus 9 | IO | G26 | J26 | F23 | dss_data9 |
| rffi_da10 | RFBI data bus 10 | IO | AD28 | AC26 | AC22 | dss_data10 |
| rffi_da11 | RFBI data bus 11 | IO | AD27 | AD26 | AC23 | dss_data11 |
| rffi_da12 | RFBI data bus 12 | IO | AB28 | AA25 | AB22 | dss_data12 |
| rffi_da13 | RFBI data bus 13 | IO | AB27 | Y25 | Y22 | dss_data13 |
| rffi_da14 | RFBI data bus 14 | IO | AA28 | AA26 | W22 | dss_data14 |
| rffi_da15 | RFBI data bus 15 | IO | AA27 | AB26 | V22 | dss_data15 |
| rffi_rd | Read enable for RFBI | O | D28 | G25 | G22 | dss_pclk |
| rffi_wr | Write Enable for RFBI | O | D27 | M25 | F22 | dss_vsync |
| rffi_te_vsync0 | tearing effect removal and Vsync input from 1st LCD | I | G25 | L25 | J22 | dss_data16 |
| rffi_hsync0 | Hsync for 1st LCD | I | H27 | L26 | G23 | dss_data17 |
| rffi_te_vsync1 | tearing effect removal and Vsync input from 2nd LCD | I | H26 | M24 | G24 | dss_data18 |
| rffi_hsync1 | Hsync for 2nd LCD | I | H25 | M26 | H23 | dss_data19 |
| rffi_cs1 | 2nd LCD chip select | O | E28 | F25 | D23 | dss_data20 |

(1) Type = Ball type for this specific function (I = Input, O = Output, Z = high-impedance, D = Open Drain, DS = Differential, A = Analog).

(2) The subsystem pin multiplexing options are not described in and

Table 2-10. Video Interfaces – TV Signals Description

| SIGNAL NAME | DESCRIPTION | TYPE ⁽¹⁾ | BALL BOTTOM (CBB Pkg.) | BALL BOTTOM (CBC Pkg.) | BALL BOTTOM (CUS Pkg.) |
|-------------|--|---------------------|---------------------------|---------------------------|---------------------------|
| tv_out1 | TV analog output Composite: tv_out1 | O | Y28 | W26 | AB24 |
| tv_out2 | TV analog output S-VIDEO: tv_out2 | O | W28 | V26 | AA23 |
| tv_vfb1 | tv_vfb1: Feedback through external resistor to composite | AO | Y27 | W25 | AB23 |
| tv_vfb2 | tv_vfb2: Feedback through external resistor to S-VIDEO | AO | W27 | U24 | Y23 |
| tv_vref | External capacitor | AO | W26 | V23 | Y24 |

(1) Type = Ball type for this specific function (I = Input, O = Output, Z = high-impedance, D = Open Drain, DS = Differential, A = Analog).

2.5.3 Serial Communication Interfaces

Table 2-11. Serial Communication Interfaces – HDQ/1-Wire Signals Description

| SIGNAL NAME | DESCRIPTION | TYPE ⁽¹⁾ | BALL BOTTOM (CBB Pkg.) | BALL BOTTOM (CBC Pkg.) | BALL BOTTOM (CUS Pkg.) |
|-------------|--|---------------------|------------------------|------------------------|------------------------|
| hdq_sio | Bidirectional HDQ 1-Wire control and data Interface. Output is open drain. | IOD | J25 | J23 | A24 |

(1) Type = Ball type for this specific function (I = Input, O = Output, Z = high-impedance, D = Open Drain, DS = Differential, A = Analog).

Table 2-12. Serial Communication Interfaces – I²C Signals Description

| SIGNAL NAME | DESCRIPTION | TYPE ⁽¹⁾ | BALL BOTTOM (CBB Pkg.) | BALL BOTTOM (CBC Pkg.) | BALL BOTTOM (CUS Pkg.) |
|--|---|---------------------|------------------------|------------------------|------------------------|
| INTER-INTEGRATED CIRCUIT INTERFACE (I2C1) | | | | | |
| i2c1_scl | I ² C Master Serial clock. Output is open drain. | IOD | K21 | J25 | K20 |
| i2c1_sda | I ² C Serial Bidirectional Data. Output is open drain. | IOD | J21 | J24 | K21 |
| INTER-INTEGRATED CIRCUIT INTERFACE (I2C3) | | | | | |
| i2c3_scl | I ² C Master Serial clock. Output is open drain. | IOD | AF14 | AB4 | AC13 |
| i2c3_sda | I ² C Serial Bidirectional Data. Output is open drain. | IOD | AG14 | AC4 | AC12 |
| i2c3_sccbe | Serial Camera Control Bus Enable | O | J25 | J23 | A24 |
| INTER-INTEGRATED CIRCUIT INTERFACE (I2C2) | | | | | |
| i2c2_scl | I ² C Master Serial clock. Output is open drain. | IOD | AF15 | C2 | AC15 |
| i2c2_sda | I ² C Serial Bidirectional Data. Output is open drain. | IOD | AE15 | C1 | AC14 |
| i2c2_sccbe | Serial Camera Control Bus Enable | O | J25 | J23 | A24 |

(1) Type = Ball type for this specific function (I = Input, O = Output, Z = high-impedance, D = Open Drain, DS = Differential, A = Analog).

Table 2-13. Serial Communication Interfaces – SmartReflex Signals Description⁽¹⁾

| SIGNAL NAME | DESCRIPTION | TYPE ⁽²⁾ | BALL BOTTOM (CBB Pkg.) | BALL BOTTOM (CBC Pkg.) | BALL BOTTOM (CUS Pkg.) |
|--|---|---------------------|------------------------|------------------------|------------------------|
| INTER-INTEGRATED CIRCUIT INTERFACE (I2C4) | | | | | |
| i2c4_scl | I ² C Master Serial clock. Output is open drain. | IOD | AD26 | AD15 | Y16 |
| i2c4_sda | I ² C Serial Bidirectional Data. Output is open drain. | IOD | AE26 | W16 | Y15 |

(1) For more information on SmartReflex voltage control, see the PRCM chapter of the *OMAP35x Technical Reference Manual (TRM)* [literature number [SPRUFA5](#)].

(2) Type = Ball type for this specific function (I = Input, O = Output, Z = high-impedance, D = Open Drain, DS = Differential, A = Analog).

Table 2-14. Serial Communication Interfaces – McBSP LP Signals Description

| SIGNAL NAME | DESCRIPTION | TYPE ⁽¹⁾ | BALL BOTTOM (CBB Pkg.) | BALL BOTTOM (CBC Pkg.) | BALL BOTTOM (CUS Pkg.) |
|---|---|---------------------|------------------------|------------------------|------------------------|
| MULTICHANNEL SERIAL (McBSP LP 1) | | | | | |
| mcbasp1_dr | Received serial data | I | U21 | T20 | Y18 |
| mcbasp1_clkr | Receive Clock | IO | Y8 / Y21 | U19 / H3 | V7 / W19 |
| mcbasp1_fsr | Receive frame synchronization | IO | AA21 | V17 | AB20 |
| mcbasp1_dx | Transmitted serial data | IO | V21 | U17 | W18 |
| mcbasp1_clkx | Transmit clock | IO | W21 | T17 | V18 |
| mcbasp1_fsx | Transmit frame synchronization | IO | K26 | P20 | AA19 |
| mcbasp_clks | External clock input (shared by McBSP1, 2, 3, 4, and 5) | I | T21 | T19 | AA18 |

(1) Type = Ball type for this specific function (I = Input, O = Output, Z = high-impedance, D = Open Drain, DS = Differential, A = Analog)

Table 2-14. Serial Communication Interfaces – McBSP LP Signals Description (continued)

| SIGNAL NAME | DESCRIPTION | TYPE ⁽¹⁾ | BALL BOTTOM (CBB Pkg.) | BALL BOTTOM (CBC Pkg.) | BALL BOTTOM (CUS Pkg.) |
|---|--------------------------------|---------------------|------------------------|------------------------|------------------------|
| MULTICHANNEL SERIAL (McBSP LP 2) | | | | | |
| mcbsp2_dr | Received serial data | I | R21 | T18 | V19 |
| mcbsp2_dx | Transmitted serial data | IO | M21 | R19 | R20 |
| mcbsp2_clkx | Combined serial clock | IO | N21 | R18 | T21 |
| mcbsp2_fsx | Combined frame synchronization | IO | P21 | U18 | V20 |
| MULTICHANNEL SERIAL (McBSP LP 3) | | | | | |
| mcbsp3_dr | Received serial data | I | AE6 / AB25 / U21 | T20 / AA24 / N3 | V5 / Y18 |
| mcbsp3_dx | Transmitted serial data | IO | AF6 / AB26 / V21 | U17 / Y24 / P3 | V6 / W18 |
| mcbsp3_clkx | Combined serial clock | IO | AF5 / AA25 / W21 | T17 / AD22 / U3 | W4 / V18 |
| mcbsp3_fsx | Combined frame synchronization | IO | AE5 / AD25 / K26 | P20 / AD21 / W3 | V4 / AA19 |
| MULTICHANNEL SERIAL (McBSP LP 4) | | | | | |
| mcbsp4_dr | Received serial data | I | R8 / AD1 | C4 / U4 | G5 |
| mcbsp4_dx | Transmitted serial data | IO | P8 / AD2 | B5 / R3 | F3 |
| mcbsp4_clkx | Combined serial clock | IO | T8 / AE1 | B4 / V3 | F4 |
| mcbsp4_fsx | Combined frame synchronization | IO | N8 / AC1 | C5 / T3 | G4 |
| MULTICHANNEL SERIAL (McBSP LP 5) | | | | | |
| mcbsp5_dr | Received serial data | I | AE11 | Y3 | AC5 |
| mcbsp5_dx | Transmitted serial data | IO | AF13 | AE3 | AC8 |
| mcbsp5_clkx | Combined serial clock | IO | AF10 | AB2 | AC1 |
| mcbsp5_fsx | Combined frame synchronization | IO | AH9 | AB1 | AD2 |

Table 2-15. Serial Communication Interfaces – McSPI Signals Description

| SIGNAL NAME | DESCRIPTION | TYPE ⁽¹⁾ | BALL BOTTOM (CBB Pkg.) | BALL BOTTOM (CBC Pkg.) | BALL BOTTOM (CUS Pkg.) |
|--|---|---------------------|------------------------|------------------------|------------------------|
| MULTICHANNEL SERIAL PORT INTERFACE (McSPI1) | | | | | |
| mcspi1_clk | SPI Clock | IO | AB3 | P9 | T5 |
| mcspi1_simo | Slave data in, master data out | IO | AB4 | P8 | R4 |
| mcspi1_somi | Slave data out, master data in | IO | AA4 | P7 | T4 |
| mcspi1_cs0 | SPI Enable 0, polarity configured by software | IO | AC2 | R7 | T6 |
| mcspi1_cs1 | SPI Enable 1, polarity configured by software | O | AC3 | R8 | NA |
| mcspi1_cs2 | SPI Enable 2, polarity configured by software | O | AB1 | R9 | NA |
| mcspi1_cs3 | SPI Enable 3, polarity configured by software | O | AB2 | T8 | R5 |
| MULTICHANNEL SERIAL PORT INTERFACE (McSPI2) | | | | | |
| mcspi2_clk | SPI Clock | IO | AA3 | W7 | N5 |
| mcspi2_simo | Slave data in, master data out | IO | Y2 | W8 | N4 |
| mcspi2_somi | Slave data out, master data in | IO | Y3 | U8 | N3 |
| mcspi2_cs0 | SPI Enable 0, polarity configured by software | IO | Y4 | V8 | M5 |
| mcspi2_cs1 | SPI Enable 1, polarity configured by software | O | V3 | V9 | M4 |
| MULTICHANNEL SERIAL PORT INTERFACE (McSPI3) | | | | | |
| mcspi3_clk | SPI Clock | IO | H26 / AE2 / AE13 | W10 / M24 / AA3 | G24 / Y1 / AD8 |
| mcspi3_simo | Slave data in, master data out | IO | H25 / AG5 / AF11 | R10 / M26 / AC3 | H23 / AB5 / AD6 |
| mcspi3_somi | Slave data out, master data in | IO | E28 / AH5 / AG12 | F25 / T10 / AD4 | D23 / AB3 / AC6 |
| mcspi3_cs0 | SPI Enable 0, polarity configured by software | IO | J26 / AF4 / AH12 | U9 / N24 / AD3 | K22 / V3 / AC7 |
| mcspi3_cs1 | SPI Enable 1, polarity configured by software | O | AC27 / AG4 / AH14 | AC25 / U10 / AD2 | V21 / W3 / AD9 |

(1) Type = Ball type for this specific function (I = Input, O = Output, Z = high-impedance, D = Open Drain, DS = Differential, A = Analog)

Table 2-15. Serial Communication Interfaces – McSPI Signals Description (continued)

| SIGNAL NAME | DESCRIPTION | TYPE ⁽¹⁾ | BALL BOTTOM (CBB Pkg.) | BALL BOTTOM (CBC Pkg.) | BALL BOTTOM (CUS Pkg.) |
|--|---|---------------------|---------------------------|---------------------------|---------------------------|
| MULTICHANNEL SERIAL PORT INTERFACE (McSPI4) | | | | | |
| mcspi4_clk | SPI Clock | IO | Y8 / Y21 | U19 / H3 | V7 / W19 |
| mcspi4_simo | Slave data in, master data out | IO | V21 | U17 | W18 |
| mcspi4_somi | Slave data out, master data in | IO | U21 | T20 | Y18 |
| mcspi4_cs0 | SPI Enable 0, polarity configured by software | IO | K26 | P20 | AA19 |

Table 2-16. Serial Communication Interfaces – UARTs Signals Description

| SIGNAL NAME | DESCRIPTION | TYPE ⁽¹⁾ | BALL BOTTOM (CBB Pkg.) | BALL BOTTOM (CBC Pkg.) | BALL BOTTOM (CUS Pkg.) |
|---|---|---------------------|---------------------------|---------------------------|---------------------------|
| UNIVERSAL ASYNCHRONOUS RECEIVER/TRANSMITTER (UART1) | | | | | |
| uart1_cts | UART1 Clear To Send | I | AG22 / W8 / T21 | AE21 / T19 / W2 | AC19 / AC2 / AA18 |
| uart1_rts | UART1 Request To Send | O | AH22 / AA9 | AE22 / R2 | W6 / AB19 |
| uart1_rx | UART1 Receive data | I | F28 / Y8 / AE7 | H3 / H25 / AE4 | E23 / V7 / AC3 |
| uart1_tx | UART1 Transmit data | O | E26 / AA8 | L4 / G26 | D24 / W7 |
| UNIVERSAL ASYNCHRONOUS RECEIVER/TRANSMITTER (UART2) | | | | | |
| uart2_cts | UART2 Clear To Send | I | AF6 / AB26 | N23/Y24 | V6 |
| uart2_rts | UART2 Request To Send | O | AE6 / AB25 | P3/AA24 | V5 |
| uart2_rx | UART2 Receive data | I | AE5 / AD25 | W3/AD21 | V4 |
| uart2_tx | UART2 Transmit data | O | AF5 / AA25 | V3/AD22 | W4 |
| UNIVERSAL ASYNCHRONOUS RECEIVER/TRANSMITTER (UART3) / IrDA | | | | | |
| uart3_cts_rctx | UART3 Clear To Send (input), Remote TX (output) | IO | H18 / U26 | W20 / F23 | A23 / U23 |
| uart3_rts_sd | UART3 Request To Send, IR enable | O | H19 / U27 | V18 / F24 | B23 / U24 |
| uart3_rx_irrx | UART3 Receive data, IR and Remote RX | I | AG24 / H20 / U28 | AD23 / Y20 / H24 | AD21 / B24 / T23 |
| uart3_tx_irtx | UART3 Transmit data, IR TX | O | AH24 / H21 / T27 | AD24 / V20 / G24 | AC21 / C23 / T24 |

(1) Type = Ball type for this specific function (I = Input, O = Output, Z = high-impedance, D = Open Drain, DS = Differential, A = Analog)

Table 2-17. Serial Communication Interfaces – USB Signals Description

| SIGNAL NAME | DESCRIPTION | TYPE ⁽¹⁾ | BALL BOTTOM (CBB Pkg.) | BALL BOTTOM (CBC Pkg.) | BALL BOTTOM (CUS Pkg.) |
|---|--|---------------------|---------------------------|---------------------------|---------------------------|
| HIGH-SPEED UNIVERSAL SERIAL BUS INTERFACE (HSUSB0) | | | | | |
| hsusb0_clk | Dedicated for external transceiver 60-MHz clock input to PHY | O | T28 | W19 | R21 |
| hsusb0_stp | Dedicated for external transceiver Stop signal | O | T25 | U20 | R23 |
| hsusb0_dir | Dedicated for external transceiver Data direction control from PHY | I | R28 | V19 | P23 |
| hsusb0_nxt | Dedicated for external transceiver Next signal from PHY | I | T26 | W18 | R22 |
| hsusb0_data0 | Dedicated for external transceiver Bidirectional data bus | IO | T27 | V20 | T24 |
| hsusb0_data1 | Dedicated for external transceiver Bidirectional data bus | IO | U28 | Y20 | T23 |
| hsusb0_data2 | Dedicated for external transceiver Bidirectional data bus | IO | U27 | V18 | U24 |
| hsusb0_data3 | Dedicated for external transceiver Bidirectional data bus | IO | U26 | W20 | U23 |
| hsusb0_data4 | Dedicated for external transceiver Bidirectional data bus additional signals for 12-pin ULPI operation | IO | U25 | W17 | W24 |
| hsusb0_data5 | Dedicated for external transceiver Bidirectional data bus additional signals for 12-pin ULPI operation | IO | V28 | Y18 | V23 |
| hsusb0_data6 | Dedicated for external transceiver Bidirectional data bus additional signals for 12-pin ULPI operation | IO | V27 | Y19 | W23 |
| hsusb0_data7 | Dedicated for external transceiver Bidirectional data bus additional signals for 12-pin ULPI operation | IO | V26 | Y17 | T22 |
| MM_FSUSB3 | | | | | |

(1) Type = Ball type for this specific function (I = Input, O = Output, Z = high-impedance, D = Open Drain, DS = Differential, A = Analog)

Table 2-17. Serial Communication Interfaces – USB Signals Description (continued)

| SIGNAL NAME | DESCRIPTION | TYPE ⁽¹⁾ | BALL BOTTOM (CBB Pkg.) | BALL BOTTOM (CBC Pkg.) | BALL BOTTOM (CUS Pkg.) |
|-------------------|--|---------------------|------------------------|------------------------|------------------------|
| mm3_rxdm | Vminus receive data (not used in 3- or 4-pin configurations) | IO | AE3 | K3 | NA ⁽²⁾ |
| mm3_rxdp | Vplus receive data (not used in 3- or 4-pin configurations) | IO | AH3 | M3 | NA ⁽²⁾ |
| mm3_rxcv | Differential receiver signal input (not used in 3-pin mode) | IO | AD1 | U4 | NA |
| mm3_txse0 | Single-ended zero. Used as VM in 4-pin VP_VM mode. | IO | AE1 | V3 | NA |
| mm3_txdat | USB data. Used as VP in 4-pin VP_VM mode. | IO | AD2 | R3 | NA |
| mm3_txen_n | Transmit enable | IO | AC1 | T3 | NA |
| MM_FSUSB2 | | | | | |
| mm2_rxdm | Vminus receive data (not used in 3- or 4-pin configurations) | IO | AH7 | AF7 | AD11 |
| mm2_rxdp | Vplus receive data (not used in 3- or 4-pin configurations) | IO | AF7 | AF6 | AC9 |
| mm2_rxcv | Differential receiver signal input (not used in 3-pin mode) | IO | AG8 | AF9 | AC11 |
| mm2_txse0 | Single-ended zero. Used as VM in 4-pin VP_VM mode. | IO | AH8 | AE9 | AD12 |
| mm2_txdat | USB data. Used as VP in 4-pin VP_VM mode. | IO | AB2 | T8 | R5 |
| mm2_txen_n | Transmit enable | IO | V3 | V9 | M4 |
| MM_FSUSB1 | | | | | |
| mm1_rxdm | Vminus receive data (not used in 3- or 4-pin configurations) | IO | AG9 | V2 | AD5 |
| mm1_rxdp | Vplus receive data (not used in 3- or 4-pin configurations) | IO | AF10 | AB2 | AC1 |
| mm1_rxcv | Differential receiver signal input (not used in 3-pin mode) | IO | AF11 | AC3 | AD6 |
| mm1_txse0 | Single-ended zero. Used as VM in 4-pin VP_VM mode. | IO | AG12 | AD4 | AC6 |
| mm1_txdat | USB data. Used as VP in 4-pin VP_VM mode. | IO | AH12 | AD3 | AC7 |
| mm1_txen_n | Transmit enable | IO | AH14 | AD2 | AD9 |
| HSUSB3_TLL | | | | | |
| hsusb3_tll_clk | Dedicated for external transceiver 60-MHz clock input to PHY | O | W8 | W2 | NA |
| hsusb3_tll_stp | Dedicated for external transceiver Stop signal | I | AH3 | M3 | NA |
| hsusb3_tll_dir | dedicated for external transceiver Data direction control from PHY | O | AF3 | L3 | NA |
| hsusb3_tll_nxt | Dedicated for external transceiver Next signal from PHY | O | AE3 | K3 | NA |
| hsusb3_tll_data0 | Dedicated for external transceiver Bidirectional data bus | IO | AD1 | U4 | NA |
| hsusb3_tll_data1 | Dedicated for external transceiver Bidirectional data bus | IO | AE1 | V3 | NA |
| hsusb3_tll_data2 | Dedicated for external transceiver Bidirectional data bus | IO | AD2 | R3 | NA |
| hsusb3_tll_data3 | Dedicated for external transceiver Bidirectional data bus | IO | AC1 | T3 | NA |
| hsusb3_tll_data4 | Dedicated for external transceiver Bidirectional data bus | IO | AF6 | P3 | NA |
| hsusb3_tll_data5 | Dedicated for external transceiver Bidirectional data bus | IO | AE6 | N3 | NA |
| hsusb3_tll_data6 | Dedicated for external transceiver Bidirectional data bus | IO | AF5 | V3 | NA |
| hsusb3_tll_data7 | Dedicated for external transceiver Bidirectional data bus | IO | AE5 | W3 | NA |
| HSUSB2 | | | | | |
| hsusb2_clk | Dedicated for external transceiver 60-MHz clock input to PHY | O | AE7 | AE4 | AC3 |
| hsusb2_stp | Dedicated for external transceiver Stop signal | O | AF7 | AF6 | AC9 |
| hsusb2_dir | Dedicated for external transceiver Data direction control from PHY | I | AG7 | AE6 | AC10 |
| hsusb2_nxt | Dedicated for external transceiver Next signal from PHY | I | AH7 | AF7 | AD11 |
| hsusb2_data0 | Dedicated for external transceiver Bidirectional data bus | IO | AG8 | AF9 | AC11 |
| hsusb2_data1 | Dedicated for external transceiver Bidirectional data bus | IO | AH8 | AE9 | AD12 |
| hsusb2_data2 | Dedicated for external transceiver Bidirectional data bus | IO | AB2 | T8 | R5 |
| hsusb2_data3 | Dedicated for external transceiver Bidirectional data bus | IO | V3 | V9 | M4 |
| hsusb2_data4 | Dedicated for external transceiver Bidirectional data bus additional signals for 12-pin ULPI operation | IO | Y2 | W8 | N4 |
| hsusb2_data5 | Dedicated for external transceiver Bidirectional data bus additional signals for 12-pin ULPI operation | IO | Y3 | U8 | N3 |
| hsusb2_data6 | Dedicated for external transceiver Bidirectional data bus additional signals for 12-pin ULPI operation | IO | Y4 | V8 | M5 |

(2) This pin is not available on the CUS package. For a list of pins not supported on a particular package, see [Table 1-1](#).

Table 2-17. Serial Communication Interfaces – USB Signals Description (continued)

| SIGNAL NAME | DESCRIPTION | TYPE ⁽¹⁾ | BALL BOTTOM (CBB Pkg.) | BALL BOTTOM (CBC Pkg.) | BALL BOTTOM (CUS Pkg.) |
|-------------------|--|---------------------|---------------------------|---------------------------|---------------------------|
| hsusb2_data7 | Dedicated for external transceiver Bidirectional data bus additional signals for 12-pin ULPI operation | IO | AA3 | W7 | N5 |
| HSUSB2_TLL | | | | | |
| hsusb2_tll_clk | Dedicated for external transceiver 60-MHz clock input to PHY | O | AE7 | AE4 | AC3 |
| hsusb2_tll_stp | Dedicated for external transceiver Stop signal | I | AF7 | AF6 | AC9 |
| hsusb2_tll_dir | Dedicated for external transceiver data direction control from PHY | O | AG7 | AE6 | AC10 |
| hsusb2_tll_nxt | Dedicated for external transceiver Next signal from PHY | O | AH7 | AF7 | AD11 |
| hsusb2_tll_data0 | Dedicated for external transceiver Bidirectional data bus | IO | AG8 | AF9 | AC11 |
| hsusb2_tll_data1 | Dedicated for external transceiver Bidirectional data bus | IO | AH8 | AE9 | AD12 |
| hsusb2_tll_data2 | Dedicated for external transceiver Bidirectional data bus | IO | AB2 | T8 | R5 |
| hsusb2_tll_data3 | Dedicated for external transceiver Bidirectional data bus | IO | V3 | V9 | M4 |
| hsusb2_tll_data4 | Dedicated for external transceiver Bidirectional data bus additional signals for 12-pin ULPI operation | IO | Y2 | W8 | N4 |
| hsusb2_tll_data5 | Dedicated for external transceiver Bidirectional data bus additional signals for 12-pin ULPI operation | IO | Y3 | U8 | N3 |
| hsusb2_tll_data6 | Dedicated for external transceiver Bidirectional data bus additional signals for 12-pin ULPI operation | IO | Y4 | V8 | M5 |
| hsusb2_tll_data7 | Dedicated for external transceiver Bidirectional data bus additional signals for 12-pin ULPI operation | IO | AA3 | W7 | N5 |
| HSUSB1 | | | | | |
| hsusb1_clk | Dedicated for external transceiver 60-MHz clock input to PHY | O | AE10 | AB3 | AD3 |
| hsusb1_stp | Dedicated for external transceiver Stop signal | O | AF10 | AB2 | AC1 |
| hsusb1_dir | Dedicated for external transceiver data direction control from PHY | I | AF9 | AA4 | AC4 |
| hsusb1_nxt | Dedicated for external transceiver Next signal from PHY | I | AG9 | V2 | AD5 |
| hsusb1_data0 | Dedicated for external transceiver Bidirectional data bus | IO | AF11 | AC3 | AD6 |
| hsusb1_data1 | Dedicated for external transceiver Bidirectional data bus | IO | AG12 | AD4 | AC6 |
| hsusb1_data2 | Dedicated for external transceiver Bidirectional data bus | IO | AH12 | AD3 | AC7 |
| hsusb1_data3 | Dedicated for external transceiver Bidirectional data bus | IO | AH14 | AD2 | AD9 |
| hsusb1_data4 | Dedicated for external transceiver Bidirectional data bus additional signals for 12-pin ULPI operation | IO | AE11 | Y3 | AC5 |
| hsusb1_data5 | Dedicated for external transceiver Bidirectional data bus additional signals for 12-pin ULPI operation | IO | AH9 | AB1 | AD2 |
| hsusb1_data6 | Dedicated for external transceiver Bidirectional data bus additional signals for 12-pin ULPI operation | IO | AF13 | AE3 | AC8 |
| hsusb1_data7 | Dedicated for external transceiver Bidirectional data bus additional signals for 12-pin ULPI operation | IO | AE13 | AA3 | AD8 |
| HSUSB1_TLL | | | | | |
| hsusb1_tll_clk | Dedicated for external transceiver 60-MHz clock input to PHY | O | AE10 | AB3 | AD3 |
| hsusb1_tll_stp | Dedicated for external transceiver Stop signal | I | AF10 | AB2 | AC1 |
| hsusb1_tll_dir | Dedicated for external transceiver data direction control from PHY | O | AF9 | AA4 | AC4 |
| hsusb1_tll_nxt | Dedicated for external transceiver Next signal from PHY | O | AG9 | V2 | AD5 |
| hsusb1_tll_data0 | Dedicated for external transceiver Bidirectional data bus | IO | AF11 | AC3 | AD6 |
| hsusb1_tll_data1 | Dedicated for external transceiver Bidirectional data bus | IO | AG12 | AD4 | AC6 |
| hsusb1_tll_data2 | Dedicated for external transceiver Bidirectional data bus | IO | AH12 | AD3 | AC7 |
| hsusb1_tll_data3 | Dedicated for external transceiver Bidirectional data bus | IO | AH14 | AD2 | AD9 |
| hsusb1_tll_data4 | Dedicated for external transceiver Bidirectional data bus additional signals for 12-pin ULPI operation | IO | AE11 | Y3 | AC5 |
| hsusb1_tll_data5 | Dedicated for external transceiver Bidirectional data bus additional signals for 12-pin ULPI operation | IO | AH9 | AB1 | AD2 |
| hsusb1_tll_data6 | Dedicated for external transceiver Bidirectional data bus additional signals for 12-pin ULPI operation | IO | AF13 | AE3 | AC8 |
| hsusb1_tll_data7 | Dedicated for external transceiver Bidirectional data bus additional signals for 12-pin ULPI operation | IO | AE13 | AA3 | AD8 |

2.5.4 Removable Media Interfaces

Table 2-18. Removable Media Interfaces – MMC/SDIO Signals Description

| SIGNAL NAME | DESCRIPTION | TYPE ⁽¹⁾ | BALL BOTTOM (CBB Pkg.) | BALL BOTTOM (CBC Pkg.) | BALL BOTTOM (CUS Pkg.) |
|--|--|---------------------|------------------------|------------------------|------------------------|
| MULTIMEDIA MEMORY CARD (MMC1) / SECURE DIGITAL IO (SDIO1) | | | | | |
| mmc1_clk | MMC/SD Output Clock | O | N28 | N19 | M23 |
| mmc1_cmd | MMC/SD command signal | IO | M27 | L18 | L23 |
| mmc1_dat0 | MMC/SD Card Data bit 0 / SPI Serial Input | IO | N27 | M19 | M22 |
| mmc1_dat1 | MMC/SD Card Data bit 1 | IO | N26 | M18 | M21 |
| mmc1_dat2 | MMC/SD Card Data bit 2 | IO | N25 | K18 | M20 |
| mmc1_dat3 | MMC/SD Card Data bit 3 | IO | P28 | N20 | N23 |
| mmc1_dat4 | MMC/SD Card Data bit 4 | IO | P27 | M20 | N22 |
| mmc1_dat5 | MMC/SD Card Data bit 5 | IO | P26 | P17 | N21 |
| mmc1_dat6 | MMC/SD Card Data bit 6 | IO | R27 | P18 | N20 |
| mmc1_dat7 | MMC/SD Card Data bit 7 | IO | R25 | P19 | P24 |
| MULTIMEDIA MEMORY CARD (MMC2) / SECURE DIGITAL IO (SDIO2) | | | | | |
| mmc2_clk | MMC/SD Output Clock | O | AE2 | W10 | Y1 |
| mmc2_dir_dat0 | Direction control for DAT0 signal case an external transceiver used | O | AE4 | V10 | AB2 |
| mmc2_dir_dat1 | Direction control for DAT1 and DAT3 signals case an external transceiver used | O | AH3 | M3 | AA2 |
| mmc2_dir_dat2 | Direction control for DAT2 signal case an external transceiver used | O | AF19 | E4 | AC17 |
| mmc2_dir_dat3 | Direction control for DAT4, DAT5, DAT6, and DAT7 signals case an external transceiver used | O | AE21 | G3 | AB16 |
| mmc2_clkln | MMC/SD input Clock | I | AE3 | K3 | AA1 |
| mmc2_dat0 | MMC/SD Card Data bit 0 | IO | AH5 | T10 | AB3 |
| mmc2_dat1 | MMC/SD Card Data bit 1 | IO | AH4 | T9 | Y3 |
| mmc2_dat2 | MMC/SD Card Data bit 2 | IO | AG4 | U10 | W3 |
| mmc2_dat3 | MMC/SD Card Data bit 3 | IO | AF4 | U9 | V3 |
| mmc2_dat4 | MMC/SD Card Data bit 4 | IO | AE4 / AB3 | P9 / V10 | AB2 / T5 |
| mmc2_dat5 | MMC/SD Card Data bit 5 | IO | AH3 / AB4 | M3/P8 | AA2 / R4 |
| mmc2_dat6 | MMC/SD Card Data bit 6 | IO | AF3 / AA4 | L3/P7 | Y2 / T4 |
| mmc2_dat7 | MMC/SD Card Data bit 7 | IO | AE3 / AC2 | K3/R7 | AA1 / T6 |
| mmc2_dir_cmd | Direction control for CMD signal case an external transceiver is used | O | AF3 | L3 | Y2 |
| mmc2_cmd | MMC/SD command signal | IO | AG5 | R10 | AB5 |
| MULTIMEDIA MEMORY CARD (MMC3) / SECURE DIGITAL IO (SDIO3) | | | | | |
| mmc3_clk | MMC/SD Output Clock | O | AB1 / AF10 | R9 / AB2 | AC1 |
| mmc3_cmd | MMC/SD command signal | IO | AC3 / AE10 | R8 / AB3 | AD3 |
| mmc3_dat0 | MMC/SD Card Data bit 0 / SPI Serial Input | IO | AE4 / AE11 | V10 / Y3 | AB2 / AC5 |
| mmc3_dat1 | MMC/SD Card Data bit 1 | IO | AH3 / AH9 | M3/AB1 | AA2 / AD2 |
| mmc3_dat2 | MMC/SD Card Data bit 2 | IO | AF3 / AF13 | L3/AE3 | Y2 / AC8 |
| mmc3_dat3 | MMC/SD Card Data bit 3 | IO | AE3 / AE13 | K3/AA3 | AA1 / AD8 |
| mmc3_dat4 | MMC/SD Card Data bit 4 | IO | AF11 | AC3 | AD6 |
| mmc3_dat5 | MMC/SD Card Data bit 5 | IO | AG9 | V2 | AD5 |
| mmc3_dat6 | MMC/SD Card Data bit 6 | IO | AF9 | AA4 | AC4 |
| mmc3_dat7 | MMC/SD Card Data bit 7 | IO | AH14 | AD2 | AD9 |

(1) Type = Ball type for this specific function (I = Input, O = Output, Z = high-impedance, D = Open Drain, DS = Differential, A = Analog)

2.5.5 Test Interfaces

Table 2-19. Test Interfaces – ETK Signals Description

| SIGNAL NAME | DESCRIPTION | TYPE ⁽¹⁾ | BALL BOTTOM (CBB Pkg.) | BALL BOTTOM (CBC Pkg.) | BALL BOTTOM (CUS Pkg.) |
|-------------|-----------------|---------------------|---------------------------|---------------------------|---------------------------|
| etk_ctl | ETK trace ctl | O | AE10 | AB2 | AD3 |
| etk_clk | ETK trace clock | O | AF10 | AB3 | AC1 |
| etk_d0 | ETK data 0 | O | AF11 | AC3 | AD6 |
| etk_d1 | ETK data 1 | O | AG12 | AD4 | AC6 |
| etk_d2 | ETK data 2 | O | AH12 | AD3 | AC7 |
| etk_d3 | ETK data 3 | O | AE13 | AA3 | AD8 |
| etk_d4 | ETK data 4 | O | AE11 | Y3 | AC5 |
| etk_d5 | ETK data 5 | O | AH9 | AB1 | AD2 |
| etk_d6 | ETK data 6 | O | AF13 | AE3 | AC8 |
| etk_d7 | ETK data 7 | O | AH14 | AD2 | AD9 |
| etk_d8 | ETK data 8 | O | AF9 | AA4 | AC4 |
| etk_d9 | ETK data 9 | O | AG9 | V2 | AD5 |
| etk_d10 | ETK data 10 | O | AE7 | AE4 | AC3 |
| etk_d11 | ETK data 11 | O | AF7 | AF6 | AC9 |
| etk_d12 | ETK data 12 | O | AG7 | AE6 | AC10 |
| etk_d13 | ETK data 13 | O | AH7 | AF7 | AD11 |
| etk_d14 | ETK data 14 | O | AG8 | AF9 | AC11 |
| etk_d15 | ETK data 15 | O | AH8 | AE9 | AD12 |

(1) Type = Ball type for this specific function (I = Input, O = Output, Z = high-impedance, D = Open Drain, DS = Differential, A = Analog)

Table 2-20. Test Interfaces – JTAG Signals Description

| SIGNAL NAME | DESCRIPTION | TYPE ⁽¹⁾ | BALL BOTTOM (CBB Pkg.) | BALL BOTTOM (CBC Pkg.) | BALL BOTTOM (CUS Pkg.) |
|----------------|---------------------|---------------------|------------------------|------------------------|------------------------|
| jtag_nrst | Test Reset | I | AA17 | U15 | AB7 |
| jtag_tck | Test Clock | I | AA13 | V14 | AB6 |
| jtag_rtck | ARM Clock Emulation | O | AA12 | W13 | AA7 |
| jtag_tms_tmssc | Test Mode Select | IO | AA18 | V15 | AA9 |
| jtag_tdi | Test Data Input | I | AA20 | U16 | AB10 |
| jtag_tdo | Test Data Output | O | AA19 | Y13 | AB9 |
| jtag_emu0 | Test emulation 0 | IO | AA11 | Y15 | AC24 |
| jtag_emu1 | Test emulation 1 | IO | AA10 | Y14 | AD24 |

(1) Type = Ball type for this specific function (I = Input, O = Output, Z = high-impedance, D = Open Drain, DS = Differential, A = Analog)

Table 2-21. Test Interfaces – SDTI Signals Description

| SIGNAL NAME | DESCRIPTION | TYPE ⁽¹⁾ | BALL BOTTOM (CBB Pkg.) | BALL BOTTOM (CBC Pkg.) | BALL BOTTOM (CUS Pkg.) | SUBSYSTEM SIGNAL MULTIPLEXING ⁽²⁾ |
|-------------|---|---------------------|------------------------|------------------------|------------------------|--|
| sdti_clk | Serial clock dual edge | O | AF7 / AA11 / AG8 | AF6 / Y15 / AF9 | AC9 / AC24 / AC11 | etk_d11 / jtag_emu0 / etk_d14 |
| sdti_txd0 | Serial data out (System Trace messages) | O | AG7 / AA10 / AA11 | AE6 / Y14 / Y15 | AC10 / AD24 / AC24 | etk_d12 / jtag_emu1 / jtag_emu0 |
| sdti_txd1 | Serial data out (System Trace messages) | O | AH7 / AA10 | AF7 / Y14 | AD11 / AD24 | etk_d13 / jtag_emu1 |
| sdti_txd2 | Serial data out (System Trace messages) | O | AG8 | AF9 | AC11 | etk_d14 |
| sdti_txd3 | Serial data out (System Trace messages) | O | AH8 | AE9 | AD12 | etk_d15 |

(1) Type = Ball type for this specific function (I = Input, O = Output, Z = high-impedance, D = Open Drain, DS = Differential, A = Analog)

(2) The subsystem pin multiplexing options are not described in and

Table 2-22. Test Interfaces – HWDBG Signals Description

| SIGNAL NAME | DESCRIPTION | TYPE ⁽¹⁾ | BALL BOTTOM (CBB Pkg.) | BALL BOTTOM (CBC Pkg.) | BALL BOTTOM (CUS Pkg.) |
|-------------|-----------------|---------------------|------------------------|------------------------|------------------------|
| hw_dbg0 | Debug signal 0 | O | A24 / AF10 | C23/AB2 | AC1/A22 |
| hw_dbg1 | Debug signal 1 | O | A23 / AE10 | D23/AB3 | AD3/E18 |
| hw_dbg2 | Debug signal 2 | O | C27/ AF11 | C26/AC3 | AD6/J19 |
| hw_dbg3 | Debug signal 3 | O | C23 / AG12 | B23/AD4 | AC6/H24 |
| hw_dbg4 | Debug signal 4 | O | B24 / AH12 | A24/AD3 | AC7/G19 |
| hw_dbg5 | Debug signal 5 | O | C24 / AE13 | B24/AA3 | AD8/F19 |
| hw_dbg6 | Debug signal 6 | O | D24 / AE11 | D24/Y3 | AC5/G20 |
| hw_dbg7 | Debug signal 7 | O | A25 / AH9 | C24/AB1 | AD2/B21 |
| hw_dbg8 | Debug signal 8 | O | B25 / AF13 | D25/AE3 | AC8/F21 |
| hw_dbg9 | Debug signal 9 | O | C26 / AH14 | E26/AD2 | AD9/G21 |
| hw_dbg10 | Debug signal 10 | O | B23 / AF9 | A23/AA4 | AC4/F18 |
| hw_dbg11 | Debug signal 11 | O | D25 / AG9 | D26/V2 | AD5/J20 |
| hw_dbg12 | Debug signal 12 | O | D28 / AE7 | G25/AE4 | AC3/G22 |
| hw_dbg13 | Debug signal 13 | O | D26 / AF7 | K24/AF6 | AC9/E22 |
| hw_dbg14 | Debug signal 14 | O | E26 / AG7 | G26/AE6 | AC10/D24 |
| hw_dbg15 | Debug signal 15 | O | F28 / AH7 | H25/AF7 | AD11/E23 |
| hw_dbg16 | Debug signal 16 | O | F27 / AG8 | H26/AF9 | AC11/E24 |
| hw_dbg17 | Debug signal 17 | O | G26 / AH8 | J26/AE9 | AD12/F23 |

(1) Type = Ball type for this specific function (I = Input, O = Output, Z = high-impedance, D = Open Drain, DS = Differential, A = Analog)

2.5.6 Miscellaneous

Table 2-23. Miscellaneous – GP Timer Signals Description

| SIGNAL NAME | DESCRIPTION | TYPE ⁽¹⁾ | BALL BOTTOM (CBB Pkg.) | BALL BOTTOM (CBC Pkg.) | BALL BOTTOM (CUS Pkg.) |
|---------------|------------------------------|---------------------|---------------------------|---------------------------|---------------------------|
| gpt8_pwm_evt | PWM or event for GP timer 8 | IO | N8 / AD25 / V3 | C5 / AD21/ V9 | G4/ M4 |
| gpt9_pwm_evt | PWM or event for GP timer 9 | IO | T8 / AB26 / Y2 | B4 / W8 / Y24 | F4 / N4 |
| gpt10_pwm_evt | PWM or event for GP timer 10 | IO | R8 / AB25 / Y3 | C4 / U8 / AA24 | G5 / N3 |
| gpt11_pwm_evt | PWM or event for GP timer 11 | IO | P8 / AA25 / Y4 | B5 / V8 / AD22 | F3 / M5 |

(1) Type = Ball type for this specific function (I = Input, O = Output, Z = high-impedance, D = Open Drain, DS = Differential, A = Analog)

2.5.7 General-Purpose IOs

Table 2-24. General-Purpose IOs Signals Description⁽¹⁾

| SIGNAL NAME | DESCRIPTION | TYPE ⁽²⁾ | BALL BOTTOM (CBB Pkg.) | BALL BOTTOM (CBC Pkg.) | BALL BOTTOM (CUS Pkg.) |
|-------------|-----------------------|---------------------|---------------------------|---------------------------|---------------------------|
| gpio_0 | General-purpose IO 0 | IO | AF26 | V16 | W16 |
| gpio_1 | General-purpose IO 1 | IO | AF25 | W15 | Y13 |
| gpio_2 | General-purpose IO 2 | IO | AH26 | F3 | AB12 |
| gpio_3 | General-purpose IO 3 | IO | AG26 | D3 | AC16 |
| gpio_4 | General-purpose IO 4 | IO | AE14 | C3 | AD17 |
| gpio_5 | General-purpose IO 5 | IO | AF18 | E3 | AD18 |
| gpio_6 | General-purpose IO 6 | IO | AF19 | E4 | AC17 |
| gpio_7 | General-purpose IO 7 | IO | AE21 | G3 | AB16 |
| gpio_8 | General-purpose IO 8 | IO | AF21 | D4 | AA15 |
| gpio_9 | General-purpose IO 9 | IO | AF22 | V12 | AD23 |
| gpio_10 | General-purpose IO 10 | IO | AG25 | AE14 | Y7 |
| gpio_11 | General-purpose IO 11 | IO | AA11 | Y15 | AC24 |
| gpio_12 | General-purpose IO 12 | IO | AF10 | AB2 | AC1 |
| gpio_13 | General-purpose IO 13 | IO | AE10 | AB3 | AD3 |
| gpio_14 | General-purpose IO 14 | IO | AF11 | AC3 | AD6 |
| gpio_15 | General-purpose IO 15 | IO | AG12 | AD4 | AC6 |
| gpio_16 | General-purpose IO 16 | IO | AH12 | AD3 | AC7 |
| gpio_17 | General-purpose IO 17 | IO | AE13 | AA3 | AD8 |
| gpio_18 | General-purpose IO 18 | IO | AE11 | Y3 | AC5 |
| gpio_19 | General-purpose IO 19 | IO | AH9 | AB1 | AD2 |
| gpio_20 | General-purpose IO 20 | IO | AF13 | AE3 | AC8 |
| gpio_21 | General-purpose IO 21 | IO | AH14 | AD2 | AD9 |
| gpio_22 | General-purpose IO 22 | IO | AF9 | AA4 | AC4 |
| gpio_23 | General-purpose IO 23 | IO | AG9 | V2 | AD5 |
| gpio_24 | General-purpose IO 24 | IO | AE7 | AE4 | AC3 |
| gpio_25 | General-purpose IO 25 | IO | AF7 | AF6 | AC9 |
| gpio_26 | General-purpose IO 26 | IO | AG7 | AE6 | AC10 |
| gpio_27 | General-purpose IO 27 | IO | AH7 | AF7 | AD11 |
| gpio_28 | General-purpose IO 28 | IO | AG8 | AF9 | AC11 |
| gpio_29 | General-purpose IO 29 | IO | AH8 | AE9 | AD12 |
| gpio_30 | General-purpose IO 30 | IO | AF24 | AD7 | Y10 |
| gpio_31 | General-purpose IO 31 | IO | AA10 | Y14 | AD24 |
| gpio_34 | General-purpose IO 34 | IO | N4 | J2 | K4 |
| gpio_35 | General-purpose IO 35 | IO | M4 | H1 | K3 |
| gpio_36 | General-purpose IO 36 | IO | L4 | H2 | K2 |
| gpio_37 | General-purpose IO 37 | IO | K4 | G2 | J4 |
| gpio_38 | General-purpose IO 38 | IO | T3 | F1 | J3 |
| gpio_39 | General-purpose IO 39 | IO | R3 | F2 | J2 |
| gpio_40 | General-purpose IO 40 | IO | N3 | E1 | J1 |
| gpio_41 | General-purpose IO 41 | IO | M3 | E2 | H1 |
| gpio_42 | General-purpose IO 42 | IO | L3 | D1 | H2 |
| gpio_43 | General-purpose IO 43 | IO | K3 | D2 | G2 |
| gpio_44 | General-purpose IO 44 | IO | H2 | V1 | R2 |
| gpio_45 | General-purpose IO 45 | IO | K2 | Y1 | T2 |
| gpio_46 | General-purpose IO 46 | IO | P1 | T1 | U1 |
| gpio_47 | General-purpose IO 47 | IO | R1 | U2 | R3 |

(1) NA in table stands for "Not Applicable".

(2) Type = Ball type for this specific function (I = Input, O = Output, Z = high-impedance, D = Open Drain, DS = Differential, A = Analog)

Table 2-24. General-Purpose IOs Signals Description (continued)

| SIGNAL NAME | DESCRIPTION | TYPE ⁽²⁾ | BALL BOTTOM (CBB Pkg.) | BALL BOTTOM (CBC Pkg.) | BALL BOTTOM (CUS Pkg.) |
|-------------|-----------------------|---------------------|---------------------------|---------------------------|---------------------------|
| gpio_48 | General-purpose IO 48 | IO | R2 | U1 | T3 |
| gpio_49 | General-purpose IO 49 | IO | T2 | P1 | U2 |
| gpio_50 | General-purpose IO 50 | IO | W1 | L2 | V1 |
| gpio_51 | General-purpose IO 51 | IO | Y1 | M2 | V2 |
| gpio_52 | General-purpose IO 52 | IO | H3 | AD1 | NA |
| gpio_53 | General-purpose IO 53 | IO | V8 | A3 | NA |
| gpio_54 | General-purpose IO 54 | IO | U8 | B6 | D2 |
| gpio_55 | General-purpose IO 55 | IO | T8 | B4 | F4 |
| gpio_56 | General-purpose IO 56 | IO | R8 | C4 | G5 |
| gpio_57 | General-purpose IO 57 | IO | P8 | B5 | F3 |
| gpio_58 | General-purpose IO 58 | IO | N8 | C5 | G4 |
| gpio_59 | General-purpose IO 59 | IO | T4 | N1 | W2 |
| gpio_60 | General-purpose IO 60 | IO | G3 | K2 | K5 |
| gpio_61 | General-purpose IO 61 | IO | U3 | J1 | L1 |
| gpio_62 | General-purpose IO 62 | IO | H1 | AC6 | E1 |
| gpio_63 | General-purpose IO 63 | IO | L8 | AC8 | NA |
| gpio_64 | General-purpose IO 64 | IO | K8 | B3 | NA |
| gpio_65 | General-purpose IO 65 | IO | J8 | C6 | C2 |
| gpio_66 | General-purpose IO 66 | IO | D28 | G25 | G22 |
| gpio_67 | General-purpose IO 67 | IO | D26 | K24 | E22 |
| gpio_68 | General-purpose IO 68 | IO | D27 | M25 | F22 |
| gpio_69 | General-purpose IO 69 | IO | E27 | F26 | J21 |
| gpio_70 | General-purpose IO 70 | IO | AG22 | AE21 | AC19 |
| gpio_71 | General-purpose IO 71 | IO | AH22 | AE22 | AB19 |
| gpio_72 | General-purpose IO 72 | IO | AG23 | AE23 | AD20 |
| gpio_73 | General-purpose IO 73 | IO | AH23 | AE24 | AC20 |
| gpio_74 | General-purpose IO 74 | IO | AG24 | AD23 | AD21 |
| gpio_75 | General-purpose IO 75 | IO | AH24 | AD24 | AC21 |
| gpio_76 | General-purpose IO 76 | IO | E26 | G26 | D24 |
| gpio_77 | General-purpose IO 77 | IO | F28 | H25 | E23 |
| gpio_78 | General-purpose IO 78 | IO | F27 | H26 | E24 |
| gpio_79 | General-purpose IO 79 | IO | G26 | J26 | F23 |
| gpio_80 | General-purpose IO 80 | IO | AD28 | AC26 | AC22 |
| gpio_81 | General-purpose IO 81 | IO | AD27 | AD26 | AC23 |
| gpio_82 | General-purpose IO 82 | IO | AB28 | AA25 | AB22 |
| gpio_83 | General-purpose IO 83 | IO | AB27 | Y25 | Y22 |
| gpio_84 | General-purpose IO 84 | IO | AA28 | AA26 | W22 |
| gpio_85 | General-purpose IO 85 | IO | AA27 | AB26 | V22 |
| gpio_86 | General-purpose IO 86 | IO | G25 | L25 | J22 |
| gpio_87 | General-purpose IO 87 | IO | H27 | L26 | G23 |
| gpio_88 | General-purpose IO 88 | IO | H26 | M24 | G24 |
| gpio_89 | General-purpose IO 89 | IO | H25 | M26 | H23 |
| gpio_90 | General-purpose IO 90 | IO | E28 | F25 | D23 |
| gpio_91 | General-purpose IO 91 | IO | J26 | N24 | K22 |
| gpio_92 | General-purpose IO 92 | IO | AC27 | AC25 | V21 |
| gpio_93 | General-purpose IO 93 | IO | AC28 | AB25 | W21 |
| gpio_94 | General-purpose IO 94 | IO | A24 | C23 | A22 |
| gpio_95 | General-purpose IO 95 | IO | A23 | D23 | E18 |
| gpio_96 | General-purpose IO 96 | IO | C25 | C25 | B22 |
| gpio_97 | General-purpose IO 97 | IO | C27 | C26 | J19 |

Table 2-24. General-Purpose IOs Signals Description (continued)

| SIGNAL NAME | DESCRIPTION | TYPE ⁽²⁾ | BALL BOTTOM (CBB Pkg.) | BALL BOTTOM (CBC Pkg.) | BALL BOTTOM (CUS Pkg.) |
|-------------|------------------------|---------------------|---------------------------|---------------------------|---------------------------|
| gpio_98 | General-purpose IO 98 | IO | C23 | B23 | H24 |
| gpio_99 | General-purpose IO 99 | I | AG17 | AE16 | AB18 |
| gpio_100 | General-purpose IO 100 | I | AH17 | AE15 | AC18 |
| gpio_101 | General-purpose IO 101 | IO | B24 | A24 | G19 |
| gpio_102 | General-purpose IO 102 | IO | C24 | B24 | F19 |
| gpio_103 | General-purpose IO 103 | IO | D24 | D24 | G20 |
| gpio_104 | General-purpose IO 104 | IO | A25 | C24 | B21 |
| gpio_105 | General-purpose IO 105 | IO | K28 | P25 | L24 |
| gpio_106 | General-purpose IO 106 | IO | L28 | P26 | K24 |
| gpio_107 | General-purpose IO 107 | IO | K27 | N25 | J23 |
| gpio_108 | General-purpose IO 108 | IO | L27 | N26 | K23 |
| gpio_109 | General-purpose IO 109 | IO | B25 | D25 | F21 |
| gpio_110 | General-purpose IO 110 | IO | C26 | E26 | G21 |
| gpio_111 | General-purpose IO 111 | IO | B26 | E25 | C22 |
| gpio_112 | General-purpose IO 112 | I | AG19 | AD17 | NA |
| gpio_113 | General-purpose IO 113 | I | AH19 | AD16 | NA |
| gpio_114 | General-purpose IO 114 | I | AG18 | AE18 | NA |
| gpio_115 | General-purpose IO 115 | I | AH18 | AE17 | NA |
| gpio_116 | General-purpose IO 116 | IO | P21 | U18 | V20 |
| gpio_117 | General-purpose IO 117 | IO | N21 | R18 | T21 |
| gpio_118 | General-purpose IO 118 | IO | R21 | T18 | V19 |
| gpio_119 | General-purpose IO 119 | IO | M21 | R19 | R20 |
| gpio_120 | General-purpose IO 120 | IO | N28 / T28 | W19 / N19 | M23 / R21 |
| gpio_121 | General-purpose IO 121 | IO | M27 / T25 | U20 / L18 | L23 / R23 |
| gpio_122 | General-purpose IO 122 | IO | N27 / R28 | V19 / M19 | M22 / P23 |
| gpio_123 | General-purpose IO 123 | IO | N26 | M18 | M21 |
| gpio_124 | General-purpose IO 124 | IO | N25 / T26 | W18 / K18 | M20/R22 |
| gpio_125 | General-purpose IO 125 | IO | P28 / T27 | V20 / N20 | N23/T24 |
| gpio_126 | General-purpose IO 126 | IO | D25 / P27 | M20 / D26 | J20 / N22 |
| gpio_127 | General-purpose IO 127 | IO | P26 | P17 | N21 |
| gpio_128 | General-purpose IO 128 | IO | R27 | P18 | N20 |
| gpio_129 | General-purpose IO 129 | IO | R25 | P19 | P24 |
| gpio_130 | General-purpose IO 130 | IO | AE2 / U28 | Y20 / W10 | Y1 / T23 |
| gpio_131 | General-purpose IO 131 | IO | AG5 / U27 | V18 / R10 | AB5 / U24 |
| gpio_132 | General-purpose IO 132 | IO | AH5 | T10 | AB3 |
| gpio_133 | General-purpose IO 133 | IO | AH4 | T9 | Y3 |
| gpio_134 | General-purpose IO 134 | IO | AG4 | U10 | W3 |
| gpio_135 | General-purpose IO 135 | IO | AF4 | U9 | V3 |
| gpio_136 | General-purpose IO 136 | IO | AE4 | V10 | AB2 |
| gpio_137 | General-purpose IO 137 | IO | AH3 | M3 | AA2 |
| gpio_138 | General-purpose IO 138 | IO | AF3 | L3 | Y2 |
| gpio_139 | General-purpose IO 139 | IO | AE3 | K3 | AA1 |
| gpio_140 | General-purpose IO 140 | IO | AF6 | N3 | V6 |
| gpio_141 | General-purpose IO 141 | IO | AE6 | P3 | V5 |
| gpio_142 | General-purpose IO 142 | IO | AF5 | V3 | W4 |
| gpio_143 | General-purpose IO 143 | IO | AE5 | W3 | V4 |
| gpio_144 | General-purpose IO 144 | IO | AB26 | Y24 | NA |
| gpio_145 | General-purpose IO 145 | IO | AB25 | AA24 | NA |
| gpio_146 | General-purpose IO 146 | IO | AA25 | AD22 | NA |
| gpio_147 | General-purpose IO 147 | IO | AD25 | AD21 | NA |

Table 2-24. General-Purpose IOs Signals Description (continued)

| SIGNAL NAME | DESCRIPTION | TYPE ⁽²⁾ | BALL BOTTOM (CBB Pkg.) | BALL BOTTOM (CBC Pkg.) | BALL BOTTOM (CUS Pkg.) |
|-------------|------------------------|---------------------|---------------------------|---------------------------|---------------------------|
| gpio_148 | General-purpose IO 148 | IO | AA8 | L4 | W7 |
| gpio_149 | General-purpose IO 149 | IO | AA9 | R2 | W6 |
| gpio_150 | General-purpose IO 150 | IO | W8 | W2 | AC2 |
| gpio_151 | General-purpose IO 151 | IO | Y8 | H3 | V7 |
| gpio_152 | General-purpose IO 152 | IO | AE1 | V3 | NA |
| gpio_153 | General-purpose IO 153 | IO | AD1 | U4 | NA |
| gpio_154 | General-purpose IO 154 | IO | AD2 | R3 | NA |
| gpio_155 | General-purpose IO 155 | IO | AC1 | T3 | NA |
| gpio_156 | General-purpose IO 156 | IO | Y21 | U19 | W19 |
| gpio_157 | General-purpose IO 157 | IO | AA21 | V17 | AB20 |
| gpio_158 | General-purpose IO 158 | IO | V21 | U17 | W18 |
| gpio_159 | General-purpose IO 159 | IO | U21 | T20 | Y18 |
| gpio_160 | General-purpose IO 160 | IO | T21 | T19 | AA18 |
| gpio_161 | General-purpose IO 161 | IO | K26 | P20 | AA19 |
| gpio_162 | General-purpose IO 162 | IO | W21 | T17 | V18 |
| gpio_163 | General-purpose IO 163 | IO | H18 | F23 | A23 |
| gpio_164 | General-purpose IO 164 | IO | H19 | F24 | B23 |
| gpio_165 | General-purpose IO 165 | IO | H20 | H24 | B24 |
| gpio_166 | General-purpose IO 166 | IO | H21 | G24 | C23 |
| gpio_167 | General-purpose IO 167 | IO | B23 | A23 | F18 |
| gpio_168 | General-purpose IO 168 | IO | AF15 | C2 | AC15 |
| gpio_169 | General-purpose IO 169 | IO | U26 | W20 | U23 |
| gpio_170 | General-purpose IO 170 | IO | J25 | J23 | A24 |
| gpio_171 | General-purpose IO 171 | IO | AB3 | P9 | T5 |
| gpio_172 | General-purpose IO 172 | IO | AB4 | P8 | R4 |
| gpio_173 | General-purpose IO 173 | IO | AA4 | P7 | T4 |
| gpio_174 | General-purpose IO 174 | IO | AC2 | R7 | T6 |
| gpio_175 | General-purpose IO 175 | IO | AC3 | R8 | NA |
| gpio_176 | General-purpose IO 176 | IO | AB1 | R9 | NA |
| gpio_177 | General-purpose IO 177 | IO | AB2 | T8 | R5 |
| gpio_178 | General-purpose IO 178 | IO | AA3 | W7 | N5 |
| gpio_179 | General-purpose IO 179 | IO | Y2 | W8 | N4 |
| gpio_180 | General-purpose IO 180 | IO | Y3 | U8 | N3 |
| gpio_181 | General-purpose IO 181 | IO | Y4 | V8 | M5 |
| gpio_182 | General-purpose IO 182 | IO | V3 | V9 | M4 |
| gpio_183 | General-purpose IO 183 | IO | AE15 | C1 | AC14 |
| gpio_184 | General-purpose IO 184 | IO | AF14 | AB4 | AC13 |
| gpio_185 | General-purpose IO 185 | IO | AG14 | AC4 | AC12 |
| gpio_186 | General-purpose IO 186 | IO | AE22 | W11 | AA6 |
| gpio_188 | General-purpose IO 188 | IO | U25 | W17 | W24 |
| gpio_189 | General-purpose IO 189 | IO | V28 | Y18 | V23 |
| gpio_190 | General-purpose IO 190 | IO | V27 | Y19 | W23 |
| gpio_191 | General-purpose IO 191 | IO | V26 | Y17 | T22 |

2.5.8 Power Supplies

Table 2-25. Power Supplies Signals Description⁽¹⁾

| SIGNAL NAME | DESCRIPTION | BALL BOTTOM (CBB Pkg.) | BALL TOP (CBB Pkg.) | BALL BOTTOM (CBC Pkg.) | BALL TOP (CBC Pkg.) | BALL BOTTOM (CUS Pkg.) |
|---------------|---|--|--|---|------------------------|--|
| vdd_mpu_iva | ARM/IVA power domain | Y9 / W9 / T9 / R9 / M9 / L9 / J9 / Y10 / U10 / T10 / R10 / N10 / M10 / L10 / J10 / Y11 / W11 / K11 / J11 / W12 / K13 / Y14 / K14 / J14 / Y15 / W15 / J15 | NA | H7/ N7/ U7/ V7/ N8/ G9/ L9/ M9/ W9/ Y9/ M10/ P10/ K11/ U11/ V11/ Y11/ G12/ D13/ U13 | NA | W13/ W12/ V13/ V12/ U13/ U12/ T8/ T7/ R8/ R7/ R6/ N8/ N7/ N6/ M12/ M8/ M7/ M6/ L12/ L11/ J10/ J9/ H10/ H9/ G10/ G9/F10 |
| vdd_core | Core power domain | AC4 / J4 / H4 / D8 / AE9 / D9 / D15 / Y16 / AE18 / Y18 / W18 / K18 / J18 / AE19 / Y19 / U19 / T19 / N19 / M19 / J19 / Y20 / W20 / V20 / U20 / P20 / N20 / K20 / J20 / D22 / D23 / AE24 / M25 / L25 / E25 | NA | M7/ T7/ Y8/ G11/ Y12/ D15/ M17/ G18/ H20/ R20/ AC21 | NA | T20/ T19/ T18/ T17/ R19/ R18/ R17/ M15/ M14/ L15/ L14/ K19/ K18/ K17/ J18/ J17/ H13/ H12/ G13/ G12/ F13/ F12 |
| cap_vdd_wkup | Wakeup/EMU/memory domains, connect capacitor | AA15 | NA | K14 | NA | Y12 |
| cap_vdd_d | Decoupling capacitor | AH20 | NA | AE19 | NA | NA |
| vdds_dpll_dll | DLL IO power domain (1.8 V): internal connection to PLL_VDDS, power supply for 3PLL (1.8 V) | K15 | NA | K13 | NA | G18 |
| vdda_dac | Video DAC power plane | V25 | NA | V25 | NA | AB13 |
| vssa_dac | Video DAC ground plane | Y26 | NA | V24 | NA | AB15 |
| vdds | IO power plane | AD3 / AD4 / W4 / AF8 / AE8 / AF16 / AE16 / AF23 / AE23 / F25 / F26 / AG27/ AE27/ AG20/ H28/ AG21 | NA | G4/ M4/ T4/ Y4/ L7/ AC7/ D9/ AE10/ C11/ J15/ AC15/ A18/ J18/ AC18/ AD20/ E24/ L24/ T24/ W24/ AC24 | NA | Y9 / W10 / W9 / V10 / V9 / U10 / N19 / N18 / N17 / M19 / M18 / M17 |
| vdds_mem | Memory IO power plane | U1 / J1 / F1 / J2 / F2 / R4 / B5 / A5 / AH6 / B8 / A8 / B12 / A12 / D16 / C16 / B18 / A18 / B22 / A22 / G28 / C28 | AC5 / P1 / H1 / F23 / E1 / C23 / A4 / A7 / A10 / A15 / A18 | | | K8 / K7 / K6 / J8 / J7 / J6 / H15 / G16 / G15 / F16 / F15 / E16 |
| vdds_dpll_per | Peripheral DPLLs power rail | AA16 | NA | U14 | NA | U17 |
| vdds_wkup_bg | For wakeup LDO and VDDA (2 LDOs SRAM and BG) | AA14 | NA | W14 | NA | AA13 |

(1) NA in this table stands for "Not applicable".

Table 2-25. Power Supplies Signals Description (continued)

| SIGNAL NAME | DESCRIPTION | BALL BOTTOM (CBB Pkg.) | BALL TOP (CBB Pkg.) | BALL BOTTOM (CBC Pkg.) | BALL TOP (CBC Pkg.) | BALL BOTTOM (CUS Pkg.) |
|----------------------|---|--|---|--|--|--|
| vss | Ground | AG2 / U2 / B2 / AG3 / W3 / P3 / J3 / E3 / A3 / P4 / E4 / AG6 / D7 / C7 / V9 / U9 / P9 / N9 / K9 / W10 / V10 / P10 / K10 / D10 / C10 / AF12 / AE12 / Y12 / K12 / J12 / Y13 / W13 / J13 / D13 / C13 / W14 / K16 / J16 / Y17 / W17 / K17 / J17 / W19 / V19 / R19 / P19 / L19 / K19 / D19 / C19 / AF20 / AE20 / T20 / R20 / M20 / L20 / D21 / C22 / AC25 / Y25 / W25 / AC26 / R26 / L26 / A26 / G27 / B27 / AA26 / M28 / AG16 / AH21 | H2 / B18 / AC20 / AB5 / AB14 / AB20 / P2 / F22 / E2 / C22 / B4 / B7 / B10 / B15 | G1 / K1 / R1 / W1 / B2 / H4 / N4 / R4 / W4 / AB5 / A6 / D7 / Y7 / AE7 / A8 / G8 / D10 / G10 / L10 / N10 / Y10 / AC10 / C12 / D12 / A13 / D14 / AD14 / K15 / Y16 / L17 / N17 / R17 / D18 / D20 / G20 / E22 / AB22 / G23 / L23 / T23 / W23 / AF23 / B25 / K25 / U25 / AD25 | C1 / F1 / H2 / M2 / R2 / Y6 / AA7 / Y11 / AA16 / W20 / P20 / L21 / H20 / F20 / B14 / A13 / A7 | W15 / V16 / V15 / U16 / U15 / U14 / U11 / U9 / T16 / T15 / T14 / T13 / T12 / T11 / T10 / T9 / R15 / R14 / R11 / R10 / P17 / P15 / P14 / P13 / P12 / P11 / P10 / P8 / N16 / N15 / N14 / N13 / N12 / N11 / N10 / N9 / M16 / M13 / M11 / M10 / M9 / L17 / L13 / L10 / L8 / K15 / K14 / K11 / K10 / J16 / J15 / J14 / J13 / J12 / J11 / H16 / H14 / H11 |
| vdds_sram | SRAM LDOs | W16 | NA | U12 | NA | AA12 |
| vdds_mmc1 | MMC IO power domain for CMD, CLK, and DAT(0..3) | K25 | NA | N23 | NA | N24 |
| vdds_mmc1a | Power supply for MMC DAT [4..7] | P25 | NA | P23 | NA | H8 |
| cap_vdd_sram_mpu_iva | SRAM LDO capacitance for VDDRAM1 | V4 | NA | N9 | NA | U8 |
| cap_vdd_sram_core | SRAM LDO capacitance for VDDRAM2 | L21 | NA | K20 | NA | H17 |

2.5.9 System and Miscellaneous Terminals

Table 2-26. System and Miscellaneous Signals Description

| SIGNAL NAME | DESCRIPTION | TYPE ⁽¹⁾ | BALL BOTTOM (CBB Pkg.) | BALL TOP (CBB Pkg.) | BALL BOTTOM (CBC Pkg.) | BALL TOP (CBC Pkg.) | BALL BOTTOM (CUS Pkg.) |
|----------------------|---|---------------------|------------------------|---------------------|------------------------|---------------------|------------------------|
| sys_32k | 32-kHz clock input | I | AE25 | NA | AE20 | NA | AA16 |
| sys_xtalin | Main input clock. Oscillator input or LVCMOS at 19.2, 13, or 12 MHz. | I | AE17 | NA | AF19 | NA | AD15 |
| sys_xtalout | Output of oscillator | O | AF17 | NA | AF20 | NA | AD14 |
| sys_altdck | Alternate clock source selectable for GPTIMERS (maximum 54 MHz), USB (48 MHz), or NTSC/PAL (54 MHz) | I | J25 | NA | J23 | NA | A24 |
| sys_clkreq | Request from OMAP3530/25 device for system clock (open source type) | IO | AF25 | NA | W15 | NA | Y13 |
| sys_clkout1 | Configurable output clock1 | O | AG25 | NA | AE14 | NA | Y7 |
| sys_clkout2 | Configurable output clock2 | O | AE22 | NA | W11 | NA | AA6 |
| sys_boot0 | Boot configuration mode bit 0 | I | AH26 | NA | F3 | NA | AB12 |
| sys_boot1 | Boot configuration mode bit 1 | I | AG26 | NA | D3 | NA | AC16 |
| sys_boot2 | Boot configuration mode bit 2 | I | AE14 | NA | C3 | NA | AD17 |
| sys_boot3 | Boot configuration mode bit 3 | I | AF18 | NA | E3 | NA | AD18 |
| sys_boot4 | Boot configuration mode bit 4 | I | AF19 | NA | E4 | NA | AC17 |
| sys_boot5 | Boot configuration mode bit 5 | I | AE21 | NA | G3 | NA | AB16 |
| sys_boot6 | Boot configuration mode bit 6 | I | AF21 | NA | D4 | NA | AA15 |
| sys_nrespwrn | Power On Reset | I | AH25 | NA | V13 | NA | AA10 |
| sys_nreswarm | Warm Boot Reset (open drain output) | IOD | AF24 | NA | AD7 | NA | Y10 |
| sys_nirq | External FIQ input | I | AF26 | NA | V16 | NA | W16 |
| sys_nvmode1 | Indicates the voltage mode | O | AD26 | NA | AD15 | NA | Y16 |
| sys_nvmode2 | Indicates the voltage mode | O | AE26 | NA | W16 | NA | Y15 |
| sys_off_mode | Indicates the voltage mode | O | AF22 | NA | V12 | NA | AD23 |
| sys_ndmareq0 | External DMA request 0 (system expansion). Level (active low) or edge (falling) selectable. | I | U8 | NA | B6 | NA | D2 |
| sys_ndmareq1 | External DMA request 1 (system expansion). Level (active low) or edge (falling) selectable. | I | T8 / J8 | NA | B4 / C6 | NA | F4 / C2 |
| sys_ndmareq2 | External DMA request 2 (system expansion). Level (active low) or edge (falling) selectable. | I | L3 / R8 | NA | D1 / C4 | NA | H2 / G5 |
| sys_ndmareq3 | External DMA request 3 (system expansion). Level (active low) or edge (falling) selectable. | I | K3 / P8 | NA | D2 / B5 | NA | G2 / F3 |
| sys_secure_indicator | MSECURE transactions indicator | O | AG9 | NA | V2 | NA | AD5 |
| sys_drm_msecure | MSECURE output | O | AF9 | NA | AA4 | NA | AC4 |

(1) Type = Ball type for this specific function (I = Input, O = Output, Z = high-impedance, D = Open Drain, DS = Differential, A = Analog)

2.5.10 Feed-Through Balls (CBC and CBB Packages)

Feed-through pins represent a wire. That is, they do not connect to the silicon die, but rather just connect from the bottom ball to the top ball. The purpose of these balls is to allow for different PoP packages. [Table 2-27](#) and [Table 2-28](#) list the feed-through balls on the OMAP35x CBC and CBB packages, respectively.

Table 2-27. CBC Package Feed-Through Balls

| JEDEC 14x14mm, 0.65mm, 152ball | JEDEC DESCRIPTION ⁽¹⁾ | BALL TOP | BALL BOTTOM | FEED-THROUGH BALL NAME |
|--------------------------------|----------------------------------|----------|-------------|------------------------|
| NC | No Connect | A1 | A1 | pop_a1_a1 |
| d-vdd | DDR Supply | J1 | L1 | pop_j1_l1 |
| NC | No Connect | AA1 | AF1 | pop_aa1_af1 |

(1) For more details on the feedthrough pin connections, please refer to the PoP memory datasheet.

Table 2-27. CBC Package Feed-Through Balls (continued)

| | | | | |
|--------------|--|------|------|---------------|
| f-vdd | Flash Supply | N2 | T2 | pop_n2_t2 |
| f-vdd | Flash Supply | T2 | Y2 | pop_t2_y2 |
| NC | No Connect | W2 | AE2 | pop_w2_ae2 |
| NC | No Connect | Y2 | AF4 | pop_y2_af4 |
| f-vdd | Flash Supply | AA6 | AF5 | pop_aa6_af5 |
| f-vdd | Flash Supply | Y7 | AF8 | pop_y7_af8 |
| NC, Int | No Connect; Interrupt when using OneNAND POP | Y9 | AF10 | pop_y9_af10 |
| f-nbe0, cle0 | No Connect/CLE | AA10 | AF12 | pop_aa10_af12 |
| d-vdd | DDR Supply/ POP FLASH vpp supply | AA11 | AF13 | pop_aa11_af13 |
| d-tq | No Connect/ DDR die temperature sensor | AA12 | AF14 | pop_aa12_af14 |
| vss | Shared Ground | AA13 | AF15 | pop_aa13_af15 |
| d-vdd | DDR Supply | Y14 | AF17 | pop_y14_af17 |
| d-vddq | DDR Supply | AA14 | AF16 | pop_aa14_af16 |
| d-vdd | DDR Supply | B16 | A20 | pop_b16_a20 |
| vss | Shared Ground | Y17 | AF21 | pop_y17_af21 |
| d-vdd | DDR Supply | AA17 | AF18 | pop_aa17_af18 |
| vss | Shared Ground | Y19 | AF24 | pop_y19_af24 |
| d-vddq | DDR Supply | AA19 | AF22 | pop_aa19_af22 |
| NC | No Connect | A20 | A25 | pop_a20_a25 |
| NC | No Connect | Y20 | AE25 | pop_y20_ae25 |
| NC | No Connect | AA20 | AF25 | pop_aa20_af25 |
| NC | No Connect | A21 | A26 | pop_a21_a26 |
| NC | No Connect | B21 | B26 | pop_b21_b26 |
| d-vdd | DDR Supply | H21 | K26 | pop_h21_k26 |
| d-vdd | DDR Supply | P21 | U26 | pop_p21_u26 |
| NC | No Connect | Y21 | AE26 | pop_y21_ae26 |
| NC | No Connect | AA21 | AF26 | pop_aa21_af26 |

Table 2-28. CBB Package Feed-Through Balls

| JEDEC 12x12, 0.5mm, 168ball | JEDEC DESCRIPTION ⁽¹⁾ | BALL TOP | BALL BOTTOM | FEED-THROUGH BALL NAME |
|------------------------------------|---|-----------------|--------------------|-------------------------------|
| d-vdd | DDR Supply | A12 | A15 | pop_a12_a15 |
| d-vdd | DDR Supply | AA23 | AE28 | pop_aa23_ae28 |
| d-vdd | DDR Supply | H23 | AF28 | pop_h23_af28 |
| d-vdd | DDR Supply | K1 | J28 | pop_k1_j28 |
| d-vdd | DDR Supply | Y23 | M1 | pop_y23_m1 |
| f-vdd | Flash Supply | AA1 | AA1 | pop_aa1_aa1 |
| f-vdd | Flash Supply | AC8 | AF1 | pop_ac8_af1 |
| f-vdd | Flash Supply | AC13 | AH10 | pop_ac13_ah10 |
| f-vdd | Flash Supply | L1 | AH15 | pop_l1_ah15 |
| f-vdd | Flash Supply | U1 | N1 | pop_u1_n1 |
| f-vpp | Flash vpp supply | AC11 | AH13 | pop_ac11_ah13 |
| NC, int0 | No Connect/PoP OneNAND interrupt | AB9 | AG11 | pop_ab9_ag11 |
| NC, int1 | No Connect/PoP OneNAND interrupt | AC9 | AH11 | pop_ac9_ah11 |
| NC | No Connect | A1 | A1 | NA |
| NC | No Connect | A2 | A2 | pop_a2_a2 |
| NC | No Connect | A22 | A27 | pop_a22_a27 |
| NC | No Connect | A23 | A28 | pop_a23_a28 |

(1) For more details on the feedthrough pin connections, please refer to the PoP memory datasheet.

Table 2-28. CBB Package Feed-Through Balls (continued)

| | | | | |
|-------------|-----------------------|------|------|---------------|
| NC | No Connect | AB1 | AG1 | pop_ab1_ag1 |
| NC | No Connect | AB2 | NA | NA |
| NC | No Connect | AB22 | NA | NA |
| NC | No Connect | AB23 | AG28 | pop_ab23_ag28 |
| NC | No Connect | AC1 | AH1 | pop_ac1_ah1 |
| NC | No Connect | AC2 | AH2 | pop_ac2_ah2 |
| NC | No Connect | AC22 | AH27 | pop_ac22_ah27 |
| NC | No Connect | AC23 | AH28 | pop_ac23_ah28 |
| NC | No Connect | B1 | B1 | NA |
| NC | No Connect | B2 | NA | NA |
| NC | No Connect | B22 | NA | NA |
| NC | No Connect | B23 | B28 | pop_b23_b28 |
| f-rst#, rp# | Flash reset | AB11 | AG13 | pop_ab11_ag13 |
| d-tq | DDR temperature alert | AC14 | AH16 | pop_ac14_ah16 |
| vss | Shared Ground | AA2 | AA2 | pop_aa2_aa2 |
| vss | Shared Ground | U2 | AF2 | pop_u2_af2 |
| vss | Shared Ground | AA22 | AF27 | pop_aa22_af27 |
| vss | Shared Ground | AB8 | AG10 | pop_ab8_ag10 |
| vss | Shared Ground | AB13 | AG15 | pop_ab13_ag15 |
| vss | Shared Ground | B12 | B15 | pop_b12_b15 |
| vss | Shared Ground | H22 | J27 | pop_h22_j27 |
| vss | Shared Ground | K2 | M2 | pop_k2_m2 |
| vss | Shared Ground | K22 | M26 | pop_k22_m26 |
| vss | Shared Ground | L2 | N2 | pop_l2_n2 |

3 ELECTRICAL CHARACTERISTICS

3.1 Power Domains

The OMAP3530/25 device integrates enhanced features that dynamically adapt energy consumption according to application needs and performance requirements.

The OMAP3530/25 device includes an enhanced power-management scheme based on:

- Nine independent functional voltage domains on chip partitioning
- Multiple voltage domains
- Voltage scaling support
- Enhanced memory retention support
- Optimized device off mode
- Centralized management of power, reset, and clock

The external power supplies of OMAP3530/25 are:

- vdd_mpu_iva for the ARM and IVA2.2 processors
- vdd_core for macros
- vdds for IO macros
- vdds_mem for memory macros
- vdds_sram for SRAM LDOs
- vdds_dpll_dll for DLL IO
- vdds_dpll_per for peripheral DPLLs
- vdds_wkup_bg for wakeup LDO and VDDA (2 LDOs: SRAM and BandGap)
- vdda_dac for video DAC
- vdds_mmc1 and vdds_mmc1a for MMC IO
- The supply voltages are detailed in [Table 3-3](#).

[Figure 3-1](#) illustrates the power domains:

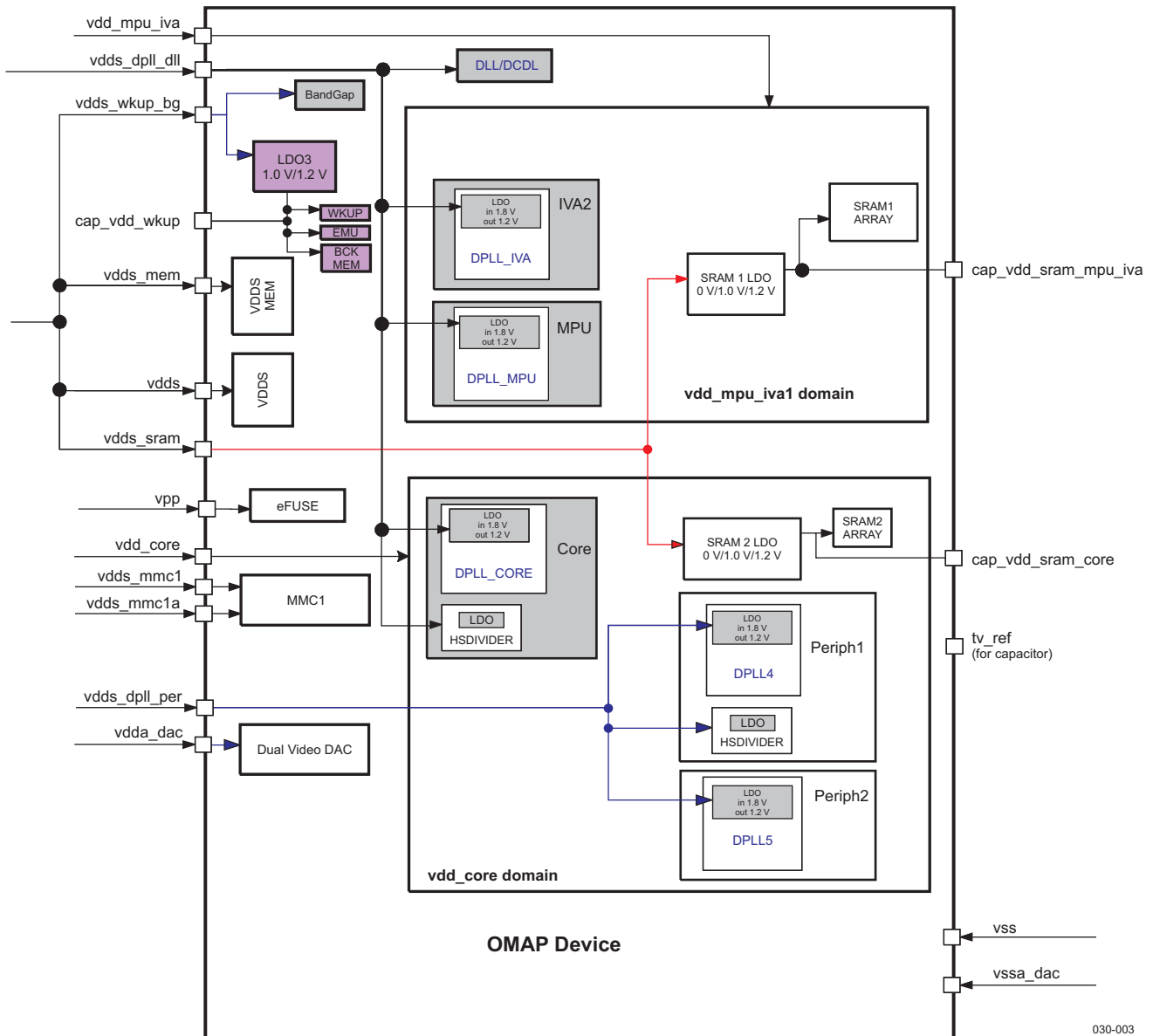

030-003

Figure 3-1. OMAP3530/25 Power Domains

This power domain segmentation switches off (or places in retention state) domains that are unused while keeping others active. This implementation is based on internal switches that independently control each power domain.

A power domain regular logic is attached to one of the device V_{DD} supplies through a primary domain switch. When the primary switch is open, most of the logic supply is off, resulting in a low-leakage state of the domain. Embedded switches are implemented for all power domains except the wake-up domain. This allows the domain to be powered off, if not being used, to give maximum power savings. For more information, see the PRCM chapter of the *OMAP35x Technical Reference Manual (TRM)* [literature number [SPRUFA5](#)].

All domain output signals at the interface between power domains are connected through isolation latch cells. These cells ensure a proper electrical isolation between the domains and an appropriate interface state at the domain boundaries.

3.2 Absolute Maximum Ratings

The following table specifies the absolute maximum ratings over the operating junction temperature range of OMAP commercial and extended temperature devices. Stresses beyond those listed under absolute maximum ratings may cause permanent damage to the device. These are stress ratings only and functional operation of the device at these or any other conditions beyond those indicated under recommended operating conditions is not implied. Exposure to absolute-maximum-rated conditions for extended periods may affect device reliability.

Notes:

- Logic functions and parameter values are not assured out of the range specified in the recommended operating conditions.
- The OMAP3530/25 device adheres to EIA/JESD22–A114, Electrostatic Discharge (ESD) Sensitivity Testing Human Body Model (HBM). Minimum pass level for HBM is ± 1 kV.

Table 3-1. Absolute Maximum Ratings Over Operating Junction Temperature Range

| PARAMETER | | | MIN | MAX | UNIT | |
|--------------------------------|---|--|---|----------------------------|---------------------|---|
| vdd_mpu_iva vdd_core | Supply voltage range for core macros | | –0.5 | 1.6 | V | |
| vdds vdds_mem | Second supply voltage range for 1.8-V I/O macros | | –0.5 | 2.25 | V | |
| vdds_mmc1 | Supply voltage range for MMC1 CMD, CLK and DAT[3:0] and for memory stick I/Os | 1.8-V mode | –0.5 | 2.45 | V | |
| | | 3.0-V mode | –0.5 | 3.50 | | |
| vdds_vdds_mmc1a | Second supply voltage range for MMC1 DAT[7:4] | 1.8-V mode | –0.5 | 2.45 | V | |
| | | 3.0-V mode | –0.5 | 3.50 | | |
| vdds_dpll_dll vdds_dpll_per | Supply voltage for DLL DPLL Supply voltage for Per DPLL | | –0.5 | 2.10 | V | |
| vdds_sram vdds_wkup_bg | Supply voltage for SRAM LDOs Supply voltage for wakeup LDO and VDDA (2 LDOs SRAM and BG) | | –0.5 | 2.25 | V | |
| V _{PAD} | Voltage range at PAD | MMC1, MS (Balls N28, M27, N27, N26, N25, P28) MMC1 (Balls P27, P26, R27, R25) | Supply voltage range for 1.8-V I/Os | –0.54 ⁽¹⁾ | 2.34 ⁽¹⁾ | |
| | | | Supply voltage range for 3.0-V I/Os | –0.45 ⁽²⁾ | 3.45 ⁽²⁾ | |
| | | I2C1, I2C2, I2C3, I2C4 (Balls K21, J21, AF15, AE15, AF14, AG14, AD26, AE26) | –0.63 ⁽¹⁾ | 2.73 ⁽¹⁾ | | |
| | | Crystal (xtalin/xtalout) (Balls AE17, AF17) | –0.5 | 2.71 | | |
| | | Other balls | –0.5 | vddsx ⁽³⁾ + 0.5 | | |
| vdda_dac | Supply voltage range for analog macros | | –0.5 | 2.43 | V | |
| V _{ESD} | ESD stress voltage ⁽⁴⁾ | HBM (human body model) ⁽⁵⁾ | vdds_MMC1a, mmc1_dat[7-4] (CBB pkg only) ⁽⁶⁾ | | 500 | V |
| | | | Other pins | | 1000 | |
| | | CDM (charged device model) ⁽⁷⁾ | MMC1 signals (CBB pkg only) ⁽⁶⁾ | | 300 | |
| | | | Other pins | | 500 | |
| I _{IOI} | Current-pulse injection on each I/O pin ⁽⁸⁾ | | | 200 | mA | |
| I _{clamp} | Clamp current for an input or output | | –20 | 20 | mA | |
| T _{stg} | Storage temperature range ⁽⁹⁾ | | –65 | 150 | °C | |

(1) For a maximum time of 30% time period.

(2) For a maximum time of 15% time period.

(3) Depending on ball, vddsx can be vdds_mem or vdds.

(4) Electrostatic discharge (ESD) to measure device sensitivity/immunity to damage caused by electrostatic discharges into the device.

(5) JEDEC JESD22–A114F

(6) Corresponding signals: mmc1_dat0, mmc1_dat1, mmc1_dat2, mmc1_dat3, mmc1_dat4, mmc1_dat5, mmc1_dat6, mmc1_dat7, mmc1_clk, mmc1_cmd and vdds_mmc1 (CBB pkg only).

(7) JEDEC JESD22–C101D

(8) Each device is tested with I/O pin injection of 200 mA with a stress voltage of 1.5 times maximum vdd at room temperature.

(9) These temperatures extreme do not simulate actual operating conditions but exaggerate any faults that might exist.

This section includes the maximum power consumption for each power domain (core, IVA2, etc.). [Table 3-2](#) summarizes the power consumption at the ball level.

Table 3-2. Estimated Maximum Power Consumption At Ball Level

| PARAMETER | | MAX (T = 90°C) | MAX (T = 105°C) | UNIT | |
|----------------|---|--|---------------------|------|----|
| Signal | Description | | | | |
| vdd_mpu_iva | Processors ⁽¹⁾ | OMAP3530/25 (SmartReflex™ Enabled- OPP5) | 994 | 1051 | mA |
| | | OMAP3530/25 (SmartReflex™ Disabled - OPP5) | 1236 | 1317 | mA |
| | | OMAP3530 (SmartReflex™ Enabled - OPP6) | 1177 | 1233 | mA |
| | | OMAP3530 (SmartReflex™ Disabled - OPP6) | 1457 | 1538 | mA |
| vdd_core | Core ⁽¹⁾ | OMAP3530 (SmartReflex™ Enabled - OPP5/6) | 439 | 489 | mA |
| | | OMAP3530 (SmartReflex™ Disabled - OPP5/6) | 539 | 609 | mA |
| | | OMAP3525 (SmartReflex™ Enabled - OPP5) | 353 | 403 | mA |
| | | OMAP3525(SmartReflex™ Disabled - OPP5) | 438 | 507 | mA |
| vdda_dac | Video DAC | 65 | 65 | mA | |
| vdss_dppll_dll | DLL + DPLL MPU, DSP, and core | 25 | 25 | mA | |
| vdss_dppll_per | DPLL peripheral 1 and peripheral 2 | 15 | 15 | mA | |
| vdss_sram | Processors and core LDO (LDO1 and LDO2) | 41 | 41 | mA | |
| vdss_wkup_bg | Bandgap, wakeup + LDO, EMU off | 6 | 6 | mA | |
| vdss_mem | Standard I/Os (SDRC+GPMC) | 37 | 37 | mA | |
| vdss | Standard I/Os (all excluding SDRC and GPMC) | 63 | 63 | mA | |
| vdss_mmc1 | MMC I/O ⁽²⁾ | 20 | 20 | mA | |
| vdss_mmc1a | Power supply for MMC IO [DAT4 – DAT7] | 2 | 2 | mA | |
| vpp | eFuse | 50 | 50 | mA | |

(1) OPP6 is only supported on high-speed grade OMAP3530 devices.

(2) MMC card and I/O card are not included.

3.3 Recommended Operating Conditions

All OMAP3530/25 modules are used under the operating conditions contained in [Table 3-3](#).

Note:

To avoid significant device degradation for commercial temperature OMAP3530/OMAP3525 devices ($0^{\circ}\text{C} \leq T_j \leq 90^{\circ}\text{C}$), the device power-on hours (POH) must be limited to one of the following:

- 100K total POH when operating across all OPPs and keeping the time spent at OPP5-OPP6 to less than 23K POH.
- 50K total POH when operating at OPP5 - OPP6.
- 44K total POH with *no restrictions* to the proportion of these POH at operating points OPP1 - OPP6.

To avoid significant device degradation for extended temperature OMAP3530A/OMAP3525A devices ($-40^{\circ}\text{C} \leq T_j \leq 105^{\circ}\text{C}$), the following restrictions apply:

- OPP5 and OPP6 are not supported.*
- The total device POH must be limited to less than 50K.*

*If an extended temperature device is operated such that T_j never exceeds 90°C ($-40^{\circ}\text{C} \leq T_j \leq 90^{\circ}\text{C}$) then the OPP POH limits for commercial devices indicated above apply.

Note: Logic functions and parameter values are not assured out of the range specified in the recommended operating conditions.

Table 3-3. Recommended Operating Conditions

| PARAMETER | DESCRIPTION | | MIN | NOM | MAX | UNIT |
|---|---|---|--|-------|--|------|
| V _{DD1} (vdd_mpu_iva), SmartReflex Disabled | OMAP processor logic supply | OPP6: Overdrive ⁽¹⁾ | V _{DD1NOM} - (0.05*V _{DD1NOM}) | 1.35 | V _{DD1NOM} + (0.05*V _{DD1NOM}) | V |
| | | OPP5: Overdrive | V _{DD1NOM} - (0.05*V _{DD1NOM}) | 1.35 | V _{DD1NOM} + (0.05*V _{DD1NOM}) | V |
| | | OPP4: Mid-Overdrive | V _{DD1NOM} - (0.05*V _{DD1NOM}) | 1.27 | V _{DD1NOM} + (0.05*V _{DD1NOM}) | V |
| | | OPP3: Nominal | V _{DD1NOM} - (0.05*V _{DD1NOM}) | 1.20 | V _{DD1NOM} + (0.05*V _{DD1NOM}) | V |
| | | OPP2: Low-Power | V _{DD1NOM} - (0.05*V _{DD1NOM}) | 1.06 | V _{DD1NOM} + (0.05*V _{DD1NOM}) | V |
| | | OPP1: Ultra Low-Power ⁽²⁾ | V _{DD1NOM} - (0.05*V _{DD1NOM}) | 0.985 | V _{DD1NOM} + (0.05*V _{DD1NOM}) | V |
| V _{DD2} (vdd_core) SmartReflex Disabled | OMAP core logic supply ⁽³⁾ | OPP3: Nominal | V _{DD2NOM} - (0.05*V _{DD2NOM}) | 1.15 | V _{DD2NOM} + (0.05*V _{DD2NOM}) | V |
| | | OPP2: Low-Power | V _{DD2NOM} - (0.05*V _{DD2NOM}) | 1.06 | V _{DD2NOM} + (0.05*V _{DD2NOM}) | V |
| | | OPP1: Ultra Low-Power ⁽²⁾ | V _{DD2NOM} - (0.05*V _{DD2NOM}) | 0.985 | V _{DD2NOM} + (0.05*V _{DD2NOM}) | V |
| vdds | Supply voltage for I/O macros | | 1.71 | 1.8 | 1.91 | V |
| | Noise (peak-peak) | | | | 90 | mVpp |
| vdds_mem | Supply voltage for memory I/O macros | | 1.71 | 1.8 | 1.89 | V |
| | Noise (peak-peak) | | | | 90 | mVpp |
| vdds_mmc1 | Supply voltage range for MMC1 CMD, CLK and DAT[3:0] and for memory stick I/Os | 1.8-V mode | 1.71 | 1.8 | 1.89 | V |
| | | 3.0-V mode | 2.7 | 3.0 | 3.3 | V |
| vdds_mmc1a | Second supply voltage range for MMC1 DAT[7:4] | 1.8-V mode | 1.71 | 1.8 | 1.89 | V |
| | | 3.0-V mode | 2.7 | 3.0 | 3.3 | V |
| vdds_wkup_bg | Wakeup LDO | | 1.71 | 1.8 | 1.89 | V |

(1) OPP6 is only supported on high-speed grade OMAP3530/25 devices.

(2) Cannot boot in OPP1. If OPP1 is desired, boot in higher OPP then switch to OPP1.

(3) Core logic includes interconnect, graphics processor, and peripherals.

Table 3-3. Recommended Operating Conditions (continued)

| PARAMETER | DESCRIPTION | | MIN | NOM | MAX | UNIT |
|--------------------|---|--|------|-----|------|------|
| | Noise (peak-peak) | | | | 50 | mVpp |
| vdda_dac | Analog supply voltage for video DAC | | 1.71 | 1.8 | 1.89 | V |
| | Noise (peak-peak) | For a frequency of 0 to 100 kHz (For a frequency < 100 kHz, decreases 20dB / sec) | | | 30 | mVpp |
| vdds_sram | SRAM LDOs | | 1.71 | 1.8 | 1.89 | V |
| | Noise (peak-peak) | | | | 50 | mVpp |
| vdds_dppll_per | Peripherals DPLLs power supply | | 1.71 | 1.8 | 1.89 | V |
| | Noise (peak-peak) | | | | 36 | mVpp |
| vdds_dppll_dll | Supply voltage for DPLLs I/Os | | 1.71 | 1.8 | 1.89 | V |
| | Noise (peak-peak) | | | | 30 | mVpp |
| vpp ⁽⁴⁾ | eFuse programming | | | | | V |
| vss | Ground | | 0 | 0 | 0 | V |
| vssa_dac | Dedicated ground for DAC | | 0 | 0 | 0 | V |
| T _a | Operating free air temperature range | Commercial Temperature | 0 | – | 70 | °C |
| | | Extended Temperature | -40 | - | 85 | |
| T _j | Operating junction temperature ⁽⁵⁾ | Commercial Temperature | 0 | – | 90 | °C |
| | | Extended Temperature | -40 | - | 105 | |

(4) It is recommended not to connect this pin. It is just used for eFuse programming on package unit.

(5) For proper device operation, T_j must be within the specified range.

3.4 DC Electrical Characteristics

Table 3-4 summarizes the dc electrical characteristics.

Table 3-4. DC Electrical Characteristics

| PARAMETER | | MIN | NOM | MAX | UNIT |
|--|---|-----------------------------|-----------------------------|-----------------------------|-------------------|
| LVC MOS Pin Buffers - CBB: N28, M27, N27, N26, N25, P28, P27, P26, R27, R25/ CBC: N19, L18, M19, M18, K18, N20, M20, P17, P18, P19/ CUS: M23, L23, M22, M21, M20, N23 | | | | | |
| V _{IH} | High-level input voltage | vdds ⁽¹⁾ = 1.8 V | 0.65 × vdds ⁽¹⁾ | | V |
| | | vdds ⁽¹⁾ = 3.0 V | 0.625 × vdds ⁽¹⁾ | vdds + 0.3 | |
| V _{IL} | Low-level input voltage | vdds ⁽¹⁾ = 1.8 V | −0.3 | | V |
| | | vdds ⁽¹⁾ = 3.0 V | −0.3 | 0.35 × vdds | |
| V _{OH} | High-level output voltage ⁽²⁾ | vdds ⁽¹⁾ = 1.8 V | vdds ⁽¹⁾ − 0.2 | | V |
| | | vdds ⁽¹⁾ = 3.0 V | 0.75 × vdds ⁽¹⁾ | | |
| V _{OL} | Low-level output voltage ⁽²⁾ | vdds ⁽¹⁾ = 1.8 V | | 0.2 | V |
| | | vdds ⁽¹⁾ = 3.0 V | | 0.125 × vdds ⁽¹⁾ | |
| t _T | Input transition time (rise time, t _R or fall time, t _F evaluated between 10% and 90% at PAD) | Normal Mode | | 10 | ns |
| | | High-Speed Mode | | 3 | |
| LVDS/CMOS Pin Buffers - CBB: AG19, AH19, AG18, AH18, AG17, AH17/ CBC: AE16, AE15, AD17, AE18, AD16, AE17/ CUS: AB18, AC18 | | | | | |
| Low-Power Receiver (LP-RX) | | | | | |
| V _{IL} | Low-level input threshold | | | 500 | mV |
| V _{IH} | High-level input threshold | 800 | | | mV |
| V _{HYS} | Input hysteresis | 25 | | | mV |
| Ultralow-Power Receiver (ULP-RX) | | | | | |
| V _{IL-ULPM} | Low-level input threshold, ULPM | | | 300 | mV |
| V _{IH} | High-level input threshold | 880 | | | mV |
| High-Speed Receiver (HS-RX) | | | | | |
| V _{IDTH} | Differential input high threshold | 70 | | | mV |
| V _{IDTL} | Differential input low threshold | | | −70 | mV |
| V _{IDMAX} | Maximum differential input voltage | | | 270 | mV |
| V _{ILHS} | Single-ended input low voltage | −40 | | | mV |
| V _{IHHS} | Single-ended input high voltage | | | 460 | mV |
| V _{CMRXDC} | Common-mode voltage | 70 | | 330 | mV |
| LVDS/CMOS Pin Buffers - CBB: K28, L28, K27, L27/ CBC: P25, P26, N25, N26 / CUS: L24, K24, J23, K23 | | | | | |
| V _{CM} | Input common mode voltage range | 600 | 900 | 1200 | mV |
| V _{OS} | Receiver Input dc offset | −20 | | 20 | mV |
| V _{ID} | Receiver input differential amplitude | 70 | 100 | 200 | mV ⁽³⁾ |
| t _T | Input transition time (rise time, t _R or fall time, t _F evaluated between 10% and 90% at PAD) | 267 | | 533 | ps |
| LVDS/CMOS Pin Buffers - CBB: AG22, AH22, AG23, AH23, AG24, AH24/ CBC: AE21, AE22, AE23, AE24, AD23, AD24 / CUS: AC19, AB19, AD20, AC20, AD21, AC21 | | | | | |
| High-Speed Transceiver (HS-TX) | | | | | |
| V _{OHS} | HS output high voltage | | | 360 | mV |
| V _{OD} | HS transmit differential voltage | 140 | 200 | 270 | mV |
| V _{CMTX} | HS transmit static common mode voltage | 150 | 200 | 250 | mV |
| Low-Power Transceiver (LP-TX) | | | | | |

(1) This global value may be overridden on a per interface basis if another value is explicitly defined for that interface (for example, I²C).

(2) With 100 μA sink / source current at vdds_{xmin}.

(3) Corresponds to peak-to-peak values: minimum = 140 mV_{pp}; nominal = 200 mV_{pp}; maximum = 400 mV_{pp}.

Table 3-4. DC Electrical Characteristics (continued)

| PARAMETER | | MIN | NOM | MAX | UNIT |
|--|---|--|-------------------------|-------------------------|------|
| V _{OL} | Thevenin output low level | -50 | | 50 | mV |
| V _{OH} | Thevenin output high level | 1.1 | 1.2 | 1.3 | V |
| Low-Power Receiver (LP-RX) | | | | | |
| V _{IL} | Low-level input threshold | | | 550 | mV |
| V _{IH} | High-level input threshold | 880 | | | mV |
| V _{HYST} | Input hysteresis | 25 | | | mV |
| Ultralow-Power Receiver (ULP-RX) | | | | | |
| V _{IL-ULPS} | Low-level input threshold, ULPM | | | 300 | mV |
| V _{IH} | High-level input threshold | 880 | | | mV |
| subLVDS/CMOS Pin Buffers - CBB: AA27, AA28, AB27, AB28, AD27, AD28, AC28, AC27/ CBC: AC26, AD26, AA25, Y25, AA26, AB26, AC25, AB25/ CUS: V22, W22, Y22, AB22, AC23, AC22, W21, V21 | | | | | |
| V _{od} | Differential voltage range @ R _L = 100 Ω | 100 | 150 | 200 | mV |
| V _{ocm} | Common mode voltage range | 0.8 | 0.9 | 1 | V |
| t _T | Input transition time (V _{od} rise time, t _R or V _{od} fall time, t _F evaluated between 20% and 80% at PAD) | 200 | | 500 | ps |
| Standard LVCMOS Pin Buffers | | | | | |
| V _{IH} ⁽⁴⁾ | High-level input voltage (Standard LVCMOS) | 0.65 × v _{dds} | | v _{dds} + 0.3 | V |
| V _{IL} ⁽⁴⁾ | Low-level input voltage (Standard LVCMOS) | - 0.3 | | 0.35 × v _{dds} | V |
| V _{HYS} | Hysteresis voltage at an input ⁽⁵⁾ | | 0.1 | | V |
| V _{OH} | High-level output voltage, driver enabled, pullup or pulldown disabled | I _O = I _{OH} or I _O = -2 mA | v _{dds} - 0.45 | | V |
| | | I _O = I _{OH} < -2 mA | v _{dds} - 0.40 | | |
| V _{OL} | Low-level output voltage with , driver enabled, pullup or pulldown disabled | I _O = I _{OL} or I _O = 2 mA | | 0.45 | V |
| | | I _O = I _{OL} < 2 mA | | 0.40 | |
| t _T | Input transition time (rise time, t _R or fall time, t _F evaluated between 10% and 90% at PAD) | 0 | | 10 ⁽¹⁾ | ns |
| I _I | Input current with V _I = V _I max | -1 | | 1 | μA |
| I _{OZ} | Off-state output current for output in high impedance with driver only, driver disabled | -20 | | 20 | μA |
| | Off-state output current for output in high impedance with driver/receiver/pullup only, driver disabled, pullup not inhibited | | -100 | | |
| | Off-state output current for output in high impedance with driver/receiver/pulldown only, driver disabled, pulldown not inhibited | | 100 | | |
| I _Z | Total leakage current through the PAD connection of a driver/receiver combination that may include a pullup or pulldown. The driver output is disabled and the pullup or pulldown is inhibited. | - 20 | | 20 | μA |
| LVCMOS Open-Drain Pin Buffers Dedicated to I2C IOs - CBB: K21, J21, AF14, AG14, AF15, AE15, AD26, AE26/ CBC: J25, J24, C2, C1, AB4, AC4, AD15, W16, A21, C21/ CUS: K20, K21, AC13, AC12, AC15, AC14, Y16, Y15 | | | | | |
| V _{IH} | High level input voltage | 0.7 × v _{dds} | | v _{dds} + 0.5 | V |
| V _{IL} | Low level input voltage | - 0.5 | | 0.3 × v _{dds} | V |
| V _{OL} | Low-level output voltage open-drain at 3-mA sink current | 0 | | 0.2 × v _{dds} | V |
| I _I | Input current at each I/O pin with an input voltage between 0.1 × v _{dds} to 0.9 × v _{dds} | - 10 | | 10 | μA |
| C _I | Capacitance for each I/O pin | | | 10 | pF |

(4) V_{IH}/V_{IL} (Standard LVCMOS) parameters are applicable for sys_altclk input clocks.

(5) V_{hys} is the magnitude of the difference between the positive-going threshold voltage V_{T+} and the negative-going voltage V_{T-}.

Table 3-4. DC Electrical Characteristics (continued)

| PARAMETER | | MIN | NOM | MAX | UNIT | | |
|--|---|-------------------------|---|------------------------|------|----|----|
| T _{OF} | Output fall time from V _{IHmin} to V _{ILmax} with a bus capacitance C _B from 10 pF to 400 pF | Fast mode | 20 + 0.1C _B | | 250 | ns | |
| | | Standard mode | | | 250 | | |
| | Output fall time with a capacitive load from 10 pF to 100 pF at 3-mA sink current | High-speed mode | 10 | | 40 | | |
| | | | Output fall time with a capacitive load of 400 pF at 3-mA sink current | 20 | | | 80 |
| | | | Output fall time with a capacitive load of 40 pF (for CBUS compatibility) | | | | 20 |
| LVC MOS Open-Drain Pin Buffers Dedicated in GPIO mode - CBB: AF15, AE15, AF14, AG14, AD26, AE26 / CBC: C2, C1, AB4, AC4, AD15, W16, A21, C21/ CUS: AC15, AC14, AC13, AC12, Y16, Y15 | | | | | | | |
| V _{IH} | High-level input voltage | 0.7 x v _{dds} | | v _{dds} + 0.5 | V | | |
| V _{IL} | Low-level input voltage | - 0.5 | | 0.3 x v _{dds} | V | | |
| V _{OH} | High-level output voltage at 4-mA sink current | v _{dds} - 0.45 | | | V | | |
| V _{OL} | Low-level output voltage at 4-mA sink current | | | 0.45 | V | | |

3.5 Core Voltage Decoupling

For module performance, decoupling capacitors are required to suppress the switching noise generated by high frequency and to stabilize the supply voltage. A decoupling capacitor is most effective when it is close to the device because this minimizes the inductance of the circuit board wiring and interconnects.

Table 3-5 summarizes the power supplies decoupling characteristics.

Table 3-5. Core Voltage Decoupling Characteristics

| PARAMETER | MIN | TYP | MAX | UNIT |
|-----------------------------|-----|-----|-----|------|
| Cvdd_mpu_iva ⁽¹⁾ | 50 | 100 | 120 | nF |
| Cvdd_core ⁽¹⁾ | 50 | 100 | 120 | nF |
| Cvdds_sram | | 100 | | nF |
| Ccap_vdd_sram_mpu_iva | 0.7 | 1.0 | 1.3 | μF |
| Ccap_vdd_sram_core | 0.7 | 1.0 | 1.3 | μF |
| Ccap_vdd_wkup | 0.7 | 1.0 | 1.3 | μF |
| Cvdds_wkup_bg | | 100 | | nF |
| Cvdds_dpII_dll | | 100 | | nF |
| Cvdds_dpII_per | | 100 | | nF |
| Cvdda_dac | | 100 | | nF |
| Ccap_vdd_d | 100 | | 200 | nF |
| Cvdds_mmc1 | | 100 | | nF |
| Cvdds_mmc1a | | 100 | | nF |
| Cvdds | | 100 | | nF |
| Cvdds_mem | | 100 | | nF |

(1) 1 capacitor per 2 to 4 balls

illustrates an example of power supply decoupling.

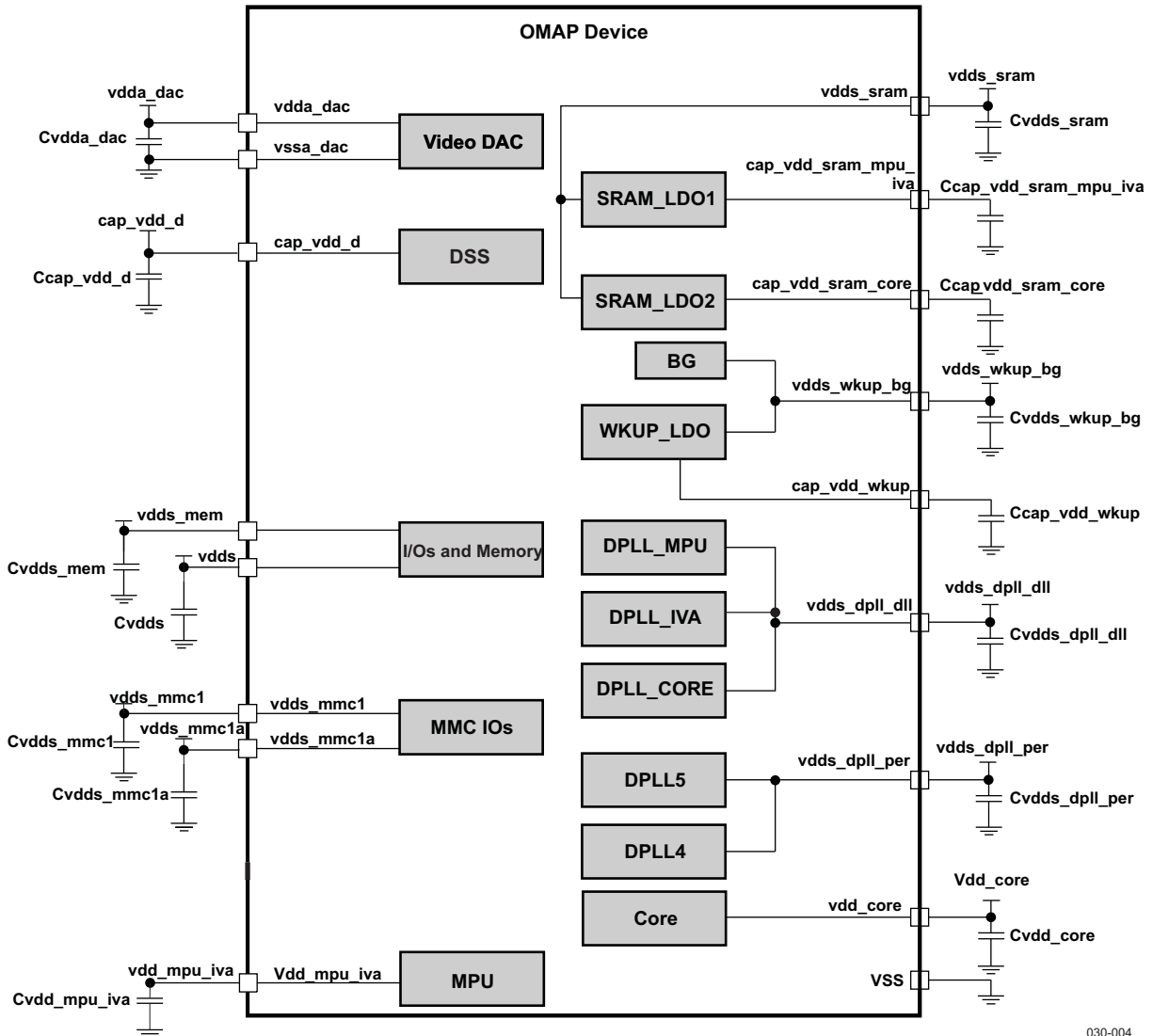

030-004

- A. On the CBC package, signals "vdds" and "vdds_mem" are combined with "vdds".
- B. Signals "vdds" and "vdds_mem" are separate on the CBB and CUS packages.

Figure 3-2. Power Supply Decoupling

3.6 Power-up and Power-down

This section provides the timing requirements for the OMAP3530/25 hardware signals.

3.6.1 Power-up Sequence

The following steps give an example of power-up sequence supported by the OMAP3530/25 device.

1. vdds and vdds_mem are ramped ensuring a level on the IO domain and sys_nrespwron must be low. At the same time, vdds_sram and vdds_wkup_bg can also be ramped.
2. Once vdds_wkup_bg rail is stabilized, vdd_core can be ramped.
3. Once vdd_core is stabilized, then vdd_mpu_iva can be ramped.
4. vdds_dpll_dll and vdds_dpll_per rails can be ramped at any time during the above sequence.
5. sys_nrespwron can be released as soon as the vdds_pll_dll rail is stabilized, and sys_xtalin and sys_32k clocks are stabilized.
6. During the whole sequence above, sys_nreswarm is held low by OMAP3530/25. sys_nreswarm is released after the eFuse check has been performed; that is, after sys_nrespwron is released.
7. The other power supplies can then be turned on upon software request.

shows the power-up sequence.

Notes:

- If an external square clock is provided, it could be started after sys_nrespwron release provided it is clean: no glitch, stable frequency, and duty cycle.
- Higher voltage can be used. OPP voltage values may change following the silicon characterization result.

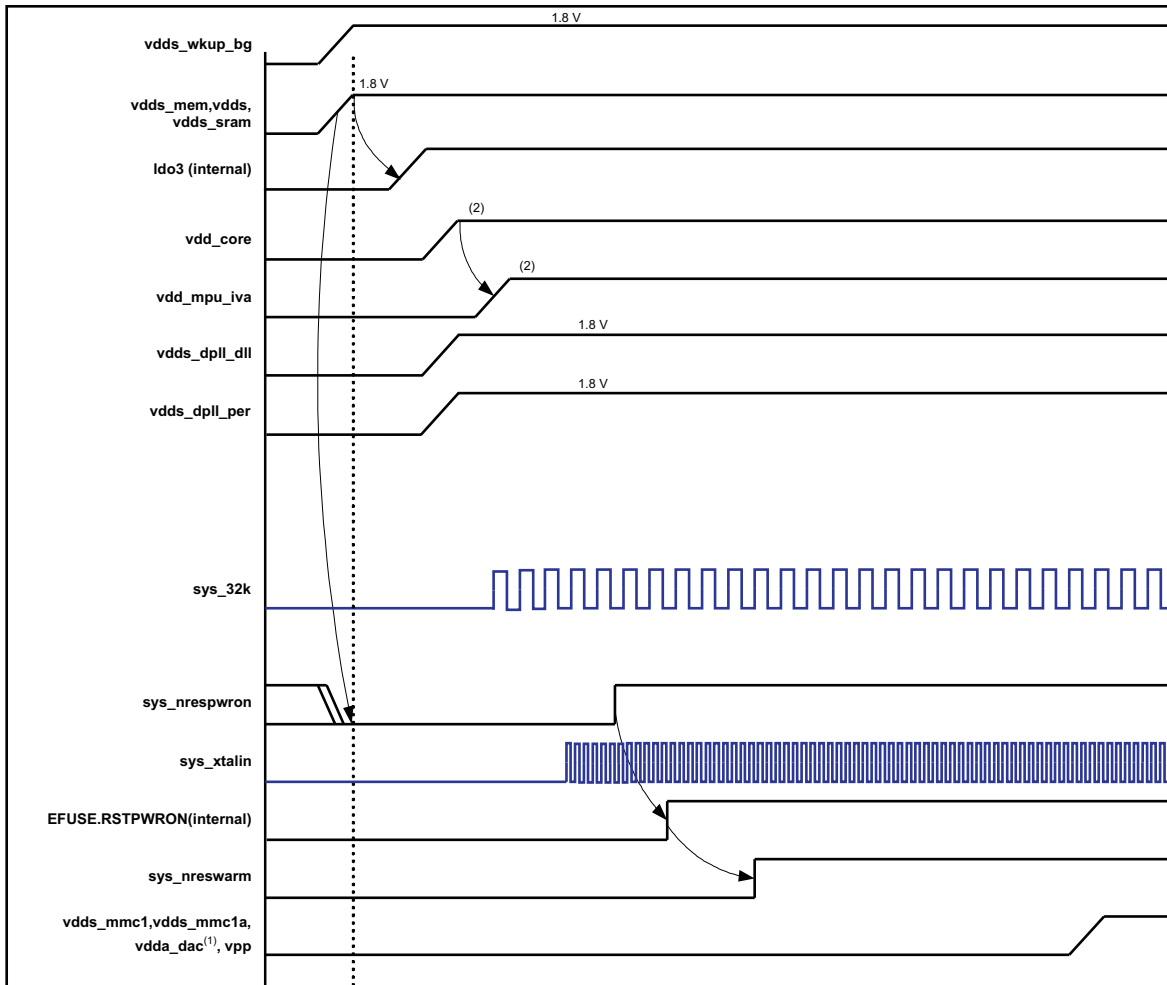

030-005

Figure 3-3. Power-up Sequence

3.6.2 Power-down Sequence

The following steps give an example of the power-down sequence supported by the OMAP3530/25 device.

1. Reset OMAP3530/25 device.
2. Stop all signals driven to OMAP3530/25 balls.
3. Option 1: Power down all domains simultaneously.
4. Option 2: If all domains cannot be powered down simultaneously, follow the below sequence:
 - a. Power off all complex I/O domains (vdds_mmc1, vdds_mmc1a, vdda_dac)
 - b. Power off all core domains (vdd_core, vdd_mpu_iva)
 - c. Power off all PLL domains (vdds_dp11_dll, vdds_dp11_per)
 - d. Power off all SRAM LDOs (vdds_sram)
 - e. Power off all reference domains (vdds_wkup_bg)
 - f. Power off all standard I/O domains (vdds, vdds_mem)

The OMAP3530/25 device proceeds with the power-down sequence shown in .

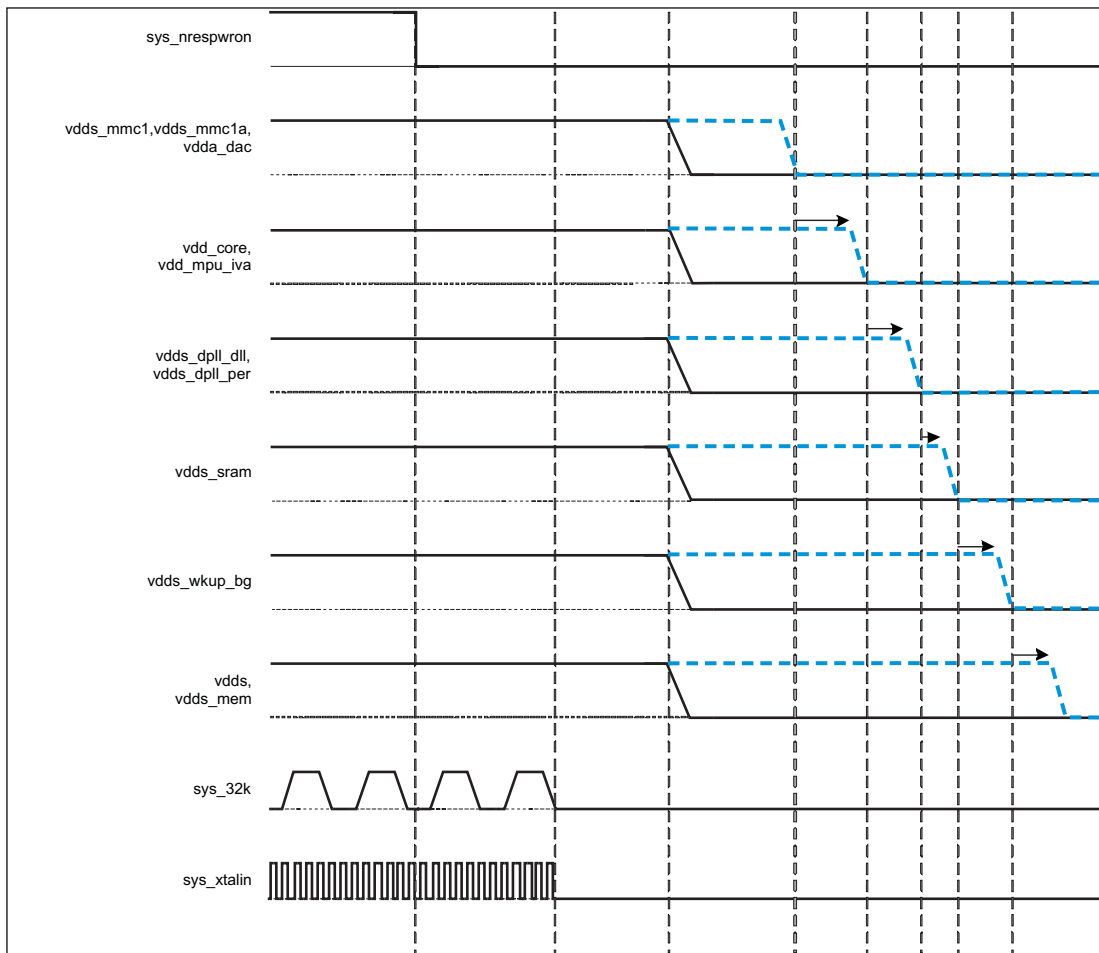

034-009

Figure 3-4. Power-down Sequence

4 CLOCK SPECIFICATIONS

The OMAP3530/25 device has three external input clocks, a low frequency (sys_32k), a high frequency (sys_xtalin), and an optional (sys_altclk). The OMAP3530/25 device has two configurable output clocks, sys_clkout1 and sys_clkout2.

Figure 4-1 shows the interface to the external clock sources and clock outputs.

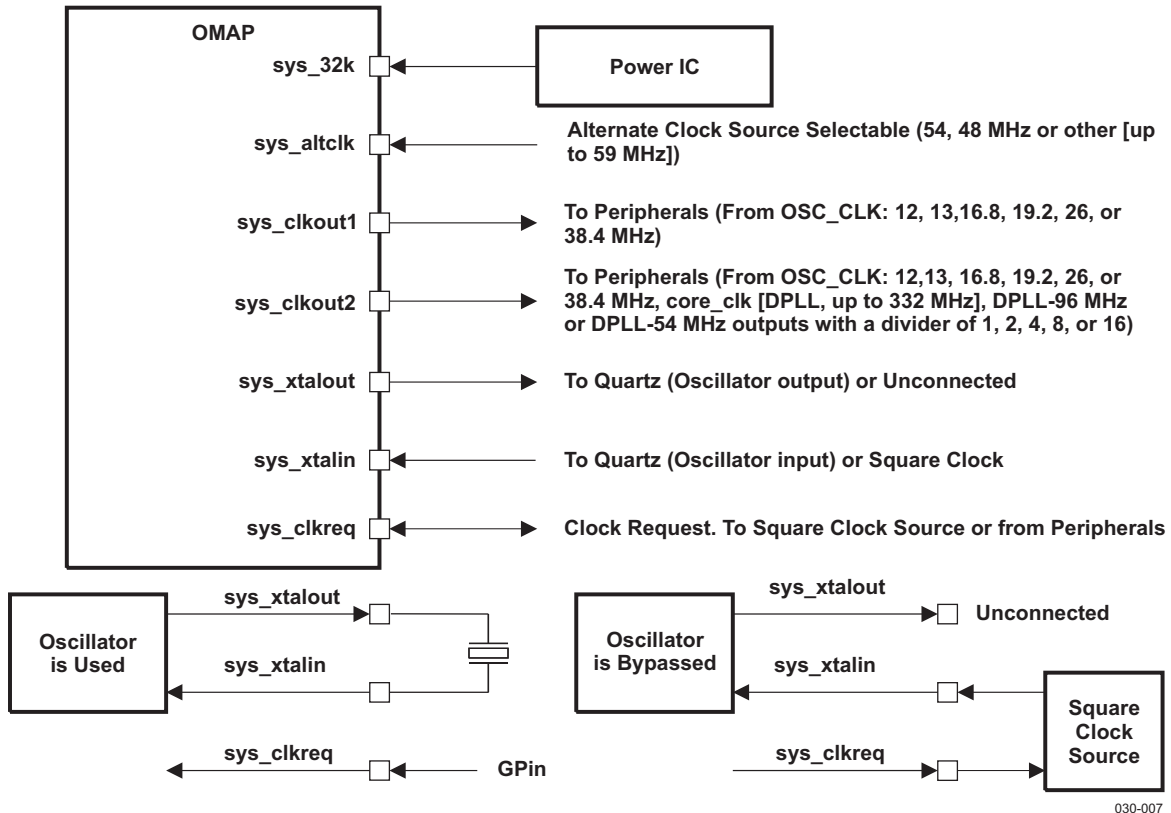

Figure 4-1. Clock Interface

The OMAP3530/25 device operation requires the following three input clocks:

- The 32-kHz frequency is used for low frequency operation. It supplies the wake-up domain for operation in lowest power mode (off mode). This clock is provided through the sys_32k pin.
- The system alternative clock can be used (through the sys_altclk pin) to provide alternative 48 or 54 MHz or other clock source (up to 59 MHz).
- The system clock input (12, 13, 16.8, 19.2, 26, or 38.4 MHz) is used to generate the main source clock of the OMAP3530/25 device. It supplies the DPLLs as well as several OMAP modules. The system clock input can be connected to either:
 - A crystal oscillator clock managed by sys_xtalin and sys_xtalout. In this case, the sys_clkreq is used as an input (GPIN).
 - A CMOS digital clock through the sys_xtalin pin. In this case, the sys_clkreq is used as an output to request the external system clock.

The OMAP3530/25 outputs externally two clocks:

- sys_clkout1 can output the oscillator clock (12, 13, 16.8, 19.2, 26, or 38.4 MHz) at any time. It can be controlled by software or externally using sys_clkreq control. When the device is in the off state, the sys_clkreq can be asserted to enable the oscillator and activate the sys_clkout1 without waking up the device. The off state polarity of sys_clkout1 is programmable.

- sys_clkout2 can output the oscillator clock (12, 13, 16.8, 19.2, 26, or 38.4 MHz), core_clk (core DPLL output), 96 MHz or 54 MHz. It can be divided by 2, 4, 8, or 16 and its off state polarity is programmable. This output is active only when the core power domain is active.

For more information on the OMAP3530/25 Applications Processor clocking structure, see the Power, Reset, and Clock management (PRCM) chapter of the *OMAP35x Applications Processor TRM* (literature number [SPRUFA5](#)).

4.1 Input Clock Specifications

The clock system accepts three input clock sources:

- 32-kHz digital CMOS clock
- Crystal oscillator clock or CMOS digital clock (12, 13, 16.8, 19.2, 26, or 38.4 MHz)
- Alternate clock (48 or 54 MHz, or other up to 59 MHz)

4.1.1 Clock Source Requirements

Table 4-1 illustrates the requirements to supply a clock to the OMAP3530/25 device.

Table 4-1. Clock Source Requirements

| PAD | CLOCK FREQUENCY | | STABILITY | DUTY CYCLE | JITTER | TRANSITION |
|-------------|-------------------------------------|---------|-----------|------------|--------|------------|
| sys_xtalout | 12, 13, 16.8, or 19.2 MHz | Crystal | ± 25 ppm | na | na | na |
| sys_xtalin | 12, 13, 16.8, 19.2, 26, or 38.4 MHz | Square | ± 50 ppm | 45% to 55% | < 1% | < 3.6 ns |
| sys_altclk | 48,54 or up to 59 MHz | | ± 50 ppm | 40% to 60% | < 1% | < 5 ns |

4.1.2 External Crystal Description

To supply a 12-, 13-, 16.8-, or 19.2-MHz clock to the OMAP3530/25, an external crystal can be connected to the sys_xtalin and sys_xtalout pins. Figure 4-2 describes the crystal implementation.

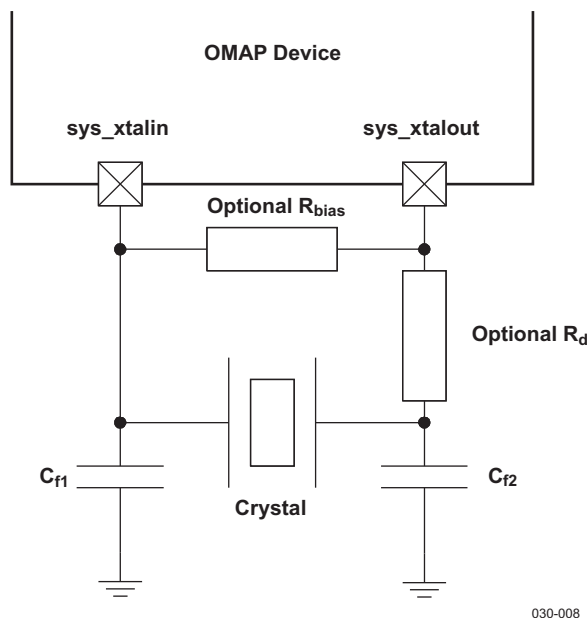

Figure 4-2. Crystal Implementation⁽¹⁾⁽²⁾⁽³⁾⁽⁴⁾

- (1) On the PCB, the oscillator components (crystal, foot capacitors, optional R_{bias} and R_d) must be located close to the package. All these components must be routed first with the lowest possible number of board vias.
- (2) An optional resistor R_d can be added in series with the crystal to debug or filter the harmonics; a footprint must be reserved on the PCB for use with 10-MHz crystals and feature low-drive levels.
- (3) A 120-k Ω internal bias resistor R_{bias} is used. The feedback resistor R_{bias} provides negative feedback to the oscillator to put it in the

linear operating region; thus oscillation begins when power is applied.

- (4) C_{f1} and C_{f2} represent the total capacitance of the PCB and components excluding the power IC and crystal. Their values in fact depend on the crystal datasheet. In the datasheet of the crystal, the frequency is specified at a specific load capacitor value which is the equivalent capacitor of the two capacitors C_{f1} and C_{f2} connected to sys_xtalin and sys_xtalout. The frequency of the oscillations depends on the value of the capacitors (10 pF corresponds to a load capacitor of 5 pF for the crystal).

The crystal must be in the fundamental mode of operation and parallel resonant. [Table 4-2](#) summarizes the required electrical constraints.

Table 4-2. Crystal Electrical Characteristics

| NAME | DESCRIPTION | MIN | TYP | MAX | UNIT |
|--------------|---|-----------------------|-----|-----|------------|
| f_p | Parallel resonance crystal frequency ⁽¹⁾ | 12, 13, 16.8, or 19.2 | | | MHz |
| C_L | Load capacitance for crystal parallel resonance | 5 | | 20 | pF |
| ESR12&13 | Crystal ESR (12 and 13 MHz) ⁽¹⁾ | | | 80 | Ω |
| ESR16.8&19.2 | Crystal ESR (16.8 and 19.2 MHz) ⁽¹⁾ | | | 50 | Ω |
| C_o | Crystal shunt capacitance | 1 | | 7 | pF |
| L_m | Crystal motional inductance for $f_p = 12$ MHz | | | 35 | mH |
| C_m | Crystal motional capacitance | 5 | | 100 | fF |
| DL | Crystal drive level | | | 0.5 | mW |
| R_{bias} | Internal bias resistor | 30 | 120 | 300 | k Ω |

- (1) Measured with the load capacitance specified by the crystal manufacturer. This load is defined by the foot capacitances tied in series. If $C_L = 20$ pF, then both foot capacitors will be $C_{f1} = C_{f2} = 40$ pF. Parasitic capacitance from package and board must also be taken in account.

$$ESR = R_m \left(1 + \frac{C_o}{C_L} \right)^2$$

When selecting a crystal, the system design must take into account the temperature and aging characteristics of a crystal versus the user environment and expected lifetime of the system. [Table 4-3](#) details the switching characteristics of the oscillator and the input requirements of the 12-, 13-, 16.8-, or 19.2-MHz input clock.

Table 4-3. Base Oscillator Switching Characteristics

| NAME | DESCRIPTION | MIN | TYP | MAX | UNIT |
|----------|---------------------------------|-----------------------|-----|-----|------|
| f_p | Oscillation frequency | 12, 13, 16.8, or 19.2 | | | MHz |
| t_{sX} | Start-up time ⁽¹⁾⁽²⁾ | 8 | | | ms |

- (1) Start-up time defined as time interval between oscillator control signal release and sys_xtalin amplitude at 50% of its final value (vdd and vdds supplies ramped and stable). The start-up time can be performed in function of the crystal characteristics. 8-ms minimum only when using the internal oscillator; it is programmable after reset for wake-up. At power-on reset, the time is adjustable using the pin itself. The reset must be released when the oscillator or clock source is stable. Before the processor boots up and the oscillator is set to bypass mode, there is a start-up time when the internal oscillator is in application mode and receives a square wave. The start-up time in this case is about 100 μ s.
- (2) For $f_p = 12$ or 13 MHz: $C_L = 13.5$ pF and $L_m = 35$ mH
For $f_p = 16.8$ or 19.2 MHz: $C_L = 9$ pF and $L_m = 15$ mH

4.1.3 Clock Squarer Input Description

A 1.8-V CMOS clock squarer is another source that can supply a 12-, 13-, 16.8-, 19.2-, 26-, or 38.4-MHz clock to the OMAP3530/25. An analog clock squarer function converts a low-amplitude sinusoidal clock into a low-jitter digital signal. It can be connected to input pin sys_xtalin (sys_xtalout unconnected). [Figure 4-3](#) illustrates the effective connections.

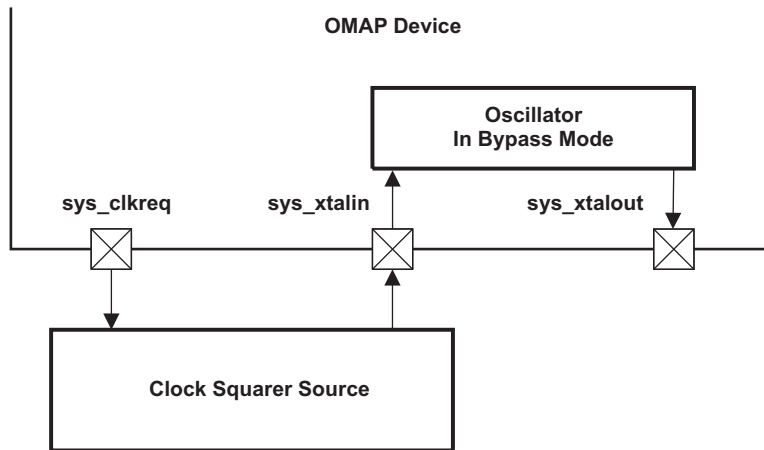

030-010

Figure 4-3. Clock Squarer Source Connection

To connect a digital clock source, the oscillator is configured in bypass mode⁽¹⁾. The sys_clkreq⁽²⁾ pin is an OMAP3530/25 output which can be used to switch the clock source on or off.

1. Pin sys_xtalout is not used in this mode. It must be left unconnected.
2. Once the system is powered up, the clock squarer source or crystal oscillator source can be applied; however, this affects the performance. The input source must be configured after power up to attain the desired system requirements.

Table 4-4 summarizes the electrical constraints required by the clock squarer used in the fundamental mode of operation.

Note: There is an internal pulldown resistor of 5k Ω (max.) on sys_xtalin when the oscillator is disabled.

Table 4-4. Base Oscillator Electrical Characteristics (in Bypass Mode)

| NAME | DESCRIPTION | MIN | TYP | MAX | UNIT |
|------------------|--|---------------------------------|-----|-----|-------------------|
| f | Frequency ⁽¹⁾ | 12, 13, 16.8, 19.2, 26, or 38.4 | | | MHz |
| t _{sX} | Start-up time | | | | ⁽²⁾ ms |
| I _{DDQ} | Current consumption on VDD5 when sys_xtalin = 0 and in power-down mode | | | 1 | μA |

- (1) Measured with the load capacitance specified by the manufacturer. Parasitic capacitance from package and board must also be taken in account.
- (2) Before the processor boots up and the oscillator is set to bypass mode, there is a start-up time when the internal oscillator is in application mode and receives a square wave. The start-up time in this case is about 100 μs.

Table 4-5 details the input requirements of the 12-, 13-, 16.8-, 19.2-, 26-, or 38.4-MHz input clock.

Table 4-5. 12-, 13-, 16.8-, 19.2-, 26-, or 38.4-MHz Input Clock Squarer Timing Requirements

| NAME | DESCRIPTION | | MIN | TYP | MAX | UNIT |
|------|----------------------------|---|---------------------------------|-----|-------------------------------|------|
| OCS0 | 1 / t _{c(xtalin)} | Frequency, sys_xtalin | 12, 13, 16.8, 19.2, 26, or 38.4 | | | MHz |
| OCS1 | t _{w(xtalin)} | Pulse duration, sys_xtalin low or high | 0.45 * t _{c(xtalin)} | | 0.55 * t _{c(xtalin)} | ns |
| OCS2 | t _{J(xtalin)} | Peak-to-peak jitter ⁽¹⁾ , sys_xtalin | -1% | | 1% | |
| OCS3 | t _{R(xtalin)} | Rise time, sys_xtalin | | | 3.6 | ns |
| OCS4 | t _{F(xtalin)} | Fall time, sys_xtalin | | | 3.6 | ns |
| OCS5 | t _{J(xtalin)} | Frequency stability, sys_xtalin | | | ±25 | ppm |

- (1) Peak-to-peak jitter is defined as the difference between the maximum and the minimum output periods on a statistical population of 300 period samples. The sinusoidal noise is added on top of the vdds supply voltage.

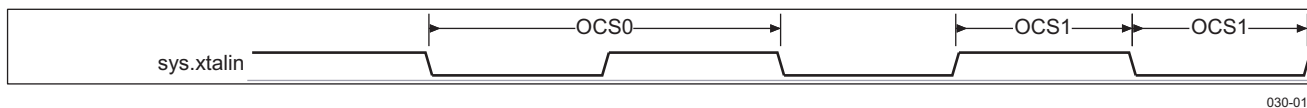

030-011

Figure 4-4. Crystal Oscillator in Bypass Mode

4.1.4 External 32-kHz CMOS Input Clock

A 32.768-kHz clock signal (often abbreviated to 32-kHz) can be supplied by an external 1.8-V CMOS signal on pin sys_32k.

Table 4-6 summarizes the electrical constraints imposed to the clock source.

Table 4-6. 32-kHz Input Clock Source Electrical Characteristics

| NAME | DESCRIPTION | MIN | TYP | MAX | UNIT |
|----------------|-------------------|--------|------|-----------------|------|
| f | Frequency | 32.768 | | | kHz |
| C _I | Input capacitance | | 0.44 | | pF |
| R _I | Input resistance | 0.25 | | 10 ⁶ | GΩ |

Table 4-7 details the input requirements of the 32-kHz input clock.

Table 4-7. 32-kHz Input Clock Source Timing Requirements⁽¹⁾

| NAME | DESCRIPTION | | MIN | TYP | MAX | UNIT |
|------|-------------------------|------------------------------|-----|--------|------|------|
| CK0 | 1 / t _{c(32k)} | Frequency, sys_32k | | 32.768 | | kHz |
| CK3 | t _{R(32k)} | Rise time, sys_32k | | | 20 | ns |
| CK4 | t _{F(32k)} | Fall time, sys_32k | | | 20 | ns |
| CK5 | t _{J(32k)} | Frequency stability, sys_32k | | | ±200 | ppm |

(1) See Table 3-4, Electrical Characteristics, Standard LVC MOS IOs part for sys_32k V_{IH}/V_{IL} parameters.

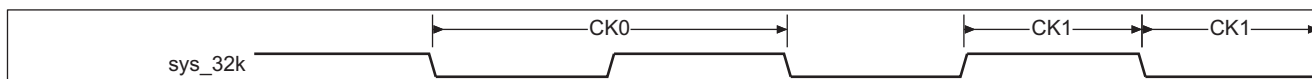

030-012

Figure 4-5. 32-kHz CMOS Clock

4.1.5 External sys_altclk CMOS Input Clock

A 48-, 54-, or up to 59- MHz clock signal can be supplied by an external 1.8-V CMOS signal on pin sys_altclk.

Table 4-8 summarizes the electrical constraints imposed by the clock source.

Table 4-8. 48-, 54-, or up to 59- MHz Input Clock Source Electrical Characteristics

| NAME | DESCRIPTION | MIN | TYP | MAX | UNIT |
|----------------|-----------------------|----------------------------|------|-----------------|------|
| f | Frequency, sys_altclk | 48-, 54-, or up to 59- MHz | | | MHz |
| C _I | Input capacitance | | 0.74 | | pF |
| R _I | Input resistance | 0.25 | | 10 ⁶ | GΩ |

Table 4-9 details the input requirements of the input clock.

Table 4-9. 48- or 54-MHz Input Clock Source Timing Requirements⁽¹⁾⁽²⁾

| NAME | DESCRIPTION | MIN | TYP | MAX | UNIT |
|------|---|----------------------------|-----|------------------------|------|
| ALT0 | $1 / t_{c(altclk)}$ Frequency, sys_altclk | 48-, 54-, or up to 59- MHz | | | MHz |
| ALT1 | $t_{w(altclk)}$ Pulse duration, sys_altclk low or high | $0.40 * t_{c(altclk)}$ | | $0.60 * t_{c(altclk)}$ | ns |
| ALT2 | $t_{j(altclk)}$ Peak-to-peak jitter ⁽¹⁾ , sys_altclk | -1% | | 1% | |
| ALT3 | $t_{R(altclk)}$ Rise time, sys_altclk | | | 10 | ns |
| ALT4 | $t_{F(altclk)}$ Fall time, sys_altclk | | | 10 | ns |
| ALT5 | $t_{J(altclk)}$ Frequency stability, sys_altclk | | | ± 50 | ppm |

- (1) Peak-to-peak jitter is defined as the difference between the maximum and the minimum output periods on a statistical population of 300 period samples. The sinusoidal noise is added on top of the vdds supply voltage.
- (2) See [Table 3-4, Electrical Characteristics](#), for sys_altclk V_{IH}/V_{IL} parameters.

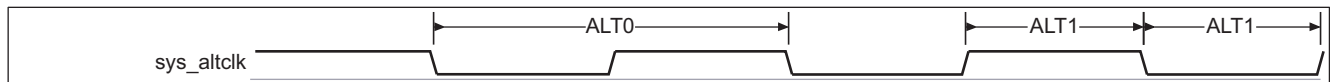

030-013

Figure 4-6. Alternate CMOS Clock

4.2 Output Clock Specifications

Two output clocks (pin sys_clkout1 and pin sys_clkout2) are available:

- sys_clkout1 can output the oscillator clock (12, 13, 16.8, 19.2, 26, or 38.4 MHz) at any time. It can be controlled by software or externally using sys_clkreq control. When the device is in the off state, the sys_clkreq can be asserted to enable the oscillator and activate the sys_clkout1 without waking up the device. The off state polarity of sys_clkout1 is programmable.
- sys_clkout2 can output sys_clk (12, 13, 16.8, 19.2, 26, or 38.4 MHz), CORE_CLK (core DPLL output, 332 MHz maximum), APPL-96 MHz, or APPL-54 MHz. It can be divided by 2, 4, 8, or 16 and its off state polarity is programmable. This output is active only when the core domain is active.

Table 4-10 summarizes the sys_clkout1 output clock electrical characteristics.

Table 4-10. sys_clkout1 Output Clock Electrical Characteristics

| NAME | DESCRIPTION | MIN | TYP | MAX | UNIT |
|----------------|---------------------------------|---------------------------------|-----|-----|------|
| f | Frequency | 12, 13, 16.8, 19.2, 26, or 38.4 | | | MHz |
| C _I | Load capacitance ⁽¹⁾ | f(max) = 38.4 MHz | 37 | | pF |
| | | f(max) = 26 MHz | 50 | | |

(1) The load capacitance is adapted to a frequency.

Table 4-11 details the sys_clkout1 output clock timing characteristics.

Table 4-11. sys_clkout1 Output Clock Switching Characteristics

| NAME | DESCRIPTION | MIN | TYP | MAX | UNIT |
|------|-------------------------|-----------------------------------|-----|-----------------------------------|------|
| f | 1 / CO0 | 12, 13, 16.8, 19.2, 26, or 38.4 | | | MHz |
| CO1 | t _{w(CLKOUT1)} | 0.40 * t _{c(CLKOUT1)} | | 0.60 * t _{c(CLKOUT1)} | ns |
| CO2 | t _{R(CLKOUT1)} | | | 5.5 | ns |
| CO3 | t _{F(CLKOUT1)} | | | 5.5 | ns |

(1) With a load capacitance of 50 pF.

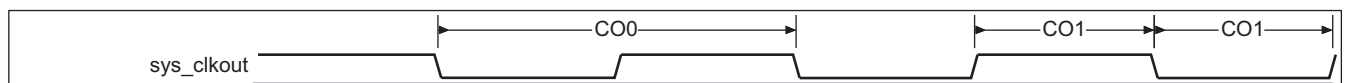

030-014

Figure 4-7. sys_clkout1 System Output Clock

Table 4-12 summarizes the sys_clkout2 output clock electrical characteristics.

Table 4-12. sys_clkout2 Output Clock Electrical Characteristics

| NAME | DESCRIPTION | MIN | TYP | MAX | UNIT |
|----------------|---------------------------------|------------------|-----|-----|------|
| f | Frequency, sys_clkout2 | | | 322 | MHz |
| C _L | Load capacitance ⁽¹⁾ | f(max) = 166 MHz | 2 | 8 | 12 |

(1) The load capacitance is adapted to a frequency.

Table 4-13 details the sys_clkout2 output clock timing characteristics.

Table 4-13. sys_clkout2 Output Clock Switching Characteristics

| NAME | DESCRIPTION | | MIN | TYP | MAX | UNIT |
|------|-------------------------|---|--------------------------------|-----|--------------------------------|------|
| f | 1 / CO0 | Frequency | | | 322 | MHz |
| CO1 | $t_{w(\text{CLKOUT2})}$ | Pulse duration, sys_clkout2 low or high | $0.40 * t_{c(\text{CLKOUT2})}$ | | $0.60 * t_{c(\text{CLKOUT2})}$ | ns |
| CO2 | $t_{R(\text{CLKOUT2})}$ | Rise time, sys_clkout2 ⁽¹⁾ | | | 3.7 | ns |
| CO3 | $t_{F(\text{CLKOUT2})}$ | Fall time, sys_clkout2 ⁽¹⁾ | | | 4.3 | ns |

(1) With a load capacitance of 12 pF.

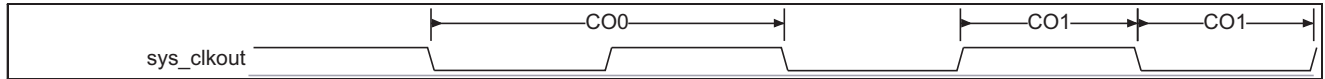

030-015

Figure 4-8. sys_clkout2 System Output Clock

4.3 DPLL and DLL Specifications

The OMAP3530/25 integrates seven DPLLs and a DLL. The PRM and CM drive five of them, while the sixth (not supported) and the seventh (not supported) are controlled by the display subsystem.

The five main DPLLs are:

- DPLL1 (MPU)
- DPLL2 (IVA2)
- DPLL3 (Core)
- DPLL4 (Peripherals)
- DPLL5 (Second Peripherals DPLL)

Figure 4-9 illustrates the DLL and DPLL implementation.

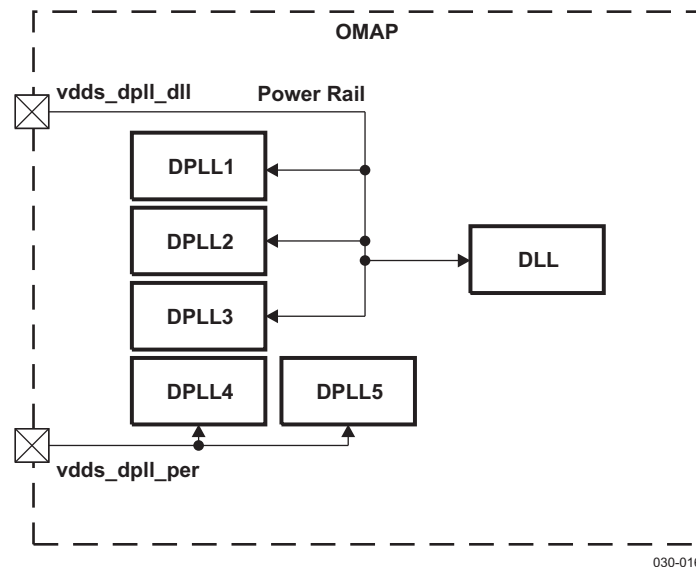

(1) **Figure 4-9. DPLL and DLL Implementation**

For more information on the OMAP3530/25 Applications Processor DPLLs and clocking structure, see the Power, Reset, and Clock management (PRCM) chapter of the *OMAP35x Applications Processor TRM* (literature number [SPRUFA5](#)).

4.3.1 Digital Phase-Locked Loop (DPLL)

The DPLL provides all interface clocks and some functional clocks (such as the processor clocks) of the OMAP3530/25 device.

DPLL1 and DPLL2 get an always-on clock used to produce the synthesized clock. They get a high-speed bypass clock used to switch the DPLL output clock on this high-speed clock during bypass mode.

The high-speed bypass clock is an L3 divided clock (programmable by 1 or 2) that saves DPLL processor power consumption when the processor does not need to run faster than the L3 clock speed, or optimizes performance during frequency scaling.

Each DPLL synthesized frequency is set by programming M (multiplier) and N (divider) factors. In addition, all DPLL outputs can be controlled by an independent divider (M2 to M6).

The clock generating DPLLs of the OMAP3530/25 device have following features:

- Independent power domain per DPLL
- Controlled by clock-manager (CM)
- Fed with always-on system clock with independent gating control per DPLL

- Analog part supplied through dedicated power supply (1.8 V) and an embedded LDO to get rid of 1-MHz noise
- Up to five independent output dividers for simultaneous generation of multiple clock frequencies

4.3.1.1 DPLL1 (MPU)

DPLL1 is located in the MPU subsystem and supplies all clocks of the subsystem. All MPU subsystem clocks are internally generated in the subsystem. When the core domain is on, it can use the DPLL3 (CORE DPLL) output as a high-frequency bypass input clock.

4.3.1.2 DPLL2 (IVA2)

DPLL2 is located in the IVA subsystem and supplies all clocks of the subsystem. All IVA subsystem clocks are internally generated in the subsystem. When the core domain is on, it can use the DPLL3 (CORE DPLL) output as a high-frequency bypass input clock.

4.3.1.3 DPLL3 (CORE)

DPLL3 supplies all interface clocks and also a few module functional clocks. It can be also source of the emulation trace clock. It is located in the core domain area. All interface clocks and a few module functional clocks are generated in the CM. When the core domain is on, it can be used as a bypass input to DPLL1 and DPLL2.

4.3.1.4 DPLL4 (Peripherals)

DPLL4 generates clocks for the peripherals. It supplies five clock sources: 96-MHz functional clocks to subsystems and peripherals, 54 MHz to TV DAC, display functional clock, camera sensor clock, and emulation trace clock. It is located in the core domain area. All interface clocks and few module functional clocks are generated in the CM. Its outputs to the DSS, PER, and EMU domains are propagated with always-on clock trees.

4.3.1.5 DPLL5 (Second peripherals DPLL)

DPLL5 supplies the 120-MHz functional clock to the CM.

4.3.2 Delay-Locked Loops (DLL)

The SDRC includes analog-controlled delay technology for interfacing high-speed mobile DDR memory components. For more information, see the SDRC-GPMC chapter of the *OMAP35x Technical Reference Manual (TRM)* [literature number [SPRUF98](#)]. A DLL is a calibration module used on dynamic track of voltage and temperature variations, as well as to compensate the silicon process dispersion.

The SDRC DLL has four modes of operation:

1. APPLICATION MODE 0: used to generate 72° delay
2. APPLICATION MODE 1: used to generate 90° delay
3. MODEMAXDELAY: used for low frequency operation where we do not have the requirement of accurate 72° or 90° phase shift
4. IDLE MODE: a low-power state that allows the DLL to gain lock quickly on exit from this mode

4.3.3 DPLLs and DLL Characteristics

Several specifications characterize the seven DPLLs.

Table 4-14 summarizes the DPLL characteristics and assumes testing over recommended operating conditions.

Table 4-14. DPLL Characteristics

| NAME | PARAMETER | MIN | TYP | MAX | UNIT | COMMENTS ⁽¹⁾ |
|-----------------------|---|-------|-----|-------|------|--|
| vdds_dp1l_per | | 1.71 | 1.8 | 1.89 | V | At ball level (+5%, +10%) |
| vdds_dp1l_dll | | 1.71 | 1.8 | 1.89 | V | |
| T _J | Junction temperature | –40 | 25 | 105 | °C | Will not unlock after lock over this range for slow temperature drifts |
| f _{input} | Input reference frequency ⁽²⁾ | 0.75 | | 65 | MHz | FINP |
| f _{internal} | Internal reference frequency | 0.75 | | 2.1 | MHz | FREQSEL3 = 0; FINT = FINP/(N+1) |
| | | 7.5 | | 21 | MHz | FREQSEL3 = 1; FINT = FINP/(N+1) |
| f _{output} | CLKOUT output frequency | 25 | | 900 | MHz | |
| f _{output*2} | CLKOUTx2 output frequency | 50 | | 1800 | MHz | |
| t _{lock} | Frequency lock time ⁽³⁾ | 71.4 | | 200 | μs | 150 FINT cycles; FREQSEL3 = 0 |
| | | 37.1 | | 104 | μs | 780 FINT cycles; FREQSEL3 = 1 |
| p _{lock} | Phase lock time | 166.7 | | 466.7 | μs | 350 FINT cycles; FREQSEL3 = 0 |
| | | 46.7 | | 130.7 | μs | 980 FINT cycles; FREQSEL3 = 1 |
| t _{relock} | Relock time – frequency lock ⁽⁴⁾ | 4.8 | | 13.3 | μs | 10 FINT cycles Lowcurrstby = 0; FREQSEL3 = 0 |
| | | 4.8 | | 13.3 | μs | 100 FINT cycles Lowcurrstby = 0; FREQSEL3 = 1 |
| | | 19 | | 53.3 | μs | 40 FINT cycles Lowcurrstby = 1; FREQSEL3 = 0 |
| | | 19 | | 53.3 | μs | 400 FINT cycles Lowcurrstby = 1; FREQSEL3 = 1 |
| | | 71.4 | | 200 | μs | 150 FINT cycles Lowcurrstby = 0; FREQSEL3 = 0 |
| | | 11.9 | | 33.3 | μs | 250 FINT cycles Lowcurrstby = 0; FREQSEL3 = 1 |
| p _{relock} | Relock time – Phase lock ⁽⁴⁾ | 95.2 | | 266.7 | μs | 200 FINT cycles Lowcurrstby = 1; FREQSEL3 = 0 |
| | | 26.7 | | 74.7 | μs | 560 FINT cycles Lowcurrstby = 1; FREQSEL3 = 1 |

and Table 4-16 show the DPLL1 and DPLL2 clock frequency ranges.

Note: The DPLL1 and DPLL2 clock frequency ranges depend on the V_{DD1} (vdd_mpu_iva) operating point.

- (1) f_{reqsel} needs to be programmed accordingly to reference clock and DPLL divider (register setting), Lowcurrstby depends on the targeted DPLL power state (dynamic).
Lowcurrstby = 0 then DPLL is in normal mode
Lowcurrstby = 1 then DPLL is in low-power mode
- (2) Input frequencies below 0.75 MHz are possible with performance penalty.
- (3) Maximum frequency for nominal conditions. Speed binning possible above f_{max}.
- (4) Relock time assumes typical operating conditions, 4°C maximum temperature drift (see the Functional Specification for more detailed information).

Table 4-15. DPLL1 Clock Frequency Ranges

| Clock Signal | Description | | Max | Unit |
|--------------|---------------------|---------------------|-----|------|
| ARM_CLK | DPLL1 output clock. | OPP6 ⁽¹⁾ | 720 | MHz |
| | | OPP5 | 600 | MHz |
| | | OPP4 | 550 | MHz |
| | | OPP3 | 500 | MHz |
| | | OPP2 | 250 | MHz |
| | | OPP1 ⁽²⁾ | 125 | MHz |

- (1) OPP6 frequency range is only supported on high-speed grade OMAP3530/25 devices.
- (2) Cannot boot in OPP1. If OPP1 is desired, boot in higher OPP then switch to OPP1.

Table 4-16. DPLL2 Clock Frequency Ranges

| Clock Signal | Description | | Max | Unit |
|--------------|------------------------------------|---------------------|-----|------|
| IVA2_CLK | Generated from DPLL2 output clock. | OPP6 ⁽¹⁾ | 520 | MHz |
| | | OPP5 | 430 | MHz |
| | | OPP4 | 400 | MHz |
| | | OPP3 | 360 | MHz |
| | | OPP2 | 180 | MHz |
| | | OPP1 ⁽²⁾ | 90 | MHz |

- (1) OPP6 frequency range is only supported on high-speed grade OMAP3530/25 devices.
- (2) Cannot boot in OPP1. If OPP1 is desired, boot in higher OPP then switch to OPP1.

Table 4-17 through Table 4-19 show the DPLL3 clock frequency ranges.

Note: The DPLL3 clock frequency ranges depend on the VDD2 (vdd_core) operating point and the L3 clock speed configuration.

Table 4-17. DPLL3 Clock Frequency Ranges, VDD2 OPP3

| Clock Signal | Description | Config 1 (166 MHz) | | Config 2 (133 MHz) | | Config 3 (100 MHz) | | Unit |
|--------------|---|--------------------|--------|--------------------|-------|--------------------|-------|------|
| | | Min | Max | Min | Max | Min | Max | |
| CM: CORE_CLK | Output of clock manager (CM), generated directly from DPLL3. | - | 332 | - | 266 | - | 200 | MHz |
| CM: L3_ICLK | Output of clock manager (CM), generated using DPLL3. | - | 166 | - | 133 | - | 100 | MHz |
| CM: L4_ICLK | Output of clock manager (CM), generated using CM L3_ICLK and divider. | - | 83 | - | 66.5 | - | 50 | MHz |
| SGX | SGX input clock, taken from CM CORE_CLK. | - | 110.67 | - | 88.67 | - | 66.67 | MHz |
| SDRC | SDRC input clock, taken from CM L3_ICLK. | - | 166 | - | 133 | - | 100 | MHz |
| GPMC | GPMC input clock, taken from CM L3_ICLK. | - | 83 | - | 66.5 | - | 100 | MHz |

Table 4-18. DPLL3 Clock Frequency Ranges, VDD2 OPP2

| Clock Signal | Description | Config 1 (83 MHz) | | Config 2 (100 MHz) | | Unit |
|--------------|--|-------------------|-----|--------------------|-----|------|
| | | Min | Max | Min | Max | |
| CM: CORE_CLK | Output of clock manager (CM), generated directly from DPLL3. | - | 166 | - | 200 | MHz |
| CM: L3_ICLK | Output of clock manager (CM), generated using DPLL3. | - | 83 | - | 100 | MHz |

Table 4-18. DPLL3 Clock Frequency Ranges, VDD2 OPP2 (continued)

| Clock Signal | Description | Config 1 (83 MHz) | | Config 2 (100 MHz) | | Unit |
|--------------|---|----------------------|-------|-----------------------|-------|------|
| | | Min | Max | Min | Max | |
| CM: L4_ICLK | Output of clock manager (CM), generated using CM L3_ICLK and divider. | - | 41.5 | - | 50 | MHz |
| SGX | SGX input clock, taken from CM CORE_CLK. | - | 55.53 | - | 66.67 | MHz |
| SDRC | SDRC input clock, taken from CM L3_ICLK. | - | 83 | - | 100 | MHz |
| GPMP | GPMP input clock, taken from CM L3_ICLK. | - | 83 | - | 50 | MHz |

Table 4-19. DPLL3 Clock Frequency Ranges, VDD2 OPP1⁽¹⁾

| Clock Signal | Description | Config 1 (40 MHz) | | Unit |
|--------------|---|----------------------|-------|------|
| | | Min | Max | |
| CM: CORE_CLK | Output of clock manager (CM), generated directly from DPLL3. | - | 83 | MHz |
| CM: L3_ICLK | Output of clock manager (CM), generated using DPLL3. | - | 41.5 | MHz |
| CM: L4_ICLK | Output of clock manager (CM), generated using CM L3_ICLK and divider. | - | 20.75 | MHz |
| SGX | SGX input clock, taken from CM CORE_CLK. | - | N/A | MHz |
| SDRC | SDRC input clock, taken from CM L3_ICLK. | - | 41.5 | MHz |
| GPMP | GPMP input clock, taken from CM L3_ICLK. | - | 41.5 | MHz |

(1) Cannot boot in OPP1. If OPP1 is desired, boot in higher OPP then switch to OPP1.

Table 4-20 summarizes the DLL characteristics.

Table 4-20. DLL Characteristics

| PARAMETER | MIN | NOM | MAX | UNIT | COMMENTS |
|---|------|-----|------|--------|-----------------------------------|
| Supply voltage vdds_dp11_dll | 1.71 | 1.8 | 1.89 | V | |
| Junction operating temperature | -40 | 25 | 105 | °C | |
| Input clock frequency | 66 | 120 | 133 | MHz | APPLICATION MODE 0 |
| | 83 | 120 | 166 | | APPLICATION MODE 1 |
| Input load ⁽¹⁾ | | | 15 | fF | |
| Lock time ⁽²⁾ | | | 500 | Clocks | |
| Relock time (Mode transitions through idle mode) | | | 500 | ns | IDLE to MODEMAXDELAY |
| | | 150 | 372 | Clocks | IDLE to APPLICATION MODE 1 or 0 |
| | | 1 | 2 | µs | IDLE to APPLICATION MODE @133 MHz |
| | | 1 | 1.5 | µs | IDLE to APPLICATION MODE @166 MHz |

(1) This parameter is design goal and is not tested on silicon.

(2) Lock signal would go high from power down within 500 clocks. Lock signal switches to low state when the input clock is switched off after 3 µs.

4.3.4 DPLL and DLL Noise Isolation

The DPLL and DLL require dedicated power supply pins to isolate the core analog circuit from the switching noise generated by the core logic that can cause jitter on the clock output signal. Guard rings are added to the cell to isolate it from substrate noise injection.

The vdd supplies are the most sensitive to noise; decoupling capacitance is recommended below the supply rails. The maximum input noise level allowed is 30 mV_{PP} for frequencies below 1 MHz.

Figure 4-10 illustrates an example of a noise filter.

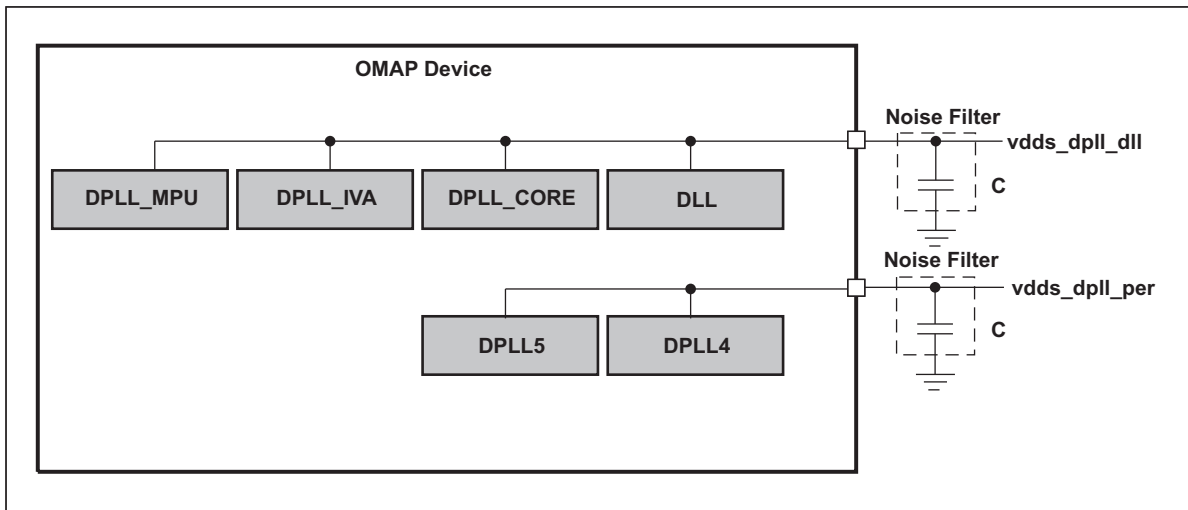

030-017

Figure 4-10. DPLL and DLL Noise Filter

Table 4-21 specifies the noise filter requirements.

Table 4-21. DPLL and DLL Noise Filter Requirements

| NAME | MIN | TYP | MAX | UNIT |
|---------------------|-----|-----|-----|------|
| Filtering capacitor | | 100 | | nF |

- (1) The capacitors must be inserted between power and ground as close as possible.
- (2) This circuit is provided only as an example.
- (3) The filter must be located as close as possible to the device.
- (4) No filtering required if noise is below 10 mV_{PP}.

5 VIDEO DAC SPECIFICATIONS

A dual-display interface equips the OMAP3530/25 processor. This display subsystem provides the necessary control signals to interface the memory frame buffer directly to the external displays (TV-set). Two (one per channel) 10-bit current steering DACs are inserted between the DSS and the TV set to generate the video analog signal. One of the video DACs also includes TV detection and power-down mode. Figure 5-1 illustrates the OMAP3530/25 DAC architecture. For more information, see the DSS chapter of the *OMAP35x Technical Reference Manual (TRM)* [literature number [SPRUF98](#)].

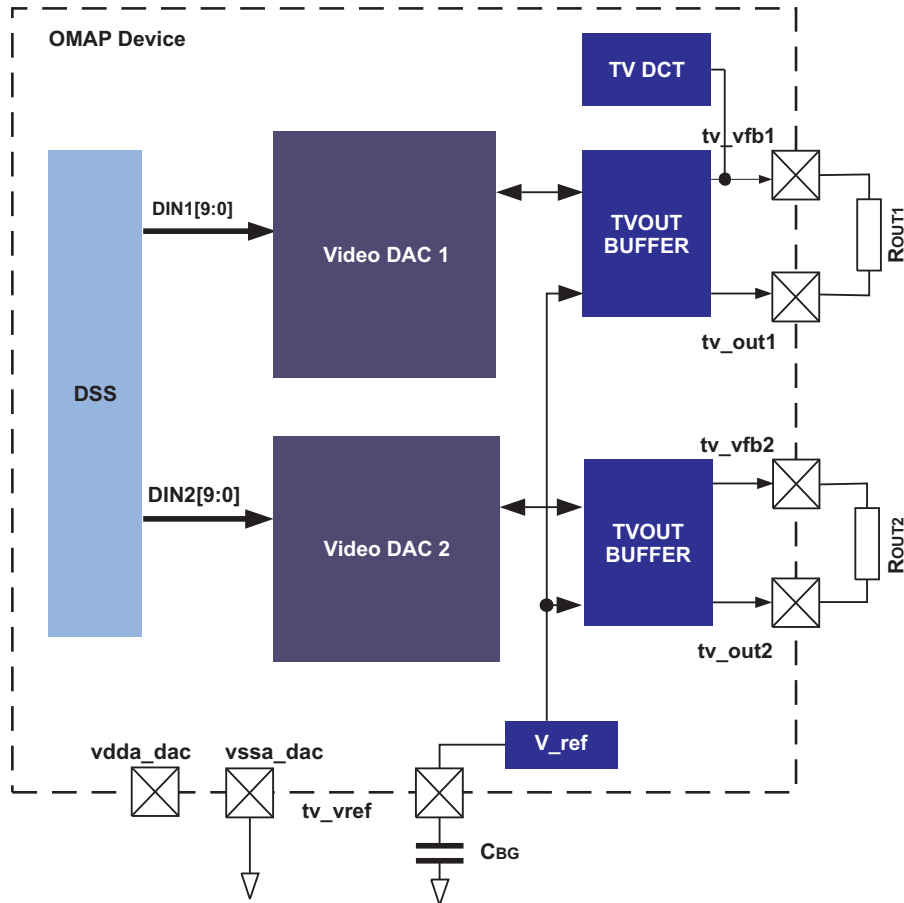

030-018

Figure 5-1. Video DAC Architecture

The following paragraphs detail the 10-bit DAC interface pinout, static and dynamic specifications, and noise requirements. The operating conditions and absolute maximum ratings are detailed in [Table 5-2](#) and [Table 5-4](#).

5.1 Interface Description

[Table 5-1](#) summarizes the external pins of the video DAC.

Table 5-1. External Pins of 10-bit Video DAC

| PIN NAME | I/O | DESCRIPTION | |
|----------|-----|----------------------------|---|
| tv_out1 | O | TV analog output composite | DAC1 video output. An external resistor is connected between this node and tv_vfb1. The nominal value of ROUT1 is 1650 Ω. Finally, note that this is the output node that drives the load (75 Ω). |

Table 5-1. External Pins of 10-bit Video DAC (continued)

| PIN NAME | I/O | DESCRIPTION | |
|----------|-----|--|---|
| tv_out2 | O | TV analog output S-VIDEO | DAC2 video output. An external resistor is connected between this node and tv_vfb2. The nominal value of ROUT2 is 1650 Ω . Finally, note that this is the output node that drives the load (75 Ω). |
| tv_vref | I | Reference output voltage from internal bandgap | A decoupling capacitor (CBG) needs to be connected for optimum performance. |
| tv_vfb1 | O | Amplifier feedback node | Amplifier feedback node. An external resistor is connected between this node and tv_out1. The nominal value of ROUT1 is 1650 Ω (1%). |
| tv_vfb2 | O | Amplifier feedback node | Amplifier feedback node. An external resistor is connected between this node and tv_out2. The nominal value of ROUT2 is 1650 Ω (1%). |

5.2 Electrical Specifications Over Recommended Operating Conditions

(T_{MIN} to T_{MAX} , $v_{dda_dac} = 1.8\text{ V}$, $R_{OUT1/2} = 1650\ \Omega$, $R_{LOAD} = 75\ \Omega$, unless otherwise noted)

Table 5-2. DAC – Static Electrical Specification

| PARAMETER | | CONDITIONS/ASSUMPTIONS | MIN | TYP | MAX | UNIT |
|--------------------------|---|---|-------|------|-------|----------|
| R | Resolution | | | 10 | | Bits |
| DC ACCURACY | | | | | | |
| INL ⁽¹⁾ | Integral nonlinearity | | –1 | | 1 | LSB |
| DNL ⁽²⁾ | Differential nonlinearity | | –1 | | 1 | LSB |
| ANALOG OUTPUT | | | | | | |
| - | Full-scale output voltage | $R_{LOAD} = 75\ \Omega$ | 0,7 | 0.88 | 1 | V |
| - | Output offset voltage | | | 50 | | mV |
| - | Output offset voltage drift | | | 20 | | mV/°C |
| - | Gain error | | –17 | | 19 | % FS |
| R_{VOUT} | Output impedance | | 67.5 | 75 | 82.5 | Ω |
| REFERENCE | | | | | | |
| V_{REF} | Reference voltage range | | 0.525 | 0.55 | 0.575 | V |
| - | Reference noise density | 100-kHz reference noise bandwidth | | 129 | | |
| R_{SET} | Full-scale current adjust resistor | | 3700 | 4000 | 4200 | Ω |
| P_{SRR} | Reference PSRR ⁽³⁾ (Up to 6 MHz) | | | 40 | | dB |
| POWER CONSUMPTION | | | | | | |
| $I_{vdda-up}$ | Analog Supply Current ⁽⁴⁾ | 2 channels, no load | | 8 | | mA |
| - | Analog supply driving a 75- Ω load (RMS) | 2 channels | | 50 | | mA |
| $I_{vdda-up}$ (peak) | Peak analog supply current: | Lasts less than 1 ns | | 60 | | mA |
| I_{vdd-up} | Digital supply current ⁽⁵⁾ | Measured at $f_{CLK} = 54\text{ MHz}$, $f_{OUT} = 2\text{ MHz}$ sine wave, $v_{dd} = 1.3\text{ V}$ | | 2 | | mA |
| I_{vdd-up} (peak) | Peak digital supply current ⁽⁶⁾ | Lasts less than 1 ns | | 2.5 | | mA |
| $I_{vdda-down}$ | Analog power at power-down | $T = 30^\circ\text{C}$, $v_{dda} = 1.8\text{ V}$ | | 1.5 | | mA |
| $I_{vdd-down}$ | Digital power at power-down | $T = 30^\circ\text{C}$, $v_{dd} = 1.3\text{ V}$ | | 1 | | mA |

(1) The INL is measured at the output of the DAC (accessible at an external pin during bypass mode).

(2) The DNL is measured at the output of the DAC (accessible at an external pin during bypass mode).

(3) Assuming a capacitor of 0.1 μF at the tv_ref node.

(4) The analog supply current I_{vdda} is directly proportional to the full-scale output current IFS and is insensitive to f_{CLK} .

(5) The digital supply current I_{VDD} is dependent on the digital input waveform, the DAC update rate f_{CLK} , and the digital supply VDD.

(6) The peak digital supply current occurs at full-scale transition for duration less than 1 ns.

(T_{MIN} to T_{MAX} , $v_{dda_dac} = 1.8\text{ V}$, $R_{OUT1/2} = 1650\ \Omega$, $R_{LOAD} = 75\ \Omega$, unless otherwise noted)

Table 5-3. Video DAC – Dynamic Electrical Specification

| | PARAMETER | CONDITIONS/ASSUMPTIONS | MIN | TYP | MAX | UNIT |
|-----------------|---|---|-----|-------------------|-----|------|
| $f_{CLK}^{(1)}$ | Output update rate | Equal to input clock frequency | | 54 | | MHz |
| | Clock jitter | rms clock jitter required in order to assure 10-bit accuracy | | | 40 | ps |
| | Attenuation at 5.1 MHz | Corner frequency for signal | 0.1 | 0.5 | 1.5 | dB |
| | Attenuation at 54 MHz ⁽¹⁾ | Image frequency | 25 | 30 | 33 | dB |
| t_{ST} | Output settling time | Time from the start of the output transition to output within ± 1 LSB of final value. | | 85 | | ns |
| t_{Rout} | Output rise time | Measured from 10% to 90% of full-scale transition | | 25 | | ns |
| t_{Fout} | Output fall time | Measured from 10% to 90% of full-scale transition | | 25 | | ns |
| BW | Signal bandwidth | | | 6 | | MHz |
| | Differential gain ⁽²⁾ | | | 1.5% | | |
| | Differential phase ⁽²⁾ | | | 1 | | deg. |
| SFDR | Within bandwidth | $f_{CLK} = 54\text{ MHz}$, $f_{OUT} = 1\text{ MHz}$ | | 45 | | dB |
| SNR | Signal-to-noise ratio 1 kHz to 6 MHz bandwidth | $f_{CLK} = 54\text{ MHz}$, $f_{OUT} = 1\text{ MHz}$ | | 55 ⁽³⁾ | | dB |
| PSRR | Power supply rejection ratio | Up to 6 MHz | | 20 ⁽⁴⁾ | | dB |
| Crosstalk | Between the two video channels | | | -50 | -40 | dB |

- (1) For internal input clock information, For more information, see the DSS chapter of the *OMAP35x Technical Reference Manual (TRM)* [literature number [SPRUJ98](#)].
- (2) The differential gain and phase value is for dc coupling. Note that there is degradation for the ac coupling.
- (3) The SNR value is for dc coupling. Note that there is a 6-dB degradation for ac coupling.
- (4) The PSRR value is for dc coupling. Note that there is a 10-dB degradation for ac coupling.

5.3 Analog Supply (vdda_dac) Noise Requirements

In order to assure 10-bit accuracy of the DAC analog output, the analog supply vdda_dac has to meet the noise requirements stated in this section.

The DAC Power Supply Rejection Ratio is defined as the relative variation of the full-scale output current divided by the supply variation. Thus, it is expressed in percentage of Full-Scale Range (FSR) per volt of

$$PSRR_{DAC} = \frac{100 \cdot \frac{\Delta I_{OUT}}{I_{OUTFS}}}{V_{AC}} \quad \left[\frac{\% FSR}{V} \right]$$

supply variation as shown in the following equation:

Depending on frequency, the PSRR is defined in [Table 5-4](#).

Table 5-4. Video DAC – Power Supply Rejection Ratio

| Supply Noise Frequency | PSRR % FSR/V |
|------------------------|--|
| 0 to 100 kHz | 1 |
| > 100 kHz | The rejection decreases 20 dB/dec. Example: at 1 MHz the PSRR is 10% of FSR/V |

A graphic representation is shown in [Figure 5-2](#).

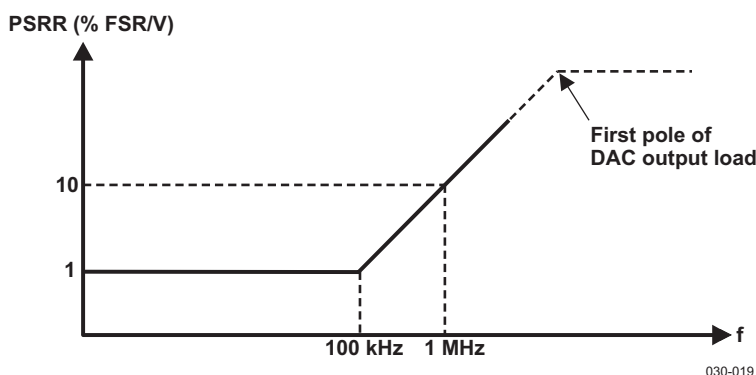

Figure 5-2. Video DAC – Power Supply Rejection Ratio

To ensure that the DAC SFDR specification is met, the PSRR values and the clock jitter requirements translate to the following limits on vdda_dac (for the Video DAC).

The maximum peak-to-peak noise on vdda (ripple) is defined in [Table 5-5](#):

Table 5-5. Video DAC – Maximum Peak-to-Peak Noise on vdda_dac

| Tone Frequency | Maximum Peak-to-Peak Noise on vdda_dac |
|----------------|---|
| 0 to 100 kHz | < 30 mVpp |
| > 100 kHz | Decreases 20 dB/dec. Example: at 1 MHz the maximum is 3 mVpp |

The maximum noise spectral density (white noise) is defined in [Table 5-6](#):

Table 5-6. Video DAC – Maximum Noise Spectral Density

| Supply Noise Bandwidth | Maximum Supply Noise Density |
|------------------------|---|
| 0 to 100 kHz | < 20 $\mu\text{V} / \sqrt{\text{Hz}}$ |
| > 100 kHz | Decreases 20 dB/dec. Example: at 1 MHz the maximum noise density is 2 $\mu\text{V} / \sqrt{\text{Hz}}$ |

Because the DAC PSRR deteriorates at a rate of 20 dB/dec after 100 kHz, it is highly recommended to have vdda_dac low pass filtered (proper decoupling) (see the illustrated application: [Section 5.4, External Component Value Choice](#)).

5.4 External Component Value Choice

The full-scale output voltage V_{OUTMAX} is regulated by the reference amplifier, and is set by an internal resistor R_{SET} . I_{OUTMAX} can be expressed as:

$$I_{OUTMAX} = I_{REF} / 8 * (63 + 15/16)$$

Where:

$$V_{REF} = 0.55V$$

$$I_{REF} = V_{REF} / (2 * R_{SET})$$

The output current I_{OUT} appearing at DAC output is a function of both the input code and I_{OUTMAX} and can be expressed as:

$$I_{OUT} = (DAC_CODE/1023) * I_{OUTMAX}$$

Where:

DAC_CODE = 0 to 1023 is the DAC input code in decimal.

The output voltage is:

$$V_{OUT} = I_{OUT} * N * R_{CABLE}$$

Where:

(N = amplifier gain = 21)

$R_{CABLE} = 75 \Omega$ (cable typical impedance)

The TV-out buffer requires a per channel external resistors: $R_{OUT1/2}$. The equation below can be used to select different resistor values (if necessary):

$$R_{OUT} = (N+1) R_{CABLE} = 1650 \Omega$$

Recommended parameter values are:

Table 5-7. Video DAC – Recommended External Components Values

| | Recommended Value | UNIT |
|--------------|-------------------|----------|
| C_{BG} | 100 | nF |
| $R_{OUT1/2}$ | 1650 | Ω |

In order to limit the reference noise bandwidth and to suppress transients on V_{REF} , it is necessary to connect a large decoupling capacitor (C_{BG}) between the tv_vref and vssa_dac pins.

6 TIMING REQUIREMENTS AND SWITCHING CHARACTERISTICS

6.1 Timing Test Conditions

All timing requirements and switching characteristics are valid over the recommended operating conditions of [Table 3-3](#), unless otherwise specified.

6.2 Interface Clock Specifications

6.2.1 Interface Clock Terminology

The Interface clock is used at the system level to sequence the data and/or control transfers accordingly with the interface protocol.

6.2.2 Interface Clock Frequency

The two interface clock characteristics are:

- The maximum clock frequency
- The maximum operating frequency

The interface clock frequency documented in this document is the maximum clock frequency, which corresponds to the maximum frequency programmable on this output clock. This frequency defines the maximum limit supported by the OMAP3530/25 IC and doesn't take into account any system consideration (PCB, peripherals).

The system designer will have to consider these system considerations and OMAP3530/25 IC timings characteristics as well, to define properly the maximum operating frequency, which corresponds to the maximum frequency supported to transfer the data on this interface.

6.2.3 Clock Jitter Specifications

Jitter is a phase noise, which may alter different characteristics of a clock signal. The jitter specified in this document is the time difference between the typical cycle period and the actual cycle period affected by noise sources on the clock. The cycle (or period) jitter terminology identifies this type of jitter.

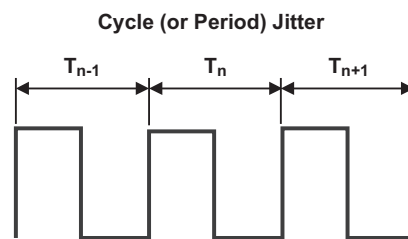

Max. Cycle Jitter = Max (T_i)

Min. Cycle Jitter = Min (T_i)

Jitter Standard Deviation (or rms Jitter) = Standard Deviation (T_i)

030-020

Figure 6-1. Cycle (or Period) Jitter

6.2.4 Clock Duty Cycle Error

The duty cycle error is the ratio between either the high-level pulse duration or the low-level pulse duration and the cycle time of a clock signal.

6.3 Timing Parameters

The timing parameter symbols used in the timing requirement and switching characteristic tables are created in accordance with JEDEC Standard 100. To shorten the symbols, some pin names and other related terminologies have been abbreviated as follows:

Table 6-1. Timing Parameters

| LOWERCASE SUBSCRIPTS | |
|----------------------|--|
| Symbols | Parameter |
| c | Cycle time (period) |
| d | Delay time |
| dis | Disable time |
| en | Enable time |
| h | Hold time |
| su | Setup time |
| START | Start bit |
| t | Transition time |
| v | Valid time |
| w | Pulse duration (width) |
| X | Unknown, changing, or don't care level |
| H | High |
| L | Low |
| V | Valid |
| IV | Invalid |
| AE | Active Edge |
| FE | First Edge |
| LE | Last Edge |
| Z | High impedance |

6.4 External Memory Interfaces

The OMAP3530/25 processor includes the following external memory interfaces:

- General-purpose memory controller (GPMC)
- SDRAM controller (SDRC)

6.4.1 General-Purpose Memory Controller (GPMC)

The GPMC is the OMAP3530/25 unified memory controller used to interface external memory devices such as:

- Asynchronous SRAM-like memories and ASIC devices
- Asynchronous page mode and synchronous burst NOR flash
- NAND flash

6.4.1.1 GPMC/NOR Flash Interface Synchronous Timing

Table 6-3 and Table 6-4 assume testing over the recommended operating conditions (see Figure 6-2 through Figure 6-5) and electrical characteristic conditions.

Table 6-2. GPMC/NOR Flash Synchronous Mode Timing Conditions

| TIMING CONDITION PARAMETER | | VALUE | UNIT |
|----------------------------|-------------------------|-------|------|
| Input Conditions | | | |
| t_R | Input signal rise time | 1.8 | ns |
| t_F | Input signal fall time | 1.8 | ns |
| Output Conditions | | | |
| C_{LOAD} | Output load capacitance | 15.94 | pF |

Table 6-3. GPMC/NOR Flash Interface Timing Requirements – Synchronous Mode⁽¹⁾

| NO. | PARAMETER | | OPP3 | | OPP2 | | OPP1 ⁽²⁾ | | UNIT |
|-----|----------------------|--|------|-----|------|-----|---------------------|-----|------|
| | | | MIN | MAX | MIN | MAX | MIN | MAX | |
| F12 | $t_{su(DV-CLKH)}$ | Setup time, read gpmc_d[15:0] valid before gpmc_clk high | 1.9 | | 1.9 | | 3.2 | | ns |
| F13 | $t_h(CLKH-DV)$ | Hold time, read gpmc_d[15:0] valid after gpmc_clk high | 1.9 | | 1.9 | | 1.9 | | ns |
| F21 | $t_{su(WAITV-CLKH)}$ | Setup time, gpmc_waitx ⁽³⁾ valid before gpmc_clk high | 1.9 | | 1.9 | | 3.2 | | ns |
| F22 | $t_h(CLKH-WAITV)$ | Hold Time, gpmc_waitx ⁽³⁾ valid after gpmc_clk high | 2.5 | | 2.5 | | 2.5 | | ns |

(1) For VDD2 (vdd_core) OPP voltages, see Table 3-3, Recommended Operating Conditions.

(2) Cannot boot in OPP1. If OPP1 is desired, boot in higher OPP then switch to OPP1.

(3) Wait monitoring support is limited to a WaitMonitoringTime value > 0. For a full description of wait monitoring feature, see the OMAP35x Technical Reference Manual (literature number [SPRU988](#)).

Table 6-4. GPMC/NOR Flash Interface Switching Characteristics – Synchronous Mode

| NO. | PARAMETER | | 1.15 V | | 1.0 V | | 0.9 V | | UNIT |
|-----|---------------|---|-----------------------|-----------------------|-----------------------|-----------------------|-----------------------|-----------------------|------|
| | | | MIN | MAX | MIN | MAX | MIN | MAX | |
| F0 | $t_c(CLK)$ | Cycle time ⁽¹⁵⁾ , output clock gpmc_clk period | 10 | | 12.05 | | 25 | | ns |
| F1 | $t_w(CLKH)$ | Typical pulse duration, output clock gpmc_clk high | 0.5 P ⁽¹²⁾ | 0.5 P ⁽¹²⁾ | 0.5 P ⁽¹²⁾ | 0.5 P ⁽¹²⁾ | 0.5 P ⁽¹²⁾ | 0.5 P ⁽¹²⁾ | ns |
| F1 | $t_w(CLKL)$ | Typical pulse duration, output clock gpmc_clk low | 0.5 P ⁽¹²⁾ | 0.5 P ⁽¹²⁾ | 0.5 P ⁽¹²⁾ | 0.5 P ⁽¹²⁾ | 0.5 P ⁽¹²⁾ | 0.5 P ⁽¹²⁾ | ns |
| | $t_{dc}(CLK)$ | Duty cycle error, output clk gpmc_clk | –500 | 500 | –602 | 602 | –1250 | 1250 | ps |

Table 6-4. GPMC/NOR Flash Interface Switching Characteristics – Synchronous Mode (continued)

| NO. | PARAMETER | | 1.15 V | | 1.0 V | | 0.9 V | | UNIT |
|-----|-----------------------------|--|-------------------------|-------------------------|-------------------------|-------------------------|-------------------------|-------------------------|------|
| | | | MIN | MAX | MIN | MAX | MIN | MAX | |
| | $t_{j(\text{CLK})}$ | Jitter standard deviation ⁽¹⁶⁾ , output clock gpmc_clk | | 33.3 | | 33.3 | | 33.3 | ps |
| | $t_{R(\text{CLK})}$ | Rise time, output clock gpmc_clk | | 1.6 | | 2 | | 2 | ns |
| | $t_{F(\text{CLK})}$ | Fall time, output clock gpmc_clk | | 1.6 | | 2 | | 2 | ns |
| | $t_{R(\text{DO})}$ | Rise time, output data | | 2 | | 2 | | 2 | ns |
| | $t_{F(\text{DO})}$ | Fall time, output data | | 2 | | 2 | | 2 | ns |
| F2 | $t_{d(\text{CLKH-nCSV})}$ | Delay time, gpmc_clk rising edge to gpmc_ncsx ⁽¹¹⁾ transition | F ⁽⁶⁾ – 1.9 | F ⁽⁶⁾ + 3.3 | F ⁽⁶⁾ – 1.8 | F ⁽⁶⁾ + 4.1 | F ⁽⁶⁾ – 2.6 | F ⁽⁶⁾ + 4.9 | ns |
| F3 | $t_{d(\text{CLKH-nCSIV})}$ | Delay time, gpmc_clk rising edge to gpmc_ncsx ⁽¹¹⁾ invalid | E ⁽⁵⁾ – 1.9 | E ⁽⁵⁾ + 3.3 | E ⁽⁵⁾ – 1.8 | E ⁽⁵⁾ + 4.1 | E ⁽⁵⁾ – 2.6 | E ⁽⁵⁾ + 4.9 | ns |
| F4 | $t_{d(\text{ADDV-CLK})}$ | Delay time, address bus valid to gpmc_clk first edge | B ⁽²⁾ – 4.1 | B ⁽²⁾ + 2.1 | B ⁽²⁾ – 4.1 | B ⁽²⁾ + 2.1 | B ⁽²⁾ – 4.9 | B ⁽²⁾ + 2.6 | ns |
| F5 | $t_{d(\text{CLKH-ADDIV})}$ | Delay time, gpmc_clk rising edge to gpmc_a[16:1] invalid | –2.1 | | –2.1 | | –2.6 | | ns |
| F6 | $t_{d(\text{nBEV-CLK})}$ | Delay time, gpmc_nbe0_cle, gpmc_nbe1 valid to gpmc_clk first edge | B ⁽²⁾ – 1.1 | B ⁽²⁾ + 2.1 | B ⁽²⁾ – 0.9 | B ⁽²⁾ + 1.9 | B ⁽²⁾ – 2.6 | B ⁽²⁾ + 2.6 | ns |
| F7 | $t_{d(\text{CLKH-nBEIV})}$ | Delay time, gpmc_clk rising edge to gpmc_nbe0_cle, gpmc_nbe1 invalid | D ⁽⁴⁾ – 2.1 | D ⁽⁴⁾ + 1.1 | D ⁽⁴⁾ – 1.9 | D ⁽⁴⁾ + 0.9 | D ⁽⁴⁾ – 2.6 | D ⁽⁴⁾ + 2.6 | ns |
| F8 | $t_{d(\text{CLKH-nADV})}$ | Delay time, gpmc_clk rising edge to gpmc_nadv_ale transition | G ⁽⁷⁾ – 1.9 | G ⁽⁷⁾ + 4.1 | G ⁽⁷⁾ – 2.1 | G ⁽⁷⁾ + 4.1 | G ⁽⁷⁾ – 2.6 | G ⁽⁷⁾ + 4.9 | ns |
| F9 | $t_{d(\text{CLKH-nADVIV})}$ | Delay time, gpmc_clk rising edge to gpmc_nadv_ale invalid | D ⁽⁴⁾ – 1.9 | D ⁽⁴⁾ + 4.1 | D ⁽⁴⁾ – 2.1 | D ⁽⁴⁾ + 4.1 | D ⁽⁴⁾ – 2.6 | D ⁽⁴⁾ + 4.9 | ns |
| F10 | $t_{d(\text{CLKH-nOE})}$ | Delay time, gpmc_clk rising edge to gpmc_noe transition | H ⁽⁸⁾ – 2.1 | H ⁽⁸⁾ + 2.1 | H ⁽⁸⁾ – 2.1 | H ⁽⁸⁾ + 2.1 | H ⁽⁸⁾ – 2.6 | H ⁽⁸⁾ + 4.9 | ns |
| F11 | $t_{d(\text{CLKH-nOEIV})}$ | Delay time, gpcm rising edge to gpmc_noe invalid | E ⁽⁵⁾ – 2.1 | E ⁽⁵⁾ + 2.1 | E ⁽⁵⁾ – 2.1 | E ⁽⁵⁾ + 2.1 | E ⁽⁵⁾ – 2.6 | E ⁽⁵⁾ + 4.9 | ns |
| F14 | $t_{d(\text{CLKH-nWE})}$ | Delay time, gpmc_clk rising edge to gpmc_nwe transition | I ⁽⁹⁾ – 1.9 | I ⁽⁹⁾ + 4.1 | I ⁽⁹⁾ – 2.1 | I ⁽⁹⁾ + 4.1 | I ⁽⁹⁾ – 2.6 | I ⁽⁹⁾ + 4.9 | ns |
| F15 | $t_{d(\text{CLKH-Data})}$ | Delay time, gpmc_clk rising edge to data bus transition | J ⁽¹⁰⁾ – 2.1 | J ⁽¹⁰⁾ + 1.1 | J ⁽¹⁰⁾ – 1.9 | J ⁽¹⁰⁾ + 0.9 | J ⁽¹⁰⁾ – 2.6 | J ⁽¹⁰⁾ + 2.6 | ns |
| F17 | $t_{d(\text{CLKH-nBE})}$ | Delay time, gpmc_clk rising edge to gpmc_nbex_cle transition | J ⁽¹⁰⁾ – 2.1 | J ⁽¹⁰⁾ + 1.1 | J ⁽¹⁰⁾ – 1.9 | J ⁽¹⁰⁾ + 0.9 | J ⁽¹⁰⁾ – 2.6 | J ⁽¹⁰⁾ + 2.6 | ns |
| F18 | $t_{W(\text{nCSV})}$ | Pulse duration, gpmc_ncsx ⁽¹¹⁾ low | Read | A ⁽¹⁾ | | A ⁽¹⁾ | | A ⁽¹⁾ | ns |
| | | | Write | A ⁽¹⁾ | | A ⁽¹⁾ | | A ⁽¹⁾ | ns |
| F19 | $t_{W(\text{nBEV})}$ | Pulse duration, gpmc_nbe0_cle, gpmc_nbe1 low | Read | C ⁽³⁾ | | C ⁽³⁾ | | C ⁽³⁾ | ns |
| | | | Write | C ⁽³⁾ | | C ⁽³⁾ | | C ⁽³⁾ | ns |
| F20 | $t_{W(\text{nADV})}$ | Pulse duration, gpmc_nadv_ale low | Read | K ⁽¹³⁾ | | K ⁽¹³⁾ | | K ⁽¹³⁾ | ns |
| | | | Write | K ⁽¹³⁾ | | K ⁽¹³⁾ | | K ⁽¹³⁾ | ns |

Table 6-4. GPMC/NOR Flash Interface Switching Characteristics – Synchronous Mode (continued)

| NO. | PARAMETER | | 1.15 V | | 1.0 V | | 0.9 V | | UNIT |
|-----|----------------------------|---|------------------|------------------|------------------|------------------|------------------|------------------|------|
| | | | MIN | MAX | MIN | MAX | MIN | MAX | |
| F23 | $t_{d(\text{CLKH-IODIR})}$ | Delay time, gpmc_clk rising edge to gpmc_io_dir high (IN direction) | $H^{(8)} - 2.1$ | $H^{(8)} + 4.1$ | $H^{(8)} - 2.1$ | $H^{(8)} + 4.1$ | $H^{(8)} - 2.6$ | $H^{(8)} + 4.9$ | ns |
| F24 | $t_{d(\text{CLKH-IODIV})}$ | Delay time, gpmc_clk rising edge to gpmc_io_dir low (OUT direction) | $M^{(17)} - 2.1$ | $M^{(17)} + 4.1$ | $M^{(17)} - 2.1$ | $M^{(17)} + 4.1$ | $M^{(17)} - 2.6$ | $M^{(17)} + 4.9$ | ns |

- (1) **For single read:** $A = (\text{CSRdOffTime} - \text{CSOnTime}) * (\text{TimeParaGranularity} + 1) * \text{GPMC_FCLK period}$
For burst read: $A = (\text{CSRdOffTime} - \text{CSOnTime} + (n - 1) * \text{PageBurstAccessTime}) * (\text{TimeParaGranularity} + 1) * \text{GPMC_FCLK period}$
For burst write: $A = (\text{CSWrOffTime} - \text{CSOnTime} + (n - 1) * \text{PageBurstAccessTime}) * (\text{TimeParaGranularity} + 1) * \text{GPMC_FCLK period}$
with n being the page burst access number.
- (2) $B = \text{ClkActivationTime} * \text{GPMC_FCLK}$
- (3) **For single read:** $C = \text{RdCycleTime} * (\text{TimeParaGranularity} + 1) * \text{GPMC_FCLK}$
For burst read: $C = (\text{RdCycleTime} + (n - 1) * \text{PageBurstAccessTime}) * (\text{TimeParaGranularity} + 1) * \text{GPMC_FCLK}$
For burst write: $C = (\text{WrCycleTime} + (n - 1) * \text{PageBurstAccessTime}) * (\text{TimeParaGranularity} + 1) * \text{GPMC_FCLK}$ with n being the page burst access number.
- (4) **For single read:** $D = (\text{RdCycleTime} - \text{AccessTime}) * (\text{TimeParaGranularity} + 1) * \text{GPMC_FCLK}$
For burst read: $D = (\text{RdCycleTime} - \text{AccessTime}) * (\text{TimeParaGranularity} + 1) * \text{GPMC_FCLK}$
For burst write: $D = (\text{WrCycleTime} - \text{AccessTime}) * (\text{TimeParaGranularity} + 1) * \text{GPMC_FCLK}$
- (5) **For single read:** $E = (\text{CSRdOffTime} - \text{AccessTime}) * (\text{TimeParaGranularity} + 1) * \text{GPMC_FCLK}$
For burst read: $E = (\text{CSRdOffTime} - \text{AccessTime}) * (\text{TimeParaGranularity} + 1) * \text{GPMC_FCLK}$
For burst write: $E = (\text{CSWrOffTime} - \text{AccessTime}) * (\text{TimeParaGranularity} + 1) * \text{GPMC_FCLK}$
- (6) **For nCS falling edge (CS activated):**
- **Case GpmcFCLKDivider = 0:**
 - $F = 0.5 * \text{CSExtraDelay} * \text{GPMC_FCLK}$
 - **Case GpmcFCLKDivider = 1:**
 - $F = 0.5 * \text{CSExtraDelay} * \text{GPMC_FCLK}$ if (ClkActivationTime and CSOnTime are odd) or (ClkActivationTime and CSOnTime are even)
 - $F = (1 + 0.5 * \text{CSExtraDelay}) * \text{GPMC_FCLK}$ otherwise
 - **Case GpmcFCLKDivider = 2:**
 - $F = 0.5 * \text{CSExtraDelay} * \text{GPMC_FCLK}$ if ((CSOnTime – ClkActivationTime) is a multiple of 3)
 - $F = (1 + 0.5 * \text{CSExtraDelay}) * \text{GPMC_FCLK}$ if ((CSOnTime – ClkActivationTime – 1) is a multiple of 3)
 - $F = (2 + 0.5 * \text{CSExtraDelay}) * \text{GPMC_FCLK}$ if ((CSOnTime – ClkActivationTime – 2) is a multiple of 3)
- (7) **For ADV falling edge (ADV activated):**
- **Case GpmcFCLKDivider = 0:**
 - $G = 0.5 * \text{ADVExtraDelay} * \text{GPMC_FCLK}$
 - **Case GpmcFCLKDivider = 1:**
 - $G = 0.5 * \text{ADVExtraDelay} * \text{GPMC_FCLK}$ if (ClkActivationTime and ADVOnTime are odd) or (ClkActivationTime and ADVOnTime are even)
 - $G = (1 + 0.5 * \text{ADVExtraDelay}) * \text{GPMC_FCLK}$ otherwise
 - **Case GpmcFCLKDivider = 2:**
 - $G = 0.5 * \text{ADVExtraDelay} * \text{GPMC_FCLK}$ if ((ADVOnTime – ClkActivationTime) is a multiple of 3)
 - $G = (1 + 0.5 * \text{ADVExtraDelay}) * \text{GPMC_FCLK}$ if ((ADVOnTime – ClkActivationTime – 1) is a multiple of 3)
 - $G = (2 + 0.5 * \text{ADVExtraDelay}) * \text{GPMC_FCLK}$ if ((ADVOnTime – ClkActivationTime – 2) is a multiple of 3)
- For ADV rising edge (ADV deactivated) in Reading mode:**
- **Case GpmcFCLKDivider = 0:**
 - $G = 0.5 * \text{ADVExtraDelay} * \text{GPMC_FCLK}$
 - **Case GpmcFCLKDivider = 1:**
 - $G = 0.5 * \text{ADVExtraDelay} * \text{GPMC_FCLK}$ if (ClkActivationTime and ADVrOffTime are odd) or (ClkActivationTime and ADVrOffTime are even)
 - $G = (1 + 0.5 * \text{ADVExtraDelay}) * \text{GPMC_FCLK}$ otherwise
 - **Case GpmcFCLKDivider = 2:**
 - $G = 0.5 * \text{ADVExtraDelay} * \text{GPMC_FCLK}$ if ((ADVrOffTime – ClkActivationTime) is a multiple of 3)
 - $G = (1 + 0.5 * \text{ADVExtraDelay}) * \text{GPMC_FCLK}$ if ((ADVrOffTime – ClkActivationTime – 1) is a multiple of 3)
 - $G = (2 + 0.5 * \text{ADVExtraDelay}) * \text{GPMC_FCLK}$ if ((ADVrOffTime – ClkActivationTime – 2) is a multiple of 3)
- For ADV rising edge (ADV deactivated) in Writing mode:**
- **Case GpmcFCLKDivider = 0:**
 - $G = 0.5 * \text{ADVExtraDelay} * \text{GPMC_FCLK}$
 - **Case GpmcFCLKDivider = 1:**
 - $G = 0.5 * \text{ADVExtraDelay} * \text{GPMC_FCLK}$ if (ClkActivationTime and ADVWrOffTime are odd) or (ClkActivationTime and ADVWrOffTime are even)
 - $G = (1 + 0.5 * \text{ADVExtraDelay}) * \text{GPMC_FCLK}$ otherwise
 - **Case GpmcFCLKDivider = 2:**

- $G = 0.5 * ADVExtraDelay * GPMC_FCLK$ if $((ADVWrOffTime - ClkActivationTime)$ is a multiple of 3)
- $G = (1 + 0.5 * ADVExtraDelay) * GPMC_FCLK$ if $((ADVWrOffTime - ClkActivationTime - 1)$ is a multiple of 3)
- $G = (2 + 0.5 * ADVExtraDelay) * GPMC_FCLK$ if $((ADVWrOffTime - ClkActivationTime - 2)$ is a multiple of 3)

(8) For OE falling edge (OE activated) / IO DIR rising edge (Data Bus input direction):

- **Case GpmcFCLKDivider = 0:**
 - $H = 0.5 * OEEExtraDelay * GPMC_FCLK$
- **Case GpmcFCLKDivider = 1:**
 - $H = 0.5 * OEEExtraDelay * GPMC_FCLK$ if $(ClkActivationTime$ and $OEOntime$ are odd) or $(ClkActivationTime$ and $OEOntime$ are even)
 - $H = (1 + 0.5 * OEEExtraDelay) * GPMC_FCLK$ otherwise
- **Case GpmcFCLKDivider = 2:**
 - $H = 0.5 * OEEExtraDelay * GPMC_FCLK$ if $((OEOntime - ClkActivationTime)$ is a multiple of 3)
 - $H = (1 + 0.5 * OEEExtraDelay) * GPMC_FCLK$ if $((OEOntime - ClkActivationTime - 1)$ is a multiple of 3)
 - $H = (2 + 0.5 * OEEExtraDelay) * GPMC_FCLK$ if $((OEOntime - ClkActivationTime - 2)$ is a multiple of 3)

For OE rising edge (OE deactivated):

- **GpmcFCLKDivider = 0:**
 - $H = 0.5 * OEEExtraDelay * GPMC_FCLK$
- **Case GpmcFCLKDivider = 1:**
 - $H = 0.5 * OEEExtraDelay * GPMC_FC$ if $(ClkActivationTime$ and $OEOffTime$ are odd) or $(ClkActivationTime$ and $OEOffTime$ are even)
 - $H = (1 + 0.5 * OEEExtraDelay) * GPMC_FCLK$ otherwise
- **Case GpmcFCLKDivider = 2:**
 - $H = 0.5 * OEEExtraDelay * GPMC_FCLK$ if $((OEOffTime - ClkActivationTime)$ is a multiple of 3)
 - $H = (1 + 0.5 * OEEExtraDelay) * GPMC_FCLK$ if $((OEOffTime - ClkActivationTime - 1)$ is a multiple of 3)
 - $H = (2 + 0.5 * OEEExtraDelay) * GPMC_FCLK$ if $((OEOffTime - ClkActivationTime - 2)$ is a multiple of 3)

(9) For WE falling edge (WE activated):

- **Case GpmcFCLKDivider = 0:**
 - $I = 0.5 * WEEExtraDelay * GPMC_FCLK$
- **Case GpmcFCLKDivider = 1:**
 - $I = 0.5 * WEEExtraDelay * GPMC_FCLK$ if $(ClkActivationTime$ and $WEOnTime$ are odd) or $(ClkActivationTime$ and $WEOnTime$ are even)
 - $I = (1 + 0.5 * WEEExtraDelay) * GPMC_FCLK$ otherwise
- **Case GpmcFCLKDivider = 2:**
 - $I = 0.5 * WEEExtraDelay * GPMC_FCLK$ if $((WEOnTime - ClkActivationTime)$ is a multiple of 3)
 - $I = (1 + 0.5 * WEEExtraDelay) * GPMC_FCLK$ if $((WEOnTime - ClkActivationTime - 1)$ is a multiple of 3)
 - $I = (2 + 0.5 * WEEExtraDelay) * GPMC_FCLK$ if $((WEOnTime - ClkActivationTime - 2)$ is a multiple of 3)

For WE rising edge (WE deactivated):

- **Case GpmcFCLKDivider = 0:**
 - $I = 0.5 * WEEExtraDelay * GPMC_FCLK$
- **Case GpmcFCLKDivider = 1:**
 - $I = 0.5 * WEEExtraDelay * GPMC_FCLK$ if $(ClkActivationTime$ and $WEOffTime$ are odd) or $(ClkActivationTime$ and $WEOffTime$ are even)
 - $I = (1 + 0.5 * WEEExtraDelay) * GPMC_FCLK$ otherwise
- **Case GpmcFCLKDivider = 2:**
 - $I = 0.5 * WEEExtraDelay * GPMC_FCLK$ if $((WEOffTime - ClkActivationTime)$ is a multiple of 3)
 - $I = (1 + 0.5 * WEEExtraDelay) * GPMC_FCLK$ if $((WEOffTime - ClkActivationTime - 1)$ is a multiple of 3)
 - $I = (2 + 0.5 * WEEExtraDelay) * GPMC_FCLK$ if $((WEOffTime - ClkActivationTime - 2)$ is a multiple of 3)

(10) $J = GPMC_FCLK$ period

(11) In $gpmc_ncsx$, x is equal to 0, 1, 2, 3, 4, 5, 6, or 7. In $gpmc_waitx$, x is equal to 0, 1, 2, or 3.

(12) $P = gpmc_clk$ period

(13) **For read:** $K = (ADVRdOffTime - ADVOnTime) * (TimeParaGranularity + 1) * GPMC_FCLK$
For write: $K = (ADVWrOffTime - ADVOnTime) * (TimeParaGranularity + 1) * GPMC_FCLK$

(14) $GPMC_FCLK$ is General-Purpose Memory Controller internal functional clock.

(15) Related to the $gpmc_clk$ output clock maximum and minimum frequencies programmable in the I/F module by setting the $GPMC_CONFIG1_CSx$ configuration register bit field $GpmcFCLKDivider$.

(16) The jitter probability density can be approximated by a Gaussian function.

(17) $M = (RdCycleTime - AccessTime) * (TimeParaGranularity + 1) * GPMC_FCLK$

Above M parameter expression is given as one example of GPMC programming. IO DIR signal will go from IN to OUT after both $RdCycleTime$ and $BusTurnAround$ completion. Behavior of IO direction signal does depend on kind of successive Read/Write accesses performed to Memory and multiplexed or non-multiplexed memory addressing scheme, bus keeping feature enabled or not. IO DIR behavior is automatically handled by GPMC controller. For a full description of the $gpmc_io_dir$ feature, see the *OMAP35x Technical Reference Manual (TRM)* [literature number [SPRUF98](#)].

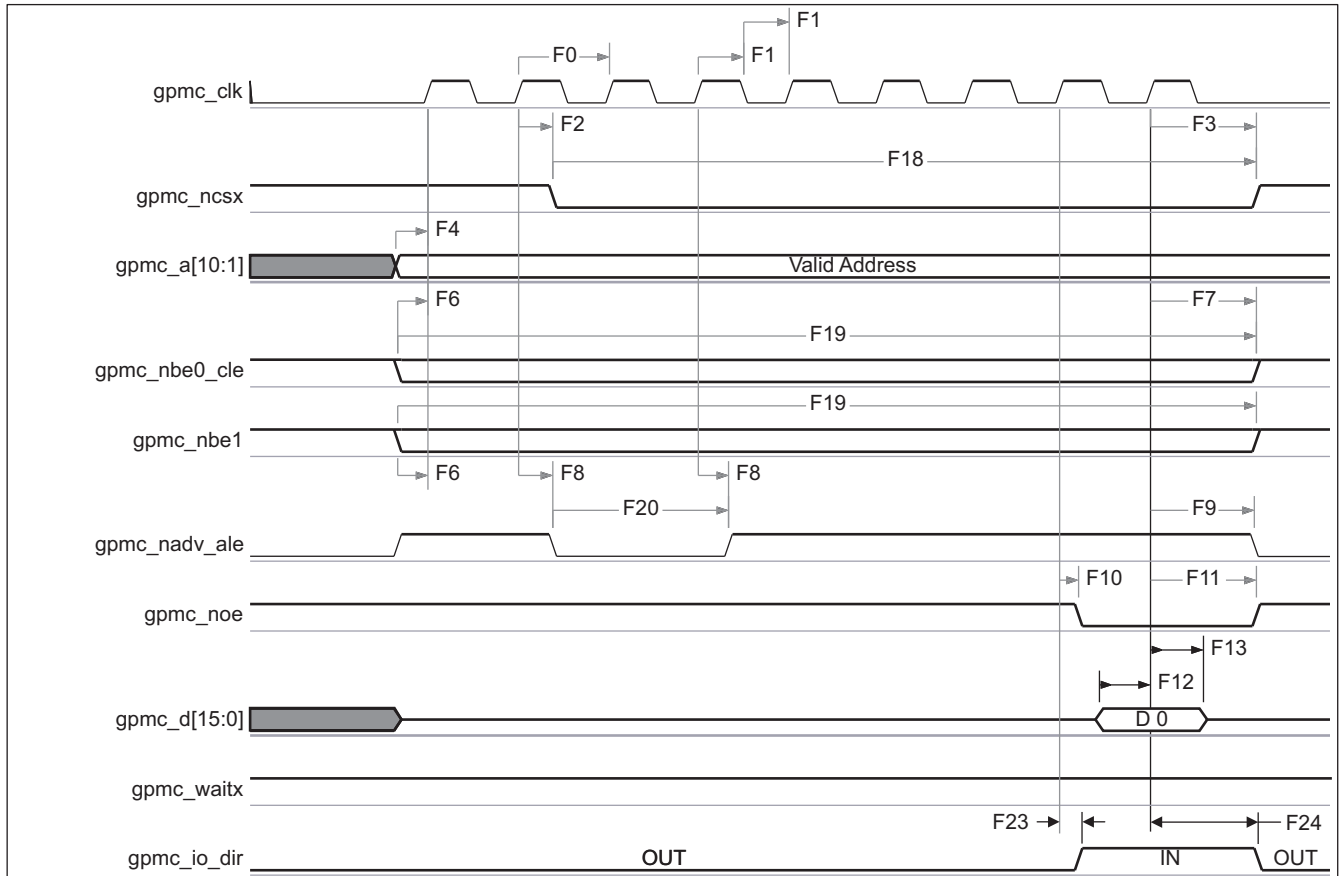

030-021

In gpmc_ncsx, x is equal to 0, 1, 2, 3, 4, 5, 6, or 7. In gpmc_waitx, x is equal to 0, 1, 2, or 3.

Figure 6-2. GPMC/NOR Flash – Synchronous Single Read – (GpmcFCLKDivider = 0)

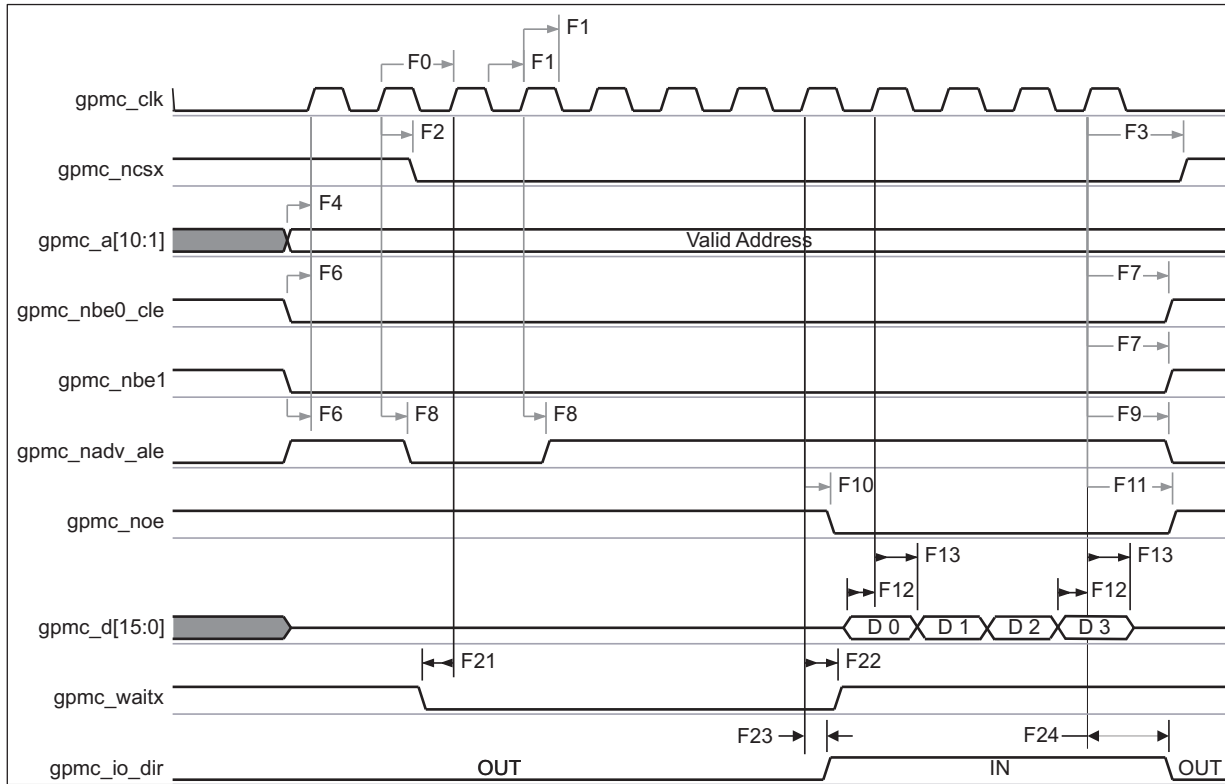

030-022

In gpmc_ncsx, x is equal to 0, 1, 2, 3, 4, 5, 6, or 7. In gpmc_waitx, x is equal to 0, 1, 2, or 3.

Figure 6-3. GPMC/NOR Flash – Synchronous Burst Read – 4x16-bit (GpmcFCLKDivider = 0)

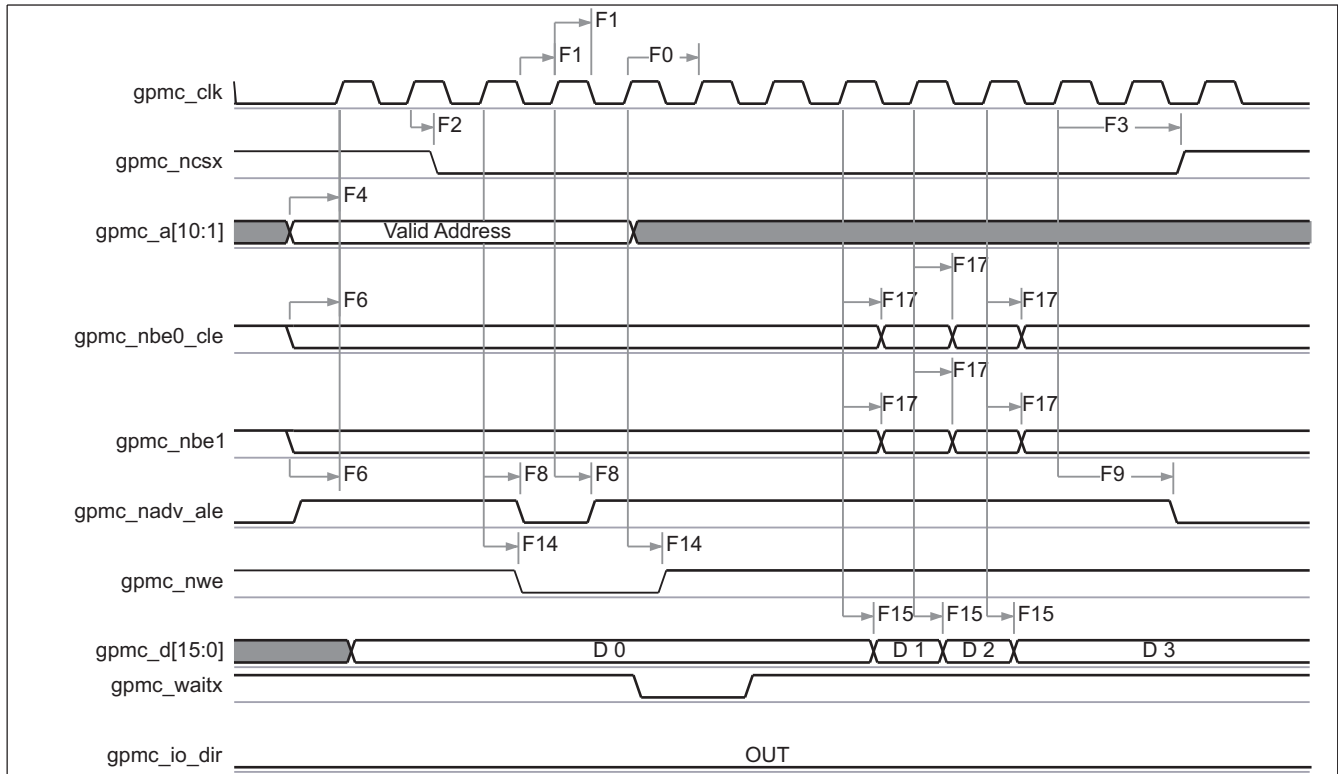

030-023

In gpmc_ncsx, x is equal to 0, 1, 2, 3, 4, 5, 6, or 7. In gpmc_waitx, x is equal to 0, 1, 2, or 3.

Figure 6-4. GPMC/NOR Flash – Synchronous Burst Write – (GpmcFCLKDivider = 0)

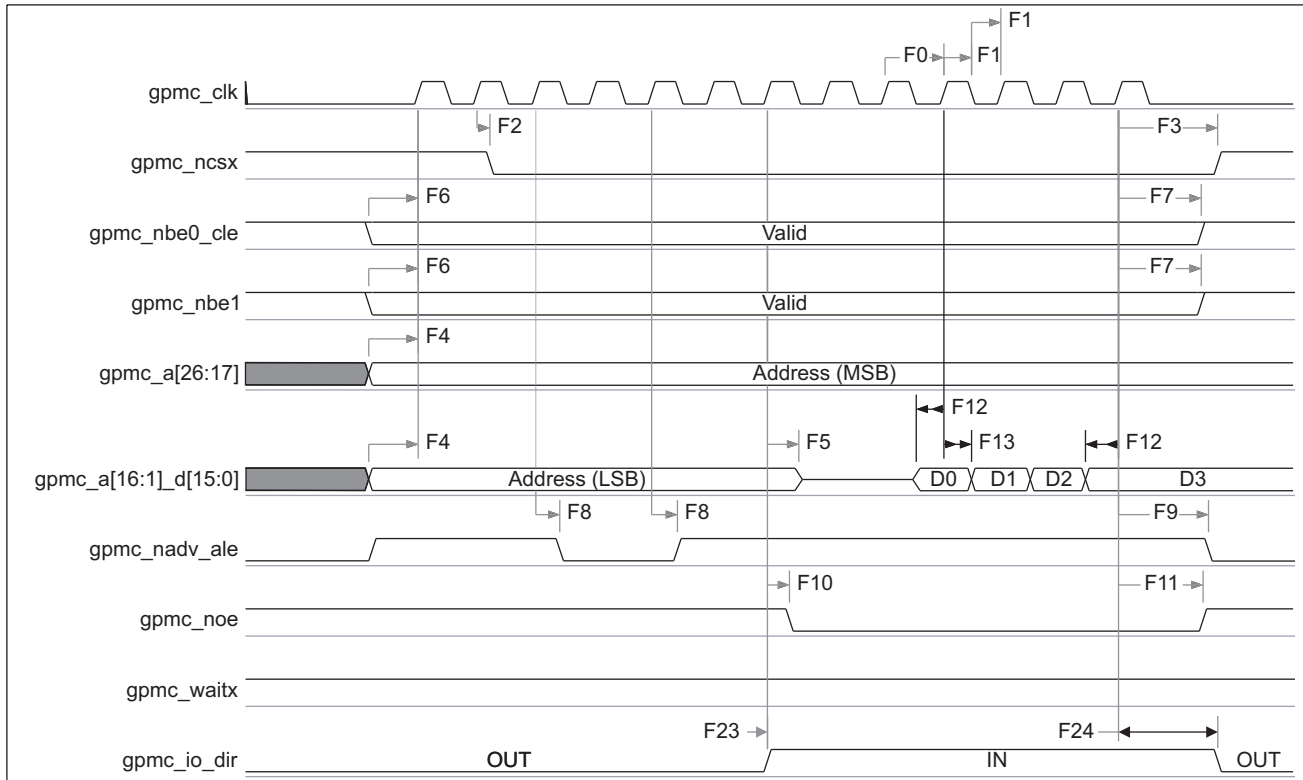

030-024

In gpmc_ncsx, x is equal to 0, 1, 2, 3, 4, 5, 6, or 7. In gpmc_waitx, x is equal to 0, 1, 2, or 3.

Figure 6-5. GPMC/Multiplexed NOR Flash – Synchronous Burst Read

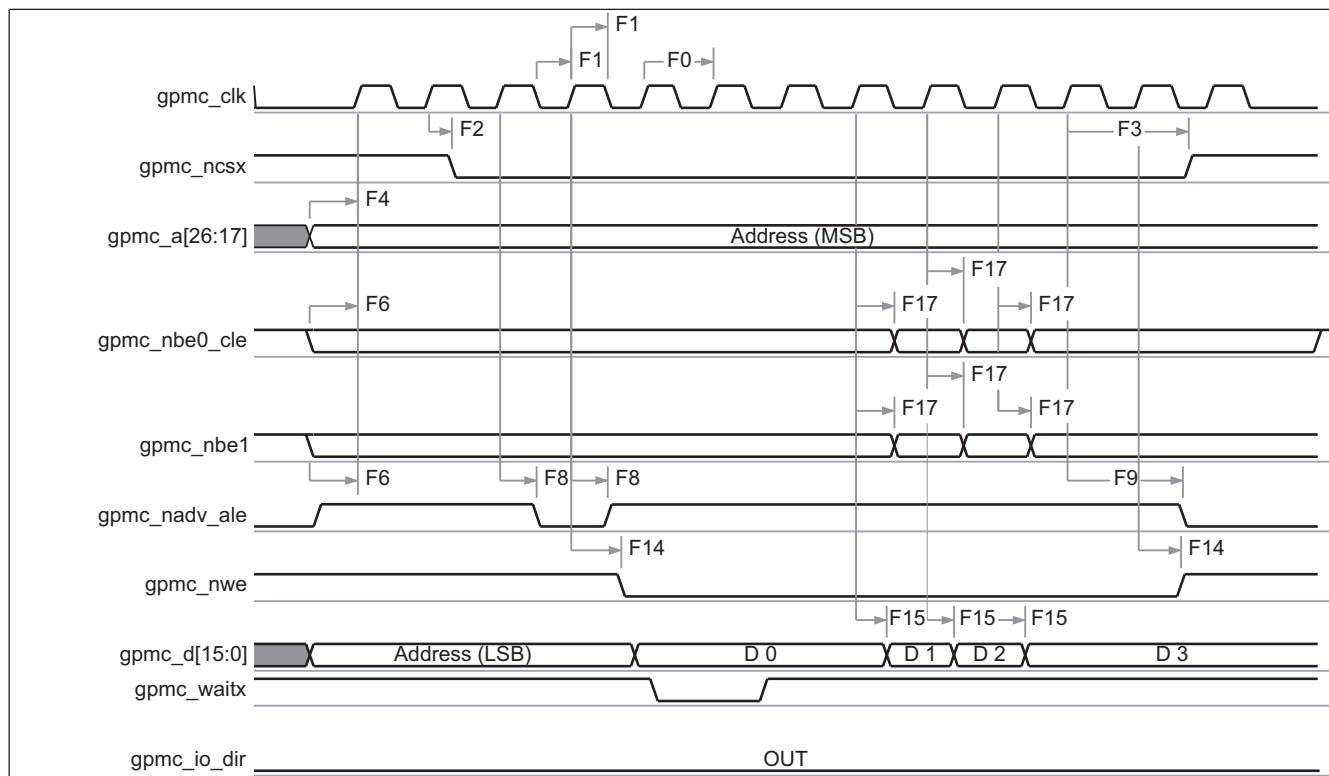

030-025

In gpmc_ncsx, x is equal to 0, 1, 2, 3, 4, 5, 6, or 7. In gpmc_waitx, x is equal to 0, 1, 2, or 3.

Figure 6-6. GPMC/Multiplexed NOR Flash – Synchronous Burst Write

6.4.1.2 GPMC/NOR Flash Interface Asynchronous Timing

Table 6-7 and Table 6-8 assume testing over the recommended operating conditions (see Figure 6-7 through Figure 6-12) and electrical characteristic conditions.

Table 6-5. GPMC/NOR Flash Asynchronous Mode Timing Conditions

| TIMING CONDITION PARAMETER | | VALUE | UNIT |
|----------------------------|-------------------------|-------|------|
| Input Conditions | | | |
| t_R | Input signal rise time | 1.8 | ns |
| t_F | Input signal fall time | 1.8 | ns |
| Output Conditions | | | |
| C_{LOAD} | Output load capacitance | 15.94 | pF |

Table 6-6. GPMC/NOR Flash Interface Asynchronous Timing – Internal Parameters⁽¹⁾⁽²⁾

| NO. | PARAMETER | 1.15 V | | 1.0 V | | 0.9 V | | UNIT |
|-----|---|--------|-----|-------|-----|-------|------|------|
| | | MIN | MAX | MIN | MAX | MIN | MAX | |
| F11 | Maximum output data generation delay from internal functional clock | | 6.5 | | 9.1 | | 13.7 | ns |
| F12 | Maximum input data capture delay by internal functional clock | | 4 | | 5.6 | | 8.1 | ns |
| F13 | Maximum device select generation delay from internal functional clock | | 6.5 | | 9.1 | | 13.7 | ns |

(1) The internal parameters table must be used to calculate Data Access Time stored in the corresponding CS register bit field.

(2) Internal parameters are referred to the GPMC functional internal clock which is not provided externally.

Table 6-6. GPMC/NOR Flash Interface Asynchronous Timing – Internal Parameters (continued)

| NO. | PARAMETER | 1.15 V | | 1.0 V | | 0.9 V | | UNIT |
|-----|---|--------|-----|-------|-----|-------|------|------|
| | | MIN | MAX | MIN | MAX | MIN | MAX | |
| FI4 | Maximum address generation delay from internal functional clock | | 6.5 | | 9.1 | | 13.7 | ns |
| FI5 | Maximum address valid generation delay from internal functional clock | | 6.5 | | 9.1 | | 13.7 | ns |
| FI6 | Maximum byte enable generation delay from internal functional clock | | 6.5 | | 9.1 | | 13.7 | ns |
| FI7 | Maximum output enable generation delay from internal functional clock | | 6.5 | | 9.1 | | 13.7 | ns |
| FI8 | Maximum write enable generation delay from internal functional clock | | 6.5 | | 9.1 | | 13.7 | ns |
| FI9 | Maximum functional clock skew | | 100 | | 170 | | 200 | ps |

Table 6-7. GPMC/NOR Flash Interface Timing Requirements – Asynchronous Mode

| NO. | PARAMETER | | 1.15 V | | 1.0 V | | 0.9 V | | UNIT |
|---------------------|-------------------------------|---|--------|------------------|-------|------------------|-------|------------------|------------------|
| | | | MIN | MAX | MIN | MAX | MIN | MAX | |
| FA5 ⁽¹⁾ | t _{acc(DAT)} | Data maximum access time | | H ⁽²⁾ | | H ⁽²⁾ | | H ⁽²⁾ | GPMC_FCLK cycles |
| FA20 ⁽³⁾ | t _{acc1-pgmode(DAT)} | Page mode successive data maximum access time | | P ⁽⁴⁾ | | P ⁽⁴⁾ | | P ⁽⁴⁾ | GPMC_FCLK cycles |
| FA21 ⁽⁵⁾ | t _{acc2-pgmode(DAT)} | Page mode first data maximum access time | | H ⁽²⁾ | | H ⁽²⁾ | | H ⁽²⁾ | GPMC_FCLK cycles |

- (1) The FA5 parameter illustrates the amount of time required to internally sample input Data. It is expressed in number of GPMC functional clock cycles. From start of read cycle and after FA5 functional clock cycles, input Data is internally sampled by active functional clock edge. FA5 value must be stored inside the AccessTime register bit field.
- (2) H = AccessTime * (TimeParaGranularity + 1)
- (3) The FA20 parameter illustrates amount of time required to internally sample successive input Page Data. It is expressed in number of GPMC functional clock cycles. After each access to input Page Data, next input Page Data is internally sampled by active functional clock edge after FA20 functional clock cycles. The FA20 value must be stored in the PageBurstAccessTime register bit field.
- (4) P = PageBurstAccessTime * (TimeParaGranularity + 1)
- (5) The FA21 parameter illustrates amount of time required to internally sample first input Page Data. It is expressed in number of GPMC functional clock cycles. From start of read cycle and after FA21 functional clock cycles, First input Page Data is internally sampled by active functional clock edge. FA21 value must be stored inside the AccessTime register bit field.

Table 6-8. GPMC/NOR Flash Interface Switching Characteristics – Asynchronous Mode

| NO. | PARAMETER | | 1.15 V | | 1.0 V | | 0.9 V | | UNIT | |
|-----|-----------------------------|---|--------|------------------------|------------------------|------------------------|------------------------|------------------------|------------------------|----|
| | | | MIN | MAX | MIN | MAX | MIN | MAX | | |
| | t _{R(DO)} | Rise time, output data | | 2.0 | | 2.0 | | 2.0 | ns | |
| | t _{F(DO)} | Fall time, output data | | 2.0 | | 2.0 | | 2.0 | ns | |
| FA0 | t _{W(nBEV)} | Pulse duration, gpmc_nbe0_cl e, gpmc_nbe1 valid time | Read | N ⁽¹²⁾ | | N ⁽¹²⁾ | | N ⁽¹²⁾ | ns | |
| | | | Write | N ⁽¹²⁾ | | N ⁽¹²⁾ | | N ⁽¹²⁾ | ns | |
| FA1 | t _{W(nCSV)} | Pulse duration, gpmc_ncsx ⁽¹³⁾ v low | Read | A ⁽¹⁾ | | A ⁽¹⁾ | | A ⁽¹⁾ | ns | |
| | | | Write | A ⁽¹⁾ | | A ⁽¹⁾ | | A ⁽¹⁾ | ns | |
| FA3 | t _{d(nCSV-nADVIV)} | Delay time, gpmc_ncsx ⁽¹³⁾ valid to gpmc_nadv_al e invalid | Read | B ⁽²⁾ – 0.2 | B ⁽²⁾ + 2.0 | B ⁽²⁾ – 0.2 | B ⁽²⁾ + 2.6 | B ⁽²⁾ – 0.2 | B ⁽²⁾ + 3.7 | ns |
| | | | Write | B ⁽²⁾ – 0.2 | B ⁽²⁾ + 2.0 | B ⁽²⁾ – 0.2 | B ⁽²⁾ + 2.6 | B ⁽²⁾ – 0.2 | B ⁽²⁾ + 3.7 | ns |
| FA4 | t _{d(nCSV-nOEIV)} | Delay time, gpmc_ncsx ⁽¹³⁾ valid to gpmc_noe invalid (Single read) | | C ⁽³⁾ – 0.2 | C ⁽³⁾ + 2.0 | C ⁽³⁾ – 0.2 | C ⁽³⁾ + 2.6 | C ⁽³⁾ – 0.2 | C ⁽³⁾ + 3.7 | ns |

Table 6-8. GPMC/NOR Flash Interface Switching Characteristics – Asynchronous Mode (continued)

| NO. | PARAMETER | | 1.15 V | | 1.0 V | | 0.9 V | | UNIT |
|------|---------------------|---|-------------------------|-------------------------|-------------------------|-------------------------|-------------------------|-------------------------|------|
| | | | MIN | MAX | MIN | MAX | MIN | MAX | |
| FA9 | $t_{d(AV-nCSV)}$ | Delay time, address bus valid to gpmc_ncsx ⁽¹³⁾ valid | J ⁽⁹⁾ – 0.2 | J ⁽⁹⁾ + 2.0 | J ⁽⁹⁾ – 0.2 | J ⁽⁹⁾ + 2.6 | J ⁽⁹⁾ – 0.2 | J ⁽⁹⁾ + 3.7 | ns |
| FA10 | $t_{d(nBEV-nCSV)}$ | Delay time, gpmc_nbe0_cle, gpmc_nbe1 valid to gpmc_ncsx ⁽¹³⁾ valid | J ⁽⁹⁾ – 0.2 | J ⁽⁹⁾ + 2.0 | J ⁽⁹⁾ – 0.2 | J ⁽⁹⁾ + 2.6 | J ⁽⁹⁾ – 0.2 | J ⁽⁹⁾ + 3.7 | ns |
| FA12 | $t_{d(nCSV-nADV)}$ | Delay time, gpmc_ncsx ⁽¹³⁾ valid to gpmc_nadv_ale valid | K ⁽¹⁰⁾ – 0.2 | K ⁽¹⁰⁾ + 2.0 | K ⁽¹⁰⁾ – 0.2 | K ⁽¹⁰⁾ + 2.6 | K ⁽¹⁰⁾ – 0.2 | K ⁽¹⁰⁾ + 3.7 | ns |
| FA13 | $t_{d(nCSV-nOEV)}$ | Delay time, gpmc_ncsx ⁽¹³⁾ valid to gpmc_noe valid | L ⁽¹¹⁾ – 0.2 | L ⁽¹¹⁾ + 2.0 | L ⁽¹¹⁾ – 0.2 | L ⁽¹¹⁾ + 2.6 | L ⁽¹¹⁾ – 0.2 | L ⁽¹¹⁾ + 3.7 | ns |
| FA14 | $t_{d(nCSV-IODIR)}$ | Delay time, gpmc_ncsx ⁽¹³⁾ valid to gpmc_io_dir high | L ⁽¹¹⁾ – 0.2 | L ⁽¹¹⁾ + 2.0 | L ⁽¹¹⁾ – 0.2 | L ⁽¹¹⁾ + 2.6 | L ⁽¹¹⁾ – 0.2 | L ⁽¹¹⁾ + 3.7 | ns |
| FA15 | $t_{d(nCSV-IODIR)}$ | Delay time, gpmc_ncsx ⁽¹³⁾ valid to gpmc_io_dir low | M ⁽¹⁴⁾ – 0.2 | M ⁽¹⁴⁾ + 2.0 | M ⁽¹⁴⁾ – 0.2 | M ⁽¹⁴⁾ + 2.6 | M ⁽¹⁴⁾ – 0.2 | M ⁽¹⁴⁾ + 3.7 | ns |
| FA16 | $t_{w(AIV)}$ | Address invalid duration between 2 successive R/W accesses | G ⁽⁷⁾ | | G ⁽⁷⁾ | | G ⁽⁷⁾ | | ns |
| FA18 | $t_{d(nCSV-nOEIV)}$ | Delay time, gpmc_ncsx ⁽¹³⁾ valid to gpmc_noe invalid (Burst read) | I ⁽⁸⁾ – 0.2 | I ⁽⁸⁾ + 2.0 | I ⁽⁸⁾ – 0.2 | I ⁽⁸⁾ + 2.6 | I ⁽⁸⁾ – 0.2 | I ⁽⁸⁾ + 3.7 | ns |
| FA20 | $t_{w(AV)}$ | Pulse duration, address valid – 2nd, 3rd, and 4th accesses | D ⁽⁴⁾ | | D ⁽⁴⁾ | | D ⁽⁴⁾ | | ns |
| FA25 | $t_{d(nCSV-nWEV)}$ | Delay time, gpmc_ncsx ⁽¹³⁾ valid to gpmc_nwe valid | E ⁽⁵⁾ – 0.2 | E ⁽⁵⁾ + 2.0 | E ⁽⁵⁾ – 0.2 | E ⁽⁵⁾ + 2.6 | E ⁽⁵⁾ – 0.2 | E ⁽⁵⁾ + 3.7 | ns |
| FA27 | $t_{d(nCSV-nWEIV)}$ | Delay time, gpmc_ncsx ⁽¹³⁾ valid to gpmc_nwe invalid | F ⁽⁶⁾ – 0.2 | F ⁽⁶⁾ + 2.0 | F ⁽⁶⁾ – 0.2 | F ⁽⁶⁾ + 2.6 | F ⁽⁶⁾ – 0.2 | F ⁽⁶⁾ + 3.7 | ns |
| FA28 | $t_{d(nWEV-DV)}$ | Delay time, gpmc_new valid to data bus valid | | 2.0 | | 2.6 | | 3.7 | ns |
| FA29 | $t_{d(DV-nCSV)}$ | Delay time, data bus valid to gpmc_ncsx ⁽¹³⁾ valid | J ⁽⁹⁾ – 0.2 | J ⁽⁹⁾ + 2.0 | J ⁽⁹⁾ – 0.2 | J ⁽⁹⁾ + 2.6 | J ⁽⁹⁾ – 0.2 | J ⁽⁹⁾ + 3.7 | ns |
| FA37 | $t_{d(nOEV-AIV)}$ | Delay time, gpmc_noe valid to gpmc_a[16:1]_d[15:0] address phase end | | 2.0 | | 2.6 | | 3.7 | ns |

(1) **For single read:** A = (CSRdOffTime – CSOnTime) * (TimeParaGranularity + 1) * GPMC_FCLK

For single write: A = (CSWrOffTime – CSOnTime) * (TimeParaGranularity + 1) * GPMC_FCLK

For burst read: A = (CSRdOffTime – CSOnTime + (n – 1) * PageBurstAccessTime) * (TimeParaGranularity + 1) * GPMC_FCLK

For burst write: A = (CSWrOffTime – CSOnTime + (n – 1) * PageBurstAccessTime) * (TimeParaGranularity + 1) * GPMC_FCLK with n being the page burst access number

(2) **For reading:** B = ((ADVRdOffTime – CSOnTime) * (TimeParaGranularity + 1) + 0.5 * (ADVExtraDelay – CSEExtraDelay)) * GPMC_FCLK

For writing: B = ((ADVWrOffTime – CSOnTime) * (TimeParaGranularity + 1) + 0.5 * (ADVExtraDelay – CSEExtraDelay)) * GPMC_FCLK

(3) C = ((OEOffTime – CSOnTime) * (TimeParaGranularity + 1) + 0.5 * (OEEExtraDelay – CSEExtraDelay)) * GPMC_FCLK

(4) D = PageBurstAccessTime * (TimeParaGranularity + 1) * GPMC_FCLK

(5) E = ((WEOnTime – CSOnTime) * (TimeParaGranularity + 1) + 0.5 * (WEEExtraDelay – CSEExtraDelay)) * GPMC_FCLK

(6) F = ((WEOffTime – CSOnTime) * (TimeParaGranularity + 1) + 0.5 * (WEEExtraDelay – CSEExtraDelay)) * GPMC_FCLK

(7) G = Cycle2CycleDelay * GPMC_FCLK

(8) I = ((OEOffTime + (n – 1) * PageBurstAccessTime – CSOnTime) * (TimeParaGranularity + 1) + 0.5 * (OEEExtraDelay – CSEExtraDelay)) * GPMC_FCLK

- (9) $J = (CSONTime * (TimeParaGranularity + 1) + 0.5 * CSEExtraDelay) * GPMC_FCLK$
- (10) $K = ((ADVOnTime - CSONTime) * (TimeParaGranularity + 1) + 0.5 * (ADVExtraDelay - CSEExtraDelay)) * GPMC_FCLK$
- (11) $L = ((OEOnTime - CSONTime) * (TimeParaGranularity + 1) + 0.5 * (OEEExtraDelay - CSEExtraDelay)) * GPMC_FCLK$
- (12) **For single read:** $N = RdCycleTime * (TimeParaGranularity + 1) * GPMC_FCLK$
For single write: $N = WrCycleTime * (TimeParaGranularity + 1) * GPMC_FCLK$
For burst read: $N = (RdCycleTime + (n - 1) * PageBurstAccessTime) * (TimeParaGranularity + 1) * GPMC_FCLK$
For burst write: $N = (WrCycleTime + (n - 1) * PageBurstAccessTime) * (TimeParaGranularity + 1) * GPMC_FCLK$
- (13) In $gpmc_ncsx$, x is equal to 0, 1, 2, 3, 4, 5, 6, or 7.
- (14) $M = ((RdCycleTime - CSONTime) * (TimeParaGranularity + 1) - 0.5 * CSEExtraDelay) * GPMC_FCLK$
 Above M parameter expression is given as one example of GPMC programming. IO DIR signal will go from IN to OUT after both $RdCycleTime$ and $BusTurnAround$ completion. Behavior of IO direction signal does depend on kind of successive Read/Write accesses performed to Memory and multiplexed or non-multiplexed memory addressing scheme, bus keeping feature enabled or not. IO DIR behavior is automatically handled by GPMC controller. For a full description of the $gpmc_io_dir$ feature, see the *OMAP35x Technical Reference Manual (TRM)* [literature number [SPRU98](#)].

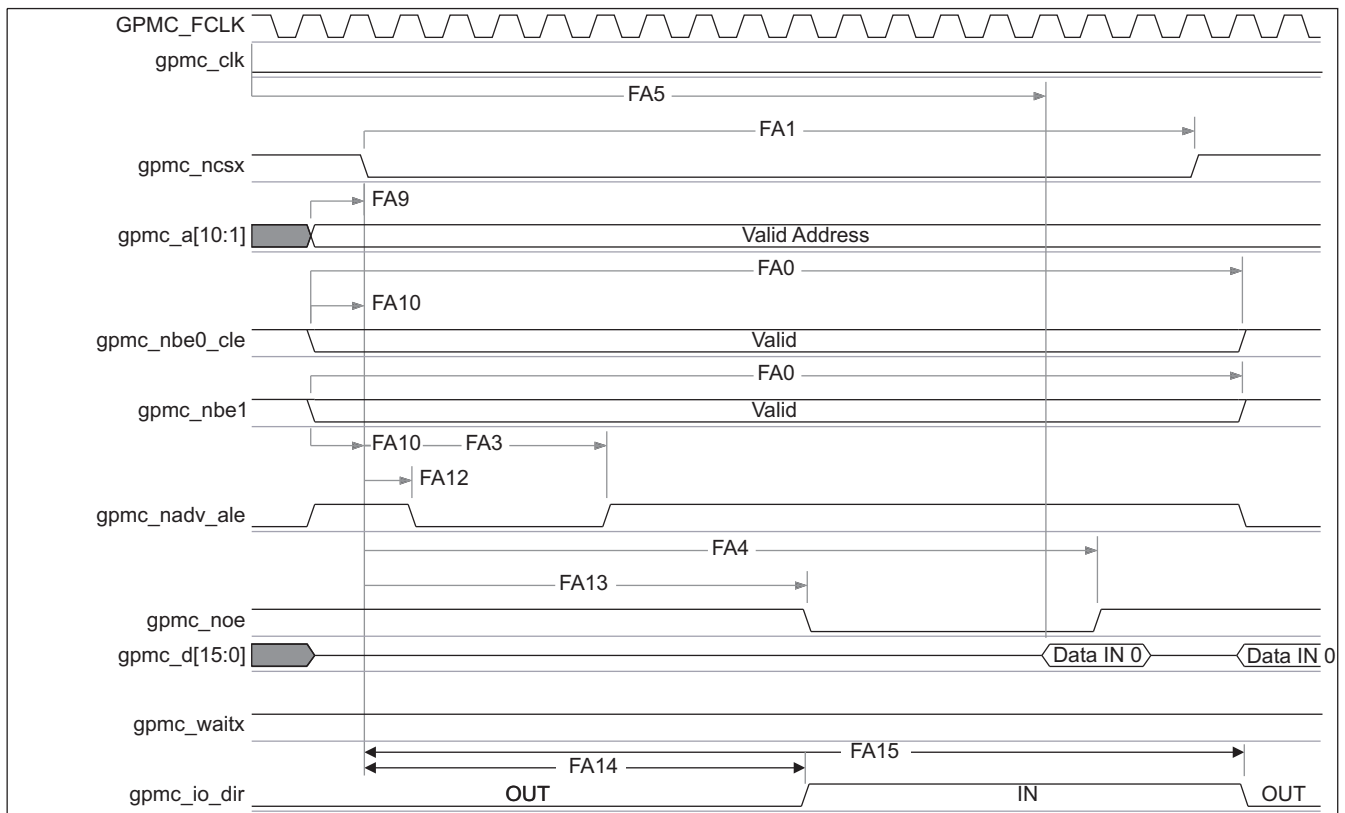

030-026

Figure 6-7. GPMC/NOR Flash – Asynchronous Read – Single Word Timing⁽¹⁾⁽²⁾⁽³⁾

- (1) In $gpmc_ncsx$, x is equal to 0, 1, 2, 3, 4, 5, 6, or 7. In $gpmc_waitx$, x is equal to 0, 1, 2, or 3.
- (2) FA5 parameter illustrates amount of time required to internally sample input data. It is expressed in number of GPMC functional clock cycles. From start of read cycle and after FA5 functional clock cycles, input data is internally sampled by active functional clock edge. FA5 value must be stored inside AccessTime register bit field.
- (3) GPMC_FCLK is an internal clock (GPMC functional clock) not provided externally.

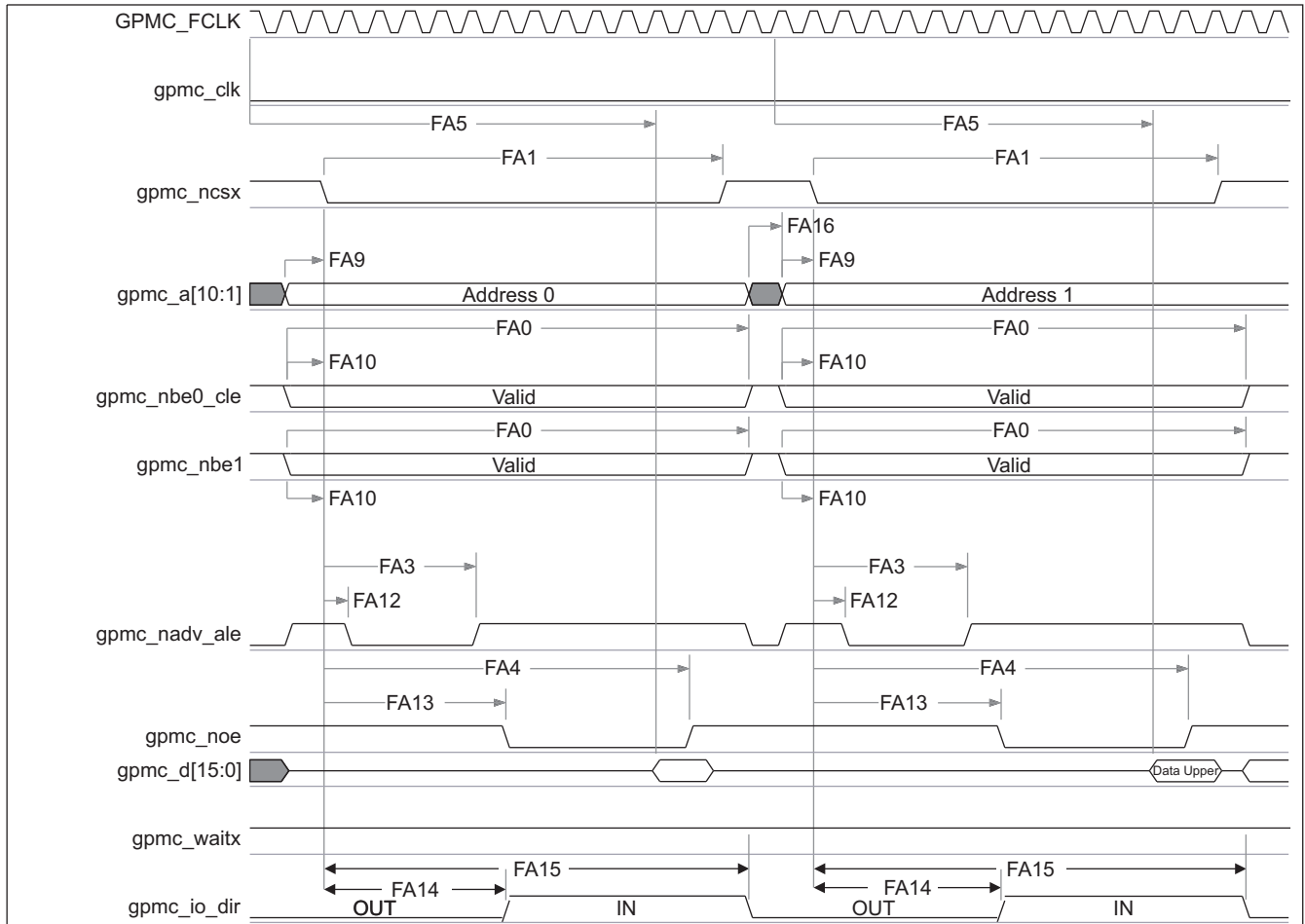

030-027

Figure 6-8. GPMC/NOR Flash – Asynchronous Read – 32-bit Timing⁽¹⁾⁽²⁾⁽³⁾

- (1) In gpmc_ncsx, x is equal to 0, 1, 2, 3, 4, 5, 6, or 7. In gpmc_waitx, x is equal to 0, 1, 2, or 3.
- (2) FA5 parameter illustrates amount of time required to internally sample input data. It is expressed in number of GPMC functional clock cycles. From start of read cycle and after FA5 functional clock cycles, input data is internally sampled by active functional clock edge. FA5 value must be stored inside AccessTime register bit field.
- (3) GPMC_FCLK is an internal clock (GPMC functional clock) not provided externally.

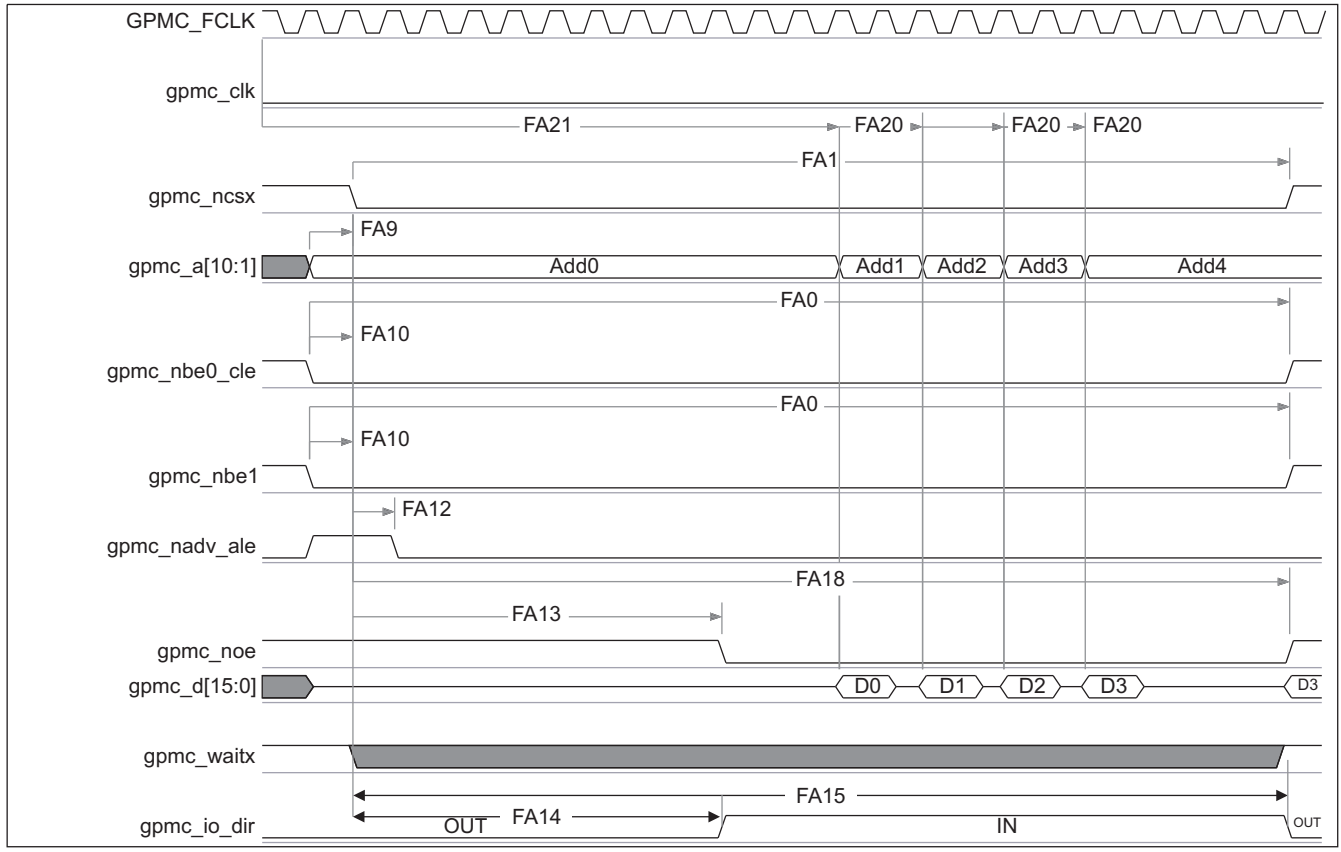

030-028

Figure 6-9. GPMC/NOR Flash – Asynchronous Read – Page Mode 4x16-bit Timing⁽¹⁾⁽²⁾⁽³⁾⁽⁴⁾

- (1) In gpmc_ncsx, x is equal to 0, 1, 2, 3, 4, 5, 6, or 7. In gpmc_waitx, x is equal to 0, 1, 2, or 3.
- (2) FA21 parameter illustrates amount of time required to internally sample first input page data. It is expressed in number of GPMC functional clock cycles. From start of read cycle and after FA21 functional clock cycles, first input page data is internally sampled by active functional clock edge. FA21 value must be stored inside AccessTime register bit field.
- (3) FA20 parameter illustrates amount of time required to internally sample successive input page data. It is expressed in number of GPMC functional clock cycles. After each access to input page data, next input page data is internally sampled by active functional clock edge after FA20 functional clock cycles. FA20 is also the duration of address phases for successive input page data (excluding first input page data). FA20 value must be stored in PageBurstAccessTime register bit field.
- (4) GPMC_FCLK is an internal clock (GPMC functional clock) not provided externally.

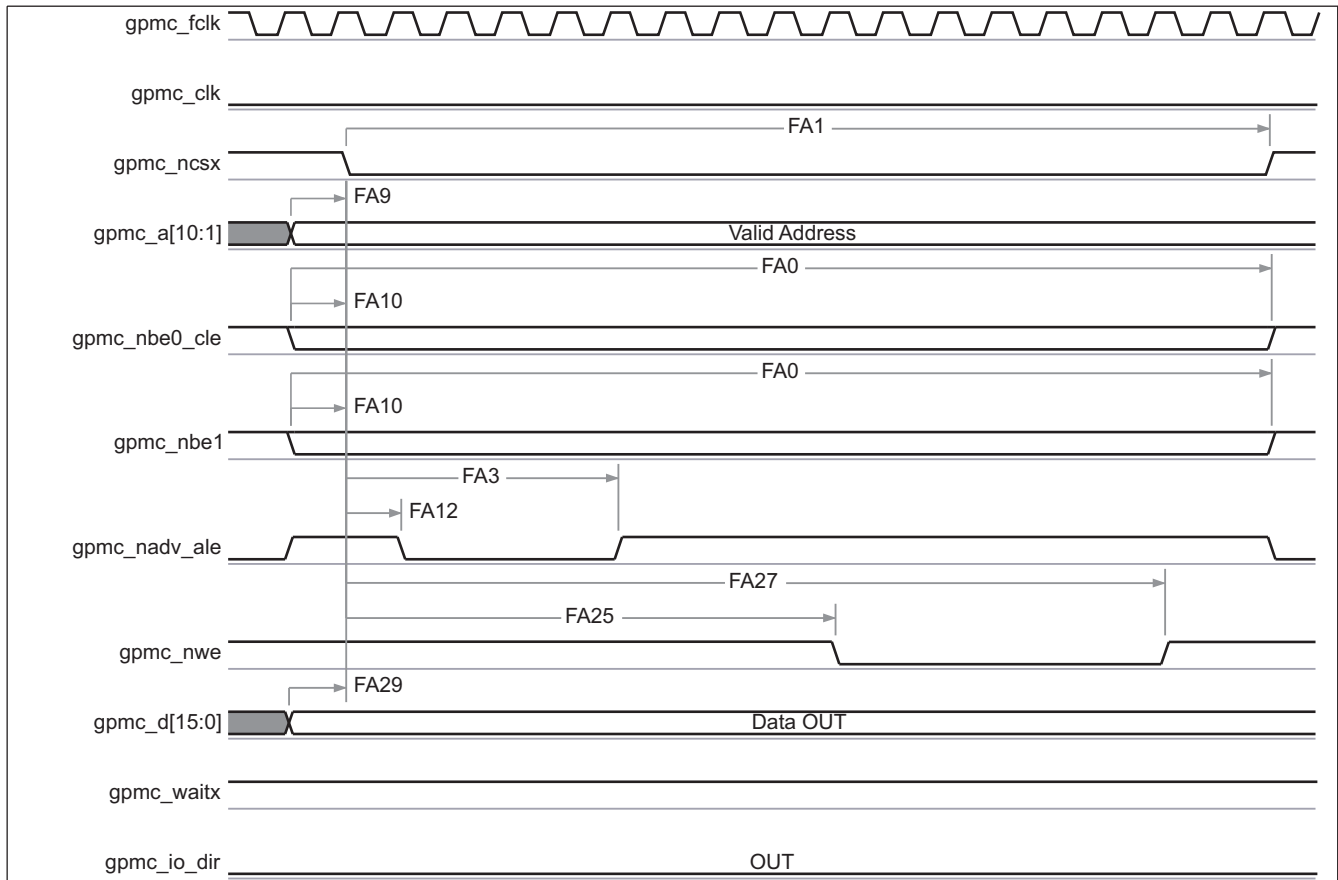

In gpmc_ncsx, x is equal to 0, 1, 2, 3, 4, 5, 6, or 7. In gpmc_waitx, x is equal to 0, 1, 2, or 3.

Figure 6-10. GPMC/NOR Flash – Asynchronous Write – Single Word Timing

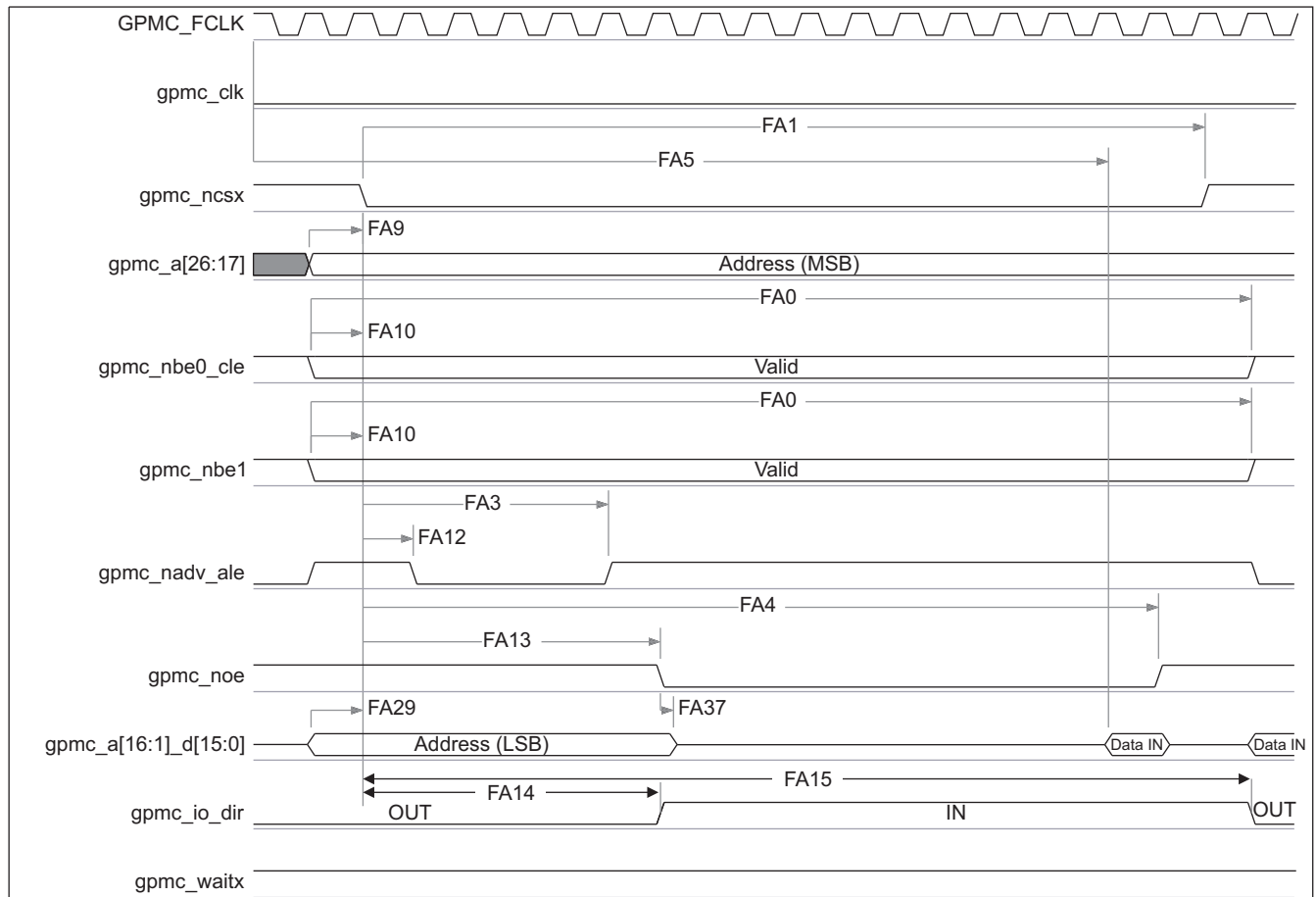

030-030

Figure 6-11. GPMC/Multiplexed NOR Flash – Asynchronous Read – Single Word Timing⁽¹⁾⁽²⁾⁽³⁾

- (1) In gpmc_ncsx, x is equal to 0, 1, 2, 3, 4, 5, 6, or 7. In gpmc_waitx, x is equal to 0, 1, 2, or 3.
- (2) FA5 parameter illustrates amount of time required to internally sample input data. It is expressed in number of GPMC functional clock cycles. From start of read cycle and after FA5 functional clock cycles, input data is internally sampled by active functional clock edge. FA5 value must be stored inside AccessTime register bit field.
- (3) GPMC_FCLK is an internal clock (GPMC functional clock) not provided externally.

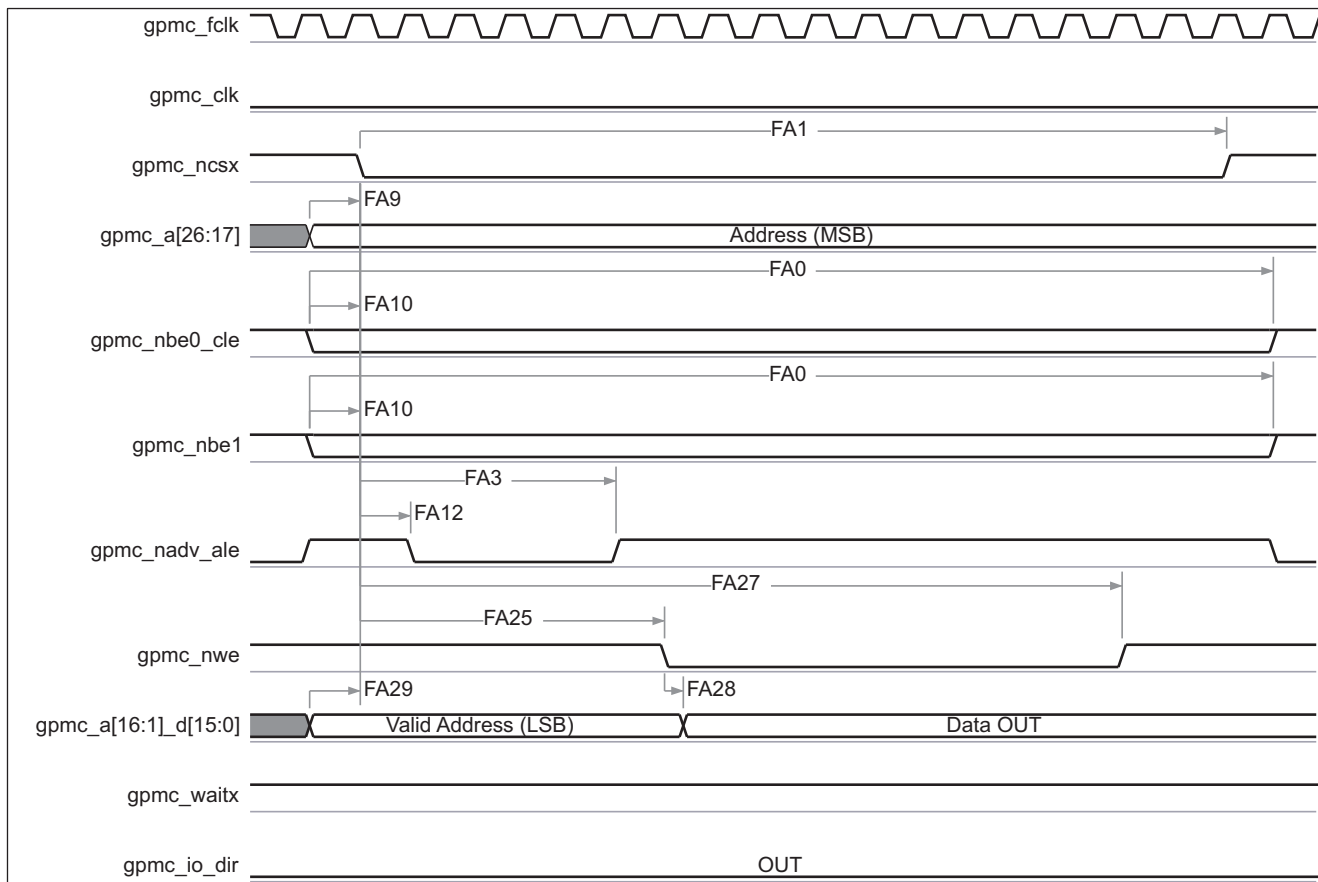

030-031

In gpmc_ncsx, x is equal to 0, 1, 2, 3, 4, 5, 6, or 7. In gpmc_waitx, x is equal to 0, 1, 2, or 3.

Figure 6-12. GPMC/Multiplexed NOR Flash – Asynchronous Write – Single Word Timing

6.4.1.3 GPMC/NAND Flash Interface Timing

Table 6-10 through Table 6-12 assume testing over the recommended operating conditions (see Figure 6-13 through Figure 6-16) and electrical characteristic conditions.

Table 6-9. GPMC/NAND Flash Asynchronous Mode Timing Conditions

| TIMING CONDITION PARAMETER | | VALUE | UNIT |
|----------------------------|-------------------------|-------|------|
| Input Conditions | | | |
| t_R | Input signal rise time | 1.8 | ns |
| t_F | Input signal fall time | 1.8 | ns |
| Output Conditions | | | |
| C_{LOAD} | Output load capacitance | 15.94 | pF |

Table 6-10. GPMC/NAND Flash Interface Asynchronous Timing – Internal Parameters⁽¹⁾⁽²⁾

| NO. | PARAMETER | 1.15 V | | 1.0 V | | 0.9 V | | UNIT |
|-------|---|--------|-----|-------|-----|-------|------|------|
| | | MIN | MAX | MIN | MAX | MIN | MAX | |
| GNFI1 | Maximum output data generation delay from internal functional clock | | 6.5 | | 9.1 | | 13.7 | ns |
| GNFI2 | Maximum input data capture delay by internal functional clock | | 4 | | 5.6 | | 8.1 | ns |

(1) Internal parameters table must be used to calculate data access time stored in the corresponding CS register bit field.

(2) Internal parameters are referred to the GPMC functional internal clock which is not provided externally.

Table 6-10. GPMC/NAND Flash Interface Asynchronous Timing – Internal Parameters (continued)

| NO. | PARAMETER | 1.15 V | | 1.0 V | | 0.9 V | | UNIT |
|-------|--|--------|-----|-------|-----|-------|------|------|
| | | MIN | MAX | MIN | MAX | MIN | MAX | |
| GNF13 | Maximum device select generation delay from internal functional clock | | 6.5 | | 9.1 | | 13.7 | ns |
| GNF14 | Maximum address latch enable generation delay from internal functional clock | | 6.5 | | 9.1 | | 13.7 | ns |
| GNF15 | Maximum command latch enable generation delay from internal functional clock | | 6.5 | | 9.1 | | 13.7 | ns |
| GNF16 | Maximum output enable generation delay from internal functional clock | | 6.5 | | 9.1 | | 13.7 | ns |
| GNF17 | Maximum write enable generation delay from internal functional clock | | 6.5 | | 9.1 | | 13.7 | ns |
| GNF18 | Maximum functional clock skew | | 100 | | 170 | | 200 | ps |

Table 6-11. GPMC/NAND Flash Interface Timing Requirements

| NO. | PARAMETER | | 1.15 V | | 1.0 V | | 0.9 V | | UNIT |
|----------------------|-----------------------|--------------------------|--------|------------------|-------|------------------|-------|------------------|------------------|
| | | | MIN | MAX | MIN | MAX | MIN | MAX | |
| GNF12 ⁽¹⁾ | t _{acc(DAT)} | Data maximum access time | | J ⁽²⁾ | | J ⁽²⁾ | | J ⁽²⁾ | GPMC_FCLK cycles |

(1) The GNF12 parameter illustrates the amount of time required to internally sample input data. It is expressed in number of GPMC functional clock cycles. From start of the read cycle and after GNF12 functional clock cycles, input data is internally sampled by the active functional clock edge. The GNF12 value must be stored inside AccessTime register bit field.

(2) J = AccessTime * (TimeParaGranularity + 1)

Table 6-12. GPMC/NAND Flash Interface Switching Characteristics

| NO. | PARAMETER | | 1.15 V | | 1.0 V | | 0.9 V | | UNIT |
|------|-----------------------------|---|------------------------|------------------------|------------------------|------------------------|------------------------|------------------------|------|
| | | | MIN | MAX | MIN | MAX | MIN | MAX | |
| | t _{R(DO)} | Rise time, output data | | 2.0 | | 2.0 | | 2.0 | ns |
| | t _{F(DO)} | Fall time, output data | | 2.0 | | 2.0 | | 2.0 | ns |
| GNF0 | t _{w(nWEV)} | Pulse duration, gpmc_nwe valid time | A ⁽¹⁾ | | A ⁽¹⁾ | | A ⁽¹⁾ | | ns |
| GNF1 | t _{d(nCSV-nWEV)} | Delay time, gpmc_ncsx ⁽¹³⁾ valid to gpmc_nwe valid | B ⁽²⁾ – 0.2 | B ⁽²⁾ + 2.0 | B ⁽²⁾ – 0.2 | B ⁽²⁾ + 2.6 | B ⁽²⁾ – 0.2 | B ⁽²⁾ + 3.7 | ns |
| GNF2 | t _{w(CLEH-nWEV)} | Delay time, gpmc_nbe0_cle high to gpmc_nwe valid | C ⁽³⁾ – 0.2 | C ⁽³⁾ + 2.0 | C ⁽³⁾ – 0.2 | C ⁽³⁾ + 2.6 | C ⁽³⁾ – 0.2 | C ⁽³⁾ + 3.7 | ns |
| GNF3 | t _{w(nWEV-DV)} | Delay time, gpmc_d[15:0] valid to gpmc_nwe valid | D ⁽⁴⁾ – 0.2 | D ⁽⁴⁾ + 2.0 | D ⁽⁴⁾ – 0.2 | D ⁽⁴⁾ + 2.6 | D ⁽⁴⁾ – 0.2 | D ⁽⁴⁾ + 3.7 | ns |
| GNF4 | t _{w(nWEIV-DIV)} | Delay time, gpmc_nwe invalid to gpmc_d[15:0] invalid | E ⁽⁵⁾ – 0.2 | E ⁽⁵⁾ + 2.0 | E ⁽⁵⁾ – 0.2 | E ⁽⁵⁾ + 2.6 | E ⁽⁵⁾ – 0.2 | E ⁽⁵⁾ + 3.7 | ns |
| GNF5 | t _{w(nWEIV-CLEIV)} | Delay time, gpmc_nwe invalid to gpmc_nbe0_cle invalid | F ⁽⁶⁾ – 0.2 | F ⁽⁶⁾ + 2.0 | F ⁽⁶⁾ – 0.2 | F ⁽⁶⁾ + 2.6 | F ⁽⁶⁾ – 0.2 | F ⁽⁶⁾ + 3.7 | ns |

Table 6-12. GPMC/NAND Flash Interface Switching Characteristics (continued)

| NO. | PARAMETER | | 1.15 V | | 1.0 V | | 0.9 V | | UNIT |
|-------|----------------------|---|------------------|------------------|------------------|------------------|------------------|------------------|------|
| | | | MIN | MAX | MIN | MAX | MIN | MAX | |
| GNF6 | $t_{w(nWEIV-nCSIV)}$ | Delay time, gpmc_nwe invalid to gpmc_ncsx ⁽¹³⁾ invalid | $G^{(7)} - 0.2$ | $G^{(7)} + 2.0$ | $G^{(7)} - 0.2$ | $G^{(7)} + 2.6$ | $G^{(7)} - 0.2$ | $G^{(7)} + 3.7$ | ns |
| GNF7 | $t_{w(ALEH-nWEV)}$ | Delay time, gpmc_nadv_ale High to gpmc_nwe valid | $C^{(3)} - 0.2$ | $C^{(3)} + 2.0$ | $C^{(3)} - 0.2$ | $C^{(3)} + 2.6$ | $C^{(3)} - 0.2$ | $C^{(3)} + 3.7$ | ns |
| GNF8 | $t_{w(nWEIV-ALEIV)}$ | Delay time, gpmc_nwe invalid to gpmc_nadv_ale invalid | $F^{(6)} - 0.2$ | $F^{(6)} + 2.0$ | $F^{(6)} - 0.2$ | $F^{(6)} + 2.6$ | $F^{(6)} - 0.2$ | $F^{(6)} + 3.7$ | ns |
| GNF9 | $t_{c(nWE)}$ | Cycle time, Write cycle time | $H^{(8)}$ | | $H^{(8)}$ | | $H^{(8)}$ | | ns |
| GNF10 | $t_{d(nCSV-nOEV)}$ | Delay time, gpmc_ncsx ⁽¹³⁾ valid to gpmc_noe valid | $I^{(9)} - 0.2$ | $I^{(9)} + 2.0$ | $I^{(9)} - 0.2$ | $I^{(9)} + 2.6$ | $I^{(9)} - 0.2$ | $I^{(9)} + 3.7$ | ns |
| GNF13 | $t_{w(nOEV)}$ | Pulse duration, gpmc_noe valid time | $K^{(10)}$ | | $K^{(10)}$ | | $K^{(10)}$ | | ns |
| GNF14 | $t_{c(nOE)}$ | Cycle time, Read cycle time | $L^{(11)}$ | | $L^{(11)}$ | | $L^{(11)}$ | | ns |
| GNF15 | $t_{w(nOEIV-nCSIV)}$ | Delay time, gpmc_noe invalid to gpmc_ncsx ⁽¹³⁾ invalid | $M^{(12)} - 0.2$ | $M^{(12)} + 2.0$ | $M^{(12)} - 0.2$ | $M^{(12)} + 2.6$ | $M^{(12)} - 0.2$ | $M^{(12)} + 3.7$ | ns |

(1) $A = (WEOffTime - WEOnTime) * (TimeParaGranularity + 1) * GPMC_FCLK$

(2) $B = ((WEOnTime - CSONTime) * (TimeParaGranularity + 1) + 0.5 * (WEEExtraDelay - CSEExtraDelay)) * GPMC_FCLK$

(3) $C = ((WEOnTime - ADVOnTime) * (TimeParaGranularity + 1) + 0.5 * (WEEExtraDelay - ADVEExtraDelay)) * GPMC_FCLK$

(4) $D = (WEOnTime * (TimeParaGranularity + 1) + 0.5 * WEEExtraDelay) * GPMC_FCLK$

(5) $E = ((WrCycleTime - WEOffTime) * (TimeParaGranularity + 1) - 0.5 * WEEExtraDelay) * GPMC_FCLK$

(6) $F = ((ADVWrOffTime - WEOffTime) * (TimeParaGranularity + 1) + 0.5 * (ADVEExtraDelay - WEEExtraDelay)) * GPMC_FCLK$

(7) $G = ((CSWrOffTime - WEOffTime) * (TimeParaGranularity + 1) + 0.5 * (CSEExtraDelay - WEEExtraDelay)) * GPMC_FCLK$

(8) $H = WrCycleTime * (1 + TimeParaGranularity) * GPMC_FCLK$

(9) $I = ((OEOnTime - CSONTime) * (TimeParaGranularity + 1) + 0.5 * (OEEExtraDelay - CSEExtraDelay)) * GPMC_FCLK$

(10) $K = (OEOffTime - OEOnTime) * (1 + TimeParaGranularity) * GPMC_FCLK$

(11) $L = RdCycleTime * (1 + TimeParaGranularity) * GPMC_FCLK$

(12) $M = ((CSRdOffTime - OEOffTime) * (TimeParaGranularity + 1) + 0.5 * (CSEExtraDelay - OEEExtraDelay)) * GPMC_FCLK$

(13) In gpmc_ncsx, x is equal to 0, 1, 2, 3, 4, 5, 6, or 7.

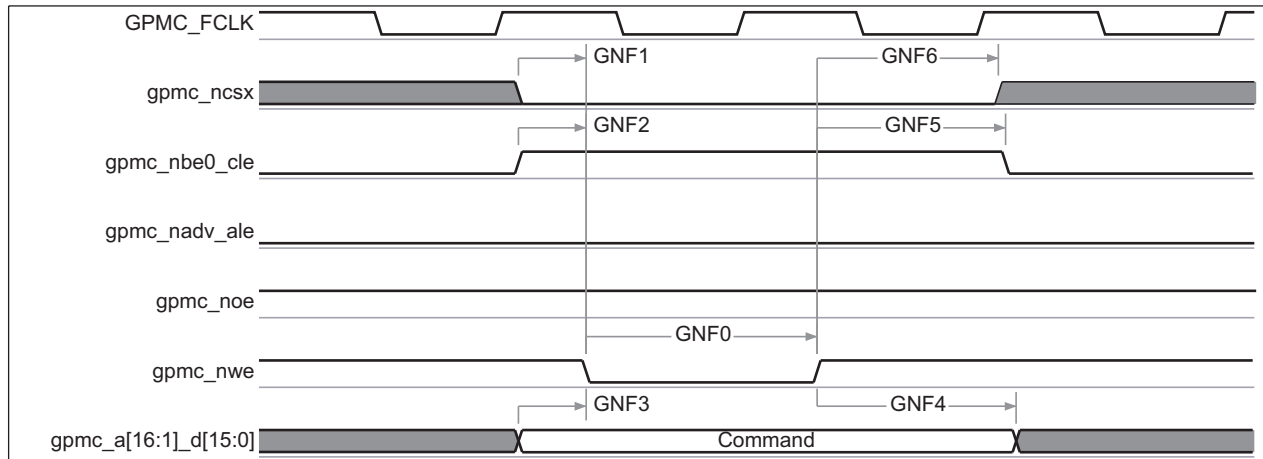

030-032

In gpmc_ncsx, x is equal to 0, 1, 2, 3, 4, 5, 6, or 7.

Figure 6-13. GPMC/NAND Flash – Command Latch Cycle Timing

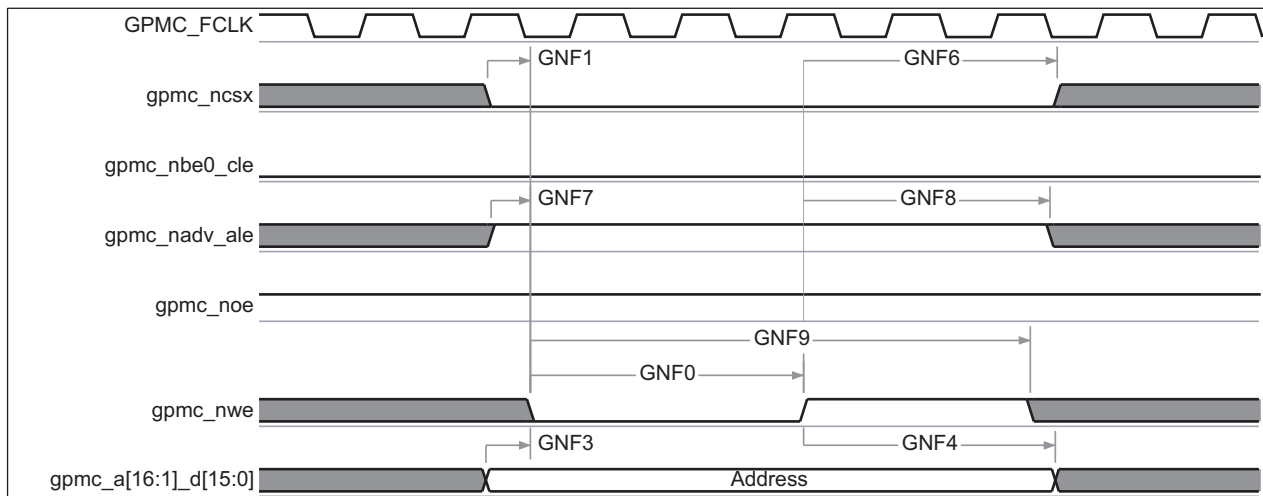

030-033

In gpmc_ncsx, x is equal to 0, 1, 2, 3, 4, 5, 6, or 7.

Figure 6-14. GPMC/NAND Flash – Address Latch Cycle Timing

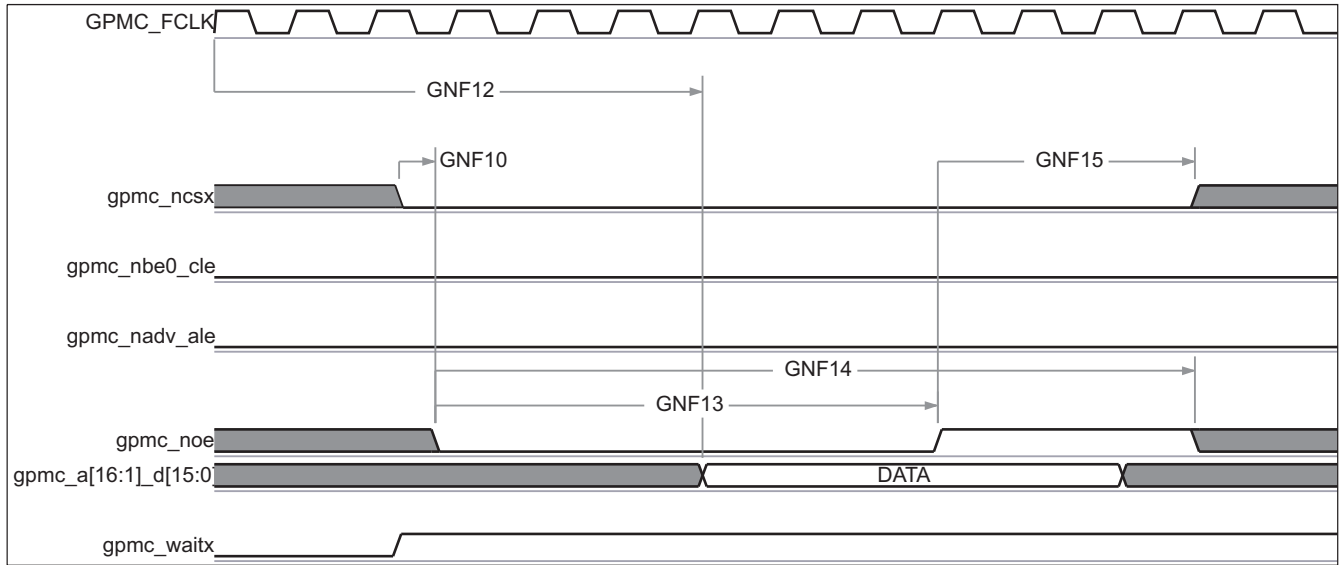

030-034

Figure 6-15. GPMC/NAND Flash – Data Read Cycle Timing⁽¹⁾⁽²⁾⁽³⁾

- (1) The GNF12 parameter illustrates amount of time required to internally sample input data. It is expressed in number of GPMC functional clock cycles. From start of read cycle and after GNF12 functional clock cycles, input data is internally sampled by active functional clock edge. The GNF12 value must be stored inside AccessTime register bit field.
- (2) GPMC_FCLK is an internal clock (GPMC functional clock) not provided externally.
- (3) In gpmc_ncsx, x is equal to 0, 1, 2, 3, 4, 5, 6, or 7. In gpmc_waitx, x is equal to 0, 1, 2, or 3.

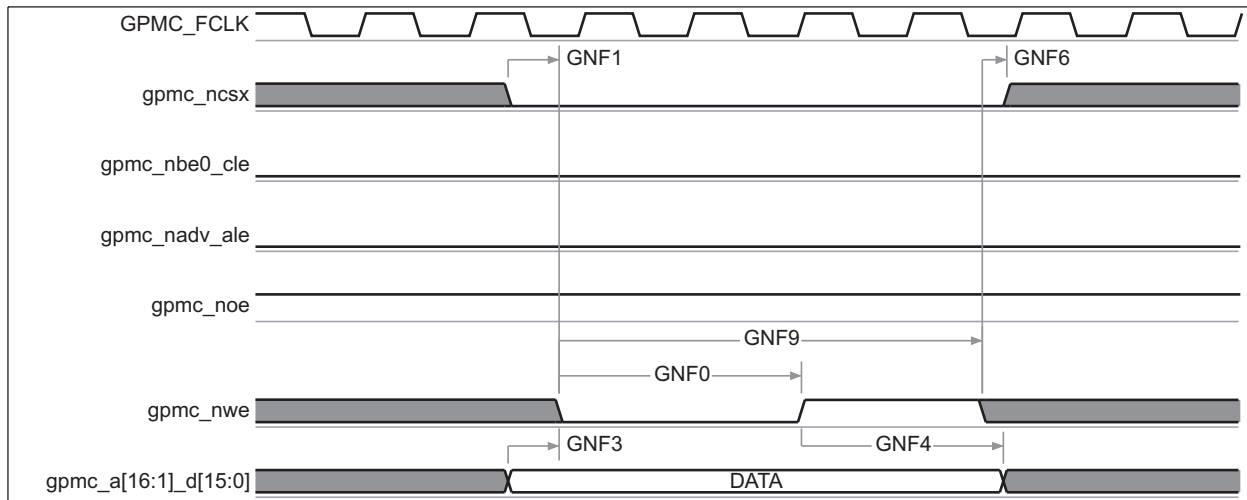

030-035

In gpmc_ncsx, x is equal to 0, 1, 2, 3, 4, 5, 6, or 7. In gpmc_waitx, x is equal to 0 or 1.

Figure 6-16. GPMC/NAND Flash – Data Write Cycle Timing

6.4.2 SDRAM Controller Subsystem (SDRC)

The SDRAM controller subsystem (SDRC) module provides connectivity between the OMAP35x Applications Processor and external DRAM memory components. The SDRC module only supports low-power double-data-rate (LPDDR) SDRAM devices. Memory devices can be interfaced to the SDRC using a stacked-memory approach or through the printed circuit board (PCB). The stacked-memory approach uses the package on package interface pins (available on CBB & CBC package).

6.4.2.1 SDRAM Controller Subsystem Device-Specific Information

The approach to specifying interface timing for the SDRC memory bus is different than on other interfaces such as the general-purpose memory controller (GPMC) and the multi-channel buffered serial ports (McBSPs). For these other interfaces the device timing was specified in terms of data manual specifications and I/O buffer information specification (IBIS) models.

For the SDRC memory bus, the approach is to specify compatible memory devices and provide the printed circuit board (PCB) solution and guidelines directly to the user. Texas Instruments (TI) has performed the simulation and system characterization to ensure all interface timings in this solution are met.

6.4.2.2 LPDDR Interface

The LPDDR interface is balled out on the bottom side of all OMAP35x packages and on the top side of OMAP35x POP packages. The LPDDR interface on the top of the POP package has been designed for compatibility any POP LPDDR device with a matching footprint and compliance with the JEDEC LPDDR-266 specification.

This section provides the timing specification for the bottom-side LPDDR interface as a PCB design and manufacturing specification. The design rules constrain PCB trace length, PCB trace skew, signal integrity, cross-talk, and signal timing. These rules, when followed, result in a reliable LPDDR memory system without the need for a complex timing closure process. For more information regarding guidelines for using this LPDDR specification, see the *Understanding TI's PCB Routing Rule-Based DDR Timing Specification* Application Report (literature number [SPRAAV0](#)).

6.4.2.2.1 LPDDR Interface Schematic

[Figure 6-17](#) and [Figure 6-18](#) show the LPDDR interface schematics for a LPDDR memory system. The 1 x16 LPDDR system schematic is identical to [Figure 6-17](#) except that the high word LPDDR device is deleted.

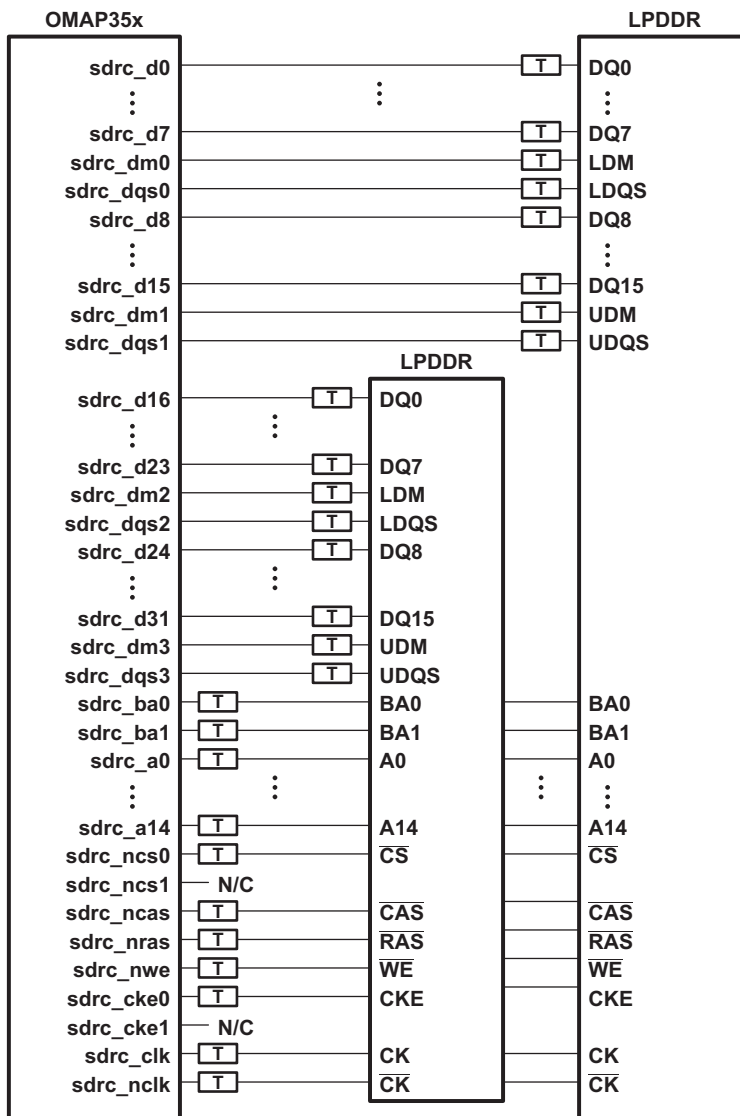

Figure 6-17. OMAP35x LPDDR High Level Schematic (x16 memories)

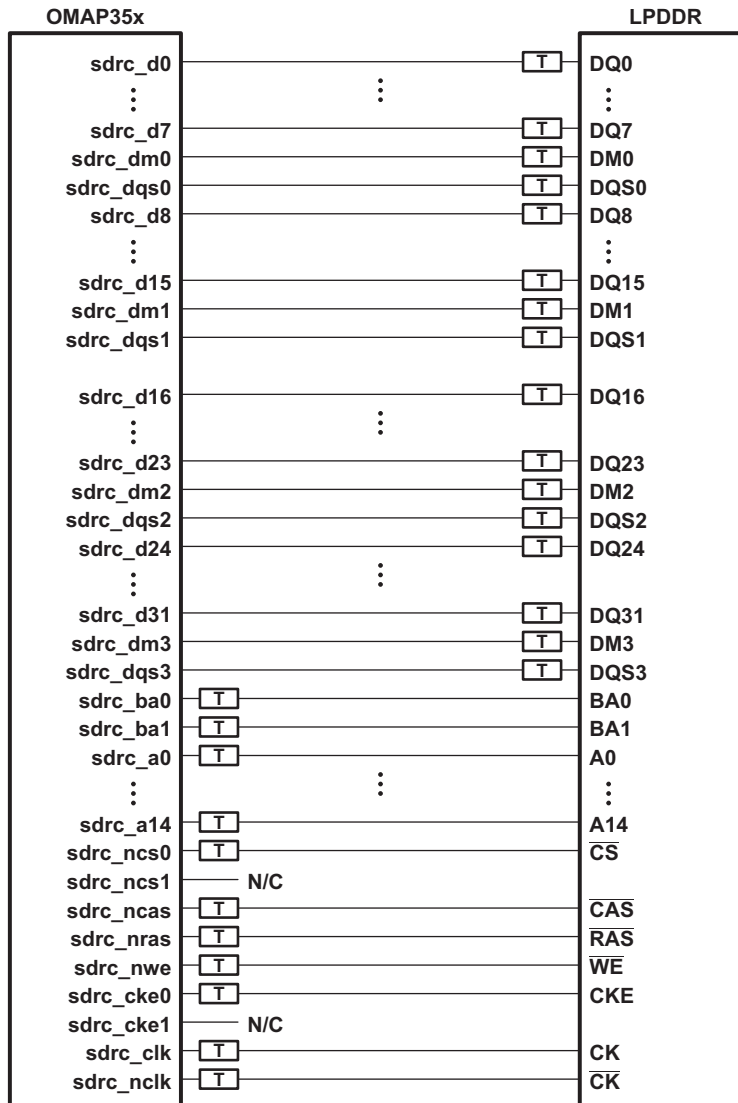

Figure 6-18. OMAP35x LPDDR High Level Schematic (x32 memory)

6.4.2.2.2 Compatible JEDEC LPDDR Devices

Table 6-13 shows the parameters of the JEDEC LPDDR devices that are compatible with this interface. Generally, the LPDDR interface is compatible with x16 and x32 LPDDR266 and LPDDR333 speed grade LPDDR devices.

Table 6-13. Compatible JEDEC LPDDR Devices

| NO. | PARAMETER | MIN | MAX | UNIT | NOTES |
|-----|--------------------------------|-----------|-----|---------|--------------|
| 1 | JEDEC LPDDR Device Speed Grade | LPDDR-266 | | | See Note (1) |
| 2 | JEDEC LPDDR Device Bit Width | 16 | 32 | Bits | |
| 3 | JEDEC LPDDR Device Count | 1 | 2 | Devices | See Note (2) |
| 4 | JEDEC LPDDR Device Ball Count | 60 | 90 | Balls | |

(1) Higher LPDDR speed grades are supported due to inherent JEDEC LPDDR backwards compatibility.

(2) 1 x16 LPDDR device is used for 16 bit LPDDR memory system. 1x32 or 2x16 LPDDR devices are used for a 32-bit LPDDR memory system.

6.4.2.2.3 PCB Stackup

The minimum stackup required for routing the OMAP35x is a six layer stack as shown in [Table 6-14](#). Additional layers may be added to the PCB stack up to accommodate other circuitry or to reduce the size of the PCB footprint.

Table 6-14. OMAP35x Minimum PCB Stack Up

| LAYER | TYPE | DESCRIPTION |
|-------|--------|--------------------------------|
| 1 | Signal | Top Routing Mostly Horizontal |
| 2 | Plane | Ground |
| 3 | Plane | Power |
| 4 | Signal | Internal Routing |
| 5 | Plane | Ground |
| 6 | Signal | Bottom Routing Mostly Vertical |

Table 6-15. PCB Stack Up Specifications

| NO. | PARAMETER | MIN | TYP | MAX | UNIT | NOTES |
|-----|---|-----|-----|-------|------|-------------------------|
| 1 | PCB Routing/Plane Layers | 6 | | | | |
| 2 | Signal Routing Layers | 3 | | | | |
| 3 | Full ground layers under LPDDR routing region | 2 | | | | |
| 4 | Number of ground plane cuts allowed within LPDDR routing region | | | 0 | | |
| 5 | Number of ground reference planes required for each LPDDR routing 1 layer | 1 | | | | |
| 6 | Number of layers between LPDDR routing layer and reference ground 0 plane | | | 0 | | |
| 7 | PCB Routing Feature Size | | 4 | | Mils | |
| 8 | PCB Trace Width w | | 4 | | Mils | |
| 9 | PCB BGA escape via pad size | | 18 | | Mils | |
| 10 | PCB BGA escape via hole size | | 8 | | Mils | |
| 11 | Device BGA Pad Size | | | | | See Note ⁽¹⁾ |
| 12 | LPDDR Device BGA Pad Size | | | | | See Note ⁽²⁾ |
| 13 | Single Ended Impedance, ZO | 50 | | 75 | Ω | |
| 14 | Impedance Control | Z-5 | Z | Z + 5 | Ω | See Note ⁽³⁾ |

(1) Please see the *Flip Chip Ball Grid Array Package Reference Guide* (literature number [SPRU811](#)) for device BGA pad size.

(2) Please see the LPDDR device manufacturer documentation for the LPDDR device BGA pad size.

(3) Z is the nominal singled ended impedance selected for the PCB specified by item 12.

6.4.2.3 Placement

[Figure 6-19](#) shows the required placement for the OMAP35x device as well as the LPDDR devices. The dimensions for [Figure 6-19](#) are defined in [Table 6-16](#). The placement does not restrict the side of the PCB that the devices are mounted on. The ultimate purpose of the placement is to limit the maximum trace lengths and allow for proper routing space. For 1x16 and 1x32 LPDDR memory systems, the second LPDDR device is omitted from the placement.

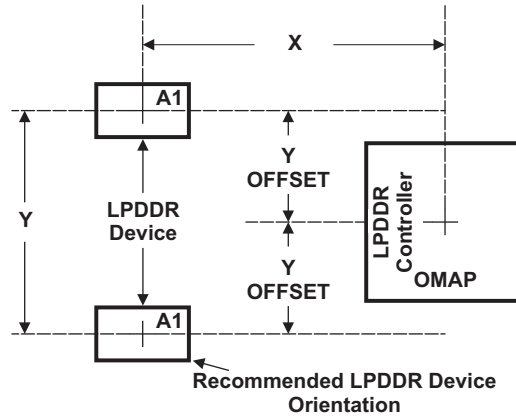

Figure 6-19. OMAP35x and LPDDR Device Placement

Table 6-16. Placement Specifications

| NO. | PARAMETER | MIN | MAX | UNIT | NOTES |
|-----|---|-----|------|------|--|
| 1 | X | | 1440 | Mils | See Notes ⁽¹⁾ , ⁽²⁾ |
| 2 | Y | | 1030 | Mils | See Notes ⁽¹⁾ , ⁽²⁾ |
| 3 | Y Offset | | 525 | Mils | See Notes ⁽¹⁾ , ⁽²⁾ , ⁽³⁾ |
| 4 | LPDDR Keepout Region | | | | See Note ⁽⁴⁾ |
| 5 | Clearance from non-LPDDR signal to LPDDR Keepout Region | 4 | | w | See Note ⁽⁵⁾ |

- (1) See Figure 6-17 for dimension definitions.
- (2) Measurements from center of device to center of LPDDR device.
- (3) For 16 bit memory systems it is recommended that Y Offset be as small as possible.
- (4) LPDDR keepout region to encompass entire LPDDR routing area.
- (5) Non-LPDDR signals allowed within LPDDR keepout region provided they are separated from LPDDR routing layers by a ground plane.

6.4.2.4 LPDDR Keep Out Region

The region of the PCB used for the LPDDR circuitry must be isolated from other signals. The LPDDR keep out region is defined for this purpose and is shown in Figure 6-20. The size of this region varies with the placement and LPDDR routing. Additional clearances required for the keep out region are shown in Table 6-16.

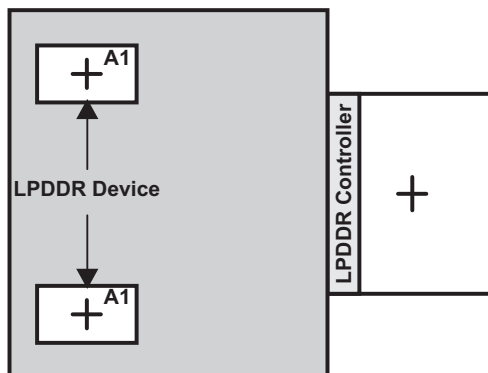

Region should encompass all LPDDR circuitry and varies depending on placement. Non-LPDDR signals should not be routed on the LPDDR signal layers within the LPDDR keep out region. Non-LPDDR signals may be routed in the region provided they are routed on layers separated from LPDDR signal layers by a ground layer. No breaks should be allowed in the reference ground layers in this region. In addition, the 1.8 V power plane should cover the entire keep out region.

Figure 6-20. LPDDR Keepout Region

6.4.2.5 Net Classes

Table 6-17 lists the clock net classes for the LPDDR interface. Table 6-18 lists the signal net classes, and associated clock net classes, for the signals in the LPDDR interface. These net classes are used for the termination and routing rules that follow.

Table 6-17. Clock Net Class Definitions

| CLOCK NET CLASS | OMAP PIN NAMES |
|-----------------|--------------------|
| CK | sdrc_clk/sdrc_nclk |
| DQS0 | sdrc_dqs0 |
| DQS1 | sdrc_dqs1 |
| DQS2 | sdrc_dqs2 |
| DQS3 | sdrc_dqs3 |

Table 6-18. Signal Net Class Definitions

| CLOCK NET CLASS | ASSOCIATED CLOCK NET CLASS | OMAP PIN NAMES |
|-----------------|----------------------------|---|
| ADDR_CTRL | CK | sdrc_ba, sdrc_a, sdrc_ncs0, sdrc_ncas, sdrc_nras, sdrc_nwe, sdrc_cke0 |
| DQ0 | DQS0 | sdrc_d, sdrc_dm0 |
| DQ1 | DQS1 | sdrc_d, sdrc_dm1 |
| DQ2 | DQS2 | sdrc_d, sdrc_dm2 |
| DQ3 | DQS3 | sdrc_d, sdrc_dm3 |

6.4.2.6 LPDDR Signal Termination

No terminations of any kind are required in order to meet signal integrity and overshoot requirements. Serial terminators are permitted, if desired, to reduce EMI risk; however, serial terminations are the only type permitted. Table 6-19 shows the specifications for the series terminators.

Table 6-19. LPDDR Signal Terminations

| NO. | PARAMETER | MIN | TYP | MAX | UNIT | NOTES |
|-----|--------------|-----|-----|-----|----------|-------------------------|
| 1 | CK Net Class | 0 | | 10 | Ω | See Note ⁽¹⁾ |

(1) Only series termination is permitted, parallel or SST specifically disallowed.

Table 6-19. LPDDR Signal Terminations (continued)

| NO. | PARAMETER | MIN | TYP | MAX | UNIT | NOTES |
|-----|--|-----|-----|-----|----------|------------------------------------|
| 2 | ADDR_CTRL Net Class | 0 | 22 | Zo | Ω | See Notes ^{(1), (2), (3)} |
| 3 | Data Byte Net Classes (DQS0-DQS3, DQ0-DQ3) | 0 | 22 | Zo | Ω | See Notes ^{(1), (2), (3)} |

(2) Terminator values larger than typical only recommended to address EMI issues.

(3) Termination value should be uniform across net class.

6.4.2.7 LPDDR CK and ADDR_CTRL Routing

Figure 6-21 shows the topology of the routing for the CK and ADDR_CTRL net classes. The route is a balanced T as it is intended that the length of segments B and C be equal. In addition, the length of A should be maximized.

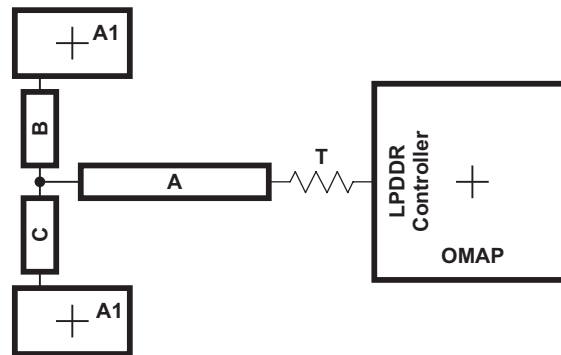

Figure 6-21. CK and ADDR_CTRL Routing and Topology

Table 6-20. CK and ADDR_CTRL Routing Specification

| NO. | PARAMETER | MIN | TYP | MAX | UNIT | NOTES |
|-----|--|----------|-------|----------|------|-------------------------|
| 1 | Center to Center CK-CK spacing | | | 2w | | |
| 2 | CK A to B/A to C Skew Length Mismatch | | | 25 | Mils | See Note ⁽¹⁾ |
| 3 | CK B to C Skew Length Mismatch | | | 25 | Mils | |
| 4 | Center to Center CK to other LPDDR trace spacing | 4w | | | | See Note ⁽²⁾ |
| 5 | CK/ADDR_CTRL nominal trace length | CACLM-50 | CACLM | CACLM+50 | Mils | See Note ⁽³⁾ |
| 6 | ADDR_CTRL to CK Skew Length Mismatch | | | 100 | Mils | |
| 7 | ADDR_CTRL to ADDR_CTRL Skew Length Mismatch | | | 100 | Mils | |
| 8 | Center to Center ADDR_CTRL to other LPDDR trace 4w spacing | 4w | | | | See Note ⁽²⁾ |
| 9 | Center to Center ADDR_CTRL to other ADDR_CTRL 3w trace spacing | 3w | | | | See Note ⁽²⁾ |
| 10 | ADDR_CTRL A to B/A to C Skew Length Mismatch | | | 100 | Mils | See Note ⁽¹⁾ |
| 11 | ADDR_CTRL B to C Skew Length Mismatch | | | 100 | Mils | |

(1) Series terminator, if used, should be located closest to device.

(2) Center to center spacing is allowed to fall to minimum (w) for up to 500 mils of routed length to accommodate BGA escape and routing congestion.

(3) CACLM is the longest Manhattan distance of the CK and ADDR_CTRL net classes.

Figure 6-22 shows the topology and routing for the DQS and DQ net classes; the routes are point to point. Skew matching across bytes is not needed nor recommended.

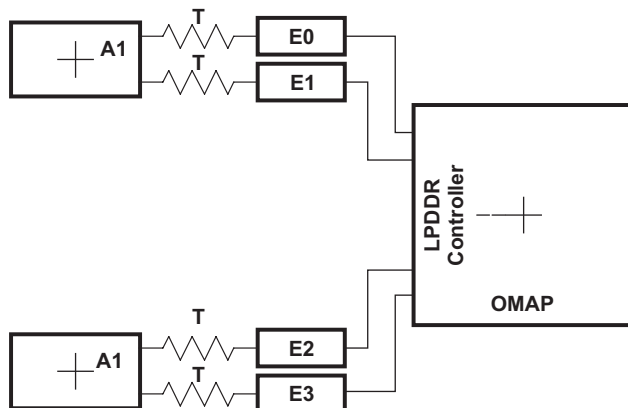

Figure 6-22. DQS and DQ Routing and Topology

Table 6-21. DQS and DQ Routing Specification⁽¹⁾

| NO. | PARAMETER | MIN | TYP | MAX | UNIT | NOTES |
|-----|---|-----------|------|-----------|------|------------------------------|
| 2 | DQS E Skew Length Mismatch | | | 25 | Mils | |
| 3 | Center to Center DQS to other LPDDR trace spacing | 4w | | | | See Note ⁽²⁾ |
| 4 | DQS/DQ nominal trace length | DQLM - 50 | DQLM | DQLM + 50 | Mils | See Note ⁽³⁾ |
| 5 | DQ to DQS Skew Length Mismatch | | | 100 | Mils | |
| 6 | DQ to DQ Skew Length Mismatch | | | 100 | Mils | |
| 7 | Center to Center DQ to other LPDDR trace spacing | 4w | | | | See Note ⁽²⁾ |
| 8 | Center to Center DQ to other DQ trace spacing | 3w | | | | See Note ^{(2), (4)} |
| 9 | DQ E Skew Length Mismatch | | | 100 | Mils | |

- (1) Series terminator, if used, should be located closest to LPDDR.
- (2) Center to center spacing is allowed to fall to minimum (w) for up to 500 mils of routed length to accommodate BGA escape and routing congestion.
- (3) Center to center spacing is allowed to fall to minimum (w) for up to 500 mils of routed length to accommodate BGA escape and routing congestion.
- (4) DQLM is the longest Manhattan distance of the DQS and DQ net classes.

6.5 Video Interfaces

6.5.1 Camera Interface

The camera subsystem provides the system interfaces and the processing capability to connect raw, YUV, or JPEG image sensor modules to the OMAP3530/25 device for video-preview, video-record, and still-image-capture applications. The camera subsystem supports up to two simultaneous pixel flows but only one of them can use the video processing hardware:

- PARALLEL: the parallel interface data must go through the video processing hardware.

6.5.1.1 Parallel Camera Interface Timing

The parallel camera interface is a 12-bit interface which can be used in two modes:

1. SYNC mode: progressive and interlaced image sensor modules for 8-, 10-, 11-, and 12-bit data. The pixel clock can be up to 75 MHz in 12-bit mode. The pixel clock can be up to 130 MHz in 8-bit packed mode.
2. ITU mode provides an ITU-R BT 656 compatible data stream with progressive image sensor modules only in 8- and 10-bit configurations. The pixel clock can be up to 75 MHz.

6.5.1.1.1 SYNC Normal Mode

6.5.1.1.1.1 12-Bit SYNC Normal – Progressive Mode

Table 6-23 and Table 6-24 assume testing over the recommended operating conditions and electrical characteristic conditions (see Figure 6-23).

Table 6-22. ISP Timing Conditions – 12-Bit SYNC Normal – Progressive Mode

| TIMING CONDITION PARAMETER | | VALUE | UNIT |
|----------------------------|-------------------------|-------|------|
| Input Conditions | | | |
| t_R | Input signal rise time | 2.7 | ns |
| t_F | Input signal fall time | 2.7 | ns |
| Output Condition | | | |
| C_{LOAD} | Output load capacitance | 8.6 | pF |

Table 6-23. ISP Timing Requirements – 12-Bit SYNC Normal – Progressive Mode⁽¹⁾

| NO. | PARAMETER | | 1.15 V | | 1.0 V | | UNIT |
|-------|--------------------|---|----------------------|-----|----------------------|------|------|
| | | | MIN | MAX | MIN | MAX | |
| ISP17 | $t_{c(pclk)}$ | Cycle time ⁽²⁾ , cam_pclk period | 13.3 | | 22.2 | | ns |
| ISP18 | $t_{W(pclkH)}$ | Typical pulse duration, cam_pclk high | 0.5*P ⁽³⁾ | | 0.5*P ⁽³⁾ | | ns |
| ISP18 | $t_{W(pclkL)}$ | Typical pulse duration, cam_pclk low | 0.5*P ⁽³⁾ | | 0.5*P ⁽³⁾ | | ns |
| | $t_{dc(pclk)}$ | Duty cycle error, cam_pclk | | 667 | | 1111 | ps |
| | $t_{j(pclk)}$ | Cycle jitter ⁽⁴⁾ , cam_pclk | | 133 | | 200 | ps |
| ISP19 | $t_{su(dV-pclkH)}$ | Setup time, cam_d[11:0] valid before cam_pclk rising edge | 1.82 | | 3.25 | | ns |
| ISP20 | $t_{h(pclkH-dV)}$ | Hold time, cam_d[11:0] valid after cam_pclk rising edge | 1.82 | | 3.25 | | ns |
| ISP21 | $t_{su(dV-vsH)}$ | Setup time, cam_vs valid before cam_pclk rising edge | 1.82 | | 3.25 | | ns |
| ISP22 | $t_{h(pclkH-vsV)}$ | Hold time, cam_vs valid after cam_pclk rising edge | 1.82 | | 3.25 | | ns |
| ISP23 | $t_{su(dV-hsH)}$ | Setup time, cam_hs valid before cam_pclk rising edge | 1.82 | | 3.25 | | ns |

(1) The timing requirements are assured for the cycle jitter and duty cycle error conditions specified.

(2) Related with the input maximum frequency supported by the ISP module.

(3) P = cam_pclk period in ns

(4) Maximum cycle jitter supported by cam_pclk input clock.

Table 6-23. ISP Timing Requirements – 12-Bit SYNC Normal – Progressive Mode (continued)

| NO. | PARAMETER | | 1.15 V | | 1.0 V | | UNIT |
|-------|--------------------|---|--------|-----|-------|-----|------|
| | | | MIN | MAX | MIN | MAX | |
| ISP24 | $t_{h(pclkH-hsV)}$ | Hold time, cam_hs valid after cam_pclk rising edge | 1.82 | | 3.25 | | ns |
| ISP25 | $t_{su(dV-hsH)}$ | Setup time, cam_wen valid before cam_pclk rising edge | 1.82 | | 3.25 | | ns |
| ISP26 | $t_{h(pclkH-hsV)}$ | Hold time, cam_wen valid after cam_pclk rising edge | 1.82 | | 3.25 | | ns |

Table 6-24. ISP Switching Characteristics – 12-Bit SYNC Normal – Progressive Mode

| NO. | PARAMETER | | 1.15 V | | 1.0 V | | UNIT |
|-------|----------------|---|-----------------------|------|-----------------------|------|------|
| | | | MIN | MAX | MIN | MAX | |
| ISP15 | $t_{c(xclk)}$ | Cycle time ⁽¹⁾ , cam_xclk period | 4.6 | | 4.6 | | ns |
| ISP16 | $t_{W(xclkH)}$ | Typical pulse duration, cam_xclk high | 0.5*PO ⁽²⁾ | | 0.5*PO ⁽²⁾ | | ns |
| ISP16 | $t_{W(xclkL)}$ | Typical pulse duration, cam_xclk low | 0.5*PO ⁽²⁾ | | 0.5*PO ⁽²⁾ | | ns |
| | $t_{dc(xclk)}$ | Duty cycle error, cam_xclk | | 231 | | 231 | ps |
| | $t_{j(xclk)}$ | Jitter standard deviation ⁽³⁾ , cam_xclk | | 33 | | 33 | ps |
| | $t_{R(xclk)}$ | Rise time, cam_xclk | | 0.93 | | 0.93 | ns |
| | $t_{F(xclk)}$ | Fall time, cam_xclk | | 0.93 | | 0.93 | ns |

(1) Related with the cam_xclk maximum and minimum frequencies programmable in the ISP module.

Warning: The camera sensor or the camera module must be disabled to change the frequency configuration. For more information, see the *OMAP35x Technical Reference Manual (TRM)* [literature number [SPRUF98](#)]

(2) PO = cam_xclk period in ns

(3) The jitter probability density can be approximated by a Gaussian function.

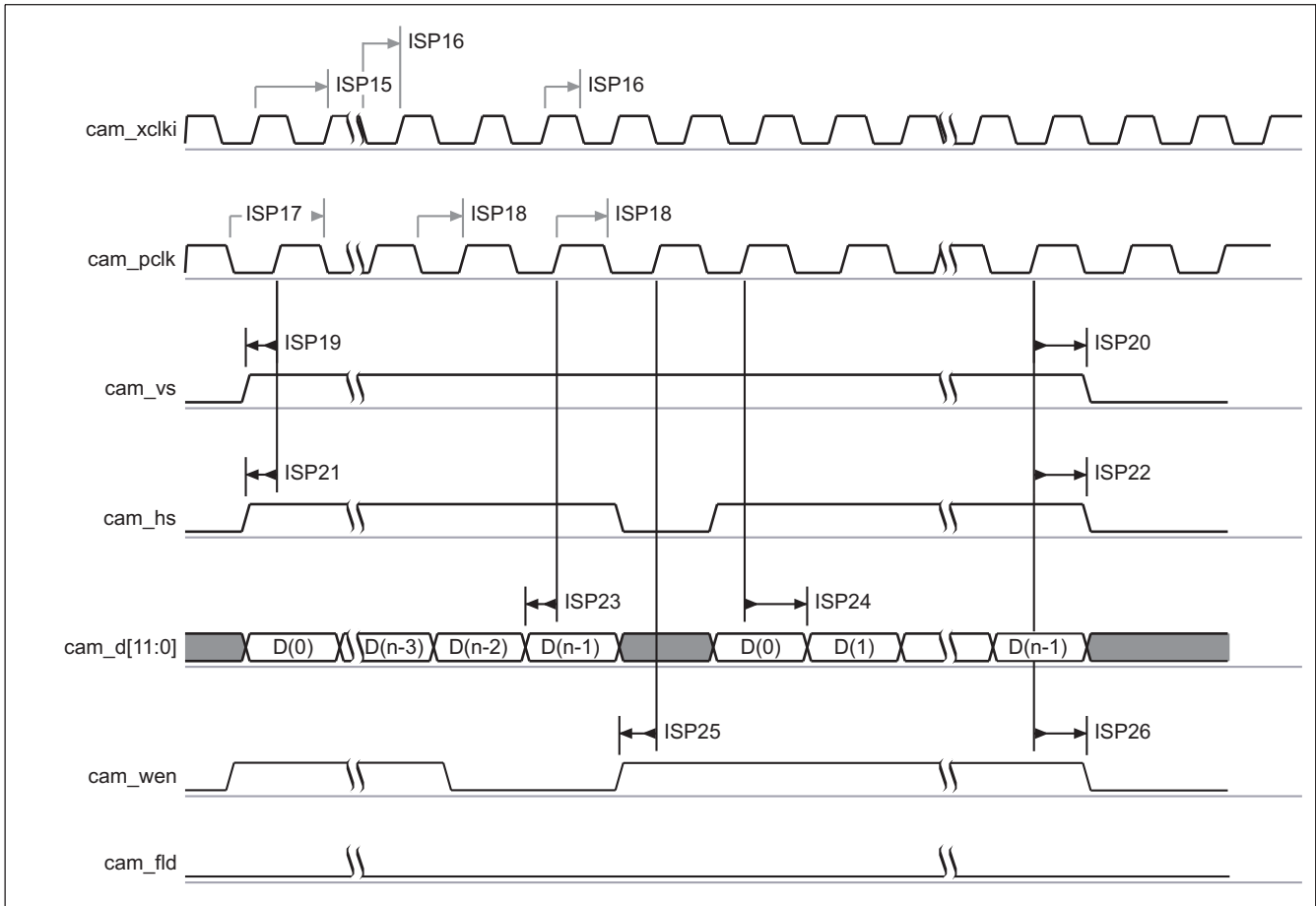

030-056

Figure 6-23. ISP – 12-Bit SYNC Normal – Progressive Mode⁽¹⁾⁽²⁾⁽³⁾⁽⁴⁾⁽⁵⁾⁽⁶⁾⁽⁷⁾⁽⁸⁾

- (1) The polarity of cam_pclk, cam_fld, cam_vs, and cam_hs are configurable. If the cam_hs, cam_vs, and cam_fld signals are output, the signal length can be set.
- (2) The parallel camera in SYNC mode supports progressive image sensor modules and 8-, 10-, 11-, or 12-bit data.
- (3) When the image sensor has fewer than 12 data lines, it must be connected to the lower data lines and the unused lines must be grounded.
- (4) However, it is possible to shift the data to 0, 2, or 4 data internal lanes.
- (5) The bit configurations are: cam_d[11:4] or cam_d[7:0] in 8-bit mode, cam_d[11:2] or cam_d[9:0] in 10-bit mode, cam_d[10:0] in 11-bit mode, and cam_d[11:0] in 12-bit mode.
- (6) Optionally, the data write to memory can be qualified by the external cam_wen signal.
- (7) The cam_wen signal can be used as a external memory write-enable signal. The data is stored to memory only if cam_hs, cam_vs, and cam_wen signals are asserted.
- (8) In cam_xclki; I is equal to a or b.

6.5.1.1.1.2 8-bit Packed SYNC – Progressive Mode

Table 6-26 and Table 6-27 assume testing over the recommended operating conditions and electrical characteristic conditions (see Figure 6-24).

Table 6-25. ISP Timing Conditions – 8-bit Packed SYNC – Progressive Mode

| TIMING CONDITION PARAMETER | | VALUE | UNIT |
|----------------------------|------------------------|-------|------|
| Input Conditions | | | |
| t _R | Input signal rise time | 2.5 | ns |
| t _F | Input signal fall time | 2.5 | ns |
| Output Conditions | | | |

Table 6-25. ISP Timing Conditions – 8-bit Packed SYNC – Progressive Mode (continued)

| TIMING CONDITION PARAMETER | | VALUE | UNIT |
|----------------------------|-------------------------|-------|------|
| C _{LOAD} | Output load capacitance | 8.6 | pF |

Table 6-26. ISP Timing Requirements – 8-bit Packed SYNC – Progressive Mode⁽¹⁾

| NO. | PARAMETER | | 1.15 V | | 1.0 V | | UNIT |
|-------|----------------------------|---|----------------------|-----|----------------------|-----|------|
| | | | MIN | MAX | MIN | MAX | |
| ISP3 | t _c (pclk) | Cycle time ⁽²⁾ , cam_pclk period | 7.7 | | 15.4 | | ns |
| ISP4 | t _W (pclkH) | Typical pulse duration, cam_pclk high | 0.5*P ⁽³⁾ | | 0.5*P ⁽³⁾ | | ns |
| ISP4 | t _W (pclkL) | Typical pulse duration, cam_pclk low | 0.5*P ⁽³⁾ | | 0.5*P ⁽³⁾ | | ns |
| | t _{dc} (pclk) | Duty cycle error, cam_pclk | | 385 | | 769 | ps |
| | t _j (pclk) | Cycle jitter ⁽⁴⁾ , cam_pclk | | 83 | | 167 | ps |
| ISP5 | t _{su} (dV-pclkH) | Setup time, cam_d[11:0] valid before cam_pclk rising edge | 1.08 | | 2.27 | | ns |
| ISP6 | t _h (pclkH-dV) | Hold time, cam_d[11:0] valid after cam_pclk rising edge | 1.08 | | 2.27 | | ns |
| ISP7 | t _{su} (dV-vsH) | Setup time, cam_vs valid before cam_pclk rising edge | 1.08 | | 2.27 | | ns |
| ISP8 | t _h (pclkH-vsV) | Hold time, cam_vs valid after cam_pclk rising edge | 1.08 | | 2.27 | | ns |
| ISP9 | t _{su} (dV-hsH) | Setup time, cam_hs valid before cam_pclk rising edge | 1.08 | | 2.27 | | ns |
| ISP10 | t _h (pclkH-hsV) | Hold time, cam_hs valid after cam_pclk rising edge | 1.08 | | 2.27 | | ns |
| ISP11 | t _{su} (dV-hsH) | Setup time, cam_wen valid before cam_pclk rising edge | 1.08 | | 2.27 | | ns |
| ISP12 | t _h (pclkH-hsV) | Hold time, cam_wen valid after cam_pclk rising edge | 1.08 | | 2.27 | | ns |

(1) The timing requirements are assured for the cycle jitter and duty cycle error conditions specified.

(2) Related with the input maximum frequency supported by the ISP module.

(3) P = cam_pclk period in ns.

(4) Maximum cycle jitter supported by cam_pclk input clock.

Table 6-27. ISP Switching Characteristics – 8-bit packed SYNC – Progressive Mode

| NO. | PARAMETER | | 1.15 V | | 1.0 V | | UNIT |
|------|------------------------|---|-----------------------|------|-----------------------|------|------|
| | | | MIN | MAX | MIN | MAX | |
| ISP1 | t _c (xclk) | Cycle time ⁽¹⁾ , cam_xclk period | 4.6 | | 4.6 | | ns |
| ISP2 | t _W (xclkH) | Typical pulse duration, cam_xclk high | 0.5*PO ⁽²⁾ | | 0.5*PO ⁽²⁾ | | ns |
| ISP2 | t _W (xclkL) | Typical pulse duration, cam_xclk low | 0.5*PO ⁽²⁾ | | 0.5*PO ⁽²⁾ | | ns |
| | t _{dc} (xclk) | Duty cycle error, cam_xclk | | 231 | | 231 | ps |
| | t _j (xclk) | Jitter standard deviation ⁽³⁾ , cam_xclk | | 67 | | 67 | ps |
| | t _R (xclk) | Rise time, cam_xclk | | 0.93 | | 0.93 | ns |
| | t _F (xclk) | Fall time, cam_xclk | | 0.93 | | 0.93 | ns |

(1) Related with the cam_xclk maximum and minimum frequencies programmable in the ISP module.

Warning: You must disable the camera sensor or the camera module to change the frequency configuration. For more information, see the *OMAP35x Technical Reference Manual (TRM)* [literature number [SPRUJ98](#)]

(2) PO = cam_xclk period in ns

(3) The jitter probability density can be approximated by a Gaussian function.

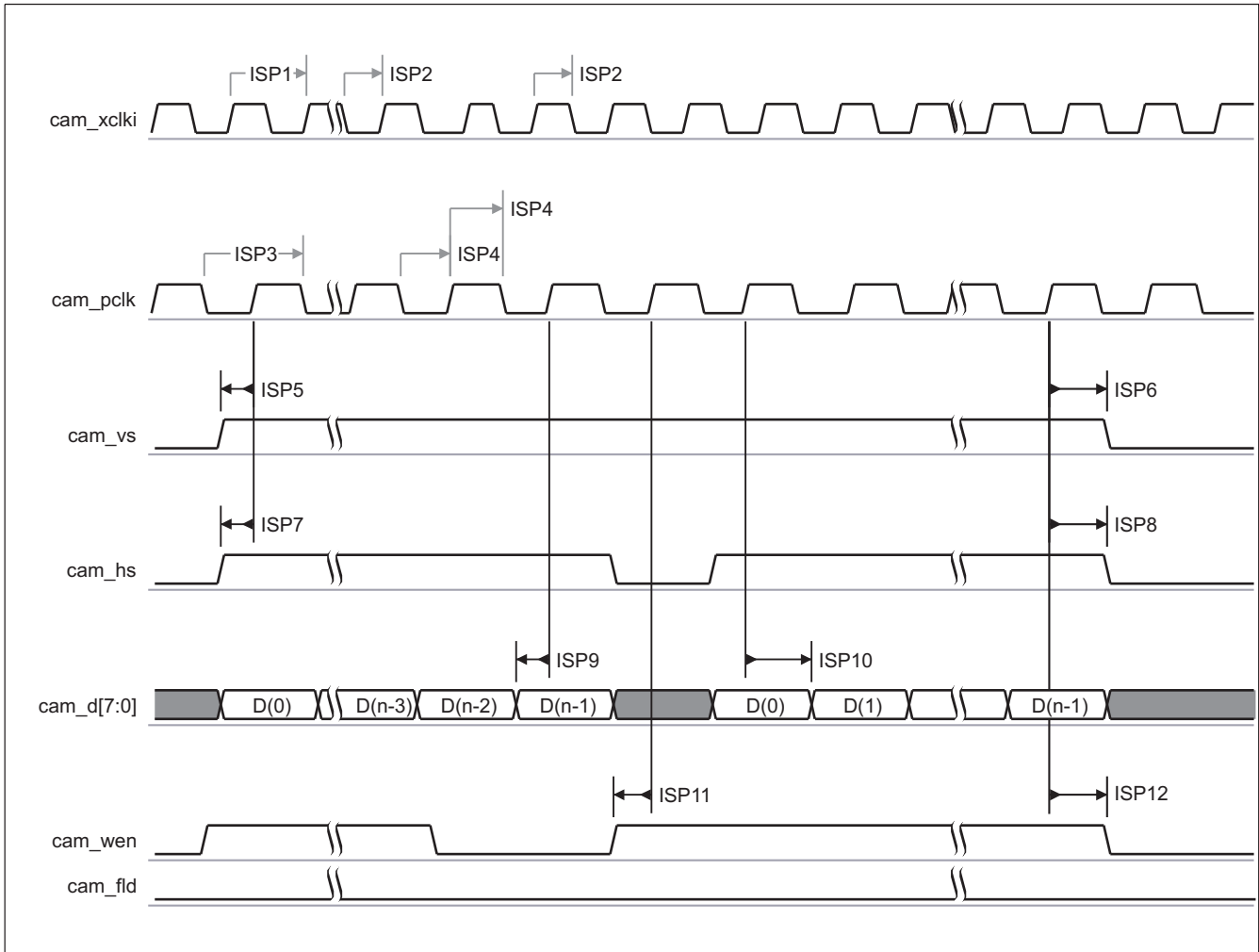

030-059

Figure 6-24. ISP – 8-bit Packed SYNC – Progressive Mode⁽¹⁾⁽²⁾⁽³⁾⁽⁴⁾⁽⁵⁾

- (1) The polarity of cam_pclk, cam_fld, cam_vs, and cam_hs are configurable.
- (2) The image sensor must be connected to the lower data lines and the unused lines must be grounded. However, it is possible to shift the data to 0, 2, or 4 data internal lanes. The bit configurations are: cam_d[11:4] or cam_d[7:0] in 8-bit packed mode.
- (3) Optionally, the data write to memory can be qualified by the external cam_wen signal. The cam_wen signal can be used as a external memory write-enable signal. The data is stored to memory only if cam_hs, cam_vs, and cam_wen signals are asserted. The polarity of cam_fld is programmable.
- (4) The camera module can pack 8-bit data into 16 bits. It doubles the maximum pixel clock. This mode can be particularly useful to transfer a YCbCr data stream or compressed stream to memory at very high speed.
- (5) In cam_xclki; I is equal to a or b.

6.5.1.1.1.3 12-Bit SYNC Normal – Interlaced Mode

Table 6-29 and Table 6-30 assume testing over the recommended operating conditions and electrical characteristic conditions (see Figure 6-25).

Table 6-28. ISP Timing Conditions – 12-Bit SYNC Normal – Interlaced Mode

| TIMING CONDITION PARAMETER | | VALUE | UNIT |
|----------------------------|------------------------|-------|------|
| Input Conditions | | | |
| t _R | Input signal rise time | 2.7 | ns |
| t _F | Input signal fall time | 2.7 | ns |
| Output Conditions | | | |

Table 6-28. ISP Timing Conditions – 12-Bit SYNC Normal – Interlaced Mode (continued)

| TIMING CONDITION PARAMETER | | VALUE | UNIT |
|----------------------------|-------------------------|-------|------|
| C _{LOAD} | Output load capacitance | 8.6 | pF |

Table 6-29. ISP Timing Requirements – 12-Bit SYNC Normal – Interlaced Mode⁽¹⁾

| NO. | PARAMETER | | 1.15 V | | 1.0 V | | UNIT |
|-------|-----------------------------|---|----------------------|-----|----------------------|------|------|
| | | | MIN | MAX | MIN | MAX | |
| ISP17 | t _c (pclk) | Cycle time ⁽²⁾ , cam_pclk period | 13.3 | | 22.2 | | ns |
| ISP18 | t _W (pclkH) | Typical pulse duration, cam_pclk high | 0.5*P ⁽³⁾ | | 0.5*P ⁽³⁾ | | ns |
| ISP18 | t _W (pclkL) | Typical pulse duration, cam_pclk low | 0.5*P ⁽³⁾ | | 0.5*P ⁽³⁾ | | ns |
| | t _{dc} (pclk) | Duty cycle error, cam_pclk | | 667 | | 1111 | ps |
| | t _j (pclk) | Cycle jitter ⁽⁴⁾ , cam_pclk | | 133 | | 200 | ps |
| ISP19 | t _{su} (dV-pclkH) | Setup time, cam_d[11:0] valid before cam_pclk rising edge | 1.82 | | 3.25 | | ns |
| ISP20 | t _h (pclkH-dV) | Hold time, cam_d[11:0] valid after cam_pclk rising edge | 1.82 | | 3.25 | | ns |
| ISP21 | t _{su} (dV-vsH) | Setup time, cam_vs valid before cam_pclk rising edge | 1.82 | | 3.25 | | ns |
| ISP22 | t _h (pclkH-vsV) | Hold time, cam_vs valid after cam_pclk rising edge | 1.82 | | 3.25 | | ns |
| ISP23 | t _{su} (dV-hsH) | Setup time, cam_hs valid before cam_pclk rising edge | 1.82 | | 3.25 | | ns |
| ISP24 | t _h (pclkH-hsV) | Hold time, cam_hs valid after cam_pclk rising edge | 1.82 | | 3.25 | | ns |
| ISP25 | t _{su} (dV-hsH) | Setup time, cam_wen valid before cam_pclk rising edge | 1.82 | | 3.25 | | ns |
| ISP26 | t _h (pclkH-hsV) | Hold time, cam_wen valid after cam_pclk rising edge | 1.82 | | 3.25 | | ns |
| ISP27 | t _{su} (dV-fldH) | Setup time, cam_fld valid before cam_pclk rising edge | 1.82 | | 3.25 | | ns |
| ISP28 | t _h (pclkH-fldV) | Hold time, cam_fld valid after cam_pclk rising edge | 1.82 | | 3.25 | | ns |

(1) The timing requirements are assured for the cycle jitter and duty cycle error conditions specified.

(2) Related with the input maximum frequency supported by the ISP module.

(3) P = cam_lclk period in ns.

(4) Maximum cycle jitter supported by cam_pclk input clock.

Table 6-30. ISP Switching Characteristics – 12-Bit SYNC Normal – Interlaced Mode

| NO. | PARAMETER | | 1.15 V | | 1.0 V | | UNIT |
|-------|------------------------|---|-----------------------|------|-----------------------|------|------|
| | | | MIN | MAX | MIN | MAX | |
| ISP15 | t _c (xclk) | Cycle time ⁽¹⁾ , cam_xclk period | 4.6 | | 4.6 | | ns |
| ISP16 | t _W (xclkH) | Typical pulse duration, cam_xclk high | 0.5*PO ⁽²⁾ | | 0.5*PO ⁽²⁾ | | ns |
| ISP16 | t _W (xclkL) | Typical pulse duration, cam_xclk low | 0.5*PO ⁽²⁾ | | 0.5*PO ⁽²⁾ | | ns |
| | t _{dc} (xclk) | Duty cycle error, cam_xclk | | 231 | | 231 | ps |
| | t _j (xclk) | Jitter standard deviation ⁽³⁾ , cam_xclk | | 33 | | 33 | ps |
| | t _R (xclk) | Rise time, cam_xclk | | 0.93 | | 0.93 | ns |
| | t _F (xclk) | Fall time, cam_xclk | | 0.93 | | 0.93 | ns |

(1) Related with the cam_xclk maximum and minimum frequencies programmable in the ISP module.

Warning: You must disable the camera sensor or the camera module to change the frequency configuration. For more information, see the *OMAP35x Technical Reference Manual (TRM)* [literature number [SPRUF98](#)]

(2) PO = cam_xclk period in ns.

(3) The jitter probability density can be approximated by a Gaussian function.

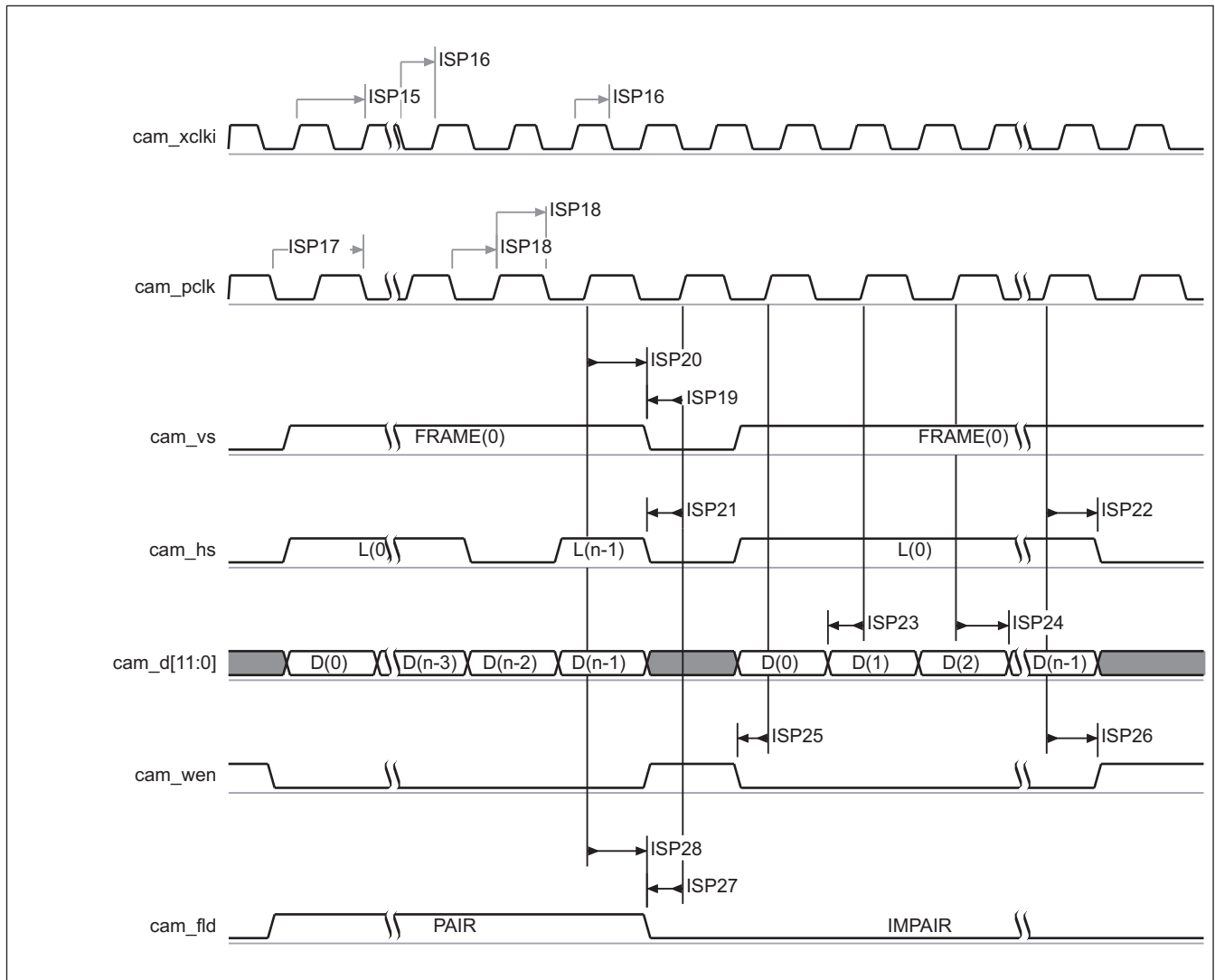

030-057

Figure 6-25. ISP – 12-Bit SYNC Normal – Interlaced Mode⁽¹⁾⁽²⁾⁽³⁾⁽⁴⁾⁽⁵⁾⁽⁶⁾⁽⁷⁾⁽⁸⁾

- (1) The polarity of cam_pclk, cam_fld, cam_vs, and cam_hs are configurable. If the cam_hs, cam_vs, and cam_fld signals are output, the signal length can be set.
- (2) The parallel camera in SYNC mode supports interlaced image sensor modules and 8-, 10-, 11-, or 12-bit data.
- (3) When the image sensor has fewer than 12 data lines, it must be connected to the lower data lines and the unused lines must be grounded.
- (4) It is possible to shift the data to 0, 2, or 4 data internal lanes.
- (5) The bit configurations are: cam_d[11:4] or cam_d[7:0] in 8-bit mode, cam_d[11:2] or cam_d[9:0] in 10-bit mode, cam_d[10:0] in 11-bit mode, and cam_d[11:0] in 12-bit mode.
- (6) Optionally, the data write to memory can be qualified by the external cam_wen signal.
- (7) The cam_wen signal can be used as a external memory write-enable signal. The data is stored to memory only if cam_hs, cam_vs, and cam_wen signals are asserted.
- (8) In cam_xclki; I is equal to a or b.

6.5.1.1.1.4 8-bit Packed SYNC – Interlaced Mode

Table 6-32 and Table 6-33 assume testing over the recommended operating conditions and electrical characteristic conditions (see Figure 6-26).

Table 6-31. ISP Timing Conditions – 8-bit Packed SYNC – Interlaced Mode

| TIMING CONDITION PARAMETER | | VALUE | UNIT |
|----------------------------|-------------------------|-------|------|
| Input Conditions | | | |
| t_R | Input signal rise time | 2.5 | ns |
| t_F | Input signal fall time | 2.5 | ns |
| Output Conditions | | | |
| C_{LOAD} | Output load capacitance | 8.6 | pF |

Table 6-32. ISP Timing Requirements – 8-bit Packed SYNC – Interlaced Mode⁽¹⁾

| NO. | PARAMETER | | 1.15 V | | 1.0 V | | UNIT |
|-------|---------------------|---|----------------------|-----|----------------------|-----|------|
| | | | MIN | MAX | MIN | MAX | |
| ISP3 | $t_{c(plk)}$ | Cycle time ⁽²⁾ , cam_pclk period | 7.7 | | 15.4 | | ns |
| ISP4 | $t_{W(plkH)}$ | Typical pulse duration, cam_pclk high | 0.5*P ⁽³⁾ | | 0.5*P ⁽³⁾ | | ns |
| ISP4 | $t_{W(plkL)}$ | Typical pulse duration, cam_pclk low | 0.5*P ⁽³⁾ | | 0.5*P ⁽³⁾ | | ns |
| | $t_{dc(plk)}$ | Duty cycle error, cam_pclk | | 385 | | 769 | ps |
| | $t_{j(plk)}$ | Cycle jitter ⁽⁴⁾ , cam_pclk | | 83 | | 167 | ps |
| ISP5 | $t_{su(dV-plkH)}$ | Setup time, cam_d[11:0] valid before cam_pclk rising edge | 1.08 | | 2.27 | | ns |
| ISP6 | $t_{h(plkH-dV)}$ | Hold time, cam_d[11:0] valid after cam_pclk rising edge | 1.08 | | 2.27 | | ns |
| ISP7 | $t_{su(dV-vsH)}$ | Setup time, cam_vs valid before cam_pclk rising edge | 1.08 | | 2.27 | | ns |
| ISP8 | $t_{h(plkH-vsV)}$ | Hold time, cam_vs valid after cam_pclk rising edge | 1.08 | | 2.27 | | ns |
| ISP9 | $t_{su(dV-hsH)}$ | Setup time, cam_hs valid before cam_pclk rising edge | 1.08 | | 2.27 | | ns |
| ISP10 | $t_{h(plkH-hsV)}$ | Hold time, cam_hs valid after cam_pclk rising edge | 1.08 | | 2.27 | | ns |
| ISP11 | $t_{su(dV-hsH)}$ | Setup time, cam_wen valid before cam_pclk rising edge | 1.08 | | 2.27 | | ns |
| ISP12 | $t_{h(plkH-hsV)}$ | Hold time, cam_wen valid after cam_pclk rising edge | 1.08 | | 2.27 | | ns |
| ISP13 | $t_{su(dV-flidH)}$ | Setup time, cam_fld valid before cam_pclk rising edge | 1.08 | | 2.27 | | ns |
| ISP14 | $t_{h(plkH-flidV)}$ | Hold time, cam_fld valid after cam_pclk rising edge | 1.08 | | 2.27 | | ns |

(1) The timing requirements are assured for the cycle jitter and duty cycle error conditions specified.

(2) Related with the input maximum frequency supported by the ISP module.

(3) P = cam_lclk period in ns.

(4) Maximum cycle jitter supported by cam_pclk input clock.

Table 6-33. ISP Switching Characteristics – 8-bit Packed SYNC – Interlaced Mode

| NO. | PARAMETER | | 1.15 V | | 1.0 V | | UNIT |
|-------|----------------|---|-----------------------|------|-----------------------|------|------|
| | | | MIN | MAX | MIN | MAX | |
| ISP16 | $t_{c(xclk)}$ | Cycle time ⁽¹⁾ , cam_xclk period | 4.6 | | 4.6 | | ns |
| ISP2 | $t_{W(xclkH)}$ | Typical pulse duration, cam_xclk high | 0.5*PO ⁽²⁾ | | 0.5*PO ⁽²⁾ | | ns |
| ISP2 | $t_{W(xclkL)}$ | Typical pulse duration, cam_xclk low | 0.5*PO ⁽²⁾ | | 0.5*PO ⁽²⁾ | | ns |
| | $t_{dc(xclk)}$ | Duty cycle error, cam_xclk | | 231 | | 231 | ps |
| | $t_{j(xclk)}$ | Jitter standard deviation ⁽³⁾ , cam_xclk | | 67 | | 67 | ps |
| | $t_{R(xclk)}$ | Rise time, cam_xclk | | 0.93 | | 0.93 | ns |
| | $t_{F(xclk)}$ | Fall time, cam_xclk | | 0.93 | | 0.93 | ns |

(1) Related with the cam_xclk maximum and minimum frequencies programmable in the ISP module.

Warning: You must disable the camera sensor or the camera module to change the frequency configuration. For more information, see the *OMAP35x Technical Reference Manual (TRM)* [literature number [SPRUJ98](#)]

(2) PO = cam_xclk period in ns.

(3) The jitter probability density can be approximated by a Gaussian function.

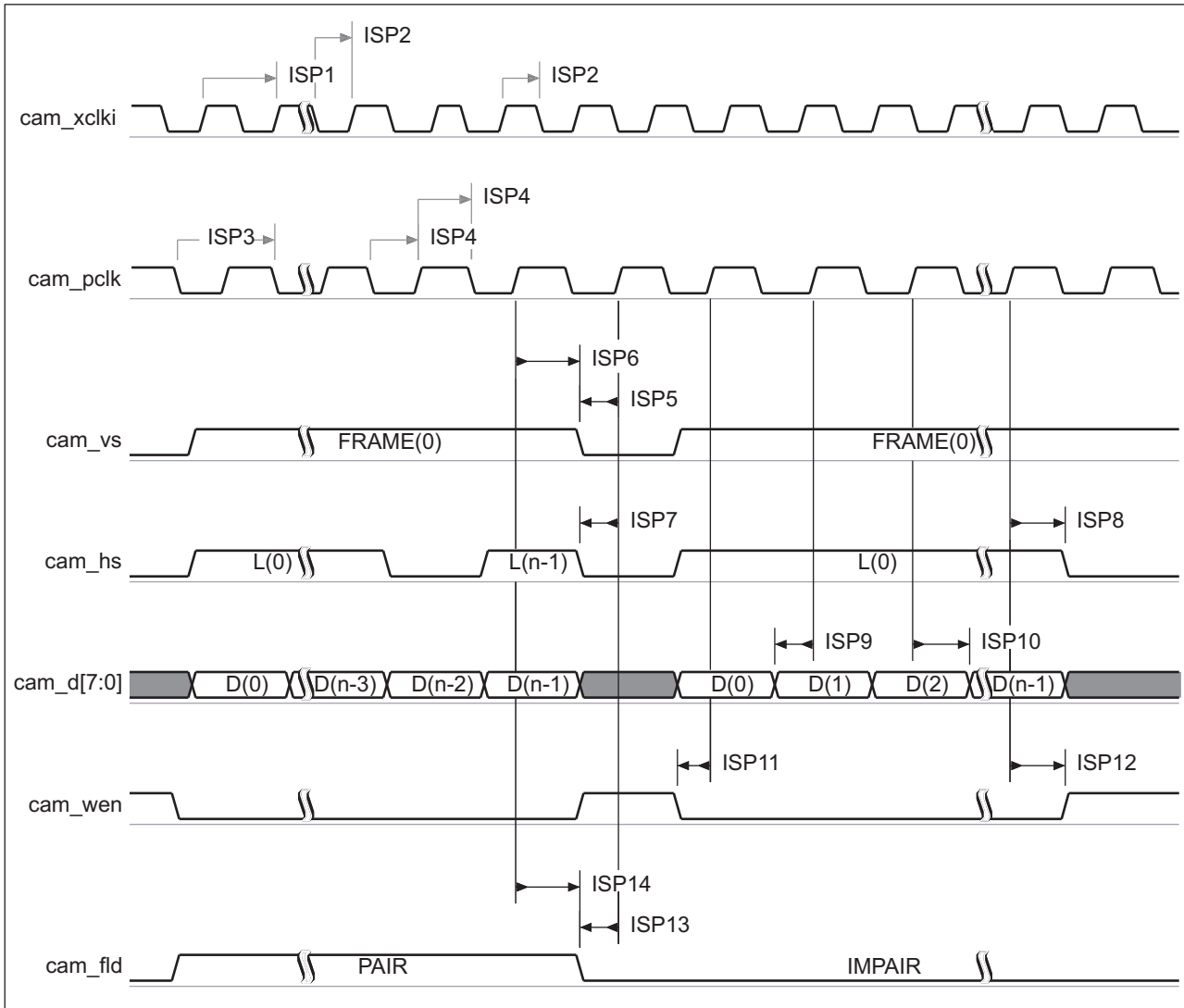

030-060

Figure 6-26. ISP – 8-bit Packed SYNC – Interlaced Mode⁽¹⁾⁽²⁾⁽³⁾⁽⁴⁾⁽⁵⁾

- (1) The polarity of cam_pclk, cam_fld, cam_vs, and cam_hs are configurable.
- (2) The image sensor must be connected to the lower data lines and the unused lines must be grounded. However, it is possible to shift the data to 0, 2, or 4 data internal lanes. The bit configurations are: cam_d[11:4] or cam_d[7:0] in 8-bit packed mode.
- (3) Optionally, the data write to memory can be qualified by the external cam_wen signal. The cam_wen signal can be used as a external memory write-enable signal. The data is stored to memory only if cam_hs, cam_vs, and cam_wen signals are asserted.
- (4) The camera module can pack 8-bit data into 16 bits. It doubles the maximum pixel clock. This mode can be particularly useful to transfer a YCbCr data stream or compressed stream to memory at very high speed.
- (5) In cam_xclki; I is equal to a or b.

6.5.1.1.2 ITU Mode

Table 6-35 and Table 6-36 assume testing over the recommended operating conditions and electrical characteristic conditions (see Figure 6-27).

Table 6-34. ISP Timing Conditions – ITU Mode

| TIMING CONDITION PARAMETER | | VALUE | UNIT |
|----------------------------|------------------------|-------|------|
| Input Conditions | | | |
| t _R | Input signal rise time | 2.7 | ns |

Table 6-34. ISP Timing Conditions – ITU Mode (continued)

| TIMING CONDITION PARAMETER | | VALUE | UNIT |
|----------------------------|-------------------------|-------|------|
| t_F | Input signal fall time | 2.7 | ns |
| Output Conditions | | | |
| C_{LOAD} | Output load capacitance | 8.6 | pF |

Table 6-35. ISP Timing Requirements – ITU Mode⁽¹⁾

| NO. | PARAMETER | | 1.15 V | | 1.0 V | | UNIT |
|-------|--------------------|--|----------------------|-----|----------------------|------|------|
| | | | MIN | MAX | MIN | MAX | |
| ISP17 | $t_{c(pclk)}$ | Cycle time ⁽²⁾ , cam_pclk period | 13.3 | | 22.2 | | ns |
| ISP18 | $t_{W(pclkH)}$ | Typical pulse duration, cam_pclk high | 0.5*P ⁽³⁾ | | 0.5*P ⁽³⁾ | | ns |
| ISP18 | $t_{W(pclkL)}$ | Typical pulse duration, cam_pclk low | 0.5*P ⁽³⁾ | | 0.5*P ⁽³⁾ | | ns |
| | $t_{dc(pclk)}$ | Duty cycle error, cam_pclk | | 667 | | 1111 | ps |
| | $t_{j(pclk)}$ | Cycle jitter ⁽⁴⁾ , cam_pclk | | 133 | | 200 | ps |
| ISP23 | $t_{su(dV-pclkH)}$ | Setup time, cam_d[9:0] valid before cam_pclk rising edge | 1.82 | | 3.25 | | ns |
| ISP24 | $t_{h(pclkH-dV)}$ | Hold time, cam_d[9:0] valid after cam_pclk rising edge | 1.82 | | 3.25 | | ns |

- (1) The timing requirements are assured for the cycle jitter and duty cycle error conditions specified.
(2) Related with the input maximum frequency supported by the ISP module.
(3) P = cam_lclk period in ns.
(4) Maximum cycle jitter supported by cam_lclk input clock.

Table 6-36. ISP Switching Characteristics – ITU Mode

| NO. | PARAMETER | | 1.15 V | | 1.0 V | | UNIT |
|-------|----------------|---|-----------------------|------|-----------------------|------|------|
| | | | MIN | MAX | MIN | MAX | |
| ISP15 | $t_{c(xclk)}$ | Cycle time ⁽¹⁾ , cam_xclk period | 4.6 | | 4.6 | | ns |
| ISP16 | $t_{W(xclkH)}$ | Typical pulse duration, cam_xclk high | 0.5*PO ⁽²⁾ | | 0.5*PO ⁽²⁾ | | ns |
| ISP16 | $t_{W(xclkL)}$ | Typical pulse duration, cam_xclk low | 0.5*PO ⁽²⁾ | | 0.5*PO ⁽²⁾ | | ns |
| | $t_{dc(xclk)}$ | Duty cycle error, cam_xclk | | 231 | | 231 | ps |
| | $t_{j(xclk)}$ | Jitter standard deviation ⁽³⁾ , cam_xclk | | 33 | | 33 | ps |
| | $t_{R(xclk)}$ | Rise time, cam_xclk | | 0.93 | | 0.93 | ns |
| | $t_{F(xclk)}$ | Fall time, cam_xclk | | 0.93 | | 0.93 | ns |

- (1) Related with the cam_xclk maximum and minimum frequencies programmable in the ISP module.
Warning: The camera sensor or the camera module must be disabled to change the frequency configuration. For more information, see the *OMAP35x Technical Reference Manual (TRM)* [literature number [SPRUJ98](#)]
(2) PO = cam_xclk period in ns
(3) The jitter probability density can be approximated by a Gaussian function.

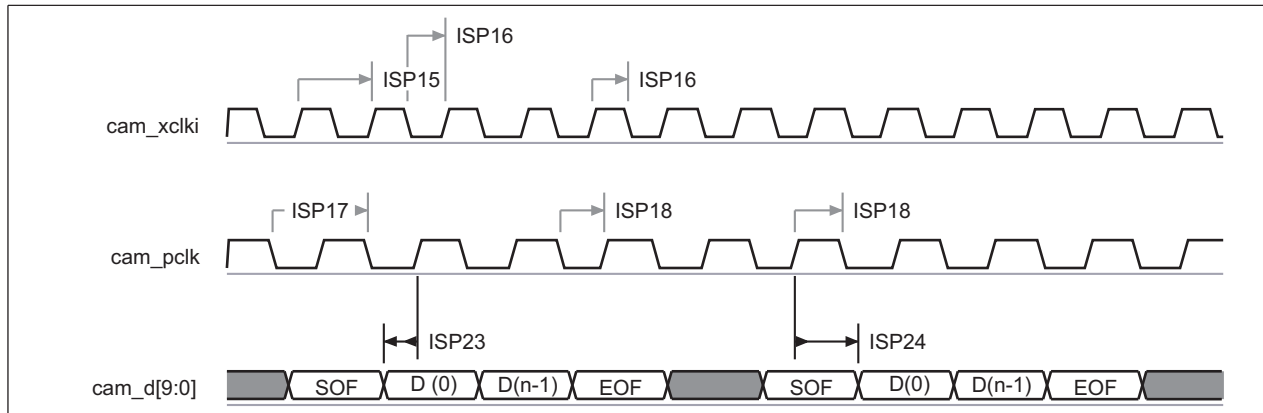

030-058

Figure 6-27. ISP – ITU Mode⁽¹⁾⁽²⁾

- (1) The unused lines must be grounded and the data bus must be connected to the lower data lines. It is possible to shift the data to 0, 2, or 4 data internal lanes. The different configurations are: cam_d[11:4] or cam_d[7:0] in 8-bit mode and cam_d[11:2] or cam_d[9:0] in 10-bit mode.
- (2) The parallel camera in ITU mode supports progressive camera modules.

6.5.2 Display Subsystem (DSS)

The display subsystem (DSS) provides the logic to display the video frame from external (SDRAM) or internal (SRAM) memory on an LCD panel or a TV set. The DSS integrates a display controller, a remote frame buffer module (RFBI), and a TV-out module. It can be used in two configurations:

- LCD display in:
 - Bypass mode (RFBI module bypassed)
 - RFBI mode (through RFBI module)
- TV display (not discussed in this document because of its analog IO signals)

The two displays can be active at the same time.

NOTE

For more information, see Display Subsystem / Display Subsystem Functional Description section of the *OMAP35x Technical Reference Manual (TRM)* [literature number [SPRU98](#)].

6.5.2.1 LCD Display in Bypass Mode

Two types of LCD panel are supported:

- Thin film transistor (TFT) or active matrix technology
- Supertwisted nematic (STN) or passive matrix technology

Both configurations are discussed in the following paragraphs.

6.5.2.1.1 LCD Display in TFT Mode

6.5.2.1.1.1 LCD Display in TFT Mode – HDTV Application

[Table 6-37](#) assumes testing over the recommended operating conditions (see [Figure 6-28](#)).

Table 6-37. LCD Display Switching Characteristics in TFT Mode – HDTV Application⁽³⁾⁽⁴⁾

| NO. | PARAMETER | | OPP3 | | OPP2 | | UNIT |
|-----|------------------------|---|----------------------|----------------------|----------------------|----------------------|------|
| | | | MIN | MAX | MIN | MAX | |
| DL0 | $t_{d(PCLKA-HSYNCT)}$ | Delay time, dss_pclk active edge to dss_hsync transition | –4.2 | 4.2 | –4.7 | 4.7 | ns |
| DL1 | $t_{d(PCLKA-VSYNCT)}$ | Delay time, dss_pclk active edge to dss_vsync transition | –4.2 | 4.2 | –4.7 | 4.7 | ns |
| DL2 | $t_{d(PCLKA-ACBIASA)}$ | Delay time, dss_pclk active edge to dss_acbias active level | –4.2 | 4.2 | –4.7 | 4.7 | ns |
| DL3 | $t_{d(PCLKA-DATAV)}$ | Delay time, dss_pclk active edge to dss_data bus valid | –4.2 | 4.2 | –4.7 | 4.7 | ns |
| DL4 | $t_{c(PCLK)}$ | Cycle time ⁽²⁾ , dss_pclk | 13.468 | | 15.152 | | ns |
| DL5 | $t_{w(PCLK)}$ | Pulse duration, dss_pclk low or high | $0.45 \cdot P^{(1)}$ | $0.55 \cdot P^{(1)}$ | $0.45 \cdot P^{(1)}$ | $0.55 \cdot P^{(1)}$ | ns |

(1) P = dss_pclk period.

(2) The pixel clock frequency is software programmable via the pixel clock divider configuration from 1 to 255 division range in the DISPC_DIVISOR register.

(3) The capacitive load is equivalent to 25 pF at 1.15 V and 30 pF at 1.0 V.

(4) For more information, see the DSS chapter in the *OMAP35x Technical Reference Manual (TRM)* [literature number [SPRU98](#)].

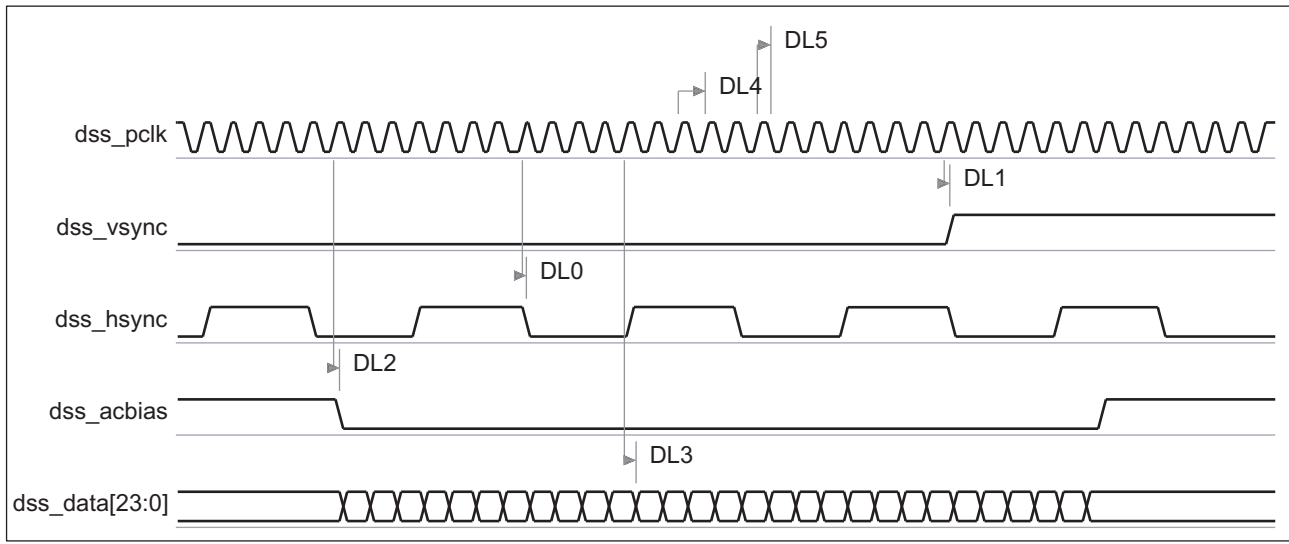

030-061

Figure 6-28. LCD Display in TFT Mode – HDTV Application⁽¹⁾⁽²⁾⁽³⁾⁽⁴⁾

- (1) The pixel data bus depends on the use of 8-, 9-, 12-, 16-, 18-, or 24-bit per pixel data output pins.
- (2) The pixel clock frequency is programmable.
- (3) All timings not illustrated in the waveform are programmable by software, control signal polarity, and driven edge of dss_pclk.
- (4) For more information, see the DSS chapter in the *OMAP35x Technical Reference Manual (TRM)* [literature number [SPRUF98](#)].

6.5.2.1.2 LCD Display in STN Mode

[Table 6-38](#) assumes testing over the recommended operating conditions (see [Figure 6-29](#)).

Table 6-38. LCD Display Switching Characteristics in STN Mode⁽³⁾⁽⁴⁾⁽⁵⁾

| NO. | PARAMETER | | OPP3 | | OPP2 | | UNIT |
|-----|----------------------|--|----------------------|----------------------|----------------------|----------------------|------|
| | | | MIN | MAX | MIN | MAX | |
| DL3 | $t_{d(PCLKA-DATAV)}$ | Delay time, dss_pclk active edge to dss_data bus valid | -6.9 | 6.9 | -6.9 | 6.9 | ns |
| DL4 | $t_{c(PCLK)}$ | Cycle time ⁽²⁾ , dss_pclk | 22.727 | | 22.727 | | ns |
| DL5 | $t_{w(PCLK)}$ | Pulse duration, dss_pclk low or high | $0.45 \cdot P^{(1)}$ | $0.55 \cdot P^{(1)}$ | $0.45 \cdot P^{(1)}$ | $0.55 \cdot P^{(1)}$ | ns |

- (1) P = dss_pclk period.
- (2) The pixel clock frequency is software programmable via the pixel clock divider configuration from 1 to 255 division range in the DISPC_DIVISOR register.
- (3) The DSS in STN mode is used with 4 or 8 pins only; unused pixel data bits always remain low.
- (4) The capacitive load is equivalent to 40 pF.
- (5) For more information, see the DSS chapter in the *OMAP35x Technical Reference Manual (TRM)* [literature number [SPRUF98](#)].

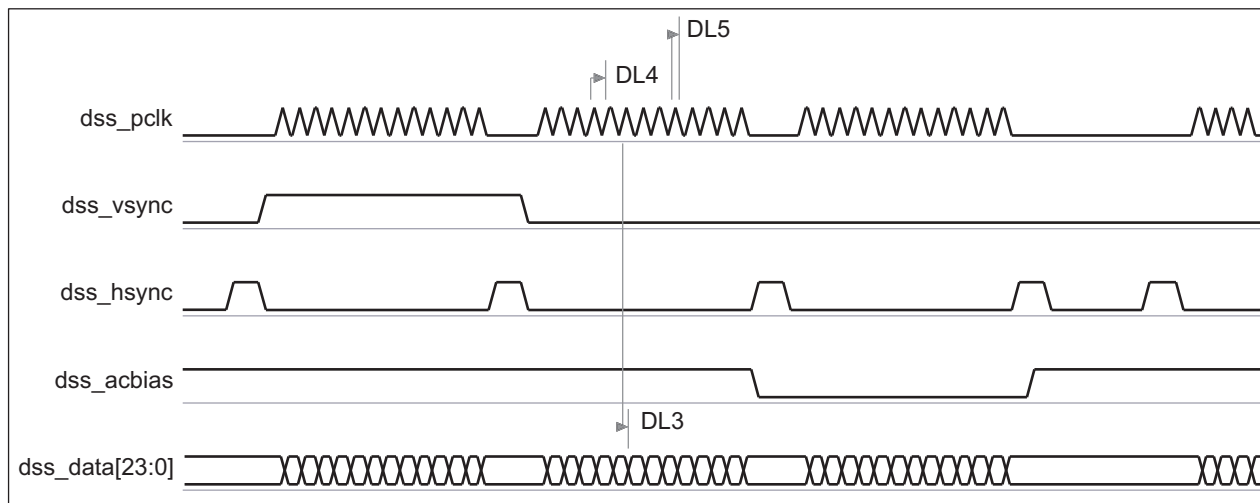

030-062

Figure 6-29. LCD Display in STN Mode⁽¹⁾⁽²⁾⁽³⁾⁽⁴⁾⁽⁵⁾

- (1) The pixel data bus depends on the use 4-, 8-, 12-, 16-, 18-, or 24-bit per pixel data output pins.
- (2) All timings not illustrated in the waveform are programmable by software, control signal polarity, and driven edge of dss_pclk.
- (3) dss_vsync width must be programmed to be as small as possible.
- (4) The pixel clock frequency is programmable.
- (5) For more information, see the DSS chapter in the *OMAP35x Technical Reference Manual (TRM)* [literature number [SPRU98](#)].

6.5.2.2 LCD Display in RFBI Mode

Table 6-40 and Table 6-41 assume testing over the recommended operating conditions (see Figure 6-30 through Figure 6-32).

Table 6-39. LCD Timing Conditions – RFBI Mode

| TIMING CONDITION PARAMETER | | VALUE | | UNIT |
|----------------------------|-------------------------|-------|-----|------|
| | | MIN | MAX | |
| Input Conditions | | | | |
| t_R | Input signal rise time | | 15 | ns |
| t_F | Input signal fall time | | 15 | ns |
| Output Conditions | | | | |
| C_{LOAD} | Output load capacitance | | 30 | pF |

Table 6-40. LCD Display Timing Requirements in RFBI Mode

| NO. | PARAMETER | | OPP3 | | OPP2 | | OPP1 ⁽¹⁾ | | UNIT |
|-----|----------------------------|---|------------------|-----|------------------|-----|---------------------|-----|------|
| | | | MIN | MAX | MIN | MAX | MIN | MAX | |
| DR0 | $t_{su}(DAV-RDH)$ | Setup time, rfb_da[15:0] valid to rfb_rd high | 7.0 | | 9.0 | | | | ns |
| DR1 | $t_h(RDH-DAIV)$ | Hold time, rfb_rd high to rfb_da[15:0] invalid | 5.0 | | 5.0 | | | | ns |
| | $t_d(\text{Data sampled})$ | rfb_da[15:0] are sampled at the end off the access time | N ⁽²⁾ | | N ⁽²⁾ | | | | ns |

(1) Cannot boot in OPP1. If OPP1 is desired, boot in higher OPP then switch to OPP1.

(2) $N = (\text{AccessTime}) * (\text{TimeParaGranularity} + 1) * L4CLK$

Table 6-41. LCD Display Switching Characteristics in RFBI Mode

| PARAMETER | | OPP3 | | OPP2 | | OPP1 ⁽¹⁾ | | UNIT |
|-------------------------------------|---|-------------------|-----|-------------------|-----|---------------------|-----|------|
| | | MIN | MAX | MIN | MAX | MIN | MAX | |
| t _w (rfbi_wrH) | Pulse duration, rfbi_wr high | A ⁽²⁾ | | A ⁽²⁾ | | | | ns |
| t _w (rfbi_wrL) | Pulse duration, rfbi_wr low | B ⁽³⁾ | | B ⁽³⁾ | | | | ns |
| t _d (rfbi_a0-rfbi_wrL) | Delay time, rfbi_a0 transition to rfbi_wr low | C ⁽⁴⁾ | | C ⁽⁴⁾ | | | | ns |
| t _d (rfbi_wrH-rfbi_a0) | Delay time, rfbi_wr high to rfbi_a0 transition | D ⁽⁵⁾ | | D ⁽⁵⁾ | | | | ns |
| t _d (rfbi_csx-rfbi_wrL) | Delay time, rfbi_csx ⁽¹⁵⁾ low to rfbi_wr low | E ⁽⁶⁾ | | E ⁽⁶⁾ | | | | ns |
| t _d (rfbi_wrH-rfbi_csxH) | Delay time, rfbi_wr high to rfbi_csx ⁽¹⁵⁾ high | F ⁽⁷⁾ | | F ⁽⁷⁾ | | | | ns |
| t _d (dataV) | rfbi_da[15:0] valid | G ⁽⁸⁾ | | G ⁽⁸⁾ | | | | ns |
| t _d (rfbi_a0H-rfbi_rdL) | Delay time, rfbi_a0 high to rfbi_rd low | H ⁽⁹⁾ | | H ⁽⁹⁾ | | | | ns |
| t _d (rfbi_rdH-rfbi_a0) | Delay time, rfbi_rd high to rfbi_a0 transition | I ⁽¹⁰⁾ | | I ⁽¹⁰⁾ | | | | ns |
| t _w (rfbi_rdH) | Pulse duration, rfbi_rd high | J ⁽¹¹⁾ | | J ⁽¹¹⁾ | | | | ns |
| t _w (rfbi_rdL) | Pulse duration, rfbi_rd low | K ⁽¹²⁾ | | K ⁽¹²⁾ | | | | ns |
| t _d (rfbi_rdL-rfbi_csxL) | Delay time, rfbi_rd low to rfbi_csx ⁽¹⁵⁾ low | L ⁽¹³⁾ | | L ⁽¹³⁾ | | | | ns |
| t _d (rfbi_rdH-rfbi_csxH) | Delay time, rfbi_rd high to rfbi_csx ⁽¹⁵⁾ high | M ⁽¹⁴⁾ | | M ⁽¹⁴⁾ | | | | ns |
| t _R (rfbi_wr) | Rise time, rfbi_wr | | 10 | | 10 | | | ns |
| t _F (rfbi_wr) | Fall time, rfbi_wr | | 10 | | 10 | | | ns |
| t _R (rfbi_a0) | Rise time, rfbi_a0 | | 10 | | 10 | | | ns |
| t _F (rfbi_a0) | Fall time, rfbi_a0 | | 10 | | 10 | | | ns |
| t _R (rfbi_csx) | Rise time, rfbi_csx ⁽¹⁵⁾ | | 10 | | 10 | | | ns |
| t _F (rfbi_csx) | Fall time, rfbi_csx ⁽¹⁵⁾ | | 10 | | 10 | | | ns |
| t _R (rfbi_da[15:0]) | Rise time, rfbi_da[15:0] | | 10 | | 10 | | | ns |
| t _F (rfbi_da[15:0]) | Fall time, rfbi_da[15:0] | | 10 | | 10 | | | ns |
| t _R (rfbi_rd) | Rise time, rfbi_rd | | 10 | | 10 | | | ns |
| t _F (rfbi_rd) | Fall time, rfbi_rd | | 10 | | 10 | | | ns |

(1) Cannot boot in OPP1. If OPP1 is desired, boot in higher OPP then switch to OPP1.

(2) $A = (WECycleTime - WEOffTime) * (TimeParaGranularity + 1) * L4CLK$

(3) $B = (WEOffTime - WEOnTime) * (TimeParaGranularity + 1) * L4CLK$

(4) $C = WEOnTime * (TimeParaGranularity + 1) * L4CLK$

(5) $D = (WECycleTime + CSPulseWidth - WEOffTime) * (TimeParaGranularity + 1) * L4CLK$
if mode Write to Read or Read to Write is enabled

(6) $E = (WEOnTime - CSONTime) * (TimeParaGranularity + 1) * L4CLK$

(7) $F = (CSOffTime - WEOffTime) * (TimeParaGranularity + 1) * L4CLK$

(8) $G = (WECycleTime) * (TimeParaGranularity + 1) * L4CLK$

(9) $H = (REOnTime) * (TimeParaGranularity + 1) * L4CLK$

(10) $I = (RECycleTime + CSPulseWidth - REOffTime) * (TimeParaGranularity + 1) * L4CLK$
if mode Write to Read or Read to Write is enabled

(11) $J = (RECycleTime - REOffTime) * (TimeParaGranularity + 1) * L4CLK$

(12) $K = (REOffTime - REOnTime) * (TimeParaGranularity + 1) * L4CLK$

(13) $L = (REOnTime - CSONTime) * (TimeParaGranularity + 1) * L4CLK$

(14) $M = (CSOffTime - REOffTime) * (TimeParaGranularity + 1) * L4CLK$

(15) In rfbi_csx, x stands for 0 or 1.

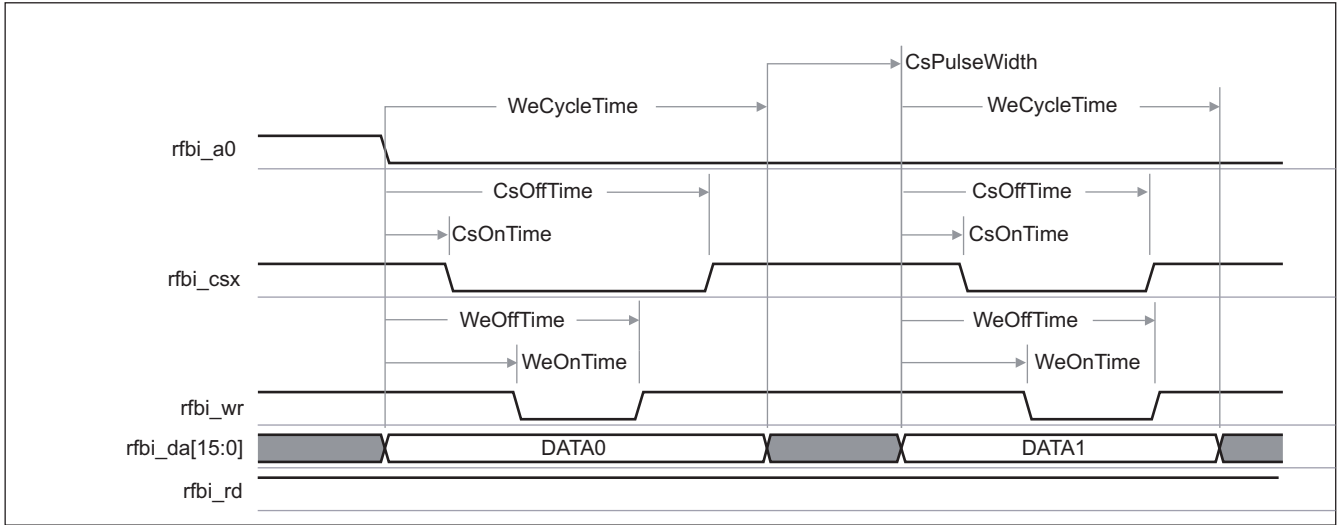

034-002

Figure 6-30. LCD Display in RFBI Mode – Command / Data Write Mode⁽¹⁾⁽²⁾

- (1) In rfb_i_csx, x is equal to 0 or 1.
- (2) For more information, see the DSS chapter in the *OMAP35x Technical Reference Manual (TRM)* [literature number [SPRUF98](#) .

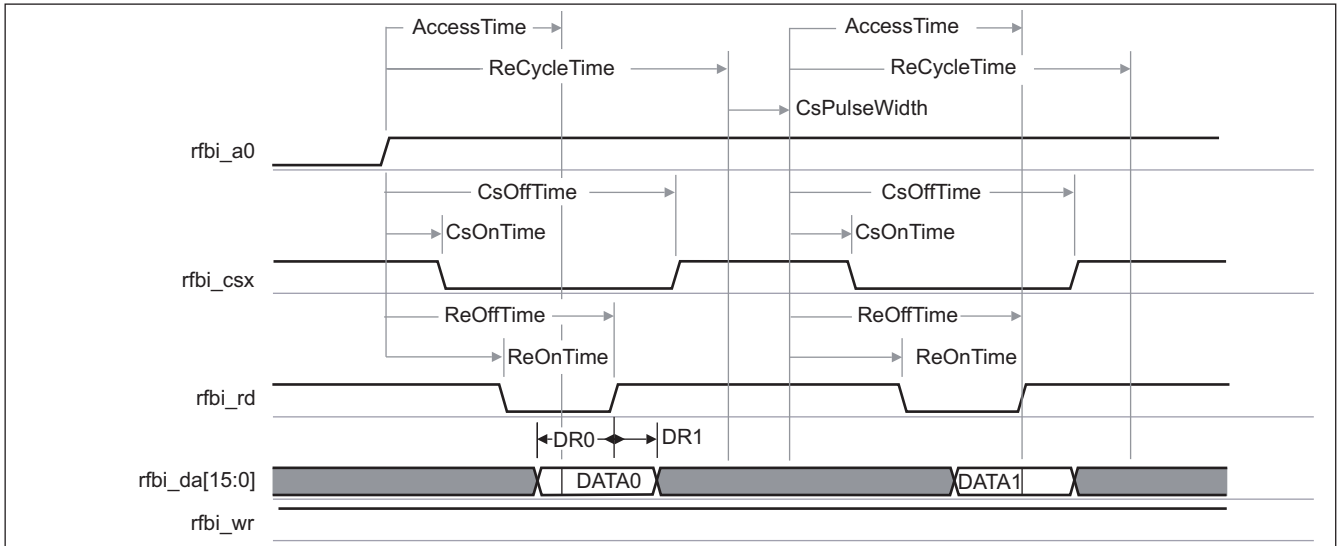

034-003

Figure 6-31. LCD Display in RFBI Mode – Data Read Mode⁽¹⁾⁽²⁾

- (1) In rfb_i_csx, x is equal to 0 or 1.
- (2) For more information, see the DSS chapter in the *OMAP35x Technical Reference Manual (TRM)* [literature number [SPRUF98](#) .

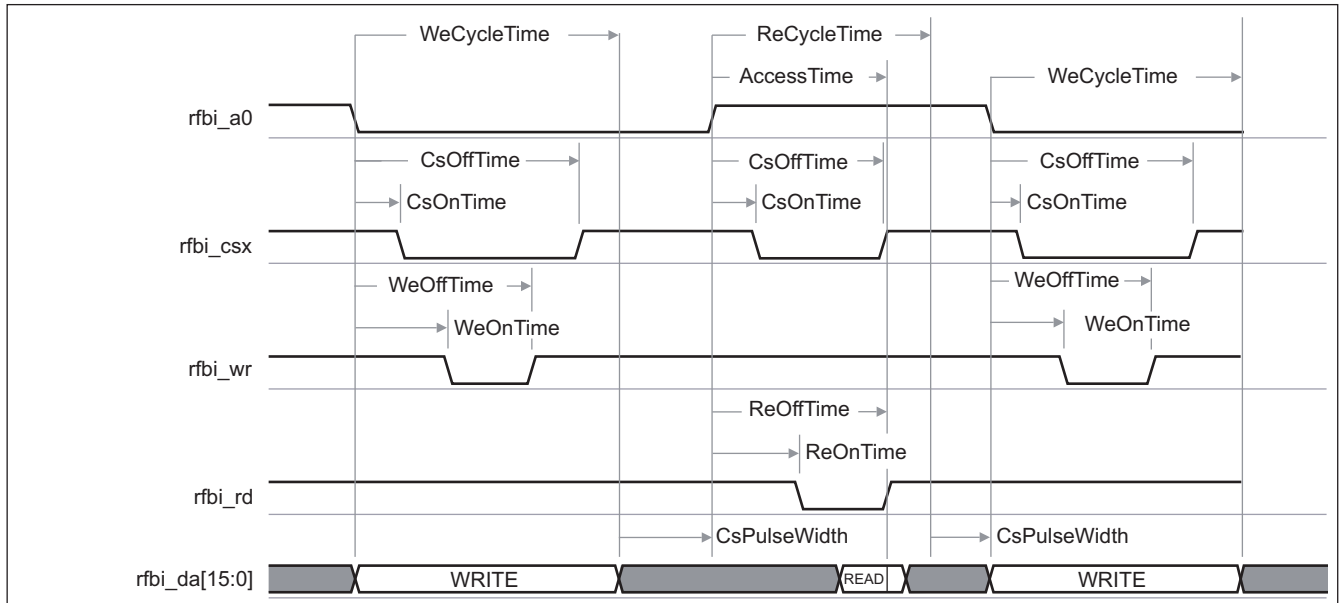

034-004

Figure 6-32. LCD Display in RFBI Mode – Command / Data Write-to-Read and Read-to-Write Timing Modes⁽¹⁾⁽²⁾

- (1) In `rfb_i_csx`, x is equal to 0 or 1.
- (2) For more information, see the DSS chapter in the *OMAP35x Technical Reference Manual (TRM)* [literature number [SPRUF98](#)].

6.6 Serial Communications Interfaces

6.6.1 Multichannel Buffered Serial Port (McBSP) Timing

There are five McBSP modules called McBSP1 through McBSP5. McBSP provides a full-duplex, direct serial interface between the OMAP3530/25 device and other devices in a system such as other application devices or codecs. It can accommodate a wide range of peripherals and clocked frame-oriented protocols (I2S, PCM, and TDM) due to its high level of versatility.

The McBSP1-5 modules may support two types of data transfer at the system level:

- The full-cycle mode, for which one clock period is used to transfer the data, generated on one edge and captured on the same edge (one clock period later).
- The half-cycle mode, for which one half clock period is used to transfer the data, generated on one edge and captured on the opposite edge (one half clock period later). Note that a new data is generated only every clock period, which secures the required hold time.

The interface clock (CLKX/CLKR) activation edge (data/frame sync capture and generation) has to be configured accordingly with the external peripheral (activation edge capability) and the type of data transfer required at the system level.

The OMAP3530/25 McBSP1-5 timing characteristics are described for both rising and falling activation edges. McBSP1 supports:

- 6-pin mode: dx and dr as data pins; clkx, clkr, fsx, and fsr as control pins.
- 4-pin mode: dx and dr as data pins; clkx and fsx pins as control pins. The clkx and fsx pins are internally looped back via software configuration, respectively, to the clkr and fsr internal signals for data receive.

McBSP2, 3, 4, and 5 support only the 4-pin mode.

The following sections describe the timing characteristics for applications in normal mode (that is, OMAP3530/25 McBSPx connected to one peripheral) and TDM applications in multipoint mode.

6.6.1.1 McBSP in Normal Mode

Table 6-42. McBSP Timing Conditions—Normal Mode

| TIMING CONDITION PARAMETER | | VALUE | UNIT |
|----------------------------|-------------------------|-------|------|
| Input Conditions | | | |
| t_R | Input signal rise time | 2 | ns |
| t_F | Input signal fall time | 2 | ns |
| Output Conditions | | | |
| C_{LOAD} | Output load capacitance | 10 | pF |

Table 6-43. McBSP Output Clock Pulse Duration

| NO. | PARAMETER | | OPP3 | | OPP2 | | UNIT |
|---------------------------|--------------|---|--------------------------------|-------|-------|-------|------|
| | | | MIN | MAX | MIN | MAX | |
| Inputs and Outputs | | | | | | | |
| McBSP1 | $t_{c(CLK)}$ | Cycle time, mcbbsp1_clkx / mcbbsp1_clkr (multiplexing mode 0) | 20.83 | | 41.67 | | ns |
| McBSP2 | $t_{c(CLK)}$ | Cycle time, mcbbsp2_clkx (multiplexing mode 0) | 20.83 | | 41.67 | | ns |
| McBSP3 | $t_{c(CLK)}$ | Cycle time, mcbbsp3_clkx | IO set 1 (multiplexing mode 0) | 31.25 | | 62.50 | ns |
| | | | IO set 2 (multiplexing mode 1) | 20.83 | | 41.67 | |
| | | | IO set 3 (multiplexing mode 2) | 20.83 | | 41.67 | |
| McBSP4 | $t_{c(CLK)}$ | Cycle time, mcbbsp4_clkx | IO set 1 (multiplexing mode 0) | 20.83 | | 41.67 | ns |
| | | | IO set 2 (multiplexing mode 2) | 31.25 | | 62.50 | |
| McBSP5 | $t_{c(CLK)}$ | Cycle time, mcbbsp5_clkx (multiplexing mode 1) | 31.25 | | 62.50 | | ns |

Table 6-43. McBSP Output Clock Pulse Duration (continued)

| NO. | PARAMETER | | OPP3 | | OPP2 | | UNIT |
|----------------|---------------|--|----------------------|------|----------------------|------|------|
| | | | MIN | MAX | MIN | MAX | |
| Outputs | | | | | | | |
| | $t_{w(CLKH)}$ | Typical pulse duration, mcbbsp1_clkr / mcbspx_clkx high ⁽²⁾ | 0.5*P ⁽¹⁾ | | 0.5*P ⁽¹⁾ | | ns |
| | $t_{w(CLKL)}$ | Typical pulse duration, mcbbsp1_clkr / mcbspx_clkx low ⁽²⁾ | 0.5*P ⁽¹⁾ | | 0.5*P ⁽¹⁾ | | ns |
| | $t_{dc(CLK)}$ | Duty cycle error, mcbbsp1_clkr / mcbspx_clkx ⁽²⁾ | -0.75 | 0.75 | -0.75 | 0.75 | ns |

- (1) P = mcbbsp1_clkr / mcbspx_clkx clock period.
- (2) In mcbspx, x identifies the McBSP number: 1, 2, 3, 4, or 5.

6.6.1.1.1 Receive Timing with Rising Edge as Activation Edge

Table 6-44 through Table 6-49 assume testing over the recommended operating conditions (see Figure 6-33 through Figure 6-34).

Table 6-44. McBSP1, 2, and 3 (Sets #2 and #3) Timing Requirements – Rising Edge and Receive Mode⁽¹⁾

| NO. | PARAMETER | | 1.15 V | | 1.0 V | | UNIT |
|-----|---------------------|--|--------|-----|-------|-----|------|
| | | | MIN | MAX | MIN | MAX | |
| B3 | $t_{su(DRV-CLKAE)}$ | Setup time, mcbspx_dr valid before mcbbsp1_clkr / mcbspx_clkx active edge | Master | 3.5 | | 7.7 | ns |
| | | | Slave | 3.7 | | 7.9 | ns |
| B4 | $t_h(CLKAE-DRV)$ | Hold time, mcbspx_dr valid after mcbbsp1_clkr / mcbspx_clkx active edge | Master | 1 | | 1 | ns |
| | | | Slave | 0.4 | | 0.4 | ns |
| B5 | $t_{su(FSV-CLKAE)}$ | Setup time, mcbbsp1_fsr / mcbspx_fsx valid before mcbbsp1_clkr / mcbspx_clkx active edge | | 3.7 | | 7.9 | ns |
| B6 | $t_h(CLKAE-FSV)$ | Hold time, mcbbsp1_fsr / mcbspx_fsx valid after mcbbsp1_clkr / mcbspx_clkx active edge | | 0.5 | | 0.5 | ns |

- (1) In mcbspx, x identifies the McBSP number: 1, 2, or 3. Note that for the McBSP3, these timings concern only Set #2 (multiplexing mode on UART pins) and Set #3 (multiplexing mode on McBSP1 pins).

Table 6-45. McBSP1, 2, and 3 (Sets #2 and #3) Switching Characteristics – Rising Edge and Receive Mode⁽¹⁾

| NO. | PARAMETER | | 1.15 V | | 1.0 V | | UNIT |
|-----|------------------|--|--------|------|-------|------|------|
| | | | MIN | MAX | MIN | MAX | |
| B2 | $t_d(CLKAE-FSV)$ | Delay time, mcbbsp1_clkr / mcbspx_clkx active edge to mcbbsp1_fsr / mcbspx_fsx valid | 0.7 | 14.8 | 0.7 | 29.6 | ns |

- (1) In mcbspx, x identifies the McBSP number: 1, 2, or 3. Note that for the McBSP3, these timings concern only Set #2 (multiplexing mode on UART pins) and Set #3 (multiplexing mode on McBSP1 pins).

Table 6-46. McBSP4 (Set #1) Timing Requirements – Rising Edge and Receive Mode⁽¹⁾

| NO. | PARAMETER | | 1.15 V | | 1.0 V | | UNIT |
|-----|-----------------------|--|--------|-----|-------|-----|------|
| | | | MIN | MAX | MIN | MAX | |
| B3 | $t_{su(DRV-CLKXAE)}$ | Setup time, mcbspx_dr valid before mcbspx_clkx active edge | Master | 2.7 | | 7.7 | ns |
| | | | Slave | 3.7 | | 7.9 | ns |
| B4 | $t_h(CLKXAE-DRV)$ | Hold time, mcbspx_dr valid after mcbspx_clkx active edge | Master | 1 | | 1 | ns |
| | | | Slave | 0.4 | | 0.4 | ns |
| B5 | $t_{su(FSXV-CLKXAE)}$ | Setup time mcbspx_fsx valid before mcbspx_clkx active edge | | 3.7 | | 7.9 | ns |
| B6 | $t_h(CLKXAE-FSXV)$ | Hold Time mcbspx_fsx valid after mcbspx_clkx active edge | | 0.5 | | 0.5 | ns |

- (1) In mcbspx, x identifies the McBSP number: 4. Note that for the McBSP4, these timings concern only Set #1: multiplexing mode by default. The McBSP4 is also multiplexed on GPMC pins (Set #2): the corresponding timings are specified in Table 6-48 and Table 6-49

Table 6-47. McBSP4 (Set #1) Switching Characteristics – Rising Edge and Receive Mode⁽¹⁾

| NO. | PARAMETER | | 1.15 V | | 1.0 V | | UNIT |
|-----|----------------------|---|--------|------|-------|------|------|
| | | | MIN | MAX | MIN | MAX | |
| B2 | $t_{d(CLKXAE-FSXV)}$ | Delay time, mcbsp _x _clkx active edge to mcbsp _x _fsx valid | 0.7 | 16.6 | 0.7 | 33.1 | ns |

(1) In mcbsp_x, x identifies the McBSP number: 4. Note that for the McBSP4, these timings concern only Set #1: multiplexing mode by default. The McBSP4 is also multiplexed on GPMC pins (Set #2): the corresponding timings are specified in Table 6-48 and Table 6-49

Table 6-48. McBSP3 (Set #1), 4 (Set #2), and 5 Timing Requirements – Rising Edge and Receive Mode⁽¹⁾

| NO. | PARAMETER | | 1.15 V | | 1.0 V | | UNIT |
|-----|-----------------------|---|--------|-----|-------|------|------|
| | | | MIN | MAX | MIN | MAX | |
| B3 | $t_{su(DRV-CLKXAE)}$ | Setup time, mcbsp _x _dr valid before mcbsp _x _clkx active edge | Master | 5.6 | | 12 | ns |
| | | | Slave | 5.8 | | 12.2 | ns |
| B4 | $t_h(CLKXAE-DRV)$ | Hold time, mcbsp _x _dr valid after mcbsp _x _clkx active edge | Master | 1 | | 1 | ns |
| | | | Slave | 0.4 | | 0.4 | ns |
| B5 | $t_{su(FSXV-CLKXAE)}$ | Setup time, mcbsp _x _fsx valid before mcbsp _x _clkx active edge | 5.8 | | 12.2 | | ns |
| B6 | $t_h(CLKXAE-FSXV)$ | Hold time, mcbsp _x _fsx valid after mcbsp _x _clkx active edge | 0.5 | | 0.5 | | ns |

(1) In mcbsp_x, x identifies the McBSP number: 3, 4, or 5. Note that for the McBSP3, these timings concern only Set #1: multiplexing mode by default. The McBSP3 is also multiplexed on UART pins (Set #2) and on McBSP1 pins (Set #3): the corresponding timings are specified in Table 6-46 and Table 6-47. For the McBSP4, these timings concern only Set #2 (multiplexing mode on GPMC pins).

Table 6-49. McBSP3 (Set #1), 4 (Set #2), and 5 Switching Requirements – Rising Edge and Receive Mode⁽¹⁾

| NO. | PARAMETER | | 1.15 V | | 1.0 V | | UNIT |
|-----|----------------------|---|--------|------|-------|------|------|
| | | | MIN | MAX | MIN | MAX | |
| B2 | $t_{d(CLKXAE-FSXV)}$ | Delay time, mcbsp _x _clkx active edge to mcbsp _x _fsx valid | 0.7 | 22.2 | 0.7 | 44.4 | ns |

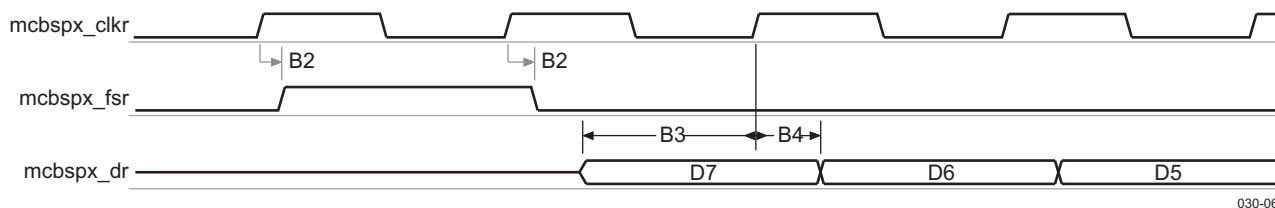

Figure 6-33. McBSP Rising Edge Receive Timing in Master Mode

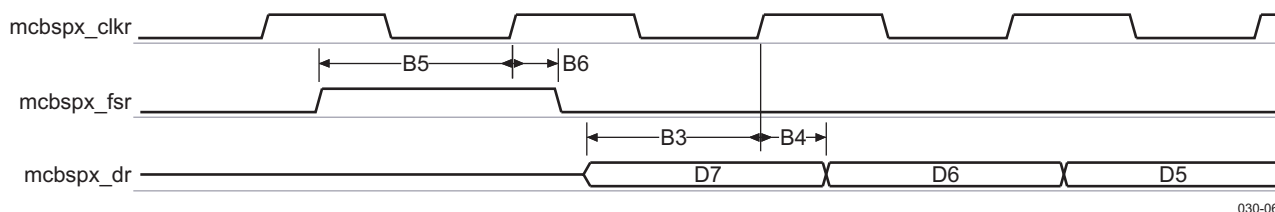

Figure 6-34. McBSP Rising Edge Receive Timing in Slave Mode

(1) In mcbsp_x, x identifies the McBSP number: 3, 4, or 5. Note that for the McBSP3, these timings concern only Set #1: multiplexing mode by default. The McBSP3 is also multiplexed on UART pins (Set #2) and on McBSP1 pins (Set #3): the corresponding timings are specified in Table 6-46 and Table 6-47. For the McBSP4, these timings concern only Set #2 (multiplexing mode on GPMC pins).

6.6.1.1.2 Transmit Timing with Rising Edge as Activation Edge

Table 6-50 through Table 6-55 assume testing over the recommended operating conditions (see Figure 6-35 and Figure 6-36).

Table 6-50. McBSP1, 2, and 3 (Sets #2 and #3) Timing Requirements – Rising Edge and Transmit Mode⁽¹⁾

| NO. | PARAMETER | | 1.15 V | | 1.0 V | | UNIT |
|-----|-----------------------|---|--------|-----|-------|-----|------|
| | | | MIN | MAX | MIN | MAX | |
| B5 | $t_{su}(FSXV-CLKXAE)$ | Setup time, mcbsp _x _fsx valid before mcbsp _x _clkx active edge | 3.7 | | 7.9 | | ns |
| B6 | $t_h(CLKXAE-FSXV)$ | Hold time, mcbsp _x _fsx valid after mcbsp _x _clkx active edge | 0.5 | | 0.5 | | ns |

(1) In mcbsp_x, x identifies the McBSP number: 1, 2, or 3. Note that for the McBSP3, these timings concern only Set #2 (multiplexing mode on UART pins) and Set #3 (multiplexing mode on McBSP1 pins).

Table 6-51. McBSP1, 2, and 3 (Sets #2 and #3) Switching Characteristics – Rising Edge and Transmit Mode⁽¹⁾

| NO. | PARAMETER | | 1.15 V | | 1.0 V | | UNIT | |
|-----|--------------------|---|--------|------|-------|------|------|----|
| | | | MIN | MAX | MIN | MAX | | |
| B2 | $t_d(CLKXAE-FSXV)$ | Delay time, mcbsp _x _clkx active edge to mcbsp _x _fsx valid | 0.7 | 14.8 | 0.7 | 29.6 | ns | |
| B8 | $t_d(CLKXAE-DXV)$ | Delay time, mcbsp _x _clkx active edge to mcbsp _x _dx valid | Master | 0.6 | 14.8 | 0.6 | 29.6 | ns |
| | | | Slave | 0.6 | 14.8 | 0.6 | 29.6 | ns |

(1) In mcbsp_x, x identifies the McBSP number: 1, 2, or 3. Note that for the McBSP3, these timings concern only Set #2 (multiplexing mode on UART pins) and Set #3 (multiplexing mode on McBSP1 pins).

Table 6-52. McBSP4 (Set #1) Timing Requirements – Rising Edge and Transmit Mode⁽¹⁾

| NO. | PARAMETER | | 1.15 V | | 1.0 V | | UNIT |
|-----|-----------------------|---|--------|-----|-------|-----|------|
| | | | MIN | MAX | MIN | MAX | |
| B5 | $t_{su}(FSXV-CLKXAE)$ | Setup time, mcbsp _x _fsx valid before mcbsp _x _clkx active edge | 3.7 | | 7.9 | | ns |
| B6 | $t_h(CLKXAE-FSXV)$ | Hold time, mcbsp _x _fsx valid after mcbsp _x _clkx active edge | 0.5 | | 0.5 | | ns |

(1) In mcbsp_x, x identifies the McBSP number: 4. Note that for the McBSP4, these timings concern only Set #1: multiplexing mode by default. The McBSP4 is also multiplexed on GPMC pins (Set #2): the corresponding timings are specified in Table 6-54.

Table 6-53. McBSP4 (Set #1) Switching Characteristics – Rising Edge and Transmit Mode⁽¹⁾

| NO. | PARAMETER | | 1.15 V | | 1.0 V | | UNIT | |
|-----|--------------------|---|--------|------|-------|------|------|----|
| | | | MIN | MAX | MIN | MAX | | |
| B2 | $t_d(CLKXAE-FSXV)$ | Delay time, mcbsp _x _clkx active edge to mcbsp _x _fsx valid | 0.7 | 16.6 | 0.7 | 33.1 | ns | |
| B8 | $t_d(CLKXAE-DXV)$ | Delay time, mcbsp _x _clkx active edge to mcbsp _x _dx valid | Master | 0.6 | 16.6 | 0.6 | 33.1 | ns |
| | | | Slave | 0.6 | 17.3 | 0.6 | 33.1 | ns |

(1) In mcbsp_x, x identifies the McBSP number: 4. Note that for the McBSP4, these timings concern only Set #1: multiplexing mode by default. The McBSP4 is also multiplexed on GPMC pins (Set #2): the corresponding timings are specified in Table 6-54.

Table 6-54. McBSP3 (Set #1), 4 (Set #2), and 5 Timing Requirements – Rising Edge and Transmit Mode⁽¹⁾

| NO. | PARAMETER | | 1.15 V | | 1.0 V | | UNIT |
|-----|-----------------------|---|--------|-----|-------|-----|------|
| | | | MIN | MAX | MIN | MAX | |
| B5 | $t_{su}(FSXV-CLKXAE)$ | Setup time, mcbsp _x _fsx valid before mcbsp _x _clkx active edge | 5.8 | | 12.2 | | ns |

(1) In mcbsp_x, x identifies the McBSP number: 4. Note that for the McBSP4, these timings concern only Set #1: multiplexing mode by default. The McBSP4 is also multiplexed on GPMC pins (Set #2): the corresponding timings are specified in Table 6-54.

Table 6-54. McBSP3 (Set #1), 4 (Set #2), and 5 Timing Requirements – Rising Edge and Transmit Mode (continued)

| NO. | PARAMETER | | 1.15 V | | 1.0 V | | UNIT |
|-----|----------------------|---|--------|-----|-------|-----|------|
| | | | MIN | MAX | MIN | MAX | |
| B6 | $t_{h(CLKXAE-FSXV)}$ | Hold time, mcbsp_x_fsx valid after mcbsp_x_clkx active edge | 0.5 | | 0.5 | | ns |

Table 6-55. McBSP 3 (Set #1), 4 (Set #2), and 5 Switching Requirements – Rising Edge and Transmit Mode⁽¹⁾

| NO. | PARAMETER | | 1.15 V | | 1.0 V | | UNIT | |
|-----|----------------------|---|--------|------|-------|------|------|----|
| | | | MIN | MAX | MIN | MAX | | |
| B2 | $t_{d(CLKXAE-FSXV)}$ | Delay time, mcbsp_x_clkx active edge to mcbsp_x_fsx valid | 0.7 | 22.2 | 0.7 | 44.4 | ns | |
| B8 | $t_{d(CLKXAE-DXV)}$ | Delay time, mcbsp_x_clkx active edge to mcbsp_x_dx valid | Master | 0.6 | 22.2 | 0.6 | 44.4 | ns |
| | | | Slave | 0.6 | 22.2 | 0.6 | 44.4 | ns |

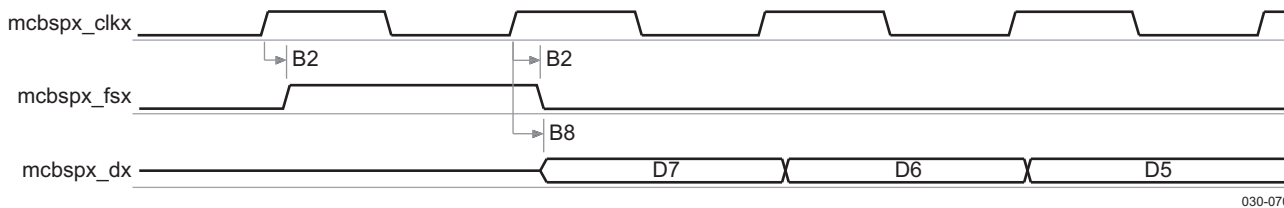

Figure 6-35. McBSP Rising Edge Transmit Timing in Master Mode

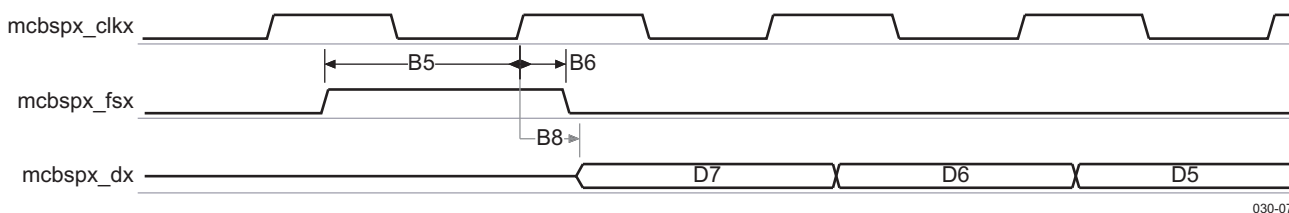

Figure 6-36. McBSP Rising Edge Transmit Timing in Slave Mode

(1) In mcbsp_x, x identifies the McBSP number: 3, 4 or 5. Note that for the McBSP3, these timings concern only Set #1: multiplexing mode by default. The McBSP3 is also multiplexed on UART pins (Set #2) and on McBSP1 pins (Set #3): the corresponding timings are specified in the table above. For the McBSP4, these timings concern only Set #2 (multiplexing mode on GPMC pins).

6.6.1.1.3 Receive Timing with Falling Edge as Activation Edge

Table 6-56 through Table 6-61 assume testing over the recommended operating conditions (see Figure 6-37 and Figure 6-38).

Table 6-56. McBSP1, 2, and 3 (Sets #2 and #3) Timing Requirements – Falling Edge and Receive Mode⁽¹⁾

| NO. | PARAMETER | | 1.15 V | | 1.0 V | | UNIT |
|-----|---------------------|--|--------|-----|-------|-----|------|
| | | | MIN | MAX | MIN | MAX | |
| B3 | $t_{su(DRV-CLKAE)}$ | Setup time, mcbsp_x_dr valid before mcbsp1_clkr / mcbsp_x_clkx active edge | Master | 3.5 | | 7.7 | ns |
| | | | Slave | 3.7 | | 7.9 | ns |
| B4 | $t_{h(CLKAE-DRV)}$ | Hold time, mcbsp_x_dr valid after mcbsp1_clkr / mcbsp_x_clkx active edge | Master | 1 | | 1 | ns |
| | | | Slave | 0.4 | | 0.4 | ns |
| B5 | $t_{su(FSV-CLKAE)}$ | Setup time, mcbsp1_fsr / mcbsp_x_fsx valid before mcbsp1_clkr / mcbsp_x_clkx active edge | 3.7 | | 7.9 | | ns |

(1) In mcbsp_x, x identifies the McBSP number: 1, 2, or 3. Note that for the McBSP3, these timings concern only Set #2 (multiplexing mode on UART pins) and Set #3 (multiplexing mode on McBSP1 pins).

Table 6-56. McBSP1, 2, and 3 (Sets #2 and #3) Timing Requirements – Falling Edge and Receive Mode (continued)

| NO. | PARAMETER | | 1.15 V | | 1.0 V | | UNIT |
|-----|--------------------|--|--------|-----|-------|-----|------|
| | | | MIN | MAX | MIN | MAX | |
| B6 | $t_{h(CLKAE-FSV)}$ | Hold time, mcbbsp1_fsr / mcbbsp_x_fsx valid after mcbbsp1_clkr / mcbbsp_x_clkx active edge | 0.5 | | 0.5 | | ns |

Table 6-57. McBSP1, 2, and 3 (Sets #2 and #3) Switching Characteristics – Falling Edge and Receive Mode⁽¹⁾

| NO. | PARAMETER | | 1.15 V | | 1.0 V | | UNIT |
|-----|------------------|--|--------|------|-------|------|------|
| | | | MIN | MAX | MIN | MAX | |
| B2 | $t_d(CLKAE-FSV)$ | Delay time, mcbbsp1_clkr / mcbbsp_x_clkx active edge to mcbbsp1_fsr / mcbbsp_x_fsx valid | 0.7 | 14.8 | 0.7 | 29.6 | ns |

(1) In mcbbsp_x, x identifies the McBSP number: 1, 2, or 3. Note that for the McBSP3, these timings concern only Set #2 (multiplexing mode on UART pins) and Set #3 (multiplexing mode on McBSP1 pins).

Table 6-58. McBSP4 (Set #1) Timing Requirements – Falling Edge and Receive Mode⁽¹⁾

| NO. | PARAMETER | | 1.15 V | | 1.0 V | | UNIT |
|-----|-----------------------|--|--------|-----|-------|-----|------|
| | | | MIN | MAX | MIN | MAX | |
| B3 | $t_{su(DRV-CLKXAE)}$ | Setup time, mcbbsp_x_dr valid before mcbbsp_x_clkx active edge | Master | 2.7 | | 7.7 | ns |
| | | | Slave | 3.7 | | 7.9 | ns |
| B4 | $t_h(CLKXAE-DRV)$ | Hold time, mcbbsp_x_dr valid after mcbbsp_x_clkx active edge | Master | 1 | | 1 | ns |
| | | | Slave | 0.4 | | 0.4 | ns |
| B5 | $t_{su(FSXV-CLKXAE)}$ | Setup time mcbbsp_x_fsx valid before mcbbsp_x_clkx active edge | 3.7 | | 7.9 | | ns |
| B6 | $t_h(CLKXAE-FSXV)$ | Hold time mcbbsp_x_fsx valid after mcbbsp_x_clkx active edge | 0.5 | | 0.5 | | ns |

(1) In mcbbsp_x, x identifies the McBSP number: 4. Note that for the McBSP4, these timings concern only Set #1: multiplexing mode by default. The McBSP4 is also multiplexed on GPMC pins (Set #2): the corresponding timings are specified in [Table 6-60](#)

Table 6-59. McBSP4 (Set #1) Switching Characteristics – Falling Edge and Receive Mode⁽¹⁾

| NO. | PARAMETER | | 1.15 V | | 1.0 V | | UNIT |
|-----|--------------------|---|--------|------|-------|------|------|
| | | | MIN | MAX | MIN | MAX | |
| B2 | $t_d(CLKXAE-FSXV)$ | Delay time, mcbbsp_x_clkx active edge to mcbbsp_x_fsx valid | 0.7 | 16.6 | 0.7 | 33.1 | ns |

(1) In mcbbsp_x, x identifies the McBSP number: 4. Note that for the McBSP4, these timings concern only Set #1: multiplexing mode by default. The McBSP4 is also multiplexed on GPMC pins (Set #2): the corresponding timings are specified in [Table 6-60](#)

Table 6-60. McBSP3 (Set #1), 4 (Set #2), and 5 Timing Requirements – Falling Edge and Receive Mode⁽¹⁾

| NO. | PARAMETER | | 1.15 V | | 1.0 V | | UNIT |
|-----|-----------------------|---|--------|-----|-------|------|------|
| | | | MIN | MAX | MIN | MAX | |
| B3 | $t_{su(DRV-CLKXAE)}$ | Setup time, mcbbsp_x_dr valid before mcbbsp_x_clkx active edge | Master | 5.6 | | 12 | ns |
| | | | Slave | 5.8 | | 12.2 | ns |
| B4 | $t_h(CLKXAE-DRV)$ | Hold time, mcbbsp_x_dr valid after mcbbsp_x_clkx active edge | Master | 1 | | 1 | ns |
| | | | Slave | 0.4 | | 0.4 | ns |
| B5 | $t_{su(FSXV-CLKXAE)}$ | Setup time, mcbbsp_x_fsx valid before mcbbsp_x_clkx active edge | 5.8 | | 12.2 | | ns |
| B6 | $t_h(CLKXAE-FSXV)$ | Hold time, mcbbsp_x_fsx valid after mcbbsp_x_clkx active edge | 0.5 | | 0.5 | | ns |

(1) In mcbbsp_x, x identifies the McBSP number: 3, 4, or 5. Note that for the McBSP3, these timings concern only Set #1: multiplexing mode by default. The McBSP3 is also multiplexed on UART pins (Set #2) and on McBSP1 pins (Set #3): the corresponding timings are specified in the table above. For the McBSP4, these timings concern only Set #2 (multiplexing mode on GPMC pins).

Table 6-61. McBSP3 (Set #1), 4 (Set #2), and 5 Switching Requirements – Falling Edge and Receive Mode⁽¹⁾

| NO. | PARAMETER | | 1.15 V | | 1.0 V | | UNIT |
|-----|----------------------|---|--------|------|-------|------|------|
| | | | MIN | MAX | MIN | MAX | |
| B2 | $t_{d(CLKXAE-FSXV)}$ | Delay time, mcbsp_x_clkx active edge to mcbsp_x_fsx valid | 0.7 | 22.2 | 0.7 | 44.4 | ns |

(1) In mcbsp_x, x identifies the McBSP number: 3, 4, or 5. Note that for the McBSP3, these timings concern only Set #1: multiplexing mode by default. The McBSP3 is also multiplexed on UART pins (Set #2) and on McBSP1 pins (Set #3): the corresponding timings are specified in the table above. For the McBSP4, these timings concern only Set #2 (multiplexing mode on GPMC pins).

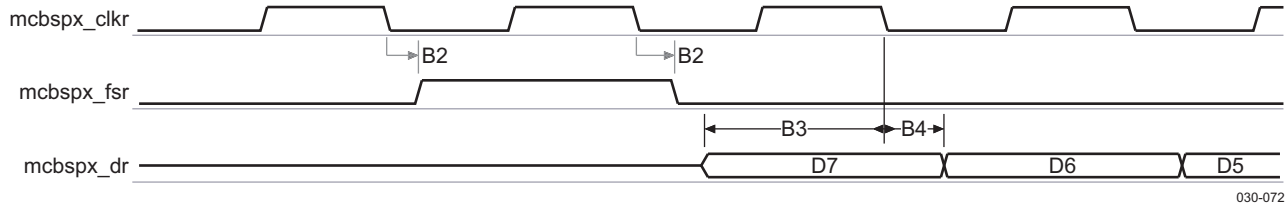

Figure 6-37. McBSP Falling Edge Receive Timing in Master Mode

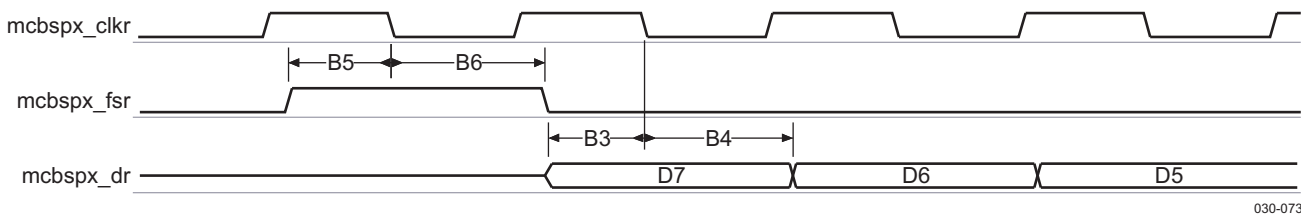

Figure 6-38. McBSP Falling Edge Receive Timing in Slave Mode

6.6.1.1.4 Transmit Timing with Falling Edge as Activation Edge

Table 6-62 through Table 6-67 assume testing over the recommended operating conditions (see Figure 6-39 and Figure 6-40).

Table 6-62. McBSP1, 2, and 3 (Sets #2 and #3) Timing Requirements – Falling Edge and Transmit Mode⁽¹⁾

| NO. | PARAMETER | | 1.15 V | | 1.0 V | | UNIT |
|-----|-----------------------|---|--------|-----|-------|-----|------|
| | | | MIN | MAX | MIN | MAX | |
| B5 | $t_{su(FSXV-CLKXAE)}$ | Setup time, mcbsp_x_fsx valid before mcbsp_x_clkx active edge | 3.7 | | 7.9 | | ns |
| B6 | $t_{h(CLKXAE-FSXV)}$ | Hold time, mcbsp_x_fsx valid after mcbsp_x_clkx active edge | 0.5 | | 0.5 | | ns |

(1) In mcbsp_x, x identifies the McBSP number: 1, 2, or 3. Note that for the McBSP3, these timings concern only Set #2 (multiplexing mode on UART pins) and Set #3 (multiplexing mode on McBSP1 pins).

Table 6-63. McBSP1, 2, and 3 (Sets #2 and #3) Switching Characteristics – Falling Edge and Transmit Mode⁽¹⁾

| NO. | PARAMETER | | 1.15 V | | 1.0 V | | UNIT |
|-----|----------------------|---|--------|------|-------|------|------|
| | | | MIN | MAX | MIN | MAX | |
| B2 | $t_{d(CLKXAE-FSXV)}$ | Delay time, mcbsp_x_clkx active edge to mcbsp_x_fsx valid | 0.7 | 14.8 | 0.7 | 29.6 | ns |
| B8 | $t_{d(CLKXAE-DXV)}$ | Master | 0.6 | 14.8 | 0.6 | 29.6 | ns |
| | | Slave | 0.6 | 14.8 | 0.6 | 29.6 | ns |

(1) In mcbsp_x, x identifies the McBSP number: 1, 2, or 3. Note that for the McBSP3, these timings concern only Set #2 (multiplexing mode on UART pins) and Set #3 (multiplexing mode on McBSP1 pins).

Table 6-64. McBSP4 (Set #1) Timing Requirements – Falling Edge and Transmit Mode⁽¹⁾

| NO. | PARAMETER | | 1.15 V | | 1.0 V | | UNIT |
|-----|-----------------------|---|--------|-----|-------|-----|------|
| | | | MIN | MAX | MIN | MAX | |
| B5 | $t_{su}(FSXV-CLKXAE)$ | Setup time, mcbsp_x_fsx valid before mcbsp_x_clkx active edge | 3.7 | | 7.9 | | ns |
| B6 | $t_h(CLKXAE-FSXV)$ | Hold time, mcbsp_x_fsx valid after mcbsp_x_clkx active edge | 0.5 | | 0.5 | | ns |

(1) In mcbsp_x, x identifies the McBSP number: 4. Note that for the McBSP4, these timings concern only Set #1: multiplexing mode by default. The McBSP4 is also multiplexed on GPMC pins (Set #2): the corresponding timings are specified in [Table 6-66](#).

Table 6-65. McBSP4 (Set #1) Switching Characteristics – Falling Edge and Transmit Mode⁽¹⁾

| NO. | PARAMETER | | 1.15 V | | 1.0 V | | UNIT | |
|-----|--------------------|---|--------|------|-------|------|------|----|
| | | | MIN | MAX | MIN | MAX | | |
| B2 | $t_d(CLKXAE-FSXV)$ | Delay time, mcbsp_x_clkx active edge to mcbsp_x_fsx valid | 0.7 | 16.6 | 0.7 | 33.1 | ns | |
| B8 | $t_d(CLKXAE-DXV)$ | Delay time, mcbsp_x_clkx active edge to mcbsp_x_dx valid | Master | 0.6 | 16.6 | 0.6 | 33.1 | ns |
| | | | Slave | 0.6 | 17.3 | 0.6 | 33.1 | ns |

(1) In mcbsp_x, x identifies the McBSP number: 4. Note that for the McBSP4, these timings concern only Set #1: multiplexing mode by default. The McBSP4 is also multiplexed on GPMC pins (Set #2): the corresponding timings are specified in [Table 6-66](#).

Table 6-66. McBSP3 (Set #1), 4 (Set #2), and 5 Timing Requirements – Falling Edge and Transmit Mode⁽¹⁾

| NO. | PARAMETER | | 1.15 V | | 1.0 V | | UNIT |
|-----|-----------------------|---|--------|-----|-------|-----|------|
| | | | MIN | MAX | MIN | MAX | |
| B5 | $t_{su}(FSXV-CLKXAE)$ | Setup time, mcbsp_x_fsx valid before mcbsp_x_clkx active edge | 5.8 | | 12.2 | | ns |
| B6 | $t_h(CLKXAE-FSXV)$ | Hold time, mcbsp_x_fsx valid after mcbsp_x_clkx active edge | 0.5 | | 0.5 | | ns |

(1) In mcbsp_x, x identifies the McBSP number: 3, 4, or 5. Note that for the McBSP3, these timings concern only Set #1: multiplexing mode by default. The McBSP3 is also multiplexed on UART pins (Set #2) and on McBSP1 pins (Set #3): the corresponding timings are specified in [Table 6-66](#). For the McBSP4, these timings concern only Set #2 (multiplexing mode on GPMC pins).

Table 6-67. McBSP3 (Set #1), 4 (Set #2), and 5 Switching Requirements – Falling Edge and Transmit Mode⁽¹⁾

| NO. | PARAMETER | | 1.15 V | | 1.0 V | | UNIT | |
|-----|--------------------|---|--------|------|-------|------|------|----|
| | | | MIN | MAX | MIN | MAX | | |
| B2 | $t_d(CLKXAE-FSXV)$ | Delay time, mcbsp_x_clkx active edge to mcbsp_x_fsx valid | 0.7 | 22.2 | 0.7 | 44.4 | ns | |
| B8 | $t_d(CLKXAE-DXV)$ | Delay time, mcbsp_x_clkx active edge to mcbsp_x_dx valid | Master | 0.6 | 22.2 | 0.6 | 44.4 | ns |
| | | | Slave | 0.6 | 22.2 | 0.6 | 44.4 | ns |

(1) In mcbsp_x, x identifies the McBSP number: 3, 4, or 5. Note that for the McBSP3, these timings concern only Set #1: multiplexing mode by default. The McBSP3 is also multiplexed on UART pins (Set #2) and on McBSP1 pins (Set #3): the corresponding timings are specified in [Table 6-66](#). For the McBSP4, these timings concern only Set #2 (multiplexing mode on GPMC pins).

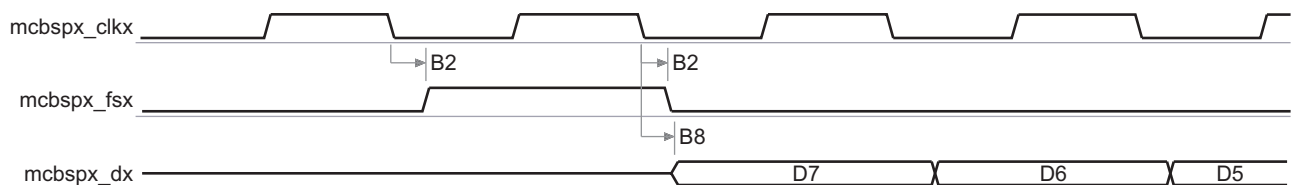

030-074

Figure 6-39. McBSP Falling Edge Transmit Timing in Master Mode

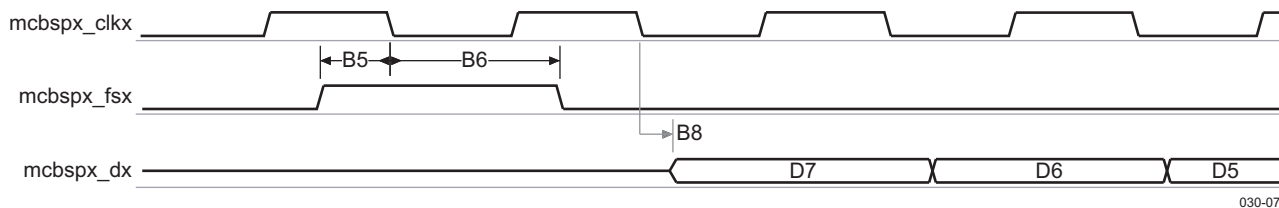

030-075

Figure 6-40. McBSP Falling Edge Transmit Timing in Slave Mode

6.6.1.2 McBSP in TDM—Multipoint Mode (McBSP3)

For TDM application in multipoint mode, OMAP3530/25 is considered as a slave. Table 6-69 and Table 6-70 assume testing over the operating conditions and electrical characteristic conditions described below.

Table 6-68. McBSP3 Timing Conditions—TDM in Multipoint Mode

| TIMING CONDITION PARAMETER | | VALUE | | UNIT |
|----------------------------|---------------------------|-------|-----|------|
| | | MIN | MAX | |
| Input Conditions | | | | |
| t _R | Input signal rising time | 1.0 | 8.5 | ns |
| t _F | Input signal falling time | 1.0 | 8.5 | ns |
| Output Conditions | | | | |
| C _{LOAD} | Output Load Capacitance | | 40 | pF |

Table 6-69. McBSP3 Timing Requirements—TDM in Multipoint Mode⁽¹⁾

| NO. | PARAMETER | | 1.15 V | | 1.0 V | | UNIT |
|-------------------|----------------------------|---|----------------------|------|----------------------|------|------|
| | | | MIN | MAX | MIN | MAX | |
| | t _{W(CLKH)} | Cycle Time, mcbssp3_clkx | 162.8 | | 162.8 | | ns |
| | t _{W(CLKH)} | Typical Pulse duration, mcbssp3_clkx high | 0.5*P ⁽²⁾ | | 0.5*P ⁽²⁾ | | ns |
| | t _{W(CLKL)} | Typical Pulse duration, mcbssp3_clkx low | 0.5*P ⁽²⁾ | | 0.5*P ⁽²⁾ | | ns |
| | t _{dc(CLK)} | Duty cycle error, mcbssp3_clkx | -8.14 | 8.14 | -8.14 | 8.14 | ns |
| B3 ⁽³⁾ | t _{su(DRV-CLKAE)} | Setup time, mcbssp3_dr valid before mcbssp3_clkx active edge | 9 | | 9 | | ns |
| B4 ⁽³⁾ | t _{h(CLKAE-DRV)} | Hold time, mcbssp3_dr valid after mcbssp3_clkx active edge | 2.4 | | 2.4 | | ns |
| B5 ⁽³⁾ | t _{su(FSV-CLKAE)} | Setup time, mcbssp3_fsx valid before mcbssp3_clkx active edge | 9 | | 9 | | ns |
| B6 ⁽³⁾ | t _{h(CLKAE-FSV)} | Hold time, mcbssp3_fsx valid after mcbssp3_clkx active edge | 2.4 | | 2.4 | | ns |

(1) For McBSP3, these timings concern only Set #3 (multiplexing mode in McBSP1 pins).

(2) P = mcbssp3_clkx period in ns

(3) See Section 6.6.1.1, McBSP in Normal Mode for corresponding figures.

Table 6-70. McBSP3 Switching Characteristics—TDM in Multipoint Mode⁽¹⁾

| NO. | PARAMETER | | 1.15 V | | 1.0 V | | UNIT |
|-------------------|----------------------------|--|--------|------|-------|------|------|
| | | | MIN | MAX | MIN | MAX | |
| B8 ⁽²⁾ | t _{d(CLKXAE-DXV)} | Delay time, mcbssp3_clkx active edge to mcbssp3_dx valid | 0.6 | 16.8 | 0.6 | 29.6 | ns |

(1) For McBSP3, these timings concern only Set #3 (multiplexing mode in McBSP1 pins).

(2) See Section 6.6.1.1, McBSP in Normal Mode for corresponding figures.

6.6.2 Multichannel Serial Port Interface (McSPI) Timing

The multichannel SPI is a master/slave synchronous serial bus. The McSPI1 module supports up to four peripherals and the others (McSPI2, McSPI3, and McSPI4) support up to two peripherals. The following timings are applicable to the different configurations of McSPI in master/slave mode for any McSPI and any channel (n).

6.6.2.1 McSPI in Slave Mode

Table 6-71 and Table 6-72 assume testing over the recommended operating conditions (see Figure 6-41).

Table 6-71. McSPI Interface Timing Requirements – Slave Mode⁽¹⁾⁽²⁾

| NO. | PARAMETER | | 1.15 V | | 1.0 V | | UNIT |
|-------|-----------------------|---|----------------------|----------------------|----------------------|----------------------|------|
| | | | MIN | MAX | MIN | MAX | |
| 1/SS0 | $1/t_{c(CLK)}$ | Frequency, mcspix_clk | | 24 | | 12 | MHz |
| | $t_{j(CLK)}$ | Cycle jitter ⁽³⁾ , mcspix_clk | -200 | 200 | -200 | 200 | ps |
| SS1 | $t_{w(CLK)}$ | Pulse duration, mcspix_clk high or low | $0.45 \cdot P^{(4)}$ | $0.55 \cdot P^{(4)}$ | $0.45 \cdot P^{(4)}$ | $0.55 \cdot P^{(4)}$ | ns |
| SS2 | $t_{su(SIMOV-CLKAE)}$ | Setup time, mcspix_simo valid before mcspix_clk active edge | 4.2 | | 9.5 | | ns |
| SS3 | $t_{h(SIMOV-CLKAE)}$ | Hold time, mcspix_simo valid after mcspix_clk active edge | 4.6 | | 9.9 | | ns |
| SS4 | $t_{su(CS0V-CLKFE)}$ | Setup time, mcspix_cs0 valid before mcspix_clk first edge | 13.8 | | 28.6 | | ns |
| SS5 | $t_{h(CS0I-CLKLE)}$ | Hold time, mcspix_cs0 invalid after mcspix_clk last edge | 13.8 | | 28.6 | | ns |

- (1) The input timing requirements are given by considering a rise time and a fall time of 4 ns.
- (2) In mcspix, x is equal to 1, 2, 3, or 4.
- (3) Maximum cycle jitter supported by mcspix_clk input clock.
- (4) P = mcspix_clk clock period

Table 6-72. McSPI Interface Switching Requirements⁽¹⁾⁽²⁾⁽³⁾⁽⁴⁾

| NO. | PARAMETER | | 1.15 V | | 1.0 V | | UNIT |
|-----|----------------------|---|--------|------|-------|------|------|
| | | | MIN | MAX | MIN | MAX | |
| SS6 | $t_{d(CLKAE-SOMIV)}$ | Delay time, mcspix_clk active edge to mcspix_somi shifted | 1.8 | 15.9 | 3.2 | 31.7 | ns |
| SS7 | $t_{d(CS0AE-SOMIV)}$ | Delay time, mcspix_cs0 active edge to mcspix_somi shifted | | 15.9 | | 31.7 | ns |

- (1) The capacitive load is equivalent to 20 pF.
- (2) In mcspix, x is equal to 1, 2, 3, or 4.
- (3) The polarity of mcspix_clk and the active edge (rising or falling) on which mcspix_simo is driven and mcspix_somi is latched is all software configurable.
- (4) This timing applies to all configurations regardless of mcspix_clk polarity and which clock edges are used to drive output data and capture input data.

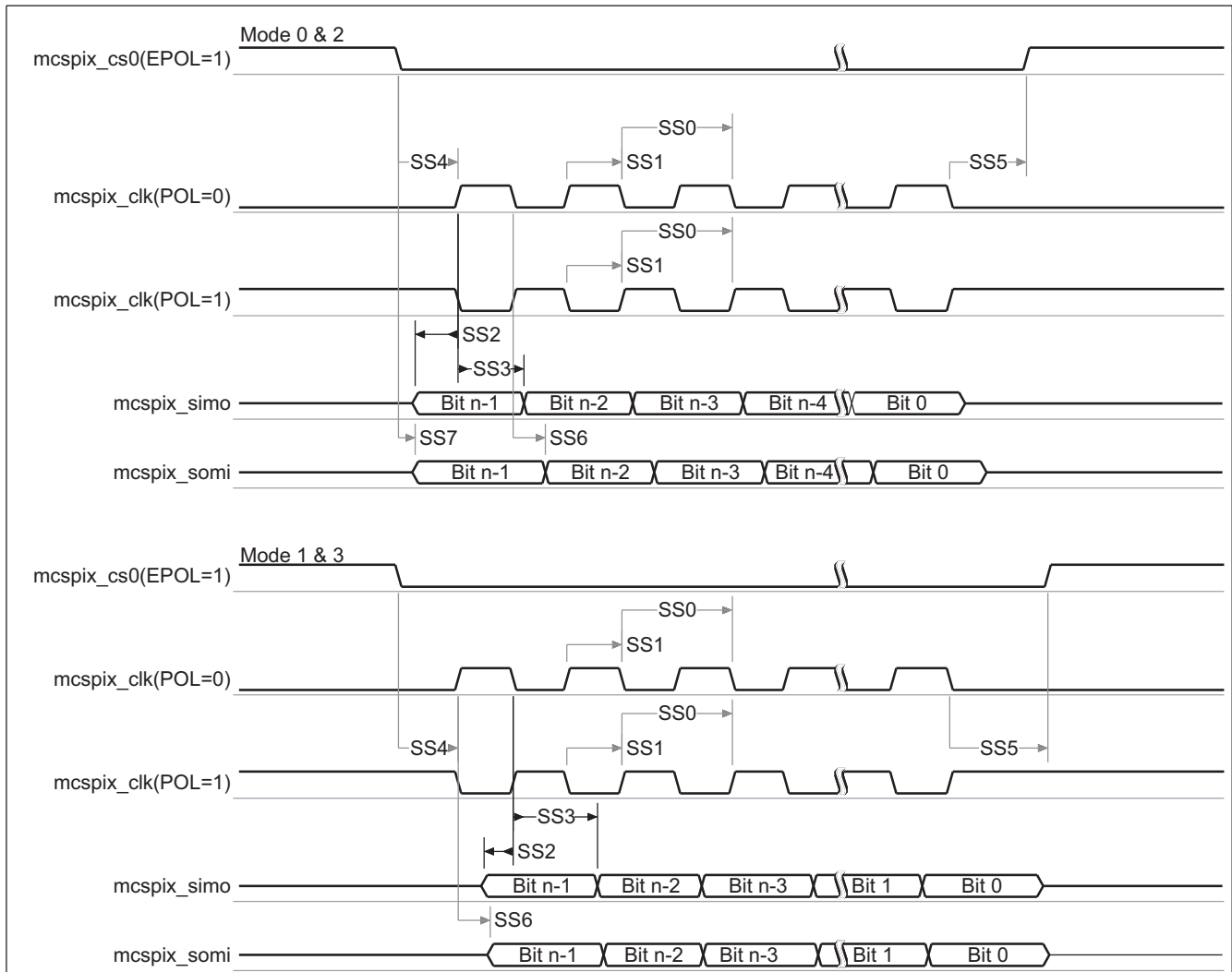

030-076

Figure 6-41. McSPI Interface – Transmit and Receive in Slave Mode⁽¹⁾⁽²⁾

- (1) The active clock edge (rising or falling) on which mcspi_somi is driven and mcspi_simo data is latched is software configurable with the bit MSP1_CHCONFx[0] = PHA and the bit MSP1_CHCONFx[1] = POL.
- (2) The polarity of mcspix_csi is software configurable with the bit MSP1_CHCONFx[6] = EPOL. In mcspix, x is equal to 1, 2, 3, or 4.

6.6.2.2 McSPI in Master Mode

Table 6-73 and Table 6-74 assume testing over the recommended operating conditions (see Figure 6-42).

Table 6-73. McSPI1, 2, and 4 Interface Timing Requirements – Master Mode⁽¹⁾⁽²⁾

| NO. | PARAMETER | | 1.15 V | | 1.0 V | | UNIT |
|-----|-----------------------|---|--------|-----|-------|-----|------|
| | | | MIN | MAX | MIN | MAX | |
| SM2 | $t_{su}(SOMIV-CLKAE)$ | Setup time, mcspix_somi valid before mcspix_clk active edge | 1.1 | | 1.5 | | ns |
| SM3 | $t_h(SOMIV-CLKAE)$ | Hold time, mcspix_somi valid after mcspix_clk active edge | 1.9 | | 2.8 | | ns |

- (1) The input timing requirements are given by considering a rise time and a fall time of 4 ns.
- (2) In mcspix, x is equal to 1, 2, or 4. In mcspix_csn, n is equal to 0, 1, 2, or 3 for x equal to 1, n is equal to 0 or 1 for x equal to 2 and 4.

Table 6-74. McSPI1, 2, and 4 Interface Switching Characteristics – Master Mode⁽¹⁾⁽²⁾⁽³⁾

| NO. | PARAMETER | | 1.15 V | | 1.0 V | | UNIT |
|-------|------------------------------|---|-----------------------|------------------------|-----------------------|------------------------|------|
| | | | MIN | MAX | MIN | MAX | |
| 1/SM0 | 1/t _c (CLK) | Frequency, mcspix_clk | | 48 | | 24 | MHz |
| | t _j (CLK) | Cycle jitter ⁽⁴⁾ , mcspix_clk | -200 | 200 | -200 | 200 | ps |
| SM1 | t _w (CLK) | Pulse duration, mcspix_clk high or low | 0.45*P ⁽⁵⁾ | 0.55*P ⁽⁵⁾ | 0.45*P ⁽⁵⁾ | 0.55*P ⁽⁵⁾ | ns |
| SM4 | t _d (CLKAE-SIMOV) | Delay time, mcspix_clk active edge to mcspix_simo shifted | -2.1 | 5 | -2.1 | 11.3 | ns |
| SM5 | t _d (CSnA-CLKFE) | Delay time, mcspix_csi active to mcspix_clk first edge | Modes 1 and 3 | A ⁽⁶⁾ – 3.1 | | A ⁽⁶⁾ – 4.4 | ns |
| | | | Modes 0 and 2 | B ⁽⁷⁾ – 3.1 | | B ⁽⁷⁾ – 4.4 | ns |
| SM6 | t _d (CLKLE-CSnI) | Delay time, mcspix_clk last edge to mcspix_csi inactive | Modes 1 and 3 | B ⁽⁷⁾ – 3.1 | | B ⁽⁷⁾ – 4.4 | ns |
| | | | Modes 0 and 2 | A ⁽⁶⁾ – 3.1 | | A ⁽⁶⁾ – 4.4 | ns |
| SM7 | t _d (CSnAE-SIMOV) | Delay time, mcspix_csi active edge to mcspix_simo shifted | | 5.0 | | 11.3 | ns |

- (1) Timings are given for a maximum load capacitance of 20 pF for spix_csn signals, 30 pF for spix_clk and spix_simo signals with x = 1 or 2, and 20 pF for spi4_clk and spi4_simo signals.
- (2) In mcspix, x is equal to 1, 2, or 4. In mcspix_csn, n is equal to 0, 1, 2, or 3 for x equal to 1, n is equal to 0 or 1 for x equal to 2 and 4.
- (3) The polarity of mcspix_clk and the active edge (rising or falling) on which mcspix_simo is driven and mcspix_somi is latched is all software configurable.
- (4) Maximum cycle jitter supported by mcspix_clk input clock.
- (5) P = mcspix_clk clock period
- (6) Case P = 20.8 ns, A = (TCS+0.5)*P (TCS is a bit field of MSPI_CHCONFx[26:25] register). Case P > 20.8 ns, A = TCS*P (TCS is a bitfield of MSPI_CHCONFx[26:25] register). For more information, see the McSPI chapter of the *OMAP35x Technical Reference Manual (TRM)* [literature number [SPRUJ98](#)].
- (7) B = TCS*P (TCS is a bit field of MSPI_CHCONFx[26:25] register). For more information, see the McSPI chapter of the *OMAP35x Technical Reference Manual (TRM)* [literature number [SPRUJ98](#)].

Table 6-75 and Table 6-76 assume testing over the recommended operating conditions (see Figure 6-42).

Table 6-75. McSPI 3 Interface Timing Requirements – Master Mode⁽¹⁾⁽²⁾

| NO. | PARAMETER | | 1.15 V | | 1.0 V | | UNIT |
|-----|-------------------------------|---|--------|-----|-------|-----|------|
| | | | MIN | MAX | MIN | MAX | |
| SM2 | t _{su} (SOMIV-CLKAE) | Setup time, mcspi3_somi valid before mcspi3_clk active edge | 1.5 | | 4.3 | | ns |
| SM3 | t _h (SOMIV-CLKAE) | Hold time, mcspi3_somi valid after mcspi3_clk active edge | 2.8 | | 5.9 | | ns |

- (1) The input timing requirements are given by considering a rise time and a fall time of 4 ns.
- (2) In mcspi3_csn, n is equal to 0 or 1. The polarity of mcspi3_clk and the active edge (rising or falling) on which mcspi3_simo is driven and mcspi3_somi is latched is all software configurable.

Table 6-76. McSPI3 Interface Switching Requirements – Master Mode⁽¹⁾⁽²⁾⁽³⁾

| NO. | PARAMETER | | 1.15 V | | 1.0 V | | UNIT |
|-------|------------------------|--|--------|-----|-------|-----|------|
| | | | MIN | MAX | MIN | MAX | |
| 1/SM0 | 1/t _c (CLK) | Frequency, mcspix_clk | | 24 | | 12 | MHz |
| | t _j (CLK) | Cycle jitter ⁽⁴⁾ , mcspix_clk | -200 | 200 | -200 | 200 | ps |

- (1) The capacitive load is equivalent to 20 pF.
- (2) In mcspi3_csn, n is equal to 0 or 1. The polarity of mcspi3_clk and the active edge (rising or falling) on which mcspi3_simo is driven and mcspi3_somi is latched is all software configurable.
- (3) This timing applies to all configurations regardless of McSPI3_CLK polarity and which clock edges are used to drive output data and capture input data.
- (4) Maximum cycle jitter supported by mcspix_clk input clock.

Table 6-76. McSPI3 Interface Switching Requirements – Master Mode (continued)

| NO. | PARAMETER | | 1.15 V | | 1.0 V | | UNIT |
|-----|-----------------------------|---|----------------------|----------------------|----------------------|----------------------|------|
| | | | MIN | MAX | MIN | MAX | |
| SM1 | $t_{w(\text{CLK})}$ | Pulse duration, mcspix_clk high or low | $0.45 \cdot P^{(5)}$ | $0.55 \cdot P^{(5)}$ | $0.45 \cdot P^{(5)}$ | $0.55 \cdot P^{(5)}$ | ns |
| SM4 | $t_{d(\text{CLKAE-SIMOV})}$ | Delay time, mcspix_clk active edge to mcspix_simo shifted | -2.1 | 11.3 | -5.3 | 23.6 | ns |
| SM5 | $t_{d(\text{CSnA-CLKFE})}$ | Delay time, mcspix_csi active to mcspix_clk first edge | Modes 1 and 3 | $-4.4 + A^{(6)}$ | | $-10.1 + A^{(6)}$ | ns |
| | | | Modes 0 and 2 | $-4.4 + B^{(7)}$ | | $-10.1 + B^{(7)}$ | ns |
| SM6 | $t_{d(\text{CLK-CSn})}$ | Delay time, mcspix_clk last edge to mcspix_csi inactive | Modes 1 and 3 | $B - 4.4^{(7)}$ | | $B - 10.1^{(7)}$ | ns |
| | | | Modes 0 and 2 | $A^{(6)} - 4.4$ | | $A^{(6)} - 10.1$ | ns |
| SM7 | $t_{d(\text{CSnAE-SIMOV})}$ | Delay time, mcspix_csi active edge to mcspix_simo shifted | | 11.3 | | 23.6 | ns |

(5) P = mcspix3_clk clock period

(6) Case $P = 20.8$ ns, $A = (TCS + 0.5) \cdot P$ (TCS is a bit field of MSPI_CHCONFx[26:25] register). Case $P > 20.8$ ns, $A = TCS \cdot P$ (TCS is a bit field of MSPI_CHCONFx[26:25] register). For more information, see the McSPI chapter of the *OMAP35x Technical Reference Manual (TRM)* [literature number [SPRUF98](#)].

(7) $B = TCS \cdot P$ (TCS is a bit field of MSPI_CHCONFx[26:25] register). For more information, see the McSPI chapter of the *OMAP35x Technical Reference Manual (TRM)* [literature number [SPRUF98](#)].

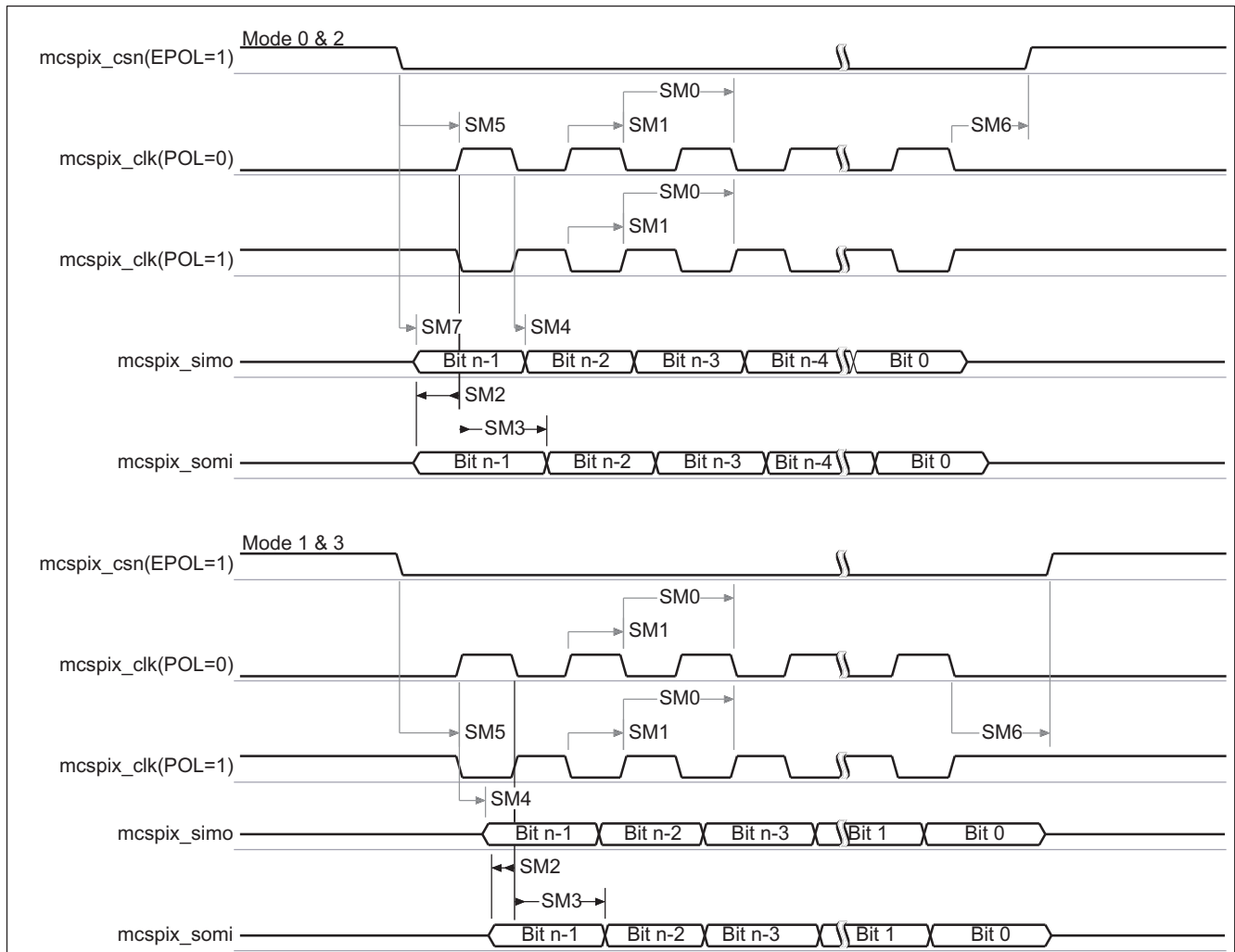

030-077

Figure 6-42. McSPI Interface – Transmit and Receive in Master Mode⁽¹⁾⁽²⁾⁽³⁾

- (1) The active clock edge (rising or falling) on which mcspx_simo is driven and mcspx_somi data is latched is software configurable with the bit MSPI_CHCONFx[0] = PHA and the bit MSPI_CHCONFx[1] = POL.
- (2) The polarity of mcspx_csi is software configurable with the bit MSPI_CHCONFx[6] = EPOL.
- (3) In mcspx, x is equal to 1. In mcspx_csn, n is equal to 0, 1, 2, or 3.

6.6.3 Multiport Full-Speed Universal Serial Bus (USB) Interface

The OMAP3530/25 processor provides three USB ports working in full- and low-speed data transactions (up to 12Mbit/s).

Connected to either a serial link controller (TLL modes) or a serial PHY (PHY interface modes) it supports:

- 6-pin (Tx: Dat/Se0 or Tx: Dp/Dm) unidirectional mode
- 4-pin bidirectional mode
- 3-pin bidirectional mode

6.6.3.1 Multiport Full-Speed Universal Serial Bus (USB) – Unidirectional Standard 6-pin Mode

Table 6-78 and Table 6-79 assume testing over the recommended operating conditions (see Figure 6-43).

Table 6-77. Low-/Full-Speed USB Timing Conditions – Unidirectional Standard 6-pin Mode

| TIMING CONDITION PARAMETER | | VALUE | UNIT |
|----------------------------|-------------------------|-------|------|
| Input Conditions | | | |
| t_R | Input signal rise time | 2.0 | ns |
| t_F | Input signal fall time | 2.0 | ns |
| Output Conditions | | | |
| C_{LOAD} | Output load capacitance | 15.0 | pF |

Table 6-78. Low-/Full-Speed USB Timing Requirements – Unidirectional Standard 6-pin Mode

| NO. | PARAMETER | | 1.15 V | | 1.0 V | | UNIT |
|------|-----------------|---|--------|------|-------|------|------|
| | | | MIN | MAX | MIN | MAX | |
| FSU1 | $t_d(V_p, V_m)$ | Time duration, mmx_rxdp and mmx_rxdm low together during transition | | 14.0 | | 14.0 | ns |
| FSU2 | $t_d(V_p, V_m)$ | Time duration, mmx_rxdp and mmx_rxdm high together during transition | | 8.0 | | 8.0 | ns |
| FSU3 | $t_d(RCVU0)$ | Time duration, mmx_rrxcv undefine during a single end 0 (mmx_rxdp and mmx_rxdm low together) | | 14.0 | | 14.0 | ns |
| FSU4 | $t_d(RCVU1)$ | Time duration, mmx_rrxcv undefine during a single end 1 (mmx_rxdp and mmx_rxdm high together) | | 8.0 | | 8.0 | ns |

Table 6-79. Low-/Full-Speed USB Switching Characteristics – Unidirectional Standard 6-pin Mode

| NO. | PARAMETER | | 1.15 V | | 1.0 V | | UNIT |
|------|-------------------|--|--------|------|-------|------|------|
| | | | MIN | MAX | MIN | MAX | |
| FSU5 | $t_d(TXENL-DATV)$ | Delay time, mmx_txen_n low to mmx_txdat valid | 81.8 | 84.8 | 81.8 | 84.8 | ns |
| FSU6 | $t_d(TXENL-SE0V)$ | Delay time, mmx_txen_n low to mmx_txse0 valid | 81.8 | 84.8 | 81.8 | 84.8 | ns |
| FSU7 | $t_s(DAT-SE0)$ | Skew between mmx_txdat and mmx_txse0 transition | | 1.5 | | 1.5 | ns |
| FSU8 | $t_d(DATI-TXENH)$ | Delay time, mmx_txdat invalid to mmx_txen_n high | 81.8 | | 81.8 | | ns |
| FSU9 | $t_d(SE0I-TXENH)$ | Delay time, mmx_txse0 invalid to mmx_txen_n high | 81.8 | | 81.8 | | ns |
| | $t_R(do)$ | Rise time, mmx_txen_n | | 4.0 | | 4.0 | ns |
| | $t_F(do)$ | Fall time, mmx_txen_n | | 4.0 | | 4.0 | ns |
| | $t_R(do)$ | Rise time, mmx_txdat | | 4.0 | | 4.0 | ns |
| | $t_F(do)$ | Fall time, mmx_txdat | | 4.0 | | 4.0 | ns |
| | $t_R(do)$ | Rise time, mmx_txse0 | | 4.0 | | 4.0 | ns |
| | $t_F(do)$ | Fall time, mmx_txse0 | | 4.0 | | 4.0 | ns |

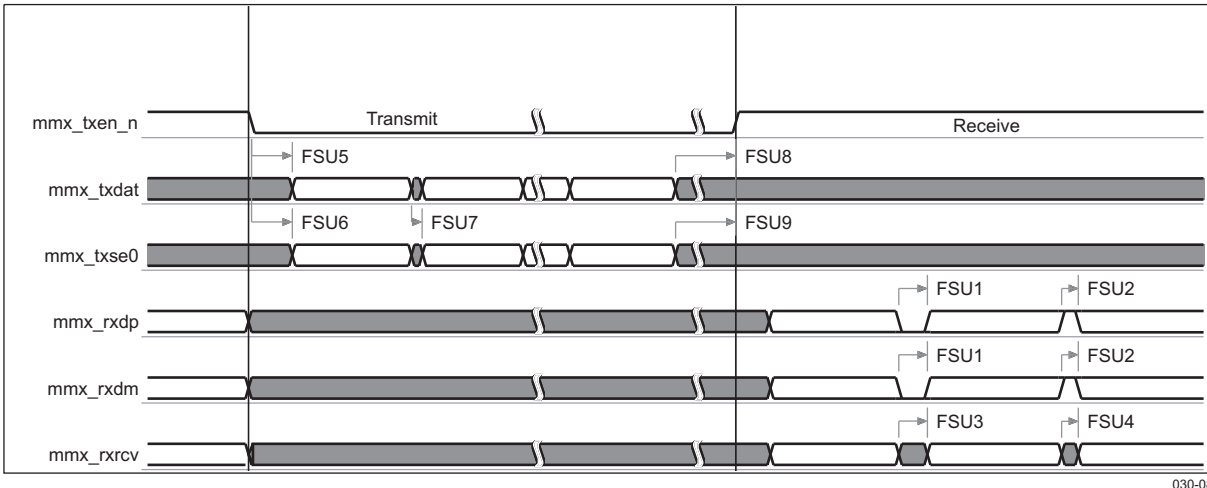

In mmx, x is equal to 0, 1, or 2.

Figure 6-43. Low-/Full-Speed USB – Unidirectional Standard 6-pin Mode

6.6.3.2 Multiport Full-Speed Universal Serial Bus (USB) – Bidirectional Standard 4-pin Mode

Table 6-81 and Table 6-82 assume testing over the recommended operating conditions (see Figure 6-44).

Table 6-80. Low-/Full-Speed USB Timing Conditions – Bidirectional Standard 4-pin Mode

| TIMING CONDITION PARAMETER | | VALUE | UNIT |
|----------------------------|-------------------------|-------|------|
| Input Conditions | | | |
| t_R | Input signal rise time | 2.0 | ns |
| t_F | Input signal fall time | 2.0 | ns |
| Output Conditions | | | |
| C_{LOAD} | Output load capacitance | 15.0 | pF |

Table 6-81. Low-/Full-Speed USB Timing Requirements – Bidirectional Standard 4-pin Mode

| NO. | PARAMETER | | 1.15 V | | 1.0 V | | UNIT |
|-------|------------------|--|--------|------|-------|------|------|
| | | | MIN | MAX | MIN | MAX | |
| FSU10 | $t_{d(DAT,SE0)}$ | Time duration, mmx_txdat and mmx_txse0 low together during transition | | 14.0 | | 14.0 | ns |
| FSU11 | $t_{d(DAT,SE0)}$ | Time duration, mmx_txdat and mmx_txse0 high together during transition | | 8.0 | | 8.0 | ns |
| FSU12 | $t_{d(RCVU0)}$ | Time duration, mmx_rxcv undefine during a single end 0 (mmx_txdat and mmx_txse0 low together) | | 14.0 | | 14.0 | ns |
| FSU13 | $t_{d(RCVU1)}$ | Time duration, mmx_rxcv undefine during a single end 1 (mmx_txdat and mmx_txse0 high together) | | 8.0 | | 8.0 | ns |

Table 6-82. Low-/Full-Speed USB Switching Characteristics – Bidirectional Standard 4-pin Mode

| NO. | PARAMETER | | 1.15 V | | 1.0 V | | UNIT |
|-------|---------------------|--|--------|------|-------|------|------|
| | | | MIN | MAX | MIN | MAX | |
| FSU14 | $t_{d(TXENL-DATV)}$ | Delay time, mmx_txen_n low to mmx_txdat valid | 81.8 | 84.8 | 81.8 | 84.8 | ns |
| FSU15 | $t_{d(TXENL-SE0V)}$ | Delay time, mmx_txen_n low to mmx_txse0 valid | 81.8 | 84.8 | 81.8 | 84.8 | ns |
| FSU16 | $t_{s(DAT-SE0)}$ | Skew between mmx_txdat and mmx_txse0 transition | | 1.5 | | 1.5 | ns |
| FSU17 | $t_{d(DATV-TXENH)}$ | Delay time, mmx_txdat invalid before mmx_txen_n high | 81.8 | | 81.8 | | ns |

Table 6-82. Low-/Full-Speed USB Switching Characteristics – Bidirectional Standard 4-pin Mode (continued)

| NO. | PARAMETER | | 1.15 V | | 1.0 V | | UNIT |
|-------|---------------------|--|--------|-----|-------|-----|------|
| | | | MIN | MAX | MIN | MAX | |
| FSU18 | $t_{d(SE0V-TXENH)}$ | Delay time, mmx_txse0 invalid before mmx_txen_n high | 81.8 | | 81.8 | | ns |
| | $t_{R(txen)}$ | Rise time, mmx_txen_n | | 4.0 | | 4.0 | ns |
| | $t_{F(txen)}$ | Fall time, mmx_txen_n | | 4.0 | | 4.0 | ns |
| | $t_{R(dat)}$ | Rise time, mmx_txdat | | 4.0 | | 4.0 | ns |
| | $t_{F(dat)}$ | Fall time, mmx_txdat | | 4.0 | | 4.0 | ns |
| | $t_{R(se0)}$ | Rise time, mmx_txse0 | | 4.0 | | 4.0 | ns |
| | $t_{F(se0)}$ | Fall time, mmx_txse0 | | 4.0 | | 4.0 | ns |

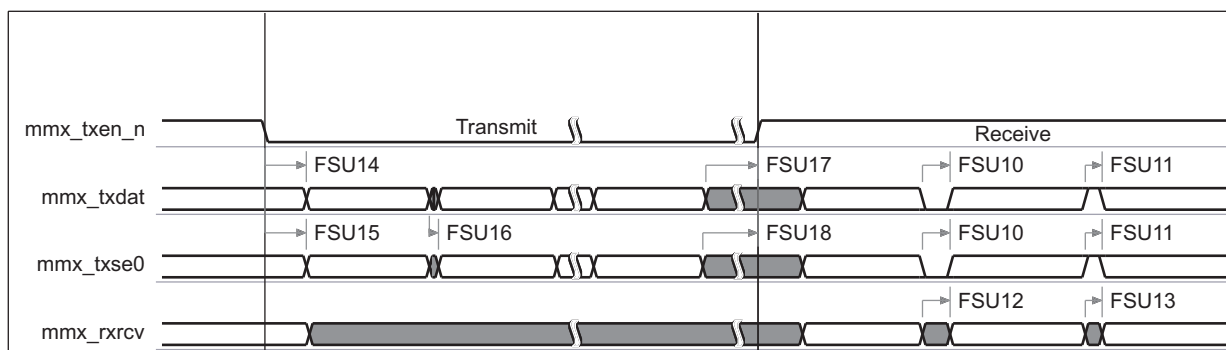

030-081

In mmx, x is equal to 0, 1, or 2.

Figure 6-44. Low-/Full-Speed USB – Bidirectional Standard 4-pin Mode

6.6.3.3 Multiport Full-Speed Universal Serial Bus (USB) – Bidirectional Standard 3-pin Mode

Table 6-84 and Table 6-85 assume testing over the recommended operating conditions below (see Figure 6-45).

Table 6-83. Low-/Full-Speed USB Timing Conditions – Bidirectional Standard 3-pin Mode

| TIMING CONDITION PARAMETER | | VALUE | UNIT |
|----------------------------|-------------------------|-------|------|
| Input Conditions | | | |
| t_R | Input signal rise time | 2.0 | ns |
| t_F | Input signal fall time | 2.0 | ns |
| Output Conditions | | | |
| C_{LOAD} | Output load capacitance | 15.0 | pF |

Table 6-84. Low-/Full-Speed USB Timing Requirements – Bidirectional Standard 3-pin Mode

| NO. | PARAMETER | | 1.15 V | | 1.0 V | | UNIT |
|-------|------------------|--|--------|------|-------|------|------|
| | | | MIN | MAX | MIN | MAX | |
| FSU19 | $t_{d(DAT,SE0)}$ | Time duration, mmx_txdat and mmx_txse0 low together during transition | | 14.0 | | 14.0 | ns |
| FSU20 | $t_{d(DAT,SE0)}$ | Time duration, mmx_txdat and mmx_txse0 high together during transition | | 8.0 | | 8.0 | ns |

Table 6-85. Low-/Full-Speed USB Switching Characteristics – Bidirectional Standard 3-pin Mode

| NO. | PARAMETER | | 1.15 V | | 1.0 V | | UNIT |
|-------|---------------------|--|--------|------|-------|------|------|
| | | | MIN | MAX | MIN | MAX | |
| FSU21 | $t_{d(TXENL-DATV)}$ | Delay time, mmx_txen_n low to mmx_txdat valid | 81.8 | 84.8 | 81.8 | 84.8 | ns |
| FSU22 | $t_{d(TXENL-SE0V)}$ | Delay time, mmx_txen_n low to mmx_txse0 valid | 81.8 | 84.8 | 81.8 | 84.8 | ns |
| FSU23 | $t_{s(DAT-SE0)}$ | Skew between mmx_txdat and mmx_txse0 transition | | 1.5 | | 1.5 | ns |
| FSU24 | $t_{d(DATI-TXENH)}$ | Delay time, mmx_txdat invalid to mmx_txen_n high | 81.8 | | 81.8 | | ns |
| FSU25 | $t_{d(SE0I-TXENH)}$ | Delay time, mmx_txse0 invalid to mmx_txen_n high | 81.8 | | 81.8 | | ns |
| | $t_{R(do)}$ | Rise time, mmx_txen_n | | 4.0 | | 4.0 | ns |
| | $t_{F(do)}$ | Fall time, mmx_txen_n | | 4.0 | | 4.0 | ns |
| | $t_{R(do)}$ | Rise time, mmx_txdat | | 4.0 | | 4.0 | ns |
| | $t_{F(do)}$ | Fall time, mmx_txdat | | 4.0 | | 4.0 | ns |
| | $t_{R(do)}$ | Rise time, mmx_txse0 | | 4.0 | | 4.0 | ns |
| | $t_{F(do)}$ | Fall time, mmx_txse0 | | 4.0 | | 4.0 | ns |

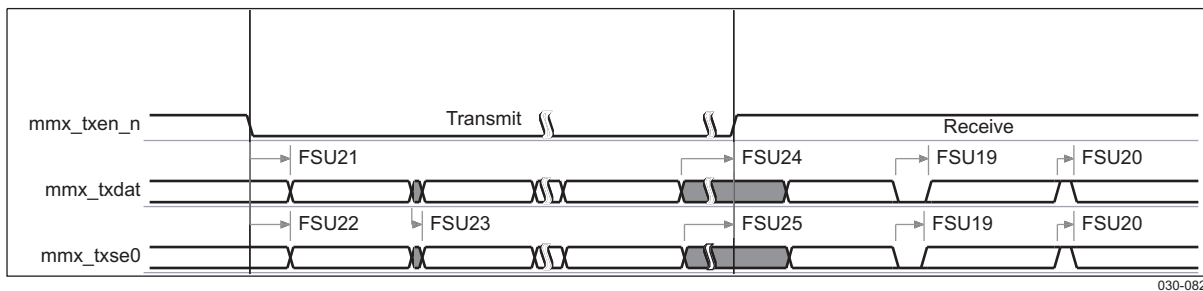

In mmx, x is equal to 0, 1, or 2.

Figure 6-45. Low-/Full-Speed USB – Bidirectional Standard 3-pin Mode

6.6.3.4 Multiport Full-Speed Universal Serial Bus (USB) – Unidirectional TLL 6-pin Mode

Table 6-87 and Table 6-88 assume testing over the recommended operating conditions (see Figure 6-46).

Table 6-86. Low-/Full-Speed USB Timing Conditions – Unidirectional TLL 6-pin Mode

| TIMING CONDITION PARAMETER | | VALUE | UNIT |
|----------------------------|-------------------------|-------|------|
| Input Conditions | | | |
| t_R | Input signal rise time | 2 | ns |
| t_F | Input signal fall time | 2 | ns |
| Output Conditions | | | |
| C_{LOAD} | Output load capacitance | 15 | pF |

Table 6-87. Low-/Full-Speed USB Timing Requirements – Unidirectional TLL 6-pin Mode

| NO. | PARAMETER | | 1.15 V | | 1.0 V | | UNIT |
|-------|------------------|--|--------|-----|-------|-----|------|
| | | | MIN | MAX | MIN | MAX | |
| FSUT1 | $t_{d(SE0,DAT)}$ | Time duration, mmx_txse0 and mmx_txdat low together during transition | | 14 | | 14 | ns |
| FSUT2 | $t_{d(SE0,DAT)}$ | Time duration, mmx_txse0 and mmx_txdat high together during transition | | 8 | | 8 | ns |

Table 6-88. Low-/Full-Speed USB Switching Characteristics – Unidirectional TLL 6-pin Mode

| NO. | PARAMETER | | 1.15 V | | 1.0 V | | UNIT |
|-------|--------------------|--|--------|------|-------|------|------|
| | | | MIN | MAX | MIN | MAX | |
| FSUT3 | $t_{d(TXENH-DPV)}$ | Delay time, mmx_txen_n high to mmx_rxdp valid | 81.8 | 84.8 | 81.8 | 84.8 | ns |
| FSUT4 | $t_{d(TXENH-DMV)}$ | Delay time, mmx_txen_n high to mmx_rxdm valid | 81.8 | 84.8 | 81.8 | 84.8 | ns |
| FSUT5 | $t_{d(DPI-TXENL)}$ | Delay time, mmx_rxdp invalid mmx_txen_n low | 81.8 | | 81.8 | | ns |
| FSUT6 | $t_{d(DMI-TXENL)}$ | Delay time, mmx_rxdm invalid mmx_txen_n low | 81.8 | | 81.8 | | ns |
| FSUT7 | $t_{s(DP-DM)}$ | Skew between mmx_rxdp and mmx_rxdm transition | | 1.5 | | 1.5 | ns |
| FSUT8 | $t_{s(DP,DM-RCV)}$ | Skew between mmx_rxdp, mmx_rxdm, and mmx_rxcv transition | | 1.5 | | 1.5 | ns |
| | $t_{R(rxrcv)}$ | Rise time, mmx_rxcv | | 4 | | 4 | ns |
| | $t_{F(rxrcv)}$ | Fall time, mmx_rxcv | | 4 | | 4 | ns |
| | $t_{R(dp)}$ | Rise time, mmx_rxdp | | 4 | | 4 | ns |
| | $t_{F(dp)}$ | Fall time, mmx_rxdp | | 4 | | 4 | ns |
| | $t_{R(dm)}$ | Rise time, mmx_rxdm | | 4 | | 4 | ns |
| | $t_{F(dm)}$ | Fall time, mmx_rxdm | | 4 | | 4 | ns |

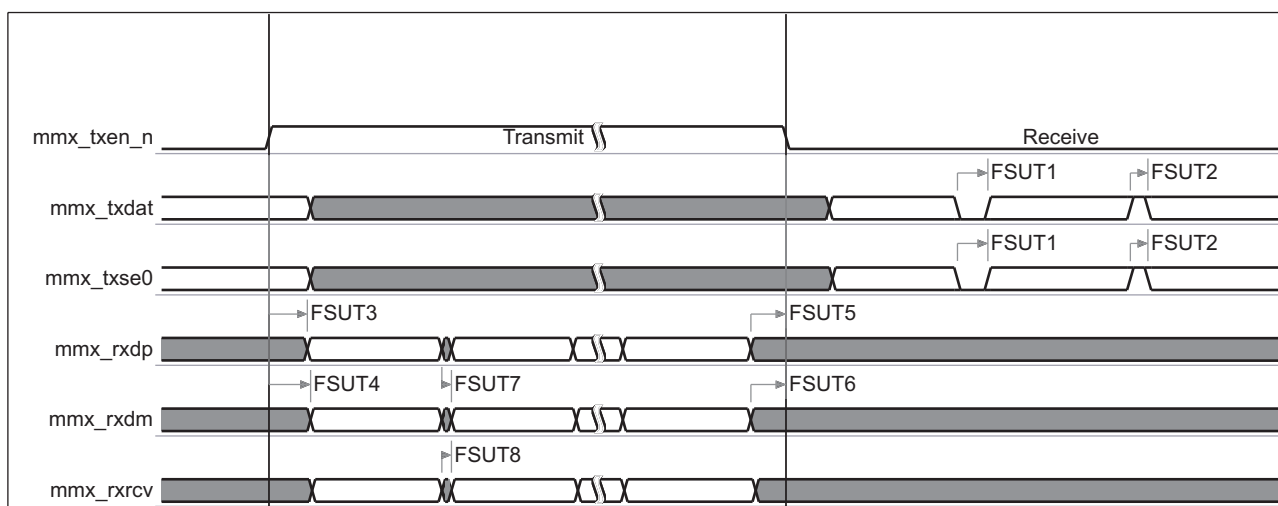

030-083

In mmx, x is equal to 0, 1, or 2.

Figure 6-46. Low-/Full-Speed USB – Unidirectional TLL 6-pin Mode

6.6.3.5 Multiport Full-Speed Universal Serial Bus (USB) – Bidirectional TLL 4-pin Mode

Table 6-90 and Table 6-91 assume testing over the recommended operating conditions (see Figure 6-47).

Table 6-89. Low-/Full-Speed USB Timing Conditions – Bidirectional TLL 4-pin Mode

| TIMING CONDITION PARAMETER | | VALUE | UNIT |
|----------------------------|-------------------------|-------|------|
| Input Conditions | | | |
| t_R | Input signal rise time | 2 | ns |
| t_F | Input signal fall time | 2 | ns |
| Output Conditions | | | |
| C_{LOAD} | Output load capacitance | 15 | pF |

Table 6-90. Low-/Full-Speed USB Timing Requirements – Bidirectional TLL 4-pin Mode

| NO. | PARAMETER | | 1.15 V | | 1.0 V | | UNIT |
|--------|------------------|---|--------|-----|-------|-----|------|
| | | | MIN | MAX | MIN | MAX | |
| FSUT9 | $t_{d(DAT,SE0)}$ | Time duration, mmx_txdat and mmx_txse0 low together during transition | | 14 | | 14 | ns |
| FSUT10 | $t_{d(DAT,SE0)}$ | Time duration, mmx_tsdats and mmx_txse0 high together during transition | | 8 | | 8 | ns |

Table 6-91. Low-/Full-Speed USB Switching Characteristics – Bidirectional TLL 4-pin Mode

| NO. | PARAMETER | | 1.15 V | | 1.0 V | | UNIT |
|--------|---------------------|--|--------|------|-------|------|------|
| | | | MIN | MAX | MIN | MAX | |
| FSUT11 | $t_{d(TXENL-DATV)}$ | Delay time, mmx_txen_n active to mmx_txdat valid | 81.8 | 84.8 | 81.8 | 84.8 | ns |
| FSUT12 | $t_{d(TXENL-SE0V)}$ | Delay time, mmx_txen_n active to mmx_txse0 valid | 81.8 | 84.8 | 81.8 | 84.8 | ns |
| FSUT13 | $t_{s(DAT-SE0)}$ | Skew between mmx_txdat and mmx_txse0 transition | | 1.5 | | 1.5 | ns |
| FSUT14 | $t_{s(DP,DM-RCV)}$ | Skew between mmx_rxdp, mmx_rxdm, and mmx_rxcv transition | | 1.5 | | 1.5 | ns |
| FSUT15 | $t_{d(DATI-TXENL)}$ | Delay time, mmx_txse0 invalid to mmx_txen_n Low | 81.8 | | 81.8 | | ns |
| FSUT16 | $t_{d(SE0I-TXENL)}$ | Delay time, mmx_txdat invalid to mmx_txen_n Low | 81.8 | | 81.8 | | ns |
| | $t_{R(rcv)}$ | Rise time, mmx_rxcv | | 4 | | 4 | ns |
| | $t_{F(rcv)}$ | Fall time, mmx_rxcv | | 4 | | 4 | ns |
| | $t_{R(dat)}$ | Rise time, mmx_txdat | | 4 | | 4 | ns |
| | $t_{F(dat)}$ | Fall time, mmx_txdat | | 4 | | 4 | ns |
| | $t_{R(se0)}$ | Rise time, mmx_txse0 | | 4 | | 4 | ns |
| | $t_{F(se0)}$ | Fall time, mmx_txse0 | | 4 | | 4 | ns |

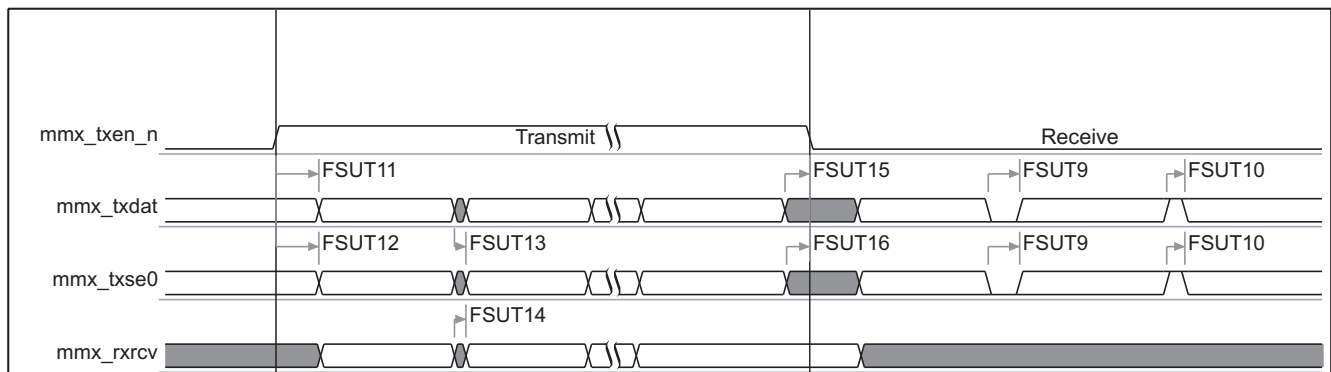

030-084

In mmx, x is equal to 0, 1, or 2.

Figure 6-47. Low-/Full-Speed USB – Bidirectional TLL 4-pin Mode

6.6.3.6 Multiport Full-Speed Universal Serial Bus (USB) – Bidirectional TLL 3-pin Mode

Table 6-93 and Table 6-94 assume testing over the recommended operating conditions (see Figure 6-48).

Table 6-92. Low-/Full-Speed USB Timing Conditions – Bidirectional TLL 3-pin Mode

| TIMING CONDITION PARAMETER | | VALUE | UNIT |
|----------------------------|------------------------|-------|------|
| Input Conditions | | | |
| t_R | Input signal rise time | 2 | ns |
| t_F | Input signal fall time | 2 | ns |

Table 6-92. Low-/Full-Speed USB Timing Conditions – Bidirectional TLL 3-pin Mode (continued)

| TIMING CONDITION PARAMETER | | VALUE | UNIT |
|----------------------------|-------------------------|-------|------|
| Output Conditions | | | |
| C _{LOAD} | Output load capacitance | 15 | pF |

Table 6-93. Low-/Full-Speed USB Timing Requirements – Bidirectional TLL 3-pin Mode

| NO. | PARAMETER | | 1.15 V | | 1.0 V | | UNIT |
|--------|-------------------------|--|--------|-----|-------|-----|------|
| | | | MIN | MAX | MIN | MAX | |
| FSUT17 | t _{d(DAT,SE0)} | Time duration, mmx_txdat and mmx_txse0 low together during transition | | 14 | | 14 | ns |
| FSUT18 | t _{d(DAT,SE0)} | Time duration, mmx_tsdat and mmx_txse0 high together during transition | | 8 | | 8 | ns |

Table 6-94. Low-/Full-Speed USB Switching Characteristics – Bidirectional TLL 3-pin Mode

| NO. | PARAMETER | | 1.15 V | | 1.0 V | | UNIT |
|--------|----------------------------|---|--------|------|-------|------|------|
| | | | MIN | MAX | MIN | MAX | |
| FSUT19 | t _{d(TXENH-DATV)} | Delay time, mmx_txen_n high to mmx_txdat valid | 81.8 | 84.8 | 81.8 | 84.8 | ns |
| FSUT20 | t _{d(TXENH-SE0V)} | Delay time, mmx_txen_n high to mmx_txse0 valid | 81.8 | 84.8 | 81.8 | 84.8 | ns |
| FSUT21 | t _{s(DAT-SE0)} | Skew between mmx_txdat and mmx_txse0 transition | | 1.5 | | 1.5 | ns |
| FSUT22 | t _{d(DATI-TXENL)} | Delay time, mmx_txdat invalid mmx_txen_n low | 81.8 | | 81.8 | | ns |
| FSUT23 | t _{d(SE0I-TXENL)} | Delay time, mmx_txse0 invalid mmx_txen_n low | 81.8 | | 81.8 | | ns |
| | t _{R(dat)} | Rise time, mmx_txdat | | 4 | | 4 | ns |
| | t _{F(dat)} | Fall time, mmx_txdat | | 4 | | 4 | ns |
| | t _{R(se0)} | Rise time, mmx_txse0 | | 4 | | 4 | ns |
| | t _{F(se0)} | Fall time, mmx_txse0 | | 4 | | 4 | ns |
| | t _{R(do)} | Rise time, mmx_txse0 | | 4 | | 4 | ns |
| | t _{F(do)} | Fall time, mmx_txse0 | | 4 | | 4 | ns |

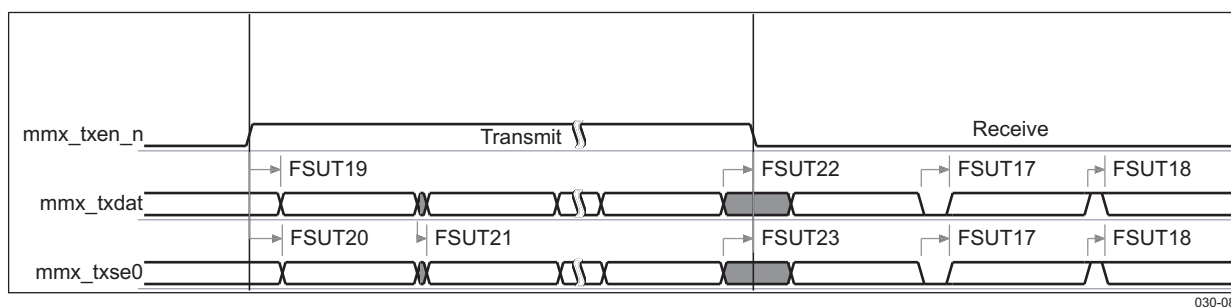

In mmx, x is equal to 0, 1, or 2.

Figure 6-48. Low-/Full-Speed USB – Bidirectional TLL 3-pin Mode

6.6.4 Multiport High-Speed Universal Serial Bus (USB) Timing

In addition to the full-speed USB controller, a high-speed (HS) USB OTG controller is instantiated inside OMAP3530/25. It allows high-speed transactions (up to 480 Mbit/s) on the USB ports 0, 1, 2, and 3.

- Port 0:
 - 12-bit slave mode (SDR)
- Port 1 and port 2:
 - 12-bit master mode (SDR)
 - 12-bit TLL master mode (SDR)

- 8-bit TLL master mode (DDR)
- Port 3:
 - 12-bit TLL master mode (SDR)
 - 8-bit TLL master mode (DDR)

6.6.4.1 High-Speed Universal Serial Bus (USB) on Port 0 – 12-bit Slave Mode

Table 6-96 and Table 6-97 assume testing over the recommended operating conditions (see Figure 6-49).

Table 6-95. High-Speed USB Timing Conditions – 12-bit Slave Mode

| TIMING CONDITION PARAMETER | | VALUE | UNIT |
|----------------------------|---------------------------|-------|------|
| Input Conditions | | | |
| t_r | Input Signal Rising Time | 2.00 | ns |
| t_f | Input Signal Falling Time | 2.00 | ns |
| Output Conditions | | | |
| C_{load} | Output Load Capacitance | 3.50 | pF |

Table 6-96. High-Speed USB Timing Requirements – 12-bit Slave Mode⁽¹⁾

| NO. | PARAMETER | | 1.15 V | | UNIT |
|------|--------------------|--|--------|--------|------|
| | | | MIN | MAX | |
| HSU0 | $f_p(CLK)$ | hsusb0_clk clock frequency ⁽²⁾⁽³⁾ | | 60.03 | MHz |
| | $t_j(CLK)$ | Cycle Jitter ⁽³⁾ , hsub0_clk | | 500.00 | ps |
| HSU3 | $t_s(DIRV-CLKH)$ | Setup time, hsub0_dir valid before hsub0_clk rising edge | 6.7 | | ns |
| | $t_s(NXTV-CLKH)$ | Setup time, hsub0_nxt valid before hsub0_clk rising edge | 6.7 | | ns |
| HSU4 | $t_h(CLKH-DIRIV)$ | Hold time, hsub0_dir valid after hsub0_clk rising edge | 0.0 | | ns |
| | $t_h(CLKH-NXT/IV)$ | Hold time, hsub0_nxt valid after hsub0_clk rising edge | 0.0 | | ns |
| HSU5 | $t_s(DATAV-CLKH)$ | Setup time, hsub0_data[0:7] valid before hsub0_clk rising edge | 6.7 | | ns |
| HSU6 | $t_h(CLKH-DATIV)$ | Hold time, hsub0_data[0:7] valid after hsub0_clk rising edge | 0.0 | | ns |

- (1) The timing requirements are assured for the cycle jitter error condition specified.
 (2) Related with the input maximum frequency supported by the I/F module.
 (3) Maximum cycle jitter supported by clk input clock.

Table 6-97. High-Speed USB Switching Characteristics – 12-bit Slave Mode

| NO. | PARAMETER | | 1.15 V | | UNIT |
|------|-------------------|--|--------|-----|------|
| | | | MIN | MAX | |
| HSU1 | $t_d(clkL-STPV)$ | Delay time, hsub0_clk high to output usb0_stp valid | | 9.0 | ns |
| | $t_d(clkL-STPIV)$ | Delay time, hsub0_clk high to output usb0_stp invalid | 0.5 | | ns |
| HSU2 | $t_d(clkL-DV)$ | Delay time, hsub0_clk high to output hsub0_data[0:7] valid | | 9.0 | ns |
| | $t_d(clkL-DIV)$ | Delay time, hsub0_clk high to output hsub0_data[0:7] invalid | 0.5 | | ns |
| | $t_r(do)$ | Rising time, output signals | | 2.0 | ns |
| | $t_f(do)$ | Falling time, output signals | | 2.0 | ns |

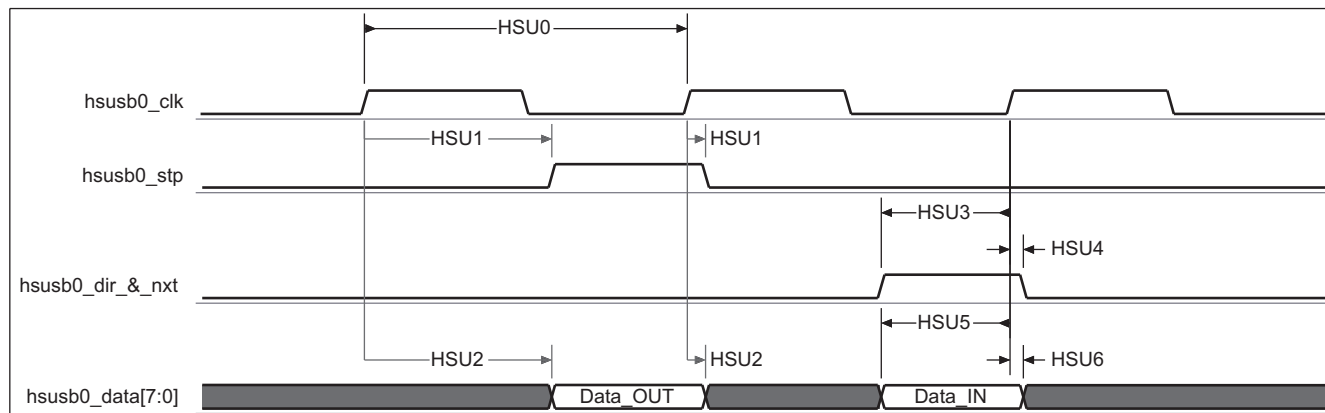

030-086

Figure 6-49. High-Speed USB – 12-bit Slave Mode

6.6.4.2 High-Speed Universal Serial Bus (USB) on Ports 1 and 2 – 12-bit Master Mode

Table 6-99 and Table 6-100 assume testing over the recommended operating conditions (see Figure 6-50).

Table 6-98. High-Speed USB Timing Conditions – 12-bit Master Mode

| TIMING CONDITION PARAMETER | | VALUE | UNIT |
|----------------------------|-------------------------|-------|------|
| Input Conditions | | | |
| t_R | Input signal rise time | 2 | ns |
| t_F | Input signal fall time | 2 | ns |
| Output Conditions | | | |
| C_{LOAD} | Output load capacitance | 3 | pF |

Table 6-99. High-Speed USB Timing Requirements – 12-bit Master Mode⁽¹⁾

| NO. | PARAMETER | | 1.15 V | | UNIT |
|------|---------------------|--|--------|-----|------|
| | | | MIN | MAX | |
| HSU3 | $t_{S(DIRV-CLKH)}$ | Setup time, hsubx_dir valid before hsubx_clk rising edge | 9.3 | | ns |
| | $t_{S(NXTV-CLKH)}$ | Setup time, hsubx_nxt valid before hsubx_clk rising edge | 9.3 | | ns |
| HSU4 | $t_{H(CLKH-DIRIV)}$ | Hold time, hsubx_dir valid after hsubx_clk rising edge | 0.2 | | ns |
| | $t_{H(CLKH-NXTIV)}$ | Hold time, hsubx_nxt valid after hsubx_clk rising edge | 0.2 | | ns |
| HSU5 | $t_{S(DATAV-CLKH)}$ | Setup time, hsubx_data[0:7] valid before hsubx_clk rising edge | 9.3 | | ns |
| HSU6 | $t_{H(CLKH-DATIV)}$ | Hold time, hsubx_data[0:7] valid after hsubx_clk rising edge | 0.2 | | ns |

(1) In hsubx, x is equal to 1 or 2.

Table 6-100. High-Speed USB Switching Characteristics – 12-bit Master Mode⁽¹⁾

| NO. | PARAMETER | | 1.15 V | | UNIT |
|------|--------------------|--|--------|-----|------|
| | | | MIN | MAX | |
| HSU0 | $f_{p(CLK)}$ | hsubx_clk clock frequency | | 60 | MHz |
| | $t_{j(CLK)}$ | Jitter standard deviation ⁽²⁾ , hsubx_clk | | 200 | ps |
| HSU1 | $t_{d(CLK-STPV)}$ | Delay time, hsubx_clk high to output hsubx_stp valid | | 13 | ns |
| | $t_{d(CLK-STPIV)}$ | Delay time, hsubx_clk high to output hsubx_stp invalid | 2 | | ns |
| HSU2 | $t_{d(CLK-DV)}$ | Delay time, hsubx_clk high to output hsubx_data[0:7] valid | | 13 | ns |
| | $t_{d(CLK-DIV)}$ | Delay time, hsubx_clk high to output hsubx_data[0:7] invalid | 2 | | ns |

(1) In hsubx, x is equal to 1 or 2.

(2) The jitter probability density can be approximated by a Gaussian function.

Table 6-100. High-Speed USB Switching Characteristics – 12-bit Master Mode (continued)

| N O. | PARAMETER | | 1.15 V | | UNIT |
|------|-------------|---------------------------|--------|-----|------|
| | | | MIN | MAX | |
| | $t_{R(do)}$ | Rise time, output signals | | 2 | ns |
| | $t_{F(do)}$ | Fall time, output signals | | 2 | ns |

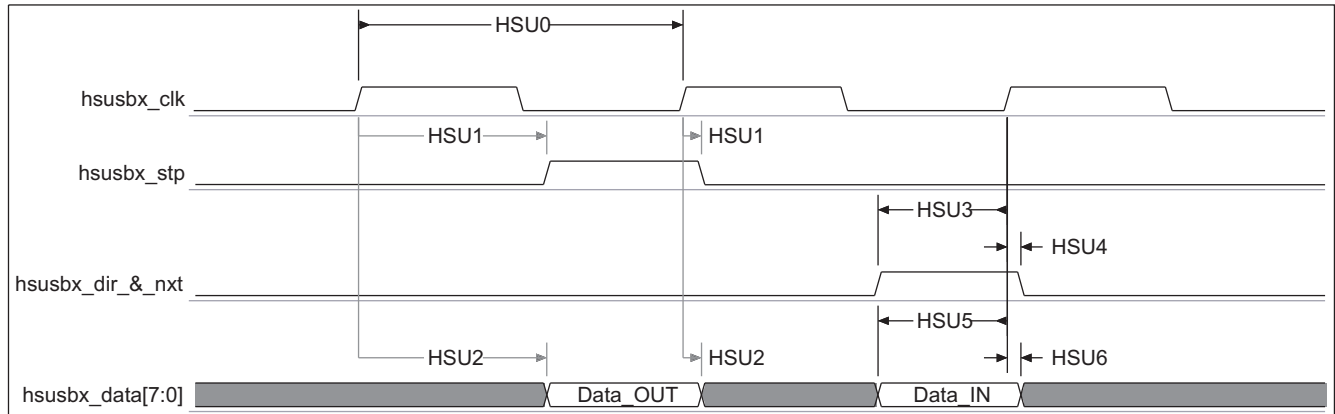

030-087

In hsubx, x is equal to 1 or 2.

Figure 6-50. High-Speed USB – 12-bit Master Mode

6.6.4.3 High-Speed Universal Serial Bus (USB) on Ports 1, 2, and 3 – 12-bit TLL Master Mode

Table 6-102 and Table 6-103 assume testing over the recommended operating conditions (see Figure 6-51).

Table 6-101. High-Speed USB Timing Conditions – 12-bit TLL Master Mode

| TIMING CONDITION PARAMETER | | VALUE | UNIT |
|----------------------------|-------------------------|-------|------|
| Input Conditions | | | |
| t_R | Input signal rise time | 2 | ns |
| t_F | Input signal fall time | 2 | ns |
| Output Conditions | | | |
| C_{LOAD} | Output load capacitance | 3 | pF |

Table 6-102. High-Speed USB Timing Requirements – 12-bit TLL Master Mode⁽¹⁾

| NO. | PARAMETER | | 1.15 V | | UNIT |
|------|---------------------|--|--------|-----|------|
| | | | MIN | MAX | |
| HSU2 | $t_{s(STPV-CLKH)}$ | Setup time, hsubx_tll_stp valid before hsubx_tll_clk rising edge | 6 | | ns |
| HSU3 | $t_{s(CLKH-STPIV)}$ | Hold time, hsubx_tll_stp valid after hsubx_tll_clk rising edge | 0 | | ns |
| HSU4 | $t_{s(DATAV-CLKH)}$ | Setup time, hsubx_tll_data[7:0] valid before hsubx_tll_clk rising edge | 6 | | ns |
| HSU5 | $t_{h(CLKH-DATIV)}$ | Hold time, hsubx_tll_data[7:0] valid after hsubx_tll_clk rising edge | 0 | | ns |

(1) In hsubx, x is equal to 1, 2, or 3.

Table 6-103. High-Speed USB Switching Characteristics – 12-bit TLL Master Mode⁽¹⁾

| NO. | PARAMETER | | 1.15 V | | UNIT |
|------|--------------|-------------------------------|--------|-----|------|
| | | | MIN | MAX | |
| HSU0 | $f_{p(CLK)}$ | hsubx_tll_clk clock frequency | | 60 | MHz |

(1) In hsubx, x is equal to 1, 2, or 3.

Table 6-103. High-Speed USB Switching Characteristics – 12-bit TLL Master Mode (continued)

| NO. | PARAMETER | | 1.15 V | | UNIT |
|------|---------------------|--|--------|-----|------|
| | | | MIN | MAX | |
| | $t_{j(CLK)}$ | Jitter standard deviation ⁽²⁾ , hsubsx_tll_clk | | 200 | ps |
| HSU6 | $t_{d(CLKL-DIRV)}$ | Delay time, hsubsx_tll_clk high to output hsubsx_tll_dir valid | | 9 | ns |
| | $t_{d(CLKL-DIRIV)}$ | Delay time, hsubsx_tll_clk high to output hsubsx_tll_dir invalid | 0 | | ns |
| | $t_{d(CLKL-NXTV)}$ | Delay time, hsubsx_tll_clk high to output hsubsx_tll_nxt valid | | 9 | ns |
| | $t_{d(CLKL-NXTIV)}$ | Delay time, hsubsx_tll_clk high to output hsubsx_tll_nxt invalid | 0 | | ns |
| HSU7 | $t_{d(CLKL-DV)}$ | Delay time, hsubsx_tll_clk high to output hsubsx_tll_data[7:0] valid | | 9 | ns |
| | $t_{d(CLKL-DIV)}$ | Delay time, hsubsx_tll_clk high to output hsubsx_tll_data[7:0] invalid | 0 | | ns |
| | $t_{R(do)}$ | Rise time, output signals | | 2 | ns |
| | $t_{F(do)}$ | Fall time, output signals | | 2 | ns |

(2) The jitter probability density can be approximated by a Gaussian function.

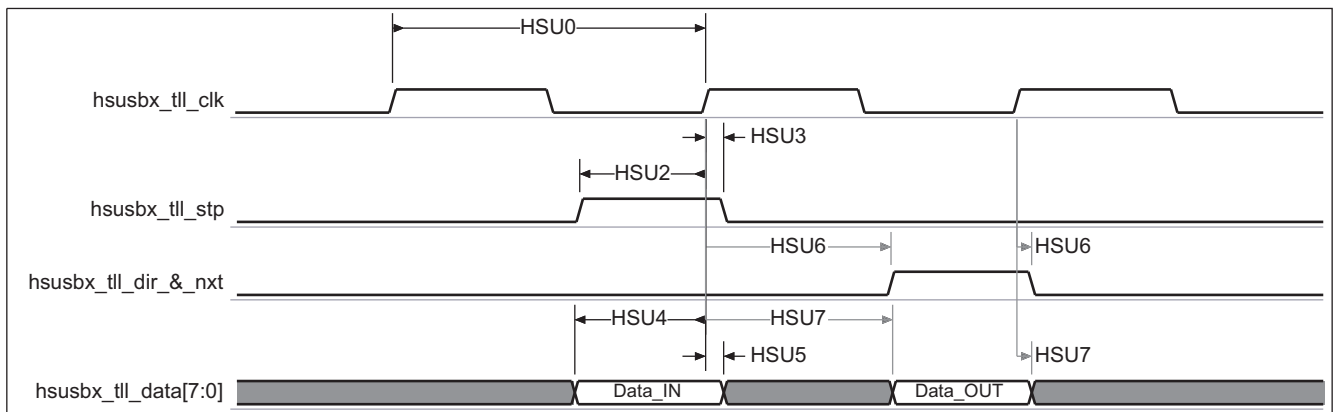

030-088

In hsubsx, x is equal to 1, 2, or 3.

Figure 6-51. High-Speed USB – 12-bit TLL Master Mode

6.6.4.4 High-Speed Universal Serial Bus (USB) on Ports 1, 2, and 3 – 8-bit TLL Master Mode

Table 6-105 and Table 6-106 assume testing over the recommended operating conditions (see Figure 6-52).

Table 6-104. High-Speed USB Timing Conditions – 8-bit TLL Master Mode

| TIMING CONDITION PARAMETER | | VALUE | UNIT |
|----------------------------|-------------------------|-------|------|
| Input Conditions | | | |
| t_R | Input signal rise time | 2 | ns |
| t_F | Input signal fall time | 2 | ns |
| Output Conditions | | | |
| C_{LOAD} | Output load capacitance | 3 | pF |

Table 6-105. High-Speed USB Timing Requirements – 8-bit TLL Master Mode⁽¹⁾

| NO. | PARAMETER | | 1.15 V | | UNIT |
|------|---------------------|--|--------|-----|------|
| | | | MIN | MAX | |
| HSU2 | $t_{s(STPV-CLKH)}$ | Setup time, hsubsx_tll_stp valid before hsubsx_tll_clk rising edge | 6 | | ns |
| HSU3 | $t_{s(CLKH-STPIV)}$ | Hold time, hsubsx_tll_stp valid after hsubsx_tll_clk rising edge | 0 | | ns |
| HSU4 | $t_{s(DATAV-CLKH)}$ | Setup time, hsubsx_tll_data[3:0] valid before hsubsx_tll_clk rising edge | 3 | | ns |

(1) In hsubsx, x is equal to 1, 2, or 3.

Table 6-105. High-Speed USB Timing Requirements – 8-bit TLL Master Mode (continued)

| NO. | PARAMETER | | 1.15 V | | UNIT |
|------|---------------------|--|--------|-----|------|
| | | | MIN | MAX | |
| HSU5 | $t_{h(CLKH-DATIV)}$ | Hold time, <code>hsusbx_tll_data[3:0]</code> valid after <code>hsusbx_tll_clk</code> rising edge | -0.8 | | ns |

Table 6-106. High-Speed USB Switching Characteristics – 8-bit TLL Master Mode⁽¹⁾

| NO. | PARAMETER | | 1.15 V | | UNIT |
|------|-------------------|--|--------|-------|------|
| | | | MIN | MAX | |
| HSU0 | $f_p(CLK)$ | <code>hsusbx_tll_clk</code> clock frequency | | 60 | MHz |
| | $t_j(CLK)$ | Jitter standard deviation ⁽²⁾ , <code>hsusbx_tll_clk</code> | | 200 | ps |
| HSU1 | $t_j(CLK)$ | Duty cycle, <code>hsusbx_tll_clk</code> pulse duration (low and high) | 47.6% | 52.4% | |
| HSU6 | $t_d(CLKL-DIRV)$ | Delay time, <code>hsusbx_tll_clk</code> high to output <code>hsusbx_tll_dir</code> valid | | 9 | ns |
| | $t_d(CLKL-DIRIV)$ | Delay time, <code>hsusbx_tll_clk</code> high to output <code>hsusbx_tll_dir</code> invalid | 0 | | ns |
| | $t_d(CLKL-NXTV)$ | Delay time, <code>hsusbx_tll_clk</code> high to output <code>hsusbx_tll_nxt</code> valid | | 9 | ns |
| | $t_d(CLKL-NXTIV)$ | Delay time, <code>hsusbx_tll_clk</code> high to output <code>hsusbx_tll_nxt</code> invalid | 0 | | ns |
| HSU7 | $t_d(CLKL-DV)$ | Delay time, <code>hsusbx_tll_clk</code> high to output <code>hsusbx_tll_data[3:0]</code> valid | | 4 | ns |
| HSU8 | $t_d(CLKL-DIV)$ | Delay time, <code>hsusbx_tll_clk</code> high to output <code>hsusbx_tll_data[3:0]</code> invalid | 0 | | ns |
| | $t_R(do)$ | Rise time, output signals | | 2 | ns |
| | $t_F(do)$ | Fall time, output signals | | 2 | ns |

- (1) In `hsusbx`, x is equal to 1, 2, or 3.
- (2) The jitter probability density can be approximated by a Gaussian function.

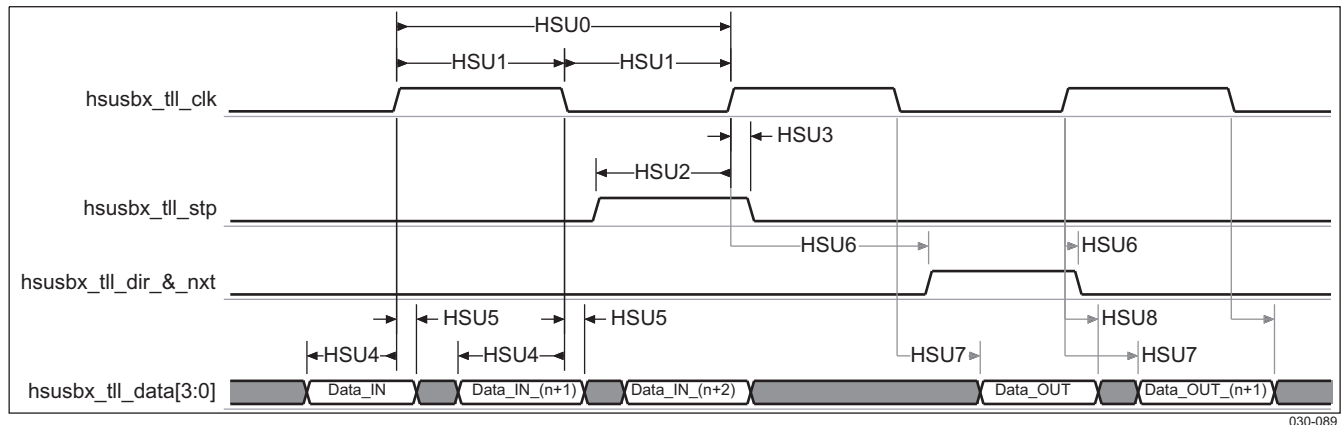

In `hsusbx`, x is equal to 1, 2, or 3.

Figure 6-52. High-Speed USB – 8-bit TLL Master Mode

6.6.5 I²C Interface

The multimaster I²C peripheral provides an interface between two or more devices via an I²C serial bus. The I²C controller supports the multimaster mode which allows more than one device capable of controlling the bus to be connected to it. Each I²C device is recognized by a unique address and can operate as either transmitter or receiver, according to the function of the device. In addition to being a transmitter or receiver, a device connected to the I²C bus can also be considered as master or slave when performing data transfers. This data transfer is carried out via two serial bidirectional wires:

- An SDA data line
- An SCL clock line

The following sections illustrate the data transfer is in master or slave configuration with 7-bit addressing format. The I²C interface is compliant with Philips I²C specification version 2.1. It supports standard mode (up to 100K bits/s), fast mode (up to 400K bits/s) and high-speed mode (up to 3.4Mb/s) .

6.6.5.1 I²C Standard/Fast-Speed Mode

Table 6-107. I²C Standard/Fast-Speed Mode Timings

| NO. | PARAMETER ⁽¹⁾ | | Standard Mode | | Fast Mode | | UNIT |
|-----|-----------------------------|---|------------------|---------------------|--------------------|--------------------|------|
| | | | MIN | MAX | MIN | MAX | |
| | f _{SCL} | Clock Frequency, i2cX_scl | | 100 | | 400 | kHz |
| I1 | t _{w(SCLH)} | Pulse Duration, i2cX_scl high | 4 | | 0.6 | | μs |
| I2 | t _{w(SCLL)} | Pulse Duration, i2cX_scl low | 4.7 | | 1.3 | | μs |
| I3 | t _{su(SDAV-SCLH)} | Setup time, i2cX_sda valid before i2cX_scl active level | 250 | | 100 ⁽²⁾ | | ns |
| I4 | t _{h(SCLH-SDAV)} | Hold time, i2cX_sda valid after i2cX_scl active level | 0 ⁽³⁾ | 3.45 ⁽⁴⁾ | 0 ⁽³⁾ | 0.9 ⁽⁴⁾ | μs |
| I5 | t _{su(SDAL-SCLH)} | Setup time, i2cX_scl high after i2cX_sda low (for a START ⁽⁵⁾ condition or a repeated START condition) | 4.7 | | 0.6 | | μs |
| I6 | t _{h(SCLH-SDAH)} | Hold time, i2cX_sda low level after i2cX_scl high level (STOP condition) | 4 | | 0.6 | | μs |
| I7 | t _{h(SCLH-RSTART)} | Hold time, i2cX_sda low level after i2cX_scl high level (for a repeated START condition) | 4 | | 0.6 | | μs |
| I8 | t _{w(SDAH)} | Pulse duration, i2cX_sda high between STOP and START conditions | 4.7 | | 1.3 | | μs |
| | t _{R(SCL)} | Rise time, i2cX_scl | | 1000 | | 300 | ns |
| | t _{F(SCL)} | Fall time, i2cX_scl | | 300 | | 300 | ns |
| | t _{R(SDA)} | Rise time, i2cX_sda | | 1000 | | 300 | ns |
| | t _{F(SDA)} | Fall time, i2cX_sda | | 300 | | 300 | ns |
| | CB | Capacitive load for each bus line | | 60 ⁽⁶⁾ | | 60 ⁽⁶⁾ | pF |

- (1) In i2cX, X is equal to 1, 2, 3, or 4. Note that I2C4 is master transmitter only.
- (2) A fast-mode I²C-bus device can be used in a standard-mode I²C-bus system, but the requirement t_{su(SDAV-SCLH)} ≥ 250 ns must then be met. This is automatically the case if the device does not stretch the low period of the i2cx_scl. If such a device does stretch the low period of the i2cx_scl, it must output the next data bit to the i2cx_sda line t_{r(SDA)} max + t_{su(SDAV-SCLH)} = 1000 + 250 = 1250 ns (according to the standard-mode I²C-bus specification) before the i2cx_scl line is released.
- (3) The device provides (via the I²C bus) a hold time of at least 300 ns for the i2cx_sda signal (refer to the fall and rise time of i2cx_scl) to bridge the undefined region of the falling edge of i2cx_scl.
- (4) The maximum t_{h(SCLH-SDA)} has only to be met if the device does not stretch the low period of the i2cx_scl signal.
- (5) After this time, the first clock is generated.
- (6) Maximum reference load for i2c4_scl and i2c4_sda is CB = 15 pF.

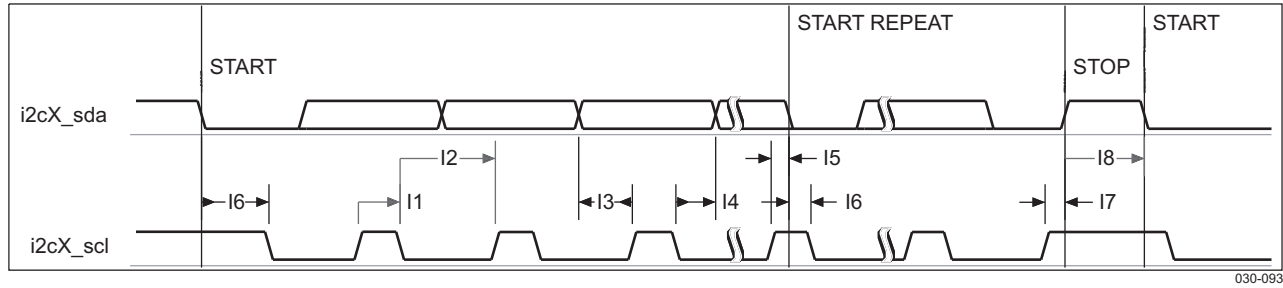

Figure 6-53. I²C – Standard/Fast Mode

6.6.5.2 I²C High-Speed Mode

Table 6-108. I²C HighSpeed Mode Timings⁽¹⁾⁽²⁾

| NO. | PARAMETER | | CB = 100 pF MAX | | CB = 400 pF MAX | | UNIT |
|-----|-----------------------------|---|--------------------|-------------------|--------------------|-----|------|
| | | | MIN | MAX | MIN | MAX | |
| | f _{SCL} | Clock frequency, i2cX_scl | | 3.4 | | 1.7 | MHz |
| I1 | t _{w(SCLH)} | Pulse duration, i2cX_scl high | 60 ⁽³⁾ | | 120 ⁽³⁾ | | μs |
| I2 | t _{w(SCLL)} | Pulse duration, i2cX_scl low | 160 ⁽³⁾ | | 320 ⁽³⁾ | | μs |
| I3 | t _{su(SDAV-SCLH)} | Setup time, i2cX_sda valid before i2cX_scl active level | 10 | | 10 | | ns |
| I4 | t _{h(SCLH-SDAV)} | Hold time, i2cX_sda valid after i2cX_scl active level | 0 ⁽²⁾ | 70 | 0 ⁽²⁾ | 150 | μs |
| I5 | t _{su(SDAL-SCLH)} | Setup time, i2cX_scl high after i2cX_sda low (for a START ⁽⁴⁾ condition or a repeated START condition) | 160 | | 160 | | μs |
| I6 | t _{h(SCLH-SDAH)} | Hold time, i2cX_sda low level after i2cX_scl high level (STOP condition) | 160 | | 160 | | μs |
| I7 | t _{h(SCLH-RSTART)} | Hold time, i2cX_sda low level after i2cX_scl high level (for a repeated START condition) | 160 | | 160 | | ns |
| | t _{R(SCL)} | Rise time, i2cX_scl | | 40 | | 80 | ns |
| | t _{R(SCL)} | Rise time, i2cX_scl after a repeated START condition and after a bit acknowledge | | 80 | | 160 | ns |
| | t _{F(SCL)} | Fall time, i2cX_scl | | 40 | | 80 | ns |
| | t _{R(SDA)} | Rise time, i2cX_sda | | 80 | | 160 | ns |
| | t _{F(SDA)} | Fall time, i2cX_sda | | 80 | | 160 | ns |
| | C _B | Capacitive load for each bus line | | 60 ⁽⁵⁾ | | pF | |

- (1) In i2cX, X is equal to 1, 2, 3, or 4. Note that I2C4 is master transmitter only.
- (2) The device provides (via the I²C bus) a hold time of at least 300 ns for the i2cx_sda signal (refer to the fall and rise time of i2cx_scl) to bridge the undefined region of the falling edge of i2cx_scl.
- (3) HS-mode master devices generate a serial clock signal with a high to low ratio of 1 to 2. t_{w(SCLL)} > 2 × t_{w(SCLH)}.
- (4) After this time, the first clock is generated.
- (5) Maximum reference load for i2c4_scl and i2c4_sda is C_B = 15 pF.

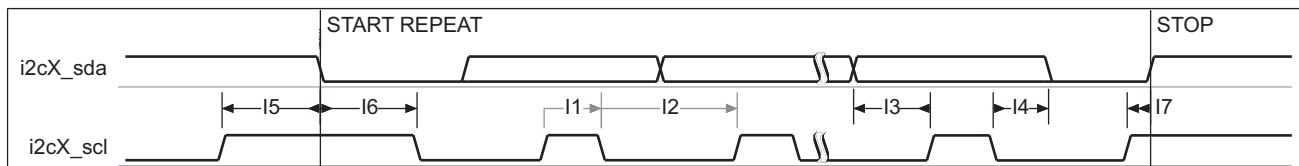

030-094

Figure 6-54. I²C – High-Speed Mode⁽¹⁾⁽²⁾⁽³⁾

- (1) HS-mode master devices generate a serial clock signal with a high-to-low ratio of 1 to 2. t_{w(SCLL)} > 2 × t_{w(SCLH)}.
- (2) In i2cX, X is equal to 1, 2, 3, or 4. Note that I2C4 is master transmitter only.
- (3) After this time, the first clock is generated.

Table 6-109. Correspondence Standard vs. TI Timing References

| | TI-OMAP | STANDARD-I ² C | |
|----|----------------------------|---------------------------|---------------------|
| | | S/F Mode | HS Mode |
| | f _{SCL} | F _{SCL} | F _{SCLH} |
| I1 | t _{w(SCLH)} | T _{HIGH} | T _{HIGH} |
| I2 | t _{w(SCLL)} | T _{LOW} | T _{LOW} |
| I3 | t _{su(SDAV-SCLH)} | T _{SU;DAT} | T _{SU;DAT} |
| I4 | t _{h(SCLH-SDAV)} | T _{SU;DAT} | T _{SU;DAT} |
| I5 | t _{su(SDAL-SCLH)} | T _{SU;STA} | T _{SU;STA} |

Table 6-109. Correspondence Standard vs. TI Timing References (continued)

| | TI-OMAP | STANDARD-I ² C | |
|----|----------------------|---------------------------|--------------|
| | | S/F Mode | HS Mode |
| 16 | $t_{h(SCLH-SDAH)}$ | $T_{HD;STA}$ | $T_{HD;STA}$ |
| 17 | $t_{h(SCLH-RSTART)}$ | $T_{SU;STO}$ | $T_{SU;STO}$ |
| 18 | $t_w(SDAH)$ | T_{BUF} | |

6.6.6 HDQ / 1-Wire Interfaces

This module is intended to work with both the HDQ and the 1-Wire protocols. The protocols use a single wire to communicate between the master and the slave. The protocols employ an asynchronous return to 1 mechanism where, after any command, the line is pulled high.

6.6.6.1 HDQ Protocol

Table 6-110 and Table 6-111 assume testing over the recommended operating conditions (see Figure 6-55 through Figure 6-58).

Table 6-110. HDQ Timing Requirements

| PARAMETER | DESCRIPTION | MIN | MAX | UNIT |
|------------|--|-----|-----|---------|
| t_{CYCD} | Bit window | 253 | | μs |
| t_{HW1} | Reads 1 | | 68 | |
| t_{HW0} | Reads 0 | 180 | | |
| t_{RSPS} | Command to host respond ⁽¹⁾ | | | |

(1) Defined by software.

Table 6-111. HDQ Switching Characteristics

| PARAMETER | DESCRIPTION | MIN | TYP | MAX | UNIT |
|------------|----------------|-----|-----|-----|---------|
| t_B | Break timing | | 193 | | μs |
| t_{BR} | Break recovery | | 63 | | |
| t_{CYCH} | Bit window | | 253 | | |
| t_{DW1} | Sends1 (write) | | 1.3 | | |
| t_{DW0} | Sends0 (write) | | 101 | | |

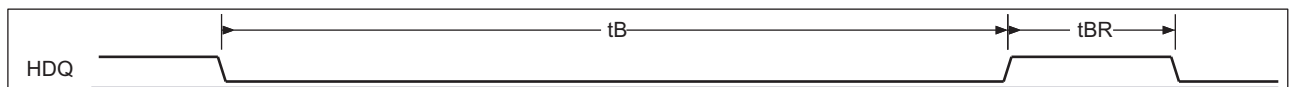

030-095

Figure 6-55. HDQ Break (Reset) Timing

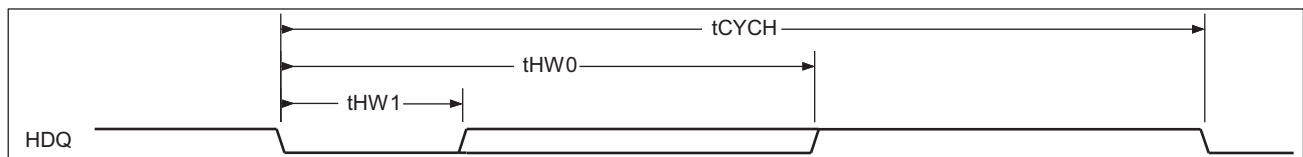

030-096

Figure 6-56. HDQ Read Bit Timing (Data)

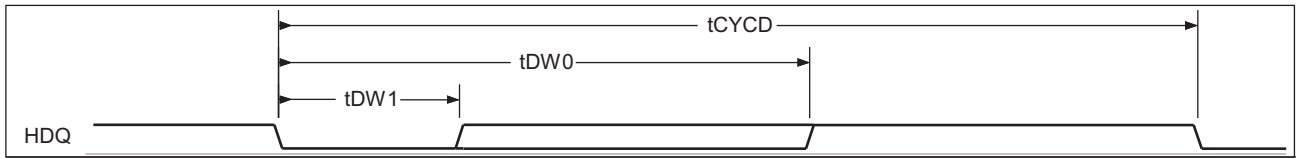

030-097

Figure 6-57. HDQ Write Bit Timing (Command/Address or Data)

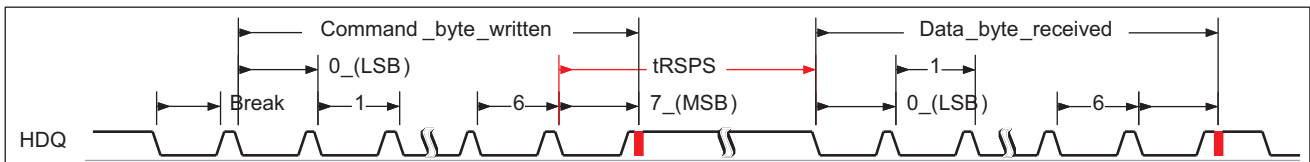

030-098

Figure 6-58. HDQ Communication Timing

6.6.6.2 1-Wire Protocol

Table 6-112 and Table 6-113 assume testing over the recommended operating conditions (see Figure 6-59 through Figure 6-61).

Table 6-112. 1-Wire Timing Requirements

| PARAMETER | DESCRIPTION | MIN | MAX | UNIT |
|-------------------------------------|---------------------------|-----------------------|-----|------|
| t _{PDH} | Presence pulse delay high | | 68 | μs |
| t _{PDL} | Presence pulse delay low | 68 - t _{PDH} | | |
| t _{RDV} + t _{REL} | Read bit-zero time | | 102 | |

Table 6-113. 1-Wire Switching Characteristics

| PARAMETER | DESCRIPTION | MIN | TYP | MAX | UNIT |
|-------------------|----------------------|-----|-----|-----|------|
| t _{RSTL} | Reset time low | | 484 | | μs |
| t _{RSTH} | Reset time high | | 484 | | |
| t _{SLOT} | Write bit cycle time | | 102 | | |
| t _{LOW1} | Write bit-one time | | 1.3 | | |
| t _{LOW0} | Write bit-zero time | | 101 | | |
| t _{REC} | Recovery time | | 134 | | |
| t _{LOWR} | Read bit strobe time | | 13 | | |

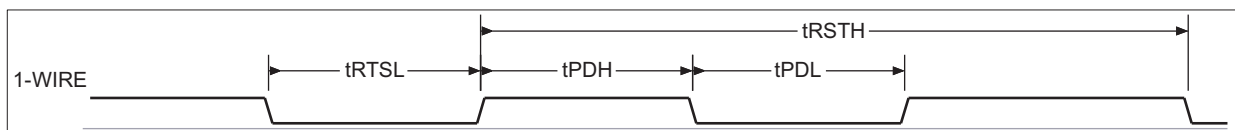

030-099

Figure 6-59. 1-Wire Break (Reset) Timing

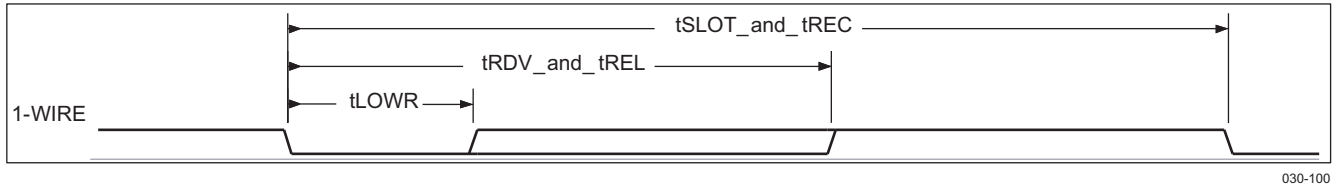

Figure 6-60. 1-Wire Read Bit Timing (Data)

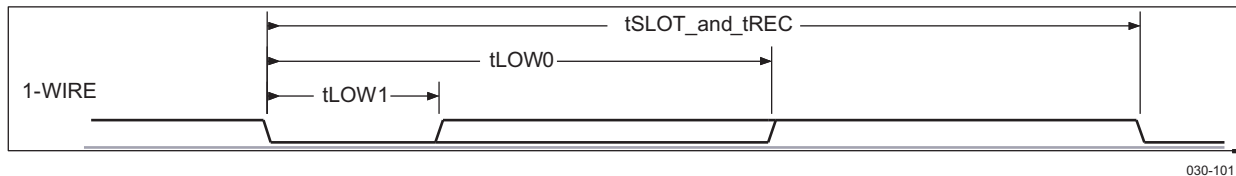

Figure 6-61. 1-Wire Write Bit Timing (Command/Address or Data)

6.6.7 UART IrDA Interface

The IrDA module can operate in three different modes:

- Slow infrared (SIR) (≤ 115.2 Kbits/s)
- Medium infrared (MIR) (0.576 Mbits/s and 1.152 Mbits/s)
- Fast infrared (FIR) (4 Mbits/s)

For more information about this interface, see the UART/IrDA chapter in the *OMAP35x Technical Reference Manual (TRM)* [literature number [SPRUF98](#)].

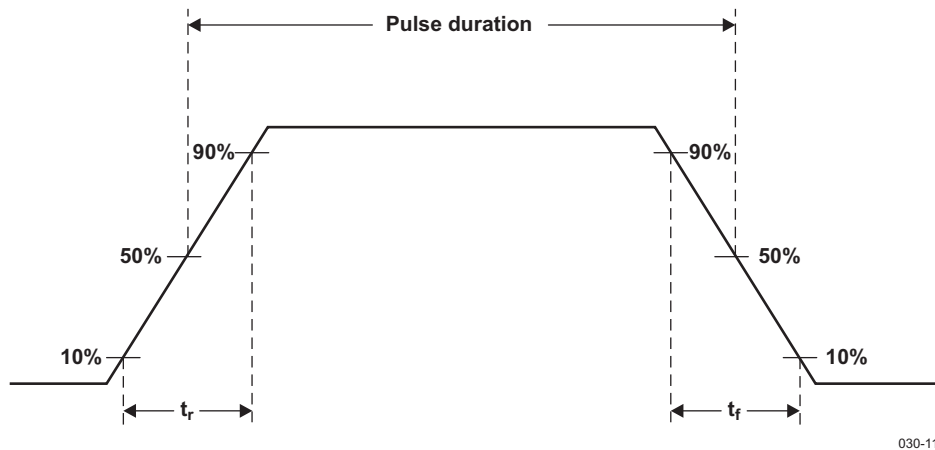

Figure 6-62. UART IrDA Pulse Parameters

6.6.7.1 IrDA—Receive Mode

Table 6-114. UART IrDA—Signaling Rate and Pulse Duration—Receive Mode

| SIGNALING RATE | ELECTRICAL PULSE DURATION | | | UNIT |
|----------------|---------------------------|---------|-------|---------|
| | MIN | NOMINAL | MAX | |
| SIR | | | | |
| 2.4 Kbit/s | 1.41 | 78.1 | 88.55 | μ s |
| 9.6 Kbit/s | 1.41 | 19.5 | 22.13 | μ s |
| 19.2 Kbit/s | 1.41 | 9.75 | 11.07 | μ s |

**Table 6-114. UART IrDA—Signaling Rate and Pulse Duration—Receive Mode
(continued)**

| SIGNALING RATE | ELECTRICAL PULSE DURATION | | | UNIT |
|---------------------------|---------------------------|---------|-------|------|
| | MIN | NOMINAL | MAX | |
| 38.4 Kbit/s | 1.41 | 4.87 | 5.96 | μs |
| 57.6 Kbit/s | 1.41 | 3.25 | 4.34 | μs |
| 115.2 Kbit/s | 1.41 | 1.62 | 2.23 | μs |
| MIR | | | | |
| 0.576 Mbit/s | 297.2 | 416 | 518.8 | ns |
| 1.152 Mbit/s | 149.6 | 208 | 258.4 | ns |
| FIR | | | | |
| 4.0 Mbit/s (Single pulse) | 67 | 125 | 164 | ns |
| 4.0 Mbit/s (Double pulse) | 190 | 250 | 289 | ns |

Table 6-115. UART IrDA—Rise and Fall Time—Receive Mode

| | PARAMETER | MAX | UNIT |
|-------|--------------------------------|-----|------|
| t_R | Rising time, uart3_rx_irrx | 200 | ns |
| t_F | Falling time, uart3_rx_irrx | 200 | ns |

6.6.7.2 IrDA—Transmit Mode

Table 6-116. UART IrDA—Signaling Rate and Pulse Duration—Transmit Mode

| SIGNALING RATE | ELECTRICAL PULSE DURATION | | | UNIT |
|---------------------------|---------------------------|---------|------|------|
| | MIN | NOMINAL | MAX | |
| SIR | | | | |
| 2.4 Kbit/s | 78.1 | 78.1 | 78.1 | μs |
| 9.6 Kbit/s | 19.5 | 19.5 | 19.5 | μs |
| 19.2 Kbit/s | 9.75 | 9.75 | 9.75 | μs |
| 38.4 Kbit/s | 4.87 | 4.87 | 4.87 | μs |
| 57.6 Kbit/s | 3.25 | 3.25 | 3.25 | μs |
| 115.2 Kbit/s | 1.62 | 1.62 | 1.62 | μs |
| MIR | | | | |
| 0.576 Mbit/s | 414 | 416 | 419 | ns |
| 1.152 Mbit/s | 206 | 208 | 211 | ns |
| FIR | | | | |
| 4.0 Mbit/s (Single pulse) | 123 | 125 | 128 | ns |
| 4.0 Mbit/s (Double pulse) | 248 | 250 | 253 | ns |

6.7 Removable Media Interfaces

6.7.1 High-Speed Multimedia Memory Card (MMC) and Secure Digital IO Card (SDIO) Timing

The MMC/SDIO host controller provides an interface to high-speed and standard MMC, SD memory cards, or SDIO cards. The application interface is responsible for managing transaction semantics. The MMC/SDIO host controller deals with MMC/SDIO protocol at transmission level, packing data, adding CRC, start/end bit, and checking for syntactical correctness.

There are three MMC interfaces on the OMAP3530/25:

- MMC/SD/SDIO Interface 1:
 - 1.8 V/3 V support
 - 8 bits
- MMC/SD/SDIO Interface 2:
 - 1.8 V support
 - 8 bits
 - 4 bits with external transceiver allowing to support 3 V peripherals. Transceiver direction control signals are multiplexed with the upper four data bits.
- MMC/SD/SDIO Interface 3:
 - 1.8 V support
 - 8 bits

6.7.1.1 MMC/SD/SDIO in SD Identification Mode

Table 6-118 and Table 6-119 assume testing over the recommended operating conditions and electrical characteristic conditions.

Table 6-117. MMC/SD/SDIO Timing Conditions – SD Identification Mode

| TIMING CONDITION PARAMETER | | VALUE | UNIT |
|-------------------------------|-------------------------|-------|------|
| SD Identification Mode | | | |
| Input Conditions | | | |
| t_R | Input signal rise time | 10 | ns |
| t_F | Input signal fall time | 10 | ns |
| Output Conditions | | | |
| C_{LOAD} | Output load capacitance | 40 | pF |

Table 6-118. MMC/SD/SDIO Timing Requirements – SD Identification Mode⁽¹⁾⁽²⁾⁽³⁾

| NO. | PARAMETER | 1.15 V | | 1.0 V | | UNIT |
|---|-----------------------|--|-----|--------|-----|------|
| | | MIN | MAX | MIN | MAX | |
| SD Identification Mode | | | | | | |
| MMC/SD/SDIO Interface 1 (1.8 V IO) | | | | | | |
| HSSD3/SD3 | $t_{su}(CMDV-CLKIH)$ | Setup time, mmc1_cmd valid before mmc1_clk rising clock edge | | 1198.4 | | ns |
| HSSD4/SD4 | $t_{su}(CLKIH-CMDIV)$ | Hold time, mmc1_cmd valid after mmc1_clk rising clock edge | | 1249.2 | | ns |
| MMC/SD/SDIO Interface 1 (3.0 V IO) | | | | | | |
| HSSD3/SD3 | $t_{su}(CMDV-CLKIH)$ | Setup time, mmc1_cmd valid before mmc1_clk rising clock edge | | 1198.4 | | ns |
| HSSD4/SD4 | $t_{su}(CLKIH-CMDIV)$ | Hold time, mmc1_cmd valid after mmc1_clk rising clock edge | | 1249.2 | | ns |
| MMC/SD/SDIO Interface 2 | | | | | | |

(1) Timing parameters are referred to output clock specified in Table 6-119.

(2) The timing requirements are assured for the cycle jitter and duty cycle error conditions specified in Table 6-119.

(3) Corresponding figures showing timing parameters are common with other interface modes. (See SD and HS SD modes).

Table 6-118. MMC/SD/SDIO Timing Requirements – SD Identification Mode (continued)

| NO. | PARAMETER | | 1.15 V | | 1.0 V | | UNIT |
|--------------------------------|-----------------------|--|--------|-----|--------|-----|------|
| | | | MIN | MAX | MIN | MAX | |
| HSSD3/SD3 | $t_{su}(CMDV-CLKIH)$ | Setup time, mmc2_cmd valid before mmc2_clk rising clock edge | 1198.4 | | 1198.4 | | ns |
| HSSD4/SD4 | $t_{su}(CLKIH-CMDIV)$ | Hold time, mmc2_cmd valid after mmc2_clk rising clock edge | 1249.2 | | 1249.2 | | ns |
| MMC/SD/SDIO Interface 3 | | | | | | | |
| HSSD3/SD3 | $t_{su}(CMDV-CLKIH)$ | Setup time, mmc3_cmd valid before mmc3_clk rising clock edge | 1198.4 | | 1198.4 | | ns |
| HSSD4/SD4 | $t_{su}(CLKIH-CMDIV)$ | Hold time, mmc3_cmd valid after mmc3_clk rising clock edge | 1249.2 | | 1249.2 | | ns |

Table 6-119. MMC/SD/SDIO Switching Characteristics – SD Identification Mode⁽¹⁾

| NO. | PARAMETER | | 1.15 V | | 1.0 V | | UNIT |
|---|--------------------|---|--------------------------|--------|--------------------------|--------|------|
| | | | MIN | MAX | MIN | MAX | |
| SD Identification Mode | | | | | | | |
| 1 / (HSSD1/SD1) | $1/t_{c}(clk)$ | Frequency ⁽²⁾ , mmc_x_clk ⁽³⁾ | | 0.4 | | 0.4 | MHz |
| HSSD2/SD2 | $t_{W}(clkH)$ | Typical pulse duration, output clk high | $X^{(4)} \cdot PO^{(5)}$ | | $X^{(4)} \cdot PO^{(5)}$ | | ns |
| HSSD2/SD2 | $t_{W}(clkL)$ | Typical pulse duration, output clk low | $Y^{(6)} \cdot PO^{(5)}$ | | $Y^{(6)} \cdot PO^{(5)}$ | | ns |
| | $t_{dc}(clk)$ | Duty cycle error, output clk | | 125 | | 125 | ns |
| | $t_{j}(clk)$ | Jitter standard deviation ⁽⁷⁾ , output clk | | 200 | | 200 | ps |
| MMC/SD/SDIO Interface 1 (1.8 V IO) | | | | | | | |
| | $t_{c}(clk)$ | Rise time, output clk | | 10 | | 10 | ns |
| | $t_{W}(clkH)$ | Fall time, output clk | | 10 | | 10 | ns |
| | $t_{W}(clkL)$ | Rise time, output data | | 10 | | 10 | ns |
| | $t_{dc}(clk)$ | Fall time, output data | | 10 | | 10 | ns |
| HSSD5/SD5 | $t_{d}(CLKOH-CMD)$ | Delay time, mmc1_clk rising clock edge to mmc1_cmd transition | 6.3 | 2492.7 | 6.3 | 2492.7 | ns |
| MMC/SD/SDIO Interface 1 (3.0 V IO) | | | | | | | |
| | $t_{c}(clk)$ | Rise time, output clk | | 10 | | 0 | ns |
| | $t_{W}(clkH)$ | Fall time, output clk | | 10 | | 0 | ns |
| | $t_{W}(clkL)$ | Rise time, output data | | 10 | | 10 | ns |
| | $t_{dc}(clk)$ | Fall time, output data | | 10 | | 10 | ns |
| HSSD5/SD5 | $t_{d}(CLKOH-CMD)$ | Delay time, mmc1_clk rising clock edge to mmc1_cmd transition | 6.3 | 2492.7 | 6.3 | 2492.7 | ns |
| MMC/SD/SDIO Interface 2 | | | | | | | |
| | $t_{c}(clk)$ | Rise time, output clk | | 10 | | 10 | ns |
| | $t_{W}(clkH)$ | Fall time, output clk | | 10 | | 10 | ns |
| | $t_{W}(clkL)$ | Rise time, output data | | 10 | | 10 | ns |
| | $t_{dc}(clk)$ | Fall time, output data | | 10 | | 10 | ns |
| HSSD5/SD5 | $t_{d}(CLKOH-CMD)$ | Delay time, mmc2_clk rising clock edge to mmc2_cmd transition | 6.3 | 2492.7 | 6.3 | 2492.7 | ns |
| MMC/SD/SDIO Interface 3 | | | | | | | |
| | $t_{c}(clk)$ | Rise time, output clk | | 10 | | 10 | ns |

(1) Corresponding figures showing timing parameters are common with other interface modes (see SD and HS SD modes).

(2) Related with the output clk maximum and minimum frequencies programmable in I/F module.

(3) In mmc_x_clk, 'x' is equal to 1, 2, or 3.

(4) The X parameter is defined as shown in [Table 6-120](#).

(5) PO = output clk period in ns.

(6) The Y parameter is defined as shown in [Table 6-121](#).

(7) The jitter probability density can be approximated by a Gaussian function.

Table 6-119. MMC/SD/SDIO Switching Characteristics – SD Identification Mode (continued)

| NO. | PARAMETER | | 1.15 V | | 1.0 V | | UNIT |
|-----------|-------------------------|---|--------|--------|-------|--------|------|
| | | | MIN | MAX | MIN | MAX | |
| | $t_{W(\text{clkH})}$ | Fall time, output clk | | 10 | | 10 | ns |
| | $t_{W(\text{clkL})}$ | Rise time, output data | | 10 | | 10 | ns |
| | $t_{dc(\text{clk})}$ | Fall time, output data | | 10 | | 10 | ns |
| HSSD5/SD5 | $t_d(\text{CLKOH-CMD})$ | Delay time, mmc3_clk rising clock edge to mmc3_cmd transition | 6.3 | 2492.7 | 6.3 | 2492.7 | ns |

Table 6-120. X Parameter

| | |
|-----------|---|
| CLKD | X |
| 1 or Even | 0.5 |
| Odd | $(\text{trunk}[\text{CLKD}/2]+1)/\text{CLKD}$ |

Table 6-121. Y Parameter

| | |
|-----------|---|
| CLKD | Y |
| 1 or Even | 0.5 |
| Odd | $(\text{trunk}[\text{CLKD}/2])/\text{CLKD}$ |

For details about clock division factor CLKD, see the *OMAP35x Technical Reference Manual (TRM)* [literature number [SPRUF98](#)].

6.7.1.2 MMC/SD/SDIO in High-Speed MMC Mode

[Table 6-123](#) and [Table 6-124](#) assume testing over the recommended operating conditions and electrical characteristic conditions (see [Figure 6-63](#) and [Figure 6-64](#)).

Table 6-122. MMC/SD/SDIO Timing Conditions – High-Speed MMC Mode

| TIMING CONDITION PARAMETER | | VALUE | UNIT |
|----------------------------|-------------------------|-------|------|
| High-Speed MMC Mode | | | |
| Input Conditions | | | |
| t_R | Input signal rise time | 3 | ns |
| t_F | Input signal fall time | 3 | ns |
| Output Conditions | | | |
| C_{LOAD} | Output load capacitance | 30 | pF |

Table 6-123. MMC/SD/SDIO Timing Requirements – High-Speed MMC Mode⁽¹⁾⁽²⁾⁽³⁾⁽⁴⁾

| NO. | PARAMETER | | 1.15 V | | 1.0 V | | UNIT |
|---|-------------------------------|---|--------|-----|-------|-----|------|
| | | | MIN | MAX | MIN | MAX | |
| High-Speed MMC Mode | | | | | | | |
| MMC/SD/SDIO Interface 1 (1.8 V IO) | | | | | | | |
| MMC3 | $t_{su}(\text{CMDV-CLKIH})$ | Setup time, mmc1_cmd valid before mmc1_clk rising clock edge | 5.6 | | 26 | | ns |
| MMC4 | $t_{su}(\text{CLKIH-CMDIV})$ | Hold time, mmc1_cmd valid after mmc1_clk rising clock edge | 2.3 | | 1.9 | | ns |
| MMC7 | $t_{su}(\text{DATxV-CLKIH})$ | Setup time, mmc1_datx valid before mmc1_clk rising clock edge | 5.6 | | 26 | | ns |
| MMC8 | $t_{su}(\text{CLKIH-DATxIV})$ | Hold time, mmc1_datx valid after mmc1_clk rising clock edge | 2.3 | | 1.9 | | ns |

- (1) Timing parameters are referred to output clock specified in [Table 6-124](#).
- (2) The timing requirements are assured for the cycle jitter and duty cycle error conditions specified in [Table 6-124](#).
- (3) Corresponding figures showing timing parameters are common with Standard MMC mode (See [Figure 6-63](#) and [Figure 6-64](#))
- (4) In datx, x is equal to 1, 2, 3, 4, 5, 6, or 7.

Table 6-123. MMC/SD/SDIO Timing Requirements – High-Speed MMC Mode (continued)

| NO. | PARAMETER | | 1.15 V | | 1.0 V | | UNIT |
|---|------------------------|---|--------|-----|-------|-----|------|
| | | | MIN | MAX | MIN | MAX | |
| MMC/SD/SDIO Interface 1 (3.0 V IO) | | | | | | | |
| MMC3 | $t_{su}(CMDV-CLKIH)$ | Setup time, mmc1_cmd valid before mmc1_clk rising clock edge | 5.6 | | 26 | | ns |
| MMC4 | $t_{su}(CLKIH-CMDIV)$ | Hold time, mmc1_cmd valid after mmc1_clk rising clock edge | 2.3 | | 1.9 | | ns |
| MMC7 | $t_{su}(DATxV-CLKIH)$ | Setup time, mmc1_datx valid before mmc1_clk rising clock edge | 5.6 | | 26 | | ns |
| MMC8 | $t_{su}(CLKIH-DATxIV)$ | Hold time, mmc1_datx valid after mmc1_clk rising clock edge | 2.3 | | 1.9 | | ns |
| MMC/SD/SDIO Interface 2 | | | | | | | |
| MMC3 | $t_{su}(CMDV-CLKIH)$ | Setup time, mmc2_cmd valid before mmc2_clk rising clock edge | 5.6 | | 26 | | ns |
| MMC4 | $t_{su}(CLKIH-CMDIV)$ | Hold time, mmc2_cmd valid after mmc2_clk rising clock edge | 2.3 | | 1.9 | | ns |
| MMC7 | $t_{su}(DATxV-CLKIH)$ | Setup time, mmc2_datx valid before mmc2_clk rising clock edge | 5.6 | | 26 | | ns |
| MMC8 | $t_{su}(CLKIH-DATxIV)$ | Hold time, mmc2_datx valid after mmc2_clk rising clock edge | 2.3 | | 1.9 | | ns |
| MMC/SD/SDIO Interface 3 | | | | | | | |
| MMC3 | $t_{su}(CMDV-CLKIH)$ | Setup time, mmc3_cmd valid before mmc3_clk rising clock edge | 5.6 | | 26 | | ns |
| MMC4 | $t_{su}(CLKIH-CMDIV)$ | Hold time, mmc3_cmd valid after mmc3_clk rising clock edge | 2.3 | | 1.9 | | ns |
| MMC7 | $t_{su}(DATxV-CLKIH)$ | Setup time, mmc3_datx valid before mmc3_clk rising clock edge | 5.6 | | 26 | | ns |
| MMC8 | $t_{su}(CLKIH-DATxIV)$ | Hold time, mmc3_datx valid after mmc3_clk rising clock edge | 2.3 | | 1.9 | | ns |

Table 6-124. MMC/SD/SDIO Switching Characteristics – High-Speed MMC Mode⁽¹⁾

| N O. | PARAMETER | | 1.15 V | | 1.0 V | | UNIT |
|---|--------------------|---|--------------------------|--------|--------------------------|--------|------|
| | | | MIN | MAX | MIN | MAX | |
| High-Speed MMC Mode | | | | | | | |
| 1/MMC 1 | $1/t_{c}(clk)$ | Frequency ⁽²⁾ , mmc _x _clk ⁽³⁾ | | 48 | | 24 | MHz |
| MMC2 | $t_{W}(clkH)$ | Typical pulse duration, output clk high | $X^{(4)} \cdot PO^{(5)}$ | | $X^{(4)} \cdot PO^{(5)}$ | | ns |
| MMC2 | $t_{W}(clkL)$ | Typical pulse duration, output clk low | $Y^{(6)} \cdot PO^{(5)}$ | | $Y^{(6)} \cdot PO^{(5)}$ | | ns |
| | $t_{dc}(clk)$ | Duty cycle error, output clk | | 1041.7 | | 2083.3 | ps |
| | $t_{j}(clk)$ | Jitter standard deviation ⁽⁷⁾ , output clk | | 200 | | 200 | ps |
| MMC/SD/SDIO Interface 1 (1.8 V IO) | | | | | | | |
| | $t_{c}(clk)$ | Rise time, output clk | | 3 | | 3 | ns |
| | $t_{W}(clkH)$ | Fall time, output clk | | 3 | | 3 | ns |
| | $t_{W}(clkL)$ | Rise time, output data | | 3 | | 3 | ns |
| | $t_{dc}(clk)$ | Fall time, output data | | 3 | | 3 | ns |
| MMC5 | $t_{d}(CLKOH-CMD)$ | Delay time, mmc1_clk rising clock edge to mmc1_cmd transition | 3.7 | 14.1 | 4.1 | 34.5 | ns |

(1) In datx, x is equal to 1, 2, 3, 4, 5, 6, or 7.

(2) Related with the output clk maximum and minimum frequencies programmable in I/F module.

(3) In mmc_x_clk, 'x' is equal to 1, 2, or 3.

(4) The X parameter is defined as shown in Table 6-125.

(5) PO = output clk period in ns.

(6) The Y parameter is defined as shown in Table 6-126.

(7) The jitter probability density can be approximated by a Gaussian function.

Table 6-124. MMC/SD/SDIO Switching Characteristics – High-Speed MMC Mode (continued)

| N O. | PARAMETER | | 1.15 V | | 1.0 V | | UNIT |
|---|---------------------|--|--------|------|-------|------|------|
| | | | MIN | MAX | MIN | MAX | |
| MMC6 | $t_{d(CLKOH-DATx)}$ | Delay time, mmc1_clk rising clock edge to mmc1_datx transition | 3.7 | 14.1 | 4.1 | 34.5 | ns |
| MMC/SD/SDIO Interface 1 (3.0 V IO) | | | | | | | |
| | $t_{c(clk)}$ | Rise time, output clk | | 3 | | 3 | ns |
| | $t_{W(clkH)}$ | Fall time, output clk | | 3 | | 3 | ns |
| | $t_{W(clkL)}$ | Rise time, output data | | 3 | | 3 | ns |
| | $t_{dc(clk)}$ | Fall time, output data | | 3 | | 3 | ns |
| MMC5 | $t_{d(CLKOH-CMD)}$ | Delay time, mmc1_clk rising clock edge to mmc1_cmd transition | 3.7 | 14.1 | 4.1 | 34.5 | ns |
| MMC6 | $t_{d(CLKOH-DATx)}$ | Delay time, mmc1_clk rising clock edge to mmc1_datx transition | 3.7 | 14.1 | 4.1 | 34.5 | ns |
| MMC/SD/SDIO Interface 2 | | | | | | | |
| | $t_{c(clk)}$ | Rise time, output clk | | 3 | | 3 | ns |
| | $t_{W(clkH)}$ | Fall time, output clk | | 3 | | 3 | ns |
| | $t_{W(clkL)}$ | Rise time, output data | | 3 | | 3 | ns |
| | $t_{dc(clk)}$ | Fall time, output data | | 3 | | 3 | ns |
| MMC5 | $t_{d(CLKOH-CMD)}$ | Delay time, mmc2_clk rising clock edge to mmc2_cmd transition | 3.7 | 14.1 | 4.1 | 34.5 | ns |
| MMC6 | $t_{d(CLKOH-DATx)}$ | Delay time, mmc2_clk rising clock edge to mmc2_datx transition | 3.7 | 16.5 | 4.1 | 36.9 | ns |
| MMC/SD/SDIO Interface 3 | | | | | | | |
| | $t_{c(clk)}$ | Rise time, output clk | | 3 | | 3 | ns |
| | $t_{W(clkH)}$ | Fall time, output clk | | 3 | | 3 | ns |
| | $t_{W(clkL)}$ | Rise time, output data | | 3 | | 3 | ns |
| | $t_{dc(clk)}$ | Fall time, output data | | 3 | | 3 | ns |
| MMC5 | $t_{d(CLKOH-CMD)}$ | Delay time, mmc3_clk rising clock edge to mmc3_cmd transition | 3.7 | 14.1 | 4.1 | 34.5 | ns |
| MMC6 | $t_{d(CLKOH-DATx)}$ | Delay time, mmc3_clk rising clock edge to mmc3_datx transition | 3.7 | 14.1 | 4.1 | 34.5 | ns |

Table 6-125. X Parameter

| CLKD | X |
|-----------|---|
| 1 or Even | 0.5 |
| Odd | $(\text{trunk}[\text{CLKD}/2]+1)/\text{CLKD}$ |

Table 6-126. Y Parameter

| CLKD | Y |
|-----------|--|
| 1 or Even | 0.5 |
| Odd | $(\text{trunk}[\text{CLKD}/2])/ \text{CLKD}$ |

For details about clock division factor CLKD, see the *OMAP35x Technical Reference Manual (TRM)* [literature number [SPRUF98](#)].

6.7.1.3 MMC/SD/SDIO in Standard MMC Mode and MMC Identification Mode

[Table 6-128](#) and [Table 6-129](#) assume testing over the recommended operating conditions and electrical characteristic conditions.

Table 6-127. MMC/SD/SDIO Timing Conditions – Standard MMC Mode and MMC Identification Mode

| TIMING CONDITION PARAMETER | | VALUE | UNIT |
|--|-------------------------|-------|------|
| Standard MMC Mode and MMC Identification Mode | | | |
| Input Conditions | | | |
| t_R | Input signal rise time | 10 | ns |
| t_F | Input signal fall time | 10 | ns |
| Output Conditions | | | |
| C_{LOAD} | Output load capacitance | 30 | pF |

Table 6-128. MMC/SD/SDIO Timing Requirements – Standard MMC Mode and MMC Identification Mode⁽¹⁾⁽²⁾

| NO. | PARAMETER | | 1.15 V | | 1.0 V | | UNIT |
|--|------------------------|---|--------|-----|-------|-----|------|
| | | | MIN | MAX | MIN | MAX | |
| Standard MMC Mode and MMC Identification Mode | | | | | | | |
| MMC/SD/SDIO Interface 1 (1.8 V IO) | | | | | | | |
| MMC3 | $t_{su}(CMDV-CLKIH)$ | Setup time, mmc1_cmd valid before mmc1_clk rising clock edge | 13.6 | | 65.7 | | ns |
| MMC4 | $t_{su}(CLKIH-CMDIV)$ | Hold time, mmc1_cmd valid after mmc1_clk rising clock edge | 8.9 | | 8.9 | | ns |
| MMC7 | $t_{su}(DATxV-CLKIH)$ | Setup time, mmc1_datx valid before mmc1_clk rising clock edge | 13.6 | | 65.7 | | ns |
| MMC8 | $t_{su}(CLKIH-DATxIV)$ | Hold time, mmc1_datx valid after mmc1_clk rising clock edge | 8.9 | | 8.9 | | ns |
| MMC/SD/SDIO Interface 1 (3.0 V IO) | | | | | | | |
| MMC3 | $t_{su}(CMDV-CLKIH)$ | Setup time, mmc1_cmd valid before mmc1_clk rising clock edge | 13.6 | | 65.7 | | ns |
| MMC4 | $t_{su}(CLKIH-CMDIV)$ | Hold time, mmc1_cmd valid after mmc1_clk rising clock edge | 8.9 | | 8.9 | | ns |
| MMC7 | $t_{su}(DATxV-CLKIH)$ | Setup time, mmc1_datx valid before mmc1_clk rising clock edge | 13.6 | | 65.7 | | ns |
| MMC8 | $t_{su}(CLKIH-DATxIV)$ | Hold time, mmc1_datx valid after mmc1_clk rising clock edge | 8.9 | | 8.9 | | ns |
| MMC/SD/SDIO Interface 2 | | | | | | | |
| MMC3 | $t_{su}(CMDV-CLKIH)$ | Setup time, mmc2_cmd valid before mmc2_clk rising clock edge | 13.6 | | 65.7 | | ns |
| MMC4 | $t_{su}(CLKIH-CMDIV)$ | Hold time, mmc2_cmd valid after mmc2_clk rising clock edge | 8.9 | | 8.9 | | ns |
| MMC7 | $t_{su}(DATxV-CLKIH)$ | Setup time, mmc2_datx valid before mmc2_clk rising clock edge | 13.6 | | 65.7 | | ns |
| MMC8 | $t_{su}(CLKIH-DATxIV)$ | Hold time, mmc2_datx valid after mmc2_clk rising clock edge | 8.9 | | 8.9 | | ns |
| MMC/SD/SDIO Interface 3 | | | | | | | |
| MMC3 | $t_{su}(CMDV-CLKIH)$ | Setup time, mmc3_cmd valid before mmc3_clk rising clock edge | 13.6 | | 65.7 | | ns |
| MMC4 | $t_{su}(CLKIH-CMDIV)$ | Hold time, mmc3_cmd valid after mmc3_clk rising clock edge | 8.9 | | 8.9 | | ns |
| MMC7 | $t_{su}(DATxV-CLKIH)$ | Setup time, mmc3_datx valid before mmc3_clk rising clock edge | 13.6 | | 65.7 | | ns |
| MMC8 | $t_{su}(CLKIH-DATxIV)$ | Hold time, mmc3_datx valid after mmc3_clk rising clock edge | 8.9 | | 8.9 | | ns |

(1) Timing parameters are referred to output clock specified in [Table 6-129](#).

(2) The timing requirements are assured for the cycle jitter and duty cycle error conditions specified in [Table 6-129](#).

Table 6-129. MMC/SD/SDIO Switching Characteristics – Standard MMC Mode and MMC Identification Mode

| NO. | PARAMETER | | 1.15 V | | 1.0 V | | UNIT |
|--------------------------------|----------------|---|--------------------------|-----|--------------------------|-----|------|
| | | | MIN | MAX | MIN | MAX | |
| MMC Identification Mode | | | | | | | |
| 1/MMC1 | $1/t_{c}(clk)$ | Frequency ⁽¹⁾ , mmc _x _clk ⁽²⁾ | | 0.4 | | 0.4 | MHz |
| MMC2 | $t_{W}(clkH)$ | Typical pulse duration, output clk high | $X^{(3)} \cdot PO^{(4)}$ | | $X^{(3)} \cdot PO^{(4)}$ | | ns |

(1) Related with the output clk maximum and minimum frequencies programmable in I/F module.

(2) In mmc_x_clk, 'x' is equal to 1, 2, or 3.

(3) The X parameter is defined as shown in [Table 6-130](#).

(4) PO = output clk period in ns.

Table 6-129. MMC/SD/SDIO Switching Characteristics – Standard MMC Mode and MMC Identification Mode (continued)

| NO. | PARAMETER | | 1.15 V | | 1.0 V | | UNIT |
|---|----------------------------|--|--------------------------|--------|--------------------------|--------|------|
| | | | MIN | MAX | MIN | MAX | |
| MMC2 | $t_{W(\text{clkL})}$ | Typical pulse duration, output clk low | $Y \cdot PO^{(4)}$ | | $Y \cdot PO^{(4)}$ | | ns |
| | $t_{dc(\text{clk})}$ | Duty cycle error, output clk | | 125 | | 125 | ns |
| | $t_{j(\text{clk})}$ | Jitter standard deviation ⁽⁵⁾ , output clk | | 200 | | 200 | ps |
| Standard MMC Mode | | | | | | | |
| 1/MMC 1 | $1/t_{c(\text{clk})}$ | Frequency ⁽¹⁾ , mmc_x_clk ⁽²⁾ | | 19.2 | | 9.6 | MHz |
| MMC2 | $t_{W(\text{clkH})}$ | Typical pulse duration, output clk high | $X^{(3)} \cdot PO^{(4)}$ | | $X^{(3)} \cdot PO^{(4)}$ | | ns |
| MMC2 | $t_{W(\text{clkL})}$ | Typical pulse duration, output clk low | $Y \cdot PO^{(4)}$ | | $Y \cdot PO^{(4)}$ | | ns |
| | $t_{dc(\text{clk})}$ | Duty cycle error, output clk | | 2604.2 | | 5208.3 | ps |
| | $t_{j(\text{clk})}$ | Jitter standard deviation ⁽⁵⁾ , output clk | | 200 | | 200 | ps |
| MMC/SD/SDIO Interface 1 (1.8 V IO) | | | | | | | |
| | $t_{c(\text{clk})}$ | Rise time, output clk | | 10 | | 10 | ns |
| | $t_{W(\text{clkH})}$ | Fall time, output clk | | 10 | | 10 | ns |
| | $t_{W(\text{clkL})}$ | Rise time, output data | | 10 | | 10 | ns |
| | $t_{dc(\text{clk})}$ | Fall time, output data | | 10 | | 10 | ns |
| MMC5 | $t_{d(\text{CLKOH-CMD})}$ | Delay time, mmc1_clk rising clock edge to mmc1_cmd transition | 4.3 | 47.8 | 4.3 | 99.9 | ns |
| MMC6 | $t_{d(\text{CLKOH-DATx})}$ | Delay time, mmc1_clk rising clock edge to mmc1_datx transition | 4.3 | 47.8 | 4.3 | 99.9 | ns |
| MMC/SD/SDIO Interface 1 (3.0 V IO) | | | | | | | |
| | $t_{c(\text{clk})}$ | Rise time, output clk | | 10 | | 10 | ns |
| | $t_{W(\text{clkH})}$ | Fall time, output clk | | 10 | | 10 | ns |
| | $t_{W(\text{clkL})}$ | Rise time, output data | | 10 | | 10 | ns |
| | $t_{dc(\text{clk})}$ | Fall time, output data | | 10 | | 10 | ns |
| MMC5 | $t_{d(\text{CLKOH-CMD})}$ | Delay time, mmc1_clk rising clock edge to mmc1_cmd transition | 4.3 | 47.8 | 4.3 | 99.9 | ns |
| MMC6 | $t_{d(\text{CLKOH-DATx})}$ | Delay time, mmc1_clk rising clock edge to mmc1_datx transition | 4.3 | 47.8 | 4.3 | 99.9 | ns |
| MMC/SD/SDIO Interface 2 | | | | | | | |
| | $t_{c(\text{clk})}$ | Rise time, output clk | | 10 | | 10 | ns |
| | $t_{W(\text{clkH})}$ | Fall time, output clk | | 10 | | 10 | ns |
| | $t_{W(\text{clkL})}$ | Rise time, output data | | 10 | | 10 | ns |
| | $t_{dc(\text{clk})}$ | Fall time, output data | | 10 | | 10 | ns |
| MMC5 | $t_{d(\text{CLKOH-CMD})}$ | Delay time, mmc2_clk rising clock edge to mmc2_cmd transition | 4.3 | 47.8 | 4.3 | 99.9 | ns |
| MMC6 | $t_{d(\text{CLKOH-DATx})}$ | Delay time, mmc2_clk rising clock edge to mmc2_datx transition | 4.3 | 47.8 | 4.3 | 99.9 | ns |
| MMC/SD/SDIO Interface 3 | | | | | | | |
| | $t_{c(\text{clk})}$ | Rise time, output clk | | 10 | | 10 | ns |
| | $t_{W(\text{clkH})}$ | Fall time, output clk | | 10 | | 10 | ns |
| | $t_{W(\text{clkL})}$ | Rise time, output data | | 10 | | 10 | ns |
| | $t_{dc(\text{clk})}$ | Fall time, output data | | 10 | | 10 | ns |
| MMC5 | $t_{d(\text{CLKOH-CMD})}$ | Delay time, mmc3_clk rising clock edge to mmc3_cmd transition | 4.3 | 47.8 | 4.3 | 99.9 | ns |
| MMC6 | $t_{d(\text{CLKOH-DATx})}$ | Delay time, mmc3_clk rising clock edge to mmc3_datx transition | 4.3 | 47.8 | 4.3 | 99.9 | ns |

(5) The jitter probability density can be approximated by a Gaussian function.

Table 6-130. X Parameter

| | |
|-------------|---|
| CLKD | X |
| 1 or Even | 0.5 |
| Odd | $(\text{trunk}[\text{CLKD}/2]+1)/\text{CLKD}$ |

Table 6-131. Y Parameter

| | |
|-------------|--|
| CLKD | Y |
| 1 or Even | 0.5 |
| Odd | $(\text{trunk}[\text{CLKD}/2])/ \text{CLKD}$ |

For details about clock division factor CLKD, see the *OMAP35x Technical Reference Manual (TRM)* [literature number [SPRUF98](#)].

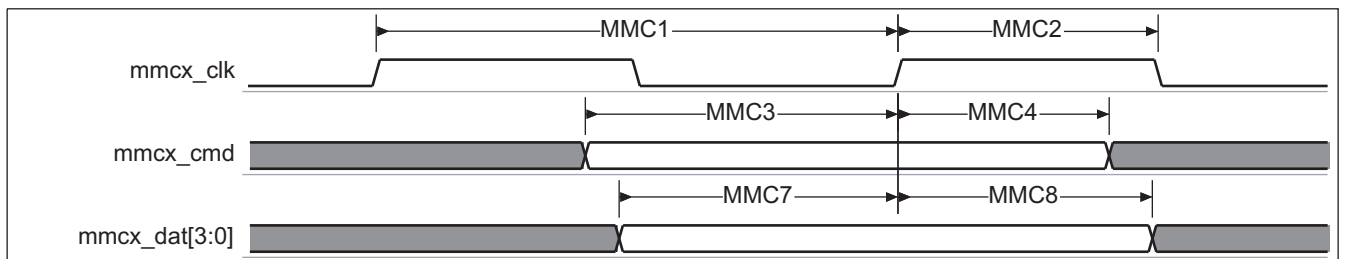

030-104

In mmc_x, x is equal to 1, 2, or 3.

Figure 6-63. MMC/SD/SDIO – High-Speed and Standard MMC Modes – Data/Command Receive

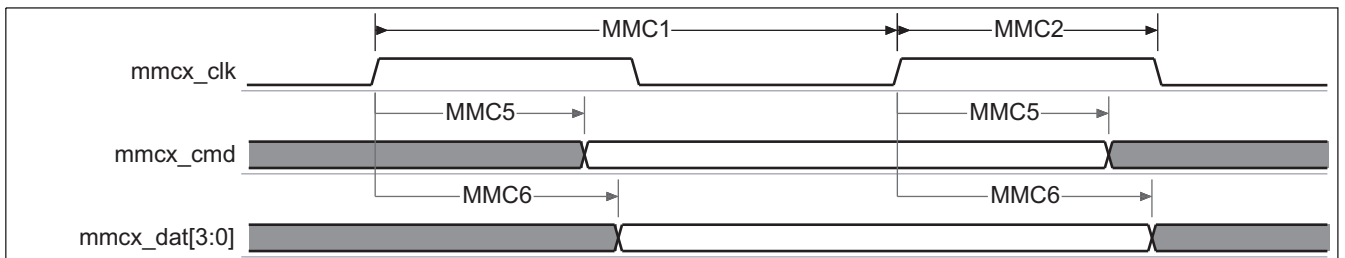

030-105

In mmc_x, x is equal to 1, 2, or 3.

Figure 6-64. MMC/SD/SDIO – High-Speed and Standard MMC Modes – Data/Command Transmit

6.7.1.4 MMC/SD/SDIO in High-Speed SD Mode

Table 6-133 and Table 6-134 assume testing over the recommended operating conditions and electrical characteristic conditions.

Table 6-132. MMC/SD/SDIO Timing Conditions – High-Speed SD Mode

| TIMING CONDITION PARAMETER | | VALUE | UNIT |
|----------------------------|-------------------------|-------|------|
| High-Speed SD Mode | | | |
| Input Conditions | | | |
| t _R | Input signal rise time | 3 | ns |
| t _F | Input signal fall time | 3 | ns |
| Output Conditions | | | |
| C _{LOAD} | Output load capacitance | 40 | pF |

Table 6-133. MMC/SD/SDIO Timing Requirements – High-Speed SD Mode⁽¹⁾⁽²⁾⁽³⁾

| NO. | PARAMETER | | 1.15 V | | 1.0 V | | UNIT |
|---|------------------------|---|--------|-----|-------|-----|------|
| | | | MIN | MAX | MIN | MAX | |
| High-Speed SD Mode | | | | | | | |
| MMC/SD/SDIO Interface 1 (1.8 V IO) | | | | | | | |
| HSSD3 | $t_{su(CMDV-CLKIH)}$ | Setup time, mmc1_cmd valid before mmc1_clk rising clock edge | 5.6 | | 26 | | ns |
| HSSD4 | $t_{su(CLKIH-CMDIV)}$ | Hold time, mmc1_cmd valid after mmc1_clk rising clock edge | 2.3 | | 1.9 | | ns |
| HSSD7 | $t_{su(DATxV-CLKIH)}$ | Setup time, mmc1_datx valid before mmc1_clk rising clock edge | 5.6 | | 26 | | ns |
| HSSD8 | $t_{su(CLKIH-DATxIV)}$ | Hold time, mmc1_datx valid after mmc1_clk rising clock edge | 2.3 | | 1.9 | | ns |
| MMC/SD/SDIO Interface 1 (3.0 V IO) | | | | | | | |
| HSSD3 | $t_{su(CMDV-CLKIH)}$ | Setup time, mmc1_cmd valid before mmc1_clk rising clock edge | 5.6 | | 26 | | ns |
| HSSD4 | $t_{su(CLKIH-CMDIV)}$ | Hold time, mmc1_cmd valid after mmc1_clk rising clock edge | 2.3 | | 1.9 | | ns |
| HSSD7 | $t_{su(DATxV-CLKIH)}$ | Setup time, mmc1_datx valid before mmc1_clk rising clock edge | 5.6 | | 26 | | ns |
| HSSD8 | $t_{su(CLKIH-DATxIV)}$ | Hold time, mmc1_datx valid after mmc1_clk rising clock edge | 2.3 | | 1.9 | | ns |
| MMC/SD/SDIO Interface 2 | | | | | | | |
| HSSD3 | $t_{su(CMDV-CLKIH)}$ | Setup time, mmc2_cmd valid before mmc2_clk rising clock edge | 5.6 | | 26 | | ns |
| HSSD4 | $t_{su(CLKIH-CMDIV)}$ | Hold time, mmc2_cmd valid after mmc2_clk rising clock edge | 2.3 | | 1.9 | | ns |
| HSSD7 | $t_{su(DATxV-CLKIH)}$ | Setup time, mmc2_datx valid before mmc2_clk rising clock edge | 5.6 | | 26 | | ns |
| HSSD8 | $t_{su(CLKIH-DATxIV)}$ | Hold time, mmc2_datx valid after mmc2_clk rising clock edge | 2.3 | | 1.9 | | ns |
| MMC/SD/SDIO Interface 3 | | | | | | | |
| HSSD3 | $t_{su(CMDV-CLKIH)}$ | Setup time, mmc3_cmd valid before mmc3_clk rising clock edge | 5.6 | | 26 | | ns |
| HSSD4 | $t_{su(CLKIH-CMDIV)}$ | Hold time, mmc3_cmd valid after mmc3_clk rising clock edge | 2.3 | | 1.9 | | ns |
| HSSD7 | $t_{su(DATxV-CLKIH)}$ | Setup time, mmc3_datx valid before mmc3_clk rising clock edge | 5.6 | | 26 | | ns |
| HSSD8 | $t_{su(CLKIH-DATxIV)}$ | Hold time, mmc3_datx valid after mmc3_clk rising clock edge | 2.3 | | 1.9 | | ns |

(1) Timing Parameters are referred to output clock specified in [Table 6-134](#).

(2) The timing requirements are assured for the cycle jitter and duty cycle error conditions specified in [Table 6-134](#).

(3) In datx, x is equal to 1, 2, 3, 4, 5, 6, or 7.

Table 6-134. MMC/SD/SDIO Switching Characteristics – High-Speed SD Mode

| NO. | PARAMETER | | 1.15 V | | 1.0 V | | UNIT |
|---------------------------|----------------|---|--------------------------|-----|--------------------------|-----|------|
| | | | MIN | MAX | MIN | MAX | |
| High-Speed SD Mode | | | | | | | |
| 1/HSSD1 | $1/t_{c(clk)}$ | Frequency ⁽¹⁾ , mmc _x _clk ⁽²⁾ | | 48 | | 24 | ns |
| HSSD2 | $t_{W(clkH)}$ | Typical pulse duration, output clk high | $X^{(3)} \cdot PO^{(4)}$ | | $X^{(3)} \cdot PO^{(4)}$ | | ns |

(1) Related with the output clk maximum and minimum frequencies programmable in I/F module.

(2) In mmc_x_clk, 'x' is equal to 1, 2, or 3.

(3) The X parameter is defined as shown in [Table 6-135](#).

(4) PO = output clk period in ns.

Table 6-134. MMC/SD/SDIO Switching Characteristics – High-Speed SD Mode (continued)

| NO. | PARAMETER | | 1.15 V | | 1.0 V | | UNIT |
|---|----------------------------|--|--------------------------|--------|--------------------------|--------|------|
| | | | MIN | MAX | MIN | MAX | |
| HSSD2 | $t_{W(\text{clkL})}$ | Typical pulse duration, output clk low | $Y^{(5)} \cdot PO^{(4)}$ | | $Y^{(5)} \cdot PO^{(4)}$ | | ns |
| | $t_{dc(\text{clk})}$ | Duty cycle error, output clk | | 1041.7 | | 2083.3 | ps |
| | $t_j(\text{clk})$ | Jitter standard deviation ⁽⁶⁾ , output clk | | 200 | | 200 | ps |
| MMC/SD/SDIO Interface 1 (1.8 V IO) | | | | | | | |
| | $t_{c(\text{clk})}$ | Rise time, output clk | | 3 | | 3 | ns |
| | $t_{W(\text{clkH})}$ | Fall time, output clk | | 3 | | 3 | ns |
| | $t_{W(\text{clkL})}$ | Rise time, output data | | 3 | | 3 | ns |
| | $t_{dc(\text{clk})}$ | Fall time, output data | | 3 | | 3 | ns |
| HSSD5 | $t_{d(\text{CLKOH-CMD})}$ | Delay time, mmc1_clk rising clock edge to mmc1_cmd transition | 3.7 | 14.1 | 4.1 | 34.5 | ns |
| HSSD6 | $t_{d(\text{CLKOH-DATx})}$ | Delay time, mmc1_clk rising clock edge to mmc1_datx transition | 3.7 | 14.1 | 4.1 | 34.5 | ns |
| MMC/SD/SDIO Interface 1 (3.0 V IO) | | | | | | | |
| | $t_{c(\text{clk})}$ | Rise time, output clk | | 3 | | 3 | ns |
| | $t_{W(\text{clkH})}$ | Fall time, output clk | | 3 | | 3 | ns |
| | $t_{W(\text{clkL})}$ | Rise time, output data | | 3 | | 3 | ns |
| | $t_{dc(\text{clk})}$ | Fall time, output data | | 3 | | 3 | ns |
| HSSD5 | $t_{d(\text{CLKOH-CMD})}$ | Delay time, mmc1_clk rising clock edge to mmc1_cmd transition | 3.7 | 14.1 | 4.1 | 34.5 | ns |
| HSSD6 | $t_{d(\text{CLKOH-DATx})}$ | Delay time, mmc1_clk rising clock edge to mmc1_datx transition | 3.7 | 14.1 | 4.1 | 34.5 | ns |
| MMC/SD/SDIO Interface 2 | | | | | | | |
| | $t_{c(\text{clk})}$ | Rise time, output clk | | 3 | | 3 | ns |
| | $t_{W(\text{clkH})}$ | Fall time, output clk | | 3 | | 3 | ns |
| | $t_{W(\text{clkL})}$ | Rise time, output data | | 3 | | 3 | ns |
| | $t_{dc(\text{clk})}$ | Fall time, output data | | 3 | | 3 | ns |
| HSSD5 | $t_{d(\text{CLKOH-CMD})}$ | Delay time, mmc2_clk rising clock edge to mmc2_cmd transition | 3.7 | 14.1 | 4.1 | 34.5 | ns |
| HSSD6 | $t_{d(\text{CLKOH-DATx})}$ | Delay time, mmc2_clk rising clock edge to mmc2_datx transition | 3.7 | 14.1 | 4.1 | 34.5 | ns |
| MMC/SD/SDIO Interface 3 | | | | | | | |
| | $t_{c(\text{clk})}$ | Rise time, output clk | | 3 | | 3 | ns |
| | $t_{W(\text{clkH})}$ | Fall time, output clk | | 3 | | 3 | ns |
| | $t_{W(\text{clkL})}$ | Rise time, output data | | 3 | | 3 | ns |
| | $t_{dc(\text{clk})}$ | Fall time, output data | | 3 | | 3 | ns |
| HSSD5 | $t_{d(\text{CLKOH-CMD})}$ | Delay time, mmc3_clk rising clock edge to mmc3_cmd transition | 3.7 | 14.1 | 4.1 | 34.5 | ns |
| HSSD6 | $t_{d(\text{CLKOH-DATx})}$ | Delay time, mmc3_clk rising clock edge to mmc3_datx transition | 3.7 | 14.1 | 4.1 | 34.5 | ns |

(5) The Y parameter is defined as shown in Table 6-136.

(6) The jitter probability density can be approximated by a Gaussian function.

Table 6-135. X Parameters

| CLKD | X |
|-----------|---|
| 1 or Even | 0.5 |
| Odd | $(\text{trunk}[\text{CLKD}/2]+1)/\text{CLKD}$ |

Table 6-136. Y Parameters

| CLKD | Y |
|-----------|----------------------|
| 1 or Even | 0.5 |
| Odd | (trunk[CLKD/2])/CLKD |

For details about clock division factor CLKD, see the *OMAP35x Technical Reference Manual (TRM)* [literature number [SPRUF98](#)].

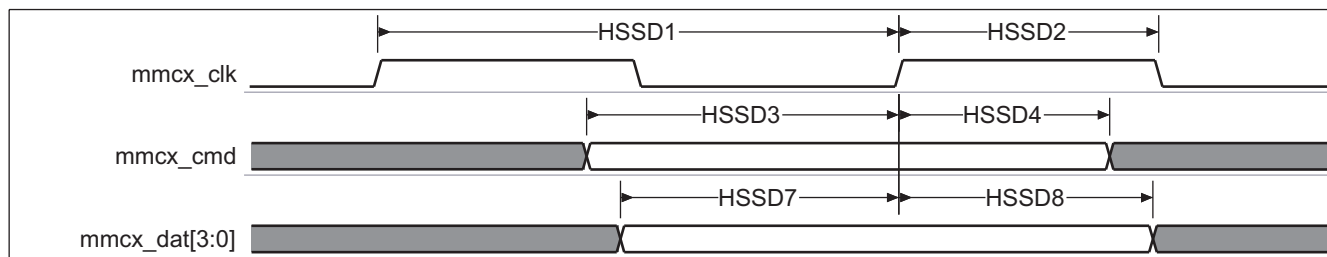

030-106

In mmc_x, x is equal to 1, 2, or 3.

Figure 6-65. MMC/SD/SDIO – High-Speed SD Mode – Data/Command Receive



030-107

In mmc_x, x is equal to 1, 2, or 3.

Figure 6-66. MMC/SD/SDIO – High-Speed SD Mode – Data/Command Transmit

6.7.1.5 MMC/SD/SDIO in Standard SD Mode

Table 6-138 and Table 6-139 assume testing over the recommended operating conditions and electrical characteristic conditions (see Figure 6-67).

Table 6-137. MMC/SD/SDIO Timing Conditions – Standard SD Mode

| TIMING CONDITION PARAMETER | | VALUE | UNIT |
|----------------------------|-------------------------|-------|------|
| Standard SD Mode | | | |
| Input Conditions | | | |
| t_R | Input signal rise time | 10 | ns |
| t_F | Input signal fall time | 10 | ns |
| Output Conditions | | | |
| C_{LOAD} | Output load capacitance | 40 | pF |

Table 6-138. MMC/SD/SDIO Timing Requirements – Standard SD Mode⁽¹⁾⁽²⁾⁽³⁾

| NO. | PARAMETER | | 1.15 V | | 1.0 V | | UNIT |
|---|------------------------|---|--------|-----|-------|-----|------|
| | | | MIN | MAX | MIN | MAX | |
| Standard SD Mode | | | | | | | |
| MMC/SD/SDIO Interface 1 (1.8 V IO) | | | | | | | |
| SD3 | $t_{su}(CMDV-CLKIH)$ | Setup time, mmc1_cmd valid before mmc1_clk rising clock edge | 6.2 | | 47.7 | | ns |
| SD4 | $t_{su}(CLKIH-CMDIV)$ | Hold time, mmc1_cmd valid after mmc1_clk rising clock edge | 19.4 | | 19.2 | | ns |
| SD7 | $t_{su}(DATxV-CLKIH)$ | Setup time, mmc1_datx valid before mmc1_clk rising clock edge | 6.2 | | 47.7 | | ns |
| SD8 | $t_{su}(CLKIH-DATxIV)$ | Hold time, mmc1_datx valid after mmc1_clk rising clock edge | 19.4 | | 19.2 | | ns |
| MMC/SD/SDIO Interface 1 (3.0 V IO) | | | | | | | |
| SD3 | $t_{su}(CMDV-CLKIH)$ | Setup time, mmc1_cmd valid before mmc1_clk rising clock edge | 6.2 | | 47.7 | | ns |
| SD4 | $t_{su}(CLKIH-CMDIV)$ | Hold time, mmc1_cmd valid after mmc1_clk rising clock edge | 19.4 | | 19.2 | | ns |
| SD7 | $t_{su}(DATxV-CLKIH)$ | Setup time, mmc1_datx valid before mmc1_clk rising clock edge | 6.2 | | 47.7 | | ns |
| SD8 | $t_{su}(CLKIH-DATxIV)$ | Hold time, mmc1_datx valid after mmc1_clk rising clock edge | 19.4 | | 19.2 | | ns |
| MMC/SD/SDIO Interface 2 | | | | | | | |
| SD3 | $t_{su}(CMDV-CLKIH)$ | Setup time, mmc2_cmd valid before mmc2_clk rising clock edge | 6.2 | | 47.7 | | ns |
| SD4 | $t_{su}(CLKIH-CMDIV)$ | Hold time, mmc2_cmd valid after mmc2_clk rising clock edge | 19.4 | | 19.2 | | ns |
| SD7 | $t_{su}(DATxV-CLKIH)$ | Setup time, mmc2_datx valid before mmc2_clk rising clock edge | 6.2 | | 47.7 | | ns |
| SD8 | $t_{su}(CLKIH-DATxIV)$ | Hold time, mmc2_datx valid after mmc2_clk rising clock edge | 19.4 | | 19.2 | | ns |
| MMC/SD/SDIO Interface 3 | | | | | | | |
| SD3 | $t_{su}(CMDV-CLKIH)$ | Setup time, mmc3_cmd valid before mmc3_clk rising clock edge | 6.2 | | 47.7 | | ns |
| SD4 | $t_{su}(CLKIH-CMDIV)$ | Hold time, mmc3_cmd valid after mmc3_clk rising clock edge | 19.4 | | 19.2 | | ns |
| SD7 | $t_{su}(DATxV-CLKIH)$ | Setup time, mmc3_datx valid before mmc3_clk rising clock edge | 6.2 | | 47.7 | | ns |
| SD8 | $t_{su}(CLKIH-DATxIV)$ | Hold time, mmc3_datx valid after mmc3_clk rising clock edge | 19.4 | | 19.2 | | ns |

- (1) Timing parameters are referred to output clock specified in [Table 6-139](#).
- (2) The timing requirements are assured for the cycle jitter and duty cycle error conditions specified in [Table 6-139](#).
- (3) In datx, x is equal to 1, 2, 3, 4, 5, 6, or 7.

Table 6-139. MMC/SD/SDIO Switching Characteristics – Standard SD Mode

| NO. | PARAMETER | | 1.15 V | | 1.0 V | | UNIT |
|-------------------------|----------------|---|--------------------------|-----|--------------------------|-----|------|
| | | | MIN | MAX | MIN | MAX | |
| Standard SD Mode | | | | | | | |
| 1/SD 1 | $1/t_{c}(clk)$ | Frequency ⁽¹⁾ , mmc _x _clk ⁽²⁾ | | 24 | | 12 | MHz |
| SD2 | $t_{W}(clkH)$ | Typical pulse duration, output clk high | $X^{(3)} \cdot PO^{(4)}$ | | $X^{(3)} \cdot PO^{(4)}$ | | ns |

- (1) Related with the output clk maximum and minimum frequencies programmable in I/F module.
- (2) In mmc_x_clk, 'x' is equal to 1, 2, or 3.
- (3) The X parameter is defined as shown in [Table 6-140](#).
- (4) PO = output clk period in ns.

Table 6-139. MMC/SD/SDIO Switching Characteristics – Standard SD Mode (continued)

| NO. | PARAMETER | | 1.15 V | | 1.0 V | | UNIT |
|---|----------------------------|--|--------------------------|--------|--------------------------|--------|------|
| | | | MIN | MAX | MIN | MAX | |
| SD2 | $t_{W(\text{clkL})}$ | Typical pulse duration, output clk low | $Y^{(5)} \cdot PO^{(4)}$ | | $Y^{(5)} \cdot PO^{(4)}$ | | ns |
| | $t_{dc(\text{clk})}$ | Duty cycle error, output clk | | 2083.3 | | 4166.7 | ps |
| | $t_{j(\text{clk})}$ | Jitter standard deviation ⁽⁶⁾ , output clk | | 200 | | 200 | ps |
| MMC/SD/SDIO Interface 1 (1.8 V IO) | | | | | | | |
| | $t_{c(\text{clk})}$ | Rise time, output clk | | 10 | | 10 | ns |
| | $t_{W(\text{clkH})}$ | Fall time, output clk | | 10 | | 10 | ns |
| | $t_{W(\text{clkL})}$ | Rise time, output data | | 10 | | 10 | ns |
| | $t_{dc(\text{clk})}$ | Fall time, output data | | 10 | | 10 | ns |
| SD5 | $t_{d(\text{CLKOH-CMD})}$ | Delay time, mmc1_clk rising clock edge to mmc1_cmd transition | 6.1 | 35.5 | 6.3 | 77 | ns |
| SD6 | $t_{d(\text{CLKOH-DATx})}$ | Delay time, mmc1_clk rising clock edge to mmc1_datx transition | 6.1 | 35.5 | 6.3 | 77 | ns |
| MMC/SD/SDIO Interface 1 (3.0 V IO) | | | | | | | |
| | $t_{c(\text{clk})}$ | Rise time, output clk | | 10 | | 10 | ns |
| | $t_{W(\text{clkH})}$ | Fall time, output clk | | 10 | | 10 | ns |
| | $t_{W(\text{clkL})}$ | Rise time, output data | | 10 | | 10 | ns |
| | $t_{dc(\text{clk})}$ | Fall time, output data | | 10 | | 10 | ns |
| SD5 | $t_{d(\text{CLKOH-CMD})}$ | Delay time, mmc1_clk rising clock edge to mmc1_cmd transition | 6.1 | 35.5 | 6.3 | 77 | ns |
| SD6 | $t_{d(\text{CLKOH-DATx})}$ | Delay time, mmc1_clk rising clock edge to mmc1_datx transition | 6.1 | 35.5 | 6.3 | 77 | ns |
| MMC/SD/SDIO Interface 2 | | | | | | | |
| | $t_{c(\text{clk})}$ | Rise time, output clk | | 10 | | 10 | ns |
| | $t_{W(\text{clkH})}$ | Fall time, output clk | | 10 | | 10 | ns |
| | $t_{W(\text{clkL})}$ | Rise time, output data | | 10 | | 10 | ns |
| | $t_{dc(\text{clk})}$ | Fall time, output data | | 10 | | 10 | ns |
| SD5 | $t_{d(\text{CLKOH-CMD})}$ | Delay time, mmc2_clk rising clock edge to mmc2_cmd transition | 6.1 | 35.5 | 6.3 | 77 | ns |
| SD6 | $t_{d(\text{CLKOH-DATx})}$ | Delay time, mmc2_clk rising clock edge to mmc2_datx transition | 6.1 | 35.5 | 6.3 | 77 | ns |
| MMC/SD/SDIO Interface 3 | | | | | | | |
| | $t_{c(\text{clk})}$ | Rise time, output clk | | 10 | | 10 | ns |
| | $t_{W(\text{clkH})}$ | Fall time, output clk | | 10 | | 10 | ns |
| | $t_{W(\text{clkL})}$ | Rise time, output data | | 10 | | 10 | ns |
| | $t_{dc(\text{clk})}$ | Fall time, output data | | 10 | | 10 | ns |
| SD5 | $t_{d(\text{CLKOH-CMD})}$ | Delay time, mmc3_clk rising clock edge to mmc3_cmd transition | 6.1 | 35.5 | 6.3 | 77 | ns |
| SD6 | $t_{d(\text{CLKOH-DATx})}$ | Delay time, mmc3_clk rising clock edge to mmc3_datx transition | 6.1 | 35.5 | 6.3 | 77 | ns |

(5) The Y parameter is defined as shown in [Table 6-141](#).

(6) The jitter probability density can be approximated by a Gaussian function.

Table 6-140. X Parameter

| CLKD | X |
|-----------|---|
| 1 or Even | 0.5 |
| Odd | $(\text{trunk}[\text{CLKD}/2]+1)/\text{CLKD}$ |

Table 6-141. Y Parameter

| CLKD | Y |
|-----------|----------------------|
| 1 or Even | 0.5 |
| Odd | (trunk[CLKD/2])/CLKD |

For details about clock division factor CLKD, see the *OMAP35x Technical Reference Manual (TRM)* [literature number [SPRUF98](#)].

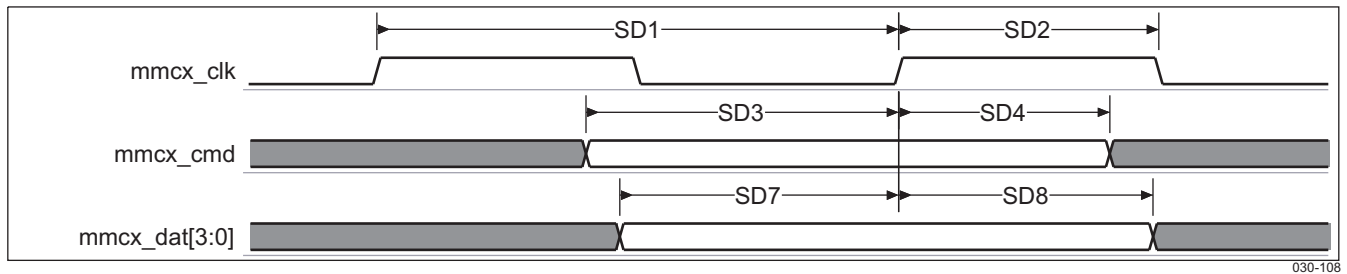

In mmc_x, x is equal to 1, 2, or 3.

Figure 6-67. MMC/SD/SDIO – Standard SD Mode – Data/Command Receive

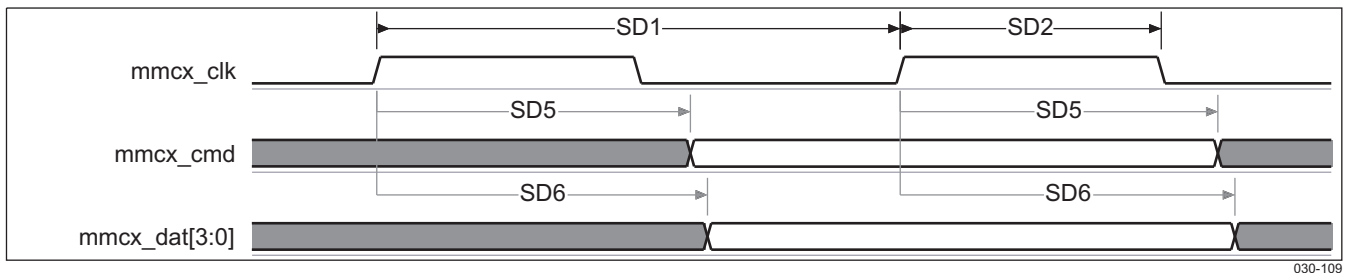

In mmc_x, x is equal to 1, 2, or 3.

Figure 6-68. MMC/SD/SDIO – Standard SD Mode – Data/Command Transmit

6.8 Test Interfaces

The emulation and trace interfaces allow tracing activities of the following CPUs:

- ARM1136JF-STM through an Embedded Trace Macro-cell (ETM11) dedicated to enable real-time trace of the ARM subsystem operations and a Serial Debug Trace Interface (SDTI)
- IVA2 DSP through a high-speed real-time data exchange (HS-RTDX) controller

All processors can be emulated via JTAG ports.

6.8.1 Embedded Trace Macro Interface (ETM)

Table 6-142 assumes testing over the recommended operating conditions (see Figure 6-69).

Table 6-142. Embedded Trace Macro Interface Switching Characteristics⁽¹⁾

| NO. | PARAMETER | | 1.15 V | | UNIT |
|------|-------------------------|--|--------|-----|------|
| | | | MIN | MAX | |
| f | $1/t_{c(\text{CLK})}$ | Frequency, etk_clk | | 166 | MHz |
| ETM0 | $t_{c(\text{CLK})}$ | Cycle time ⁽²⁾ , etk_clk | 6 | | ns |
| ETM1 | $t_{W(\text{CLK})}$ | Clock pulse width, etk_clk | 2.7 | | ns |
| ETM2 | $t_{d(\text{CLK-CTL})}$ | Delay time, etk_clk clock edge to etk_ctl transition | -0.5 | 0.5 | ns |
| ETM3 | $t_{d(\text{CLK-D})}$ | Delay time, etk_clk clock high to etk_d[15:0] transition | -0.5 | 0.5 | ns |

(1) The capacitive load is equivalent to 25 pF.

(2) Cycle time is given by considering a jitter of 5%.

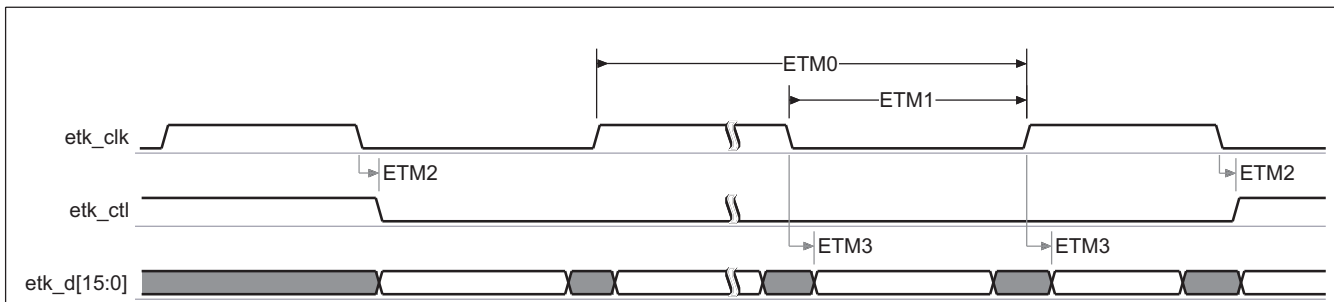

030-110

Figure 6-69. Embedded Trace Macro Interface

6.8.2 System Debug Trace Interface (SDTI)

The system debug trace interface (SDTI) module provides real-time software tracing functionality to the OMAP3530/25 device.

The trace interface has four trace data pins and a trace clock pin.

This interface is a dual-edge interface: the data are available on rising and falling edges of sdti_clk but can be also configured in single edge mode where data are available on falling edge of sdti_clk.

Serial interface operates in clock stop regime: serial clock is not free running, when there is no trace data there is no trace clock.

6.8.2.1 System Debug Trace Interface in Dual-Edge Mode

Table 6-144 assumes testing over the recommended operating conditions and electrical characteristic conditions (see Figure 6-70).

Table 6-143. System Debug Trace Interface Timing Conditions – Dual-Edge Mode

| TIMING CONDITION PARAMETER | | VALUE | UNIT |
|----------------------------|-------------------------|-------|------|
| Output Conditions | | | |
| C _{LOAD} | Output load capacitance | 25 | pF |

Table 6-144. System Debug Trace Interface Switching Characteristics – Dual-Edge Mode

| NO. | PARAMETER | | 1.15 V | | 1.0 V | | UNIT |
|-----|--------------------------|--|----------------------|------|----------------------|------|------|
| | | | MIN | MAX | MIN | MAX | |
| SD1 | t _c (CLK) | Cycle time, sdti_clk period | 29 | | 29 | | ns |
| SD2 | t _w (CLK) | Typical pulse duration, sdti_clk high or low | 0.5*P ⁽¹⁾ | | 0.5*P ⁽¹⁾ | | ns |
| | t _{dc} (CLK) | Duty cycle error, sdti_clk | -1.2 | 1.2 | -1.2 | 1.2 | ns |
| | t _R (CLK) | Rise time, sdti_clk | | 5 | | 5 | ns |
| | t _F (CLK) | Fall time, sdti_clk | | 5 | | 5 | ns |
| SD3 | t _d (CLK-TxD) | Multiplexing mode on etk pins | 2.3 | 10.9 | 2.3 | 10.9 | ns |
| | | Multiplexing mode on jtag_emu pins | 2.3 | 13.9 | 2.3 | 13.9 | |
| | t _R (CLK) | Rise time, sdti_txd[3:0] | | 5 | | 5 | ns |
| | t _F (CLK) | Fall time, sdti_txd[3:0] | | 5 | | 5 | ns |

(1) P = sdti_clk clock period

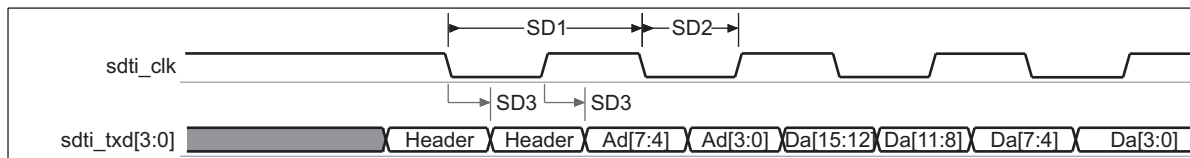

030-111

Figure 6-70. System Debug Trace Interface – Dual-Edge Mode

6.8.2.2 System Debug Trace Interface in Single-Edge Mode

Table 6-146 assumes testing over the recommended operating conditions and electrical characteristic conditions (see Figure 6-71).

Table 6-145. System Debug Trace Interface Timing Conditions – Single-Edge Mode

| TIMING CONDITION PARAMETER | | VALUE | UNIT |
|----------------------------|-------------------------|-------|------|
| Output Conditions | | | |
| C _{LOAD} | Output load capacitance | 25 | pF |

Table 6-146. System Debug Trace Interface Switching Characteristics – Single-Edge Mode

| NO. | PARAMETER | | 1.15 V | | 1.0 V | | UNIT |
|-----|--------------------------|--|----------------------|------|----------------------|------|------|
| | | | MIN | MAX | MIN | MAX | |
| SD1 | t _c (CLK) | Cycle time, sdti_clk period | 29 | | 29 | | ns |
| SD2 | t _w (CLK) | Typical pulse duration, sdti_clk high or low | 0.5*P ⁽¹⁾ | | 0.5*P ⁽¹⁾ | | ns |
| | t _{dc} (CLK) | Duty cycle error, sdti_clk | -1.2 | 1.2 | -1.2 | 1.2 | ns |
| | t _R (CLK) | Rise time, sdti_clk | | 5 | | 5 | ns |
| | t _F (CLK) | Fall time, sdti_clk | | 5 | | 5 | ns |
| SD3 | t _d (CLK-TxD) | Multiplexing mode on etk pins | 2.3 | 26.5 | 2.3 | 26.5 | ns |
| | | Multiplexing mode on jtag_emu pins | 2.3 | 33.2 | 2.3 | 33.2 | |
| | t _R (CLK) | Rise time, sdti_txd[3:0] | | 5 | | 5 | ns |

(1) P = sdti_clk clock period.

Table 6-146. System Debug Trace Interface Switching Characteristics – Single-Edge Mode (continued)

| NO. | PARAMETER | | 1.15 V | | 1.0 V | | UNIT |
|-----|--------------|---------------------------------------|--------|-----|-------|-----|------|
| | | | MIN | MAX | MIN | MAX | |
| | $t_{F(CLK)}$ | Fall time, <code>sdti_txd[3:0]</code> | | 5 | | 5 | ns |

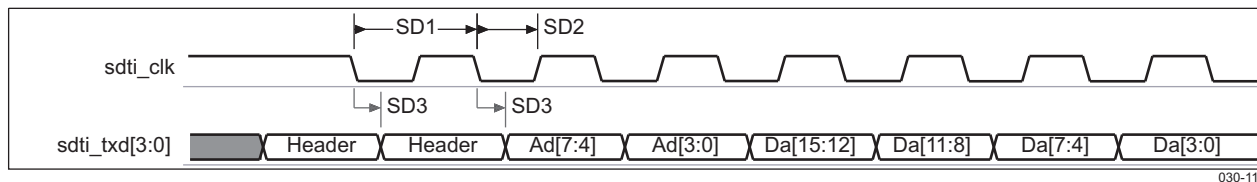

030-112

Figure 6-71. System Debug Trace Interface – Single-Edge Mode

6.8.3 JTAG Interfaces

OMAP3530/25 JTAG TAP controller handles standard IEEE JTAG interfaces. The following sections define the timing requirements for several tools used to test the OMAP3530/25 processors as:

- Free running clock tool, like XDS560 and XDS510 tools
- Adaptive clock tool, like RealView® ICE tool and Lauterbach™ tool

6.8.3.1 JTAG – Free Running Clock Mode

Table 6-148 and Table 6-149 assume testing over the recommended operating conditions and electrical characteristic conditions (see Figure 6-72).

Table 6-147. JTAG Timing Conditions – Free Running Clock Mode

| TIMING CONDITION PARAMETER | | VALUE | UNIT |
|----------------------------|-------------------------|-------|------|
| Input Conditions | | | |
| t_R | Input signal rise time | 5 | ns |
| t_F | Input signal fall time | 5 | ns |
| Output Conditions | | | |
| C_{LOAD} | Output load capacitance | 30 | pF |

Table 6-148. JTAG Timing Requirements – Free Running Clock Mode⁽¹⁾

| NO. | PARAMETER | | 1.15 V | | 1.0 V | | UNIT |
|------|----------------------|--|----------------------|------|----------------------|------|------|
| | | | MIN | MAX | MIN | MAX | |
| JT4 | $t_{c(tck)}$ | Cycle time ⁽²⁾ , <code>jtag_tck</code> period | 25 | | 33 | | ns |
| JT5 | $t_{w(tckL)}$ | Typical pulse duration, <code>jtag_tck</code> low | 0.5*P ⁽³⁾ | | 0.5*P ⁽³⁾ | | ns |
| JT6 | $t_{w(tckH)}$ | Typical pulse duration, <code>jtag_tck</code> high | 0.5*P ⁽³⁾ | | 0.5*P ⁽³⁾ | | ns |
| | $t_{dc(tck)}$ | Duty cycle error, <code>jtag_tck</code> | -1250 | 1250 | -1667 | 1667 | ps |
| | $t_{j(tck)}$ | Cycle jitter ⁽⁴⁾ , <code>jtag_tck</code> | -1250 | 1250 | -1667 | 1667 | ps |
| JT7 | $t_{su(tdiV-rtckH)}$ | Setup time, <code>jtag_tdi</code> valid before <code>jtag_rtck</code> high | 1.8 | | 1.8 | | ns |
| JT8 | $t_{h(tdiV-rtckH)}$ | Hold time, <code>jtag_tdi</code> valid after <code>jtag_rtck</code> high | 0.7 | | 1 | | ns |
| JT9 | $t_{su(tmsV-rtckH)}$ | Setup time, <code>jtag_tms</code> valid before <code>jtag_rtck</code> high | 1.8 | | 1.8 | | ns |
| JT10 | $t_{h(tmsV-rtckH)}$ | Hold time, <code>jtag_tms</code> valid after <code>jtag_rtck</code> high | 0.7 | | 1 | | ns |
| JT12 | $t_{su(emuV-rtckH)}$ | Setup time, <code>jtag_emux</code> ⁽⁵⁾ valid before <code>jtag_rtck</code> high | 14.6 | | 19.8 | | ns |
| JT13 | $t_{h(emuV-rtckH)}$ | Hold time, <code>jtag_emux</code> ⁽⁵⁾ valid after <code>jtag_rtck</code> high | 2 | | 2.7 | | ns |

(1) The timing requirements are assured for the cycle jitter and duty cycle error conditions specified.

(2) Related with the input maximum frequency supported by the JTAG module.

(3) P = `jtag_tck` period in ns.

(4) Maximum cycle jitter supported by `jtag_tck` input clock.

(5) x = 0 to 1

Table 6-149. JTAG Switching Characteristics – Free Running Clock Mode

| NO. | PARAMETER | | 1.15 V | | 1.0 V | | UNIT |
|------|---------------------------|---|-----------------------|------|-----------------------|------|------|
| | | | MIN | MAX | MIN | MAX | |
| JT1 | $t_{c(rtck)}$ | Cycle time ⁽¹⁾ , jtag_rtck period | 25 | | 33 | | ns |
| JT2 | $t_w(rtckL)$ | Typical pulse duration, jtag_rtck low | 0.5*PO ⁽²⁾ | | 0.5*PO ⁽²⁾ | | ns |
| JT3 | $t_w(rtckH)$ | Typical pulse duration, jtag_rtck high | 0.5*PO ⁽²⁾ | | 0.5*PO ⁽²⁾ | | ns |
| | $t_{dc(rtck)}$ | Duty cycle error, jtag_rtck | -1250 | 1250 | -1667 | 1667 | ps |
| | $t_j(rtck)$ | Jitter standard deviation ⁽³⁾ , jtag_rtck | | 33.3 | | 33.3 | ps |
| | $t_R(rtck)$ | Rise time, jtag_rtck | | 4 | | 4 | ns |
| | $t_F(rtck)$ | Fall time, jtag_rtck | | 4 | | 4 | ns |
| JT11 | $t_d(rtckL\text{-}tdoV)$ | Delay time, jtag_rtck low to jtag_tdo valid | -5.8 | 5.8 | -7.9 | 7.9 | ns |
| | $t_R(tdo)$ | Rise time, jtag_tdo | | 4 | | 4 | ns |
| | $t_F(tdo)$ | Fall time, jtag_tdo | | 4 | | 4 | ns |
| JT14 | $t_d(rtckH\text{-}emuxV)$ | Delay time, jtag_rtck high to ,jtag_emux ⁽⁴⁾ valid | 2.7 | 15.1 | 2.7 | 20.4 | ns |
| | $t_R(emux)$ | Rise time, jtag_emux ⁽⁴⁾ | | 6 | | 6 | ns |
| | $t_F(emux)$ | Fall time, jtag_emux ⁽⁴⁾ | | 6 | | 6 | ns |

- (1) Related with the jtag_rtck maximum frequency.
- (2) PO = jtag_rtck period in ns.
- (3) The jitter probability density can be approximated by a Gaussian function.
- (4) x = 0 to 1

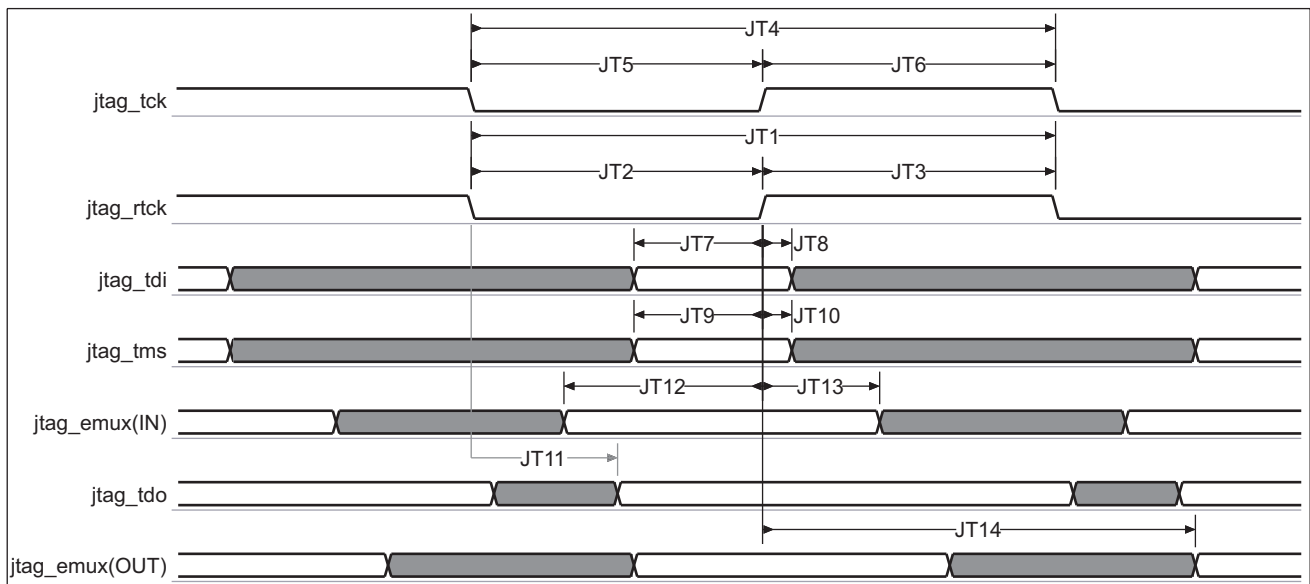

030-113

In jtag_emux, x is equal to 0 to 1.

Figure 6-72. JTAG Interface Timing – Free Running Clock Mode

6.8.3.2 JTAG – Adaptive Clock Mode

Table 6-151 and Table 6-152 assume testing over the recommended operating conditions and electrical characteristic conditions (see Figure 6-73):

Table 6-150. JTAG Timing Conditions – Adaptive Clock Mode

| TIMING CONDITION PARAMETER | | VALUE | UNIT |
|----------------------------|-------------------------|-------|------|
| Input Conditions | | | |
| t_R | Input signal rise time | 5 | ns |
| t_F | Input signal fall time | 5 | ns |
| Output Conditions | | | |
| C_{LOAD} | Output load capacitance | 30 | pF |

Table 6-151. JTAG Timing Requirements – Adaptive Clock Mode⁽¹⁾

| NO. | PARAMETER | | 1.15 V | | 1.0 V | | UNIT |
|------|---------------------|---|----------------------|------|----------------------|------|------|
| | | | MIN | MAX | MIN | MAX | |
| JA4 | $t_{c(tck)}$ | Cycle time ⁽²⁾ , jtag_tck period | 50 | | 50 | | ns |
| JA5 | $t_{w(tckL)}$ | Typical pulse duration, jtag_tck low | 0.5*P ⁽³⁾ | | 0.5*P ⁽³⁾ | | ns |
| JA6 | $t_{w(tckH)}$ | Typical pulse duration, jtag_tck high | 0.5*P ⁽³⁾ | | 0.5*P ⁽³⁾ | | ns |
| | $t_{dc(lclk)}$ | Duty cycle error, jtag_tck | -2500 | 2500 | -2500 | 2500 | ps |
| | $t_{j(lclk)}$ | Cycle jitter ⁽⁴⁾ , jtag_tck | -1500 | 1500 | -1500 | 1500 | ps |
| JA7 | $t_{su(tdiV-tckH)}$ | Setup time, jtag_tdi valid before jtag_tck high | 13.8 | | 13.8 | | ns |
| JA8 | $t_{h(tdiV-tckH)}$ | Hold time, jtag_tdi valid after jtag_tck high | 13.8 | | 13.8 | | ns |
| JA9 | $t_{su(tmsV-tckH)}$ | Setup time, jtag_tms valid before jtag_tck high | 13.8 | | 13.8 | | ns |
| JA10 | $t_{h(tmsV-tckH)}$ | Hold time, jtag_tms valid after jtag_tck high | 13.8 | | 13.8 | | ns |

(1) The timing requirements are assured for the cycle jitter and duty cycle error conditions specified.

(2) Related with the input maximum frequency supported by the JTAG module.

(3) P = jtag_tck period in ns.

(4) Maximum cycle jitter supported by jtag_tck input clock.

Table 6-152. JTAG Switching Characteristics – Adaptive Clock Mode

| NO. | PARAMETER | | 1.15 V | | 1.0 V | | UNIT |
|------|---------------------|--|-----------------------|------|-----------------------|------|------|
| | | | MIN | MAX | MIN | MAX | |
| JA1 | $t_{c(rtck)}$ | Cycle time ⁽¹⁾ , jtag_rtck period | 50 | | 50 | | ns |
| JA2 | $t_{w(rtckL)}$ | Typical pulse duration, jtag_rtck low | 0.5*PO ⁽²⁾ | | 0.5*PO ⁽²⁾ | | ns |
| JA3 | $t_{w(rtckH)}$ | Typical pulse duration, jtag_rtck high | 0.5*PO ⁽²⁾ | | 0.5*PO ⁽²⁾ | | ns |
| | $t_{dc(rtck)}$ | Duty cycle error, jtag_rtck | -2500 | 2500 | -2500 | 2500 | ps |
| | $t_{j(rtck)}$ | Jitter standard deviation ⁽³⁾ , jtag_rtck | | 33.3 | | 33.3 | ps |
| | $t_{R(rtck)}$ | Rise time, jtag_rtck | | 4 | | 4 | ns |
| | $t_{F(rtck)}$ | Fall time, jtag_rtck | | 4 | | 4 | ns |
| JA11 | $t_{d(rtckL-tdoV)}$ | Delay time, jtag_rtck low to jtag_tdo valid | -14.6 | 14.6 | -14.6 | 14.6 | ns |
| | $t_{R(tdo)}$ | Rise time, jtag_tdo, | | 4 | | 4 | ns |
| | $t_{F(tdo)}$ | Fall time, jtag_tdo | | 4 | | 4 | ns |

(1) Related with the jtag_rtck maximum frequency programmable.

(2) PO = jtag_rtck period in ns.

(3) The jitter probability density can be approximated by a Gaussian function.



Figure 6-73. JTAG Interface Timing – Adaptive Clock Mode

7 PACKAGE CHARACTERISTICS

7.1 Package Thermal Resistance

Table 7-1 provides the thermal resistance characteristics for the recommended package types used on the OMAP3530/25 Applications Processor.

Table 7-1. OMAP3530/25 Thermal Resistance Characteristics^{(1) (2)}

| Package | Power (W) ⁽³⁾ | R _{θJA} (°C/W) | R _{θJB} (°C/W) | R _{θJC} (°C/W) ⁽⁴⁾ | Board Type |
|----------------------------|--------------------------|-------------------------|-------------------------|--|------------------------------------|
| OMAP3530/25 (CBB Pkg.) | 0.92871 | 24.46 | 10.94 | | ⁽⁵⁾ 2S2P ⁽⁶⁾ |
| OMAP35 30/25 (CBC Pkg.) | 0.92871 | 21.89 | 6.23 | ⁽⁵⁾ | 2S2P ⁽⁶⁾ |
| OMAP35 30/25 (CUS Pkg.) | 0.92871 | 23.69 | 8.1 | 2.31 | 2S2P ⁽⁶⁾ |

(1) R_{θJA} (Theta-JA) = Thermal Resistance Junction-to-Ambient, °C/W

(2) This table provides simulation data and may not represent actual use-case values.

R_{θJB} (Theta-JB) = Thermal Resistance Junction-to-Board, °C/W

R_{θJC} (Theta-JC) = Thermal Resistance Junction-to-Case, °C/W

(3) These numbers are based on simulation results and don't necessarily represent the wattage that the part will take in actual use.

(4) It is recommended to dissipate the heat to the board instead of attempting to remove it from the top of the chip; therefore, top-side heat sinks should not be used for package.

(5) Not applicable if the POP package has a memory package on top; no heat sink can be used.

(6) The board types are defined by JEDEC (reference JEDEC standard JESD51-9, Test Board for Area Array Surface Mount Package Thermal Measurements).

7.2 Device Support

7.2.1 Device and Development-Support Tool Nomenclature

To designate the stages in the product development cycle, TI assigns prefixes to the part numbers of all OMAP processors and support tools. Each OMAP device has one of three prefixes: X, P, or null (no prefix). Texas Instruments recommends two of three possible prefix designators for its support tools: TMDX and TMDS. These prefixes represent evolutionary stages of product development from engineering prototypes (TMDX) through fully qualified production devices/tools (TMDS).

Device development evolutionary flow:

X Experimental device that is not necessarily representative of the final device's electrical specifications and may not use production assembly flow. (TMX definition)

P Prototype device that is not necessarily the final silicon die and may not necessarily meet final electrical specifications. (TMP definition)

null Production version of the silicon die that is fully qualified. (TMS definition)

Support tool development evolutionary flow:

TMDX Development support product that has not yet completed Texas Instruments internal qualification testing.

TMDS Fully qualified development support product.

TMX and TMP devices and TMDX development-support tools are shipped against the following disclaimer:

"Developmental product is intended for internal evaluation purposes."

Production devices and TMDS development-support tools have been characterized fully, and the quality and reliability of the device have been demonstrated fully. TI's standard warranty applies.

Predictions show that prototype devices (X or P), have a greater failure rate than the standard production devices. Texas Instruments recommends that these devices not be used in any production system because their expected end-use failure rate still is undefined. Only qualified production devices are to be used.

For additional description of the device nomenclature markings, see the *OMAP35x Applications Processor Silicon Errata* (literature number [SPRZ278](#)).

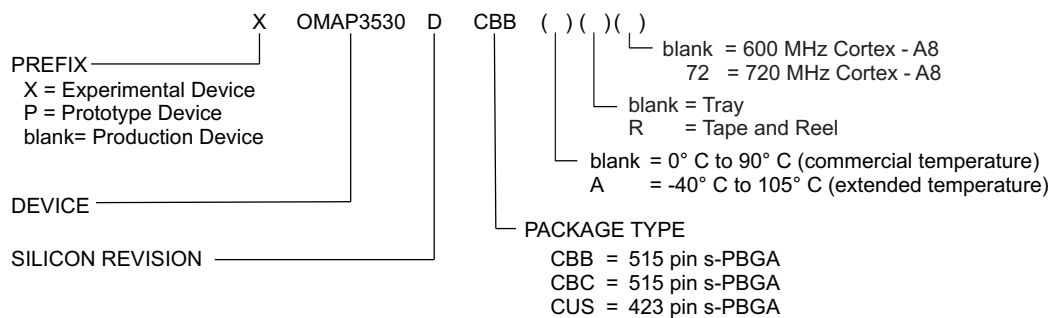

- A. For more information on the silicon revision, please see the *OMAP3530/25/15/03 Applications Processor Silicon Errata* (literature number [SPRZ278](#)).

Figure 7-1. Device Nomenclature^(A)

7.2.2 Documentation Support

7.2.2.1 Related Documentation from Texas Instruments

The following documents describe the OMAP3530/25 Applications Processor. Copies of these documents are available on the Internet at www.ti.com. Tip: Enter the literature number in the search box provided at www.ti.com.

The current documentation that describes the OMAP3530/25 Applications Processor, related peripherals, and other technical collateral, is available in the product folder at: www.ti.com.

[SPRUF98](#) *OMAP35x Technical Reference Manual.* Collection of documents providing detailed information on the OMAP3 architecture including power, reset, and clock control, interrupts, memory map, and switch fabric interconnect. Detailed information on the microprocessor unit (MPU) subsystem, the image, video, and audio (IVA2.2) subsystem, as well a functional description of the peripherals supported on OMAP35x devices is also included.

[SPRU732](#) *TMS320C64x/C64x+ DSP CPU and Instruction Set Reference Guide.* Describes the CPU architecture, pipeline, instruction set, and interrupts for the TMS320C64x and TMS320C64x+ digital signal processors (DSPs) of the TMS320C6000 DSP family. The C64x/C64x+ DSP generation comprises fixed-point devices in the C6000 DSP platform. The C64x+ DSP is an enhancement of the C64x DSP with added functionality and an expanded instruction set.

[SPRU871](#) *TMS320C64x+ DSP Megamodule Reference Guide.* Describes the TMS320C64x+ digital signal processor (DSP) megamodule. Included is a discussion on the internal direct memory access (IDMA) controller, the interrupt controller, the power-down controller, memory protection, bandwidth management, and the memory and cache.

[SPRU889](#) *High-Speed DSP Systems Design Reference Guide.* Provides recommendations for meeting the many challenges of high-speed DSP system design. These recommendations include information about DSP audio, video, and communications systems for the C5000 and C6000 DSP platforms.

7.2.2.2 Related Documentation from Other Sources

The following documents are related to the OMAP3530/25 Applications Processor. Copies of these documents can be obtained directly from the internet or from your Texas Instruments representative.

CortexTM-A8 Technical Reference Manual. This is the technical reference manual for the Cortex-A8 processor. A copy of this document can be obtained via the internet at <http://infocenter.arm.com>. Please see the *OMAP35x Applications Processor Silicon Errata* (literature number [SPRZ278](#)) to determine the revision of the Cortex-A8 core used on your device.

ARM Core CortexTM-A8 (AT400/AT401) Errata Notice. Provides a list of advisories for the different revisions of the Cortex-A8 processor. Contact your TI representative for a copy of this document. Please see the *OMAP35x Applications Processor Silicon Errata* (literature number [SPRZ278](#)) to determine the revision of the Cortex-A8 core used on your device.

PACKAGING INFORMATION

| Orderable Device | Status ⁽¹⁾ | Package Type | Package Drawing | Pins | Package Qty | Eco Plan ⁽²⁾ | Lead/ Ball Finish | MSL Peak Temp ⁽³⁾ | Samples (Requires Login) |
|------------------|-----------------------|--------------|-----------------|------|-------------|----------------------------|----------------------|------------------------------|-----------------------------|
| OMAP3525DCBB | ACTIVE | POP-FCBGA | CBB | 515 | 168 | Green (RoHS & no Sb/Br) | Call TI | Level-3-260C-168 HR | |
| OMAP3525DCBBA | ACTIVE | POP-FCBGA | CBB | 515 | 168 | Green (RoHS & no Sb/Br) | Call TI | Level-3-260C-168 HR | |
| OMAP3525DCBC | ACTIVE | POP-FCBGA | CBC | 515 | 119 | Green (RoHS & no Sb/Br) | Call TI | Level-3-260C-168 HR | |
| OMAP3525DCBCA | ACTIVE | POP-FCBGA | CBC | 515 | 119 | Green (RoHS & no Sb/Br) | Call TI | Level-3-260C-168 HR | |
| OMAP3525DCUS | ACTIVE | FCBGA | CUS | 423 | 90 | Green (RoHS & no Sb/Br) | Call TI | Level-4-260C-72 HR | |
| OMAP3525DCUSA | ACTIVE | FCBGA | CUS | 423 | 90 | Green (RoHS & no Sb/Br) | Call TI | Level-4-260C-72 HR | |
| OMAP3530DCBB | ACTIVE | POP-FCBGA | CBB | 515 | 1 | Green (RoHS & no Sb/Br) | Call TI | Level-3-260C-168 HR | |
| OMAP3530DCBB72 | ACTIVE | POP-FCBGA | CBB | 515 | 168 | Green (RoHS & no Sb/Br) | Call TI | Level-3-260C-168 HR | |
| OMAP3530DCBBA | ACTIVE | POP-FCBGA | CBB | 515 | 168 | Green (RoHS & no Sb/Br) | Call TI | Level-3-260C-168 HR | |
| OMAP3530DCBBD | OBSOLETE | POP-FCBGA | CBB | 515 | | TBD | Call TI | Call TI | |
| OMAP3530DCBBE | OBSOLETE | POP-FCBGA | CBB | 515 | | TBD | Call TI | Call TI | |
| OMAP3530DCBC | ACTIVE | POP-FCBGA | CBC | 515 | 119 | Green (RoHS & no Sb/Br) | Call TI | Level-3-260C-168 HR | |
| OMAP3530DCBC72 | ACTIVE | POP-FCBGA | CBC | 515 | 119 | Green (RoHS & no Sb/Br) | Call TI | Level-3-260C-168 HR | |
| OMAP3530DCBCA | ACTIVE | POP-FCBGA | CBC | 515 | 119 | Green (RoHS & no Sb/Br) | Call TI | Level-3-260C-168 HR | |
| OMAP3530DCUS | ACTIVE | FCBGA | CUS | 423 | 90 | Green (RoHS & no Sb/Br) | Call TI | Level-4-260C-72 HR | |
| OMAP3530DCUS72 | ACTIVE | FCBGA | CUS | 423 | 90 | Green (RoHS & no Sb/Br) | Call TI | Level-4-260C-72 HR | |
| OMAP3530DCUSA | ACTIVE | FCBGA | CUS | 423 | 90 | Green (RoHS & no Sb/Br) | Call TI | Level-4-260C-72 HR | |
| XOMAP3525CCBB | OBSOLETE | POP-FCBGA | CBB | 515 | | TBD | Call TI | Call TI | |

| Orderable Device | Status ⁽¹⁾ | Package Type | Package Drawing | Pins | Package Qty | Eco Plan ⁽²⁾ | Lead/Ball Finish | MSL Peak Temp ⁽³⁾ | Samples (Requires Login) |
|------------------|-----------------------|--------------|-----------------|------|-------------|-------------------------|------------------|------------------------------|--------------------------|
| XOMAP3525CCBC | OBSOLETE | POP-FCBGA | CBC | 515 | | TBD | Call TI | Call TI | |
| XOMAP3525CCUS | OBSOLETE | FCBGA | CUS | 423 | | TBD | Call TI | Call TI | |
| XOMAP3530BCBBE | OBSOLETE | POP-FCBGA | CBB | 515 | | TBD | Call TI | Call TI | |
| XOMAP3530CCBC | OBSOLETE | POP-FCBGA | CBC | 515 | | TBD | Call TI | Call TI | |
| XOMAP3530DCUSD | OBSOLETE | FCBGA | CUS | 423 | | TBD | Call TI | Call TI | |
| XOMAP3530DCUSE | OBSOLETE | FCBGA | CUS | 423 | | TBD | Call TI | Call TI | |
| XOMAP3530ECBB | OBSOLETE | POP-FCBGA | CBB | 515 | | TBD | Call TI | Call TI | |
| XOMAP3530FCBC | OBSOLETE | POP-FCBGA | CBC | 515 | | TBD | Call TI | Call TI | |
| XOMAP3530FCBCD | OBSOLETE | POP-FCBGA | CBC | 515 | | TBD | Call TI | Call TI | |
| XOMAP3530FCBCE | OBSOLETE | POP-FCBGA | CBC | 515 | | TBD | Call TI | Call TI | |
| XOMAP3530FCUS | OBSOLETE | FCBGA | CUS | 423 | | TBD | Call TI | Call TI | |
| XOMAP3530FCUSD | OBSOLETE | FCBGA | CUS | 423 | | TBD | Call TI | Call TI | |
| XOMAP3530FCUSE | OBSOLETE | FCBGA | CUS | 423 | | TBD | Call TI | Call TI | |

⁽¹⁾ The marketing status values are defined as follows:

ACTIVE: Product device recommended for new designs.

LIFEBUY: TI has announced that the device will be discontinued, and a lifetime-buy period is in effect.

NRND: Not recommended for new designs. Device is in production to support existing customers, but TI does not recommend using this part in a new design.

PREVIEW: Device has been announced but is not in production. Samples may or may not be available.

OBSOLETE: TI has discontinued the production of the device.

⁽²⁾ Eco Plan - The planned eco-friendly classification: Pb-Free (RoHS), Pb-Free (RoHS Exempt), or Green (RoHS & no Sb/Br) - please check <http://www.ti.com/productcontent> for the latest availability information and additional product content details.

TBD: The Pb-Free/Green conversion plan has not been defined.

Pb-Free (RoHS): TI's terms "Lead-Free" or "Pb-Free" mean semiconductor products that are compatible with the current RoHS requirements for all 6 substances, including the requirement that lead not exceed 0.1% by weight in homogeneous materials. Where designed to be soldered at high temperatures, TI Pb-Free products are suitable for use in specified lead-free processes.

Pb-Free (RoHS Exempt): This component has a RoHS exemption for either 1) lead-based flip-chip solder bumps used between the die and package, or 2) lead-based die adhesive used between the die and leadframe. The component is otherwise considered Pb-Free (RoHS compatible) as defined above.

Green (RoHS & no Sb/Br): TI defines "Green" to mean Pb-Free (RoHS compatible), and free of Bromine (Br) and Antimony (Sb) based flame retardants (Br or Sb do not exceed 0.1% by weight in homogeneous material)

⁽³⁾ MSL, Peak Temp. -- The Moisture Sensitivity Level rating according to the JEDEC industry standard classifications, and peak solder temperature.

Important Information and Disclaimer: The information provided on this page represents TI's knowledge and belief as of the date that it is provided. TI bases its knowledge and belief on information provided by third parties, and makes no representation or warranty as to the accuracy of such information. Efforts are underway to better integrate information from third parties. TI has taken and

continues to take reasonable steps to provide representative and accurate information but may not have conducted destructive testing or chemical analysis on incoming materials and chemicals. TI and TI suppliers consider certain information to be proprietary, and thus CAS numbers and other limited information may not be available for release.

In no event shall TI's liability arising out of such information exceed the total purchase price of the TI part(s) at issue in this document sold by TI to Customer on an annual basis.

CBB (S-PBGA-N515)

PLASTIC BALL GRID ARRAY

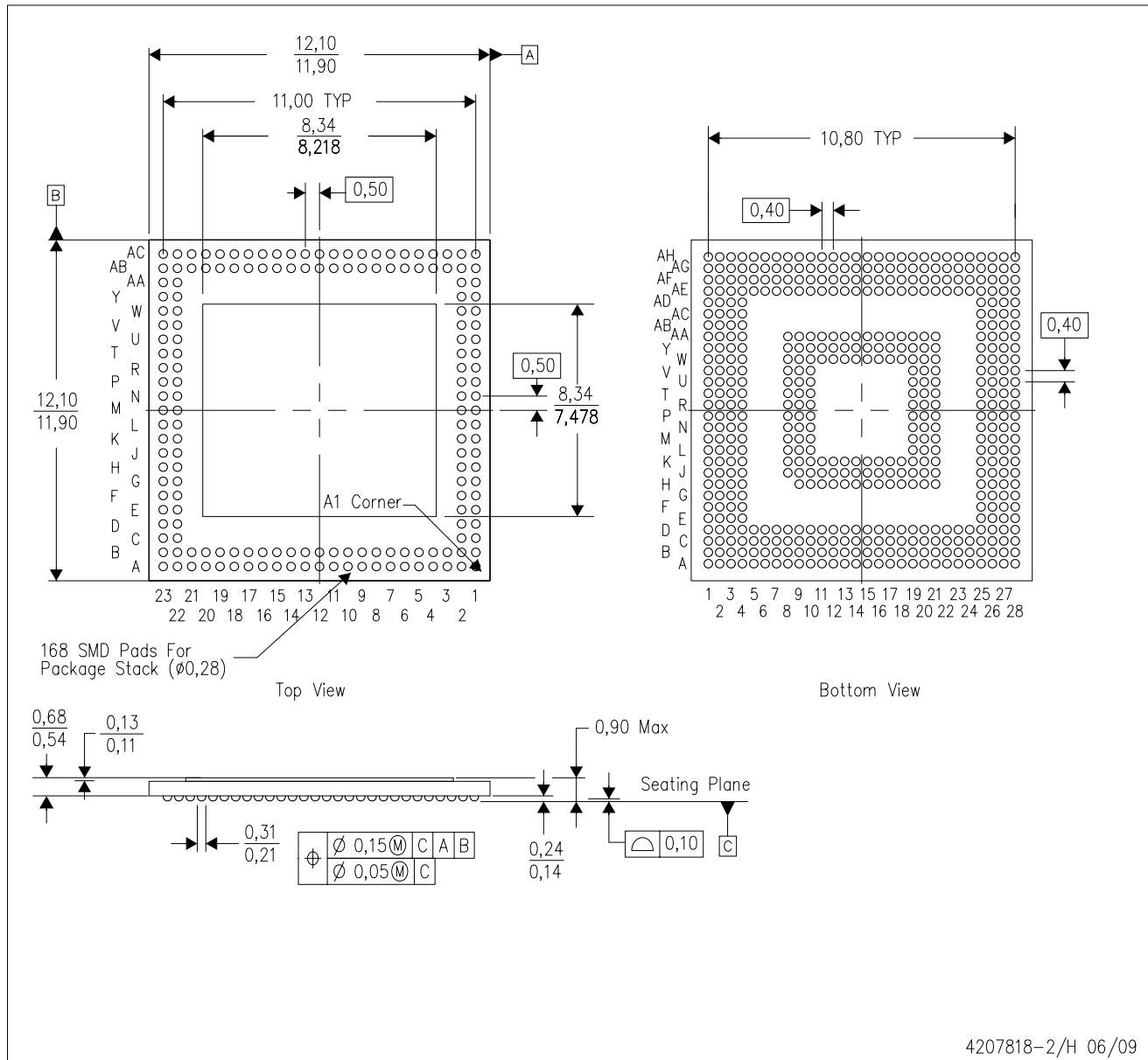

- NOTES:
- A. All linear dimensions are in millimeters.
 - B. This drawing is subject to change without notice.
 - C. Flip chip application only.
 - D. Pb-free die bump and solder ball.

CUS (S-PBGA-N423)

PLASTIC BALL GRID ARRAY

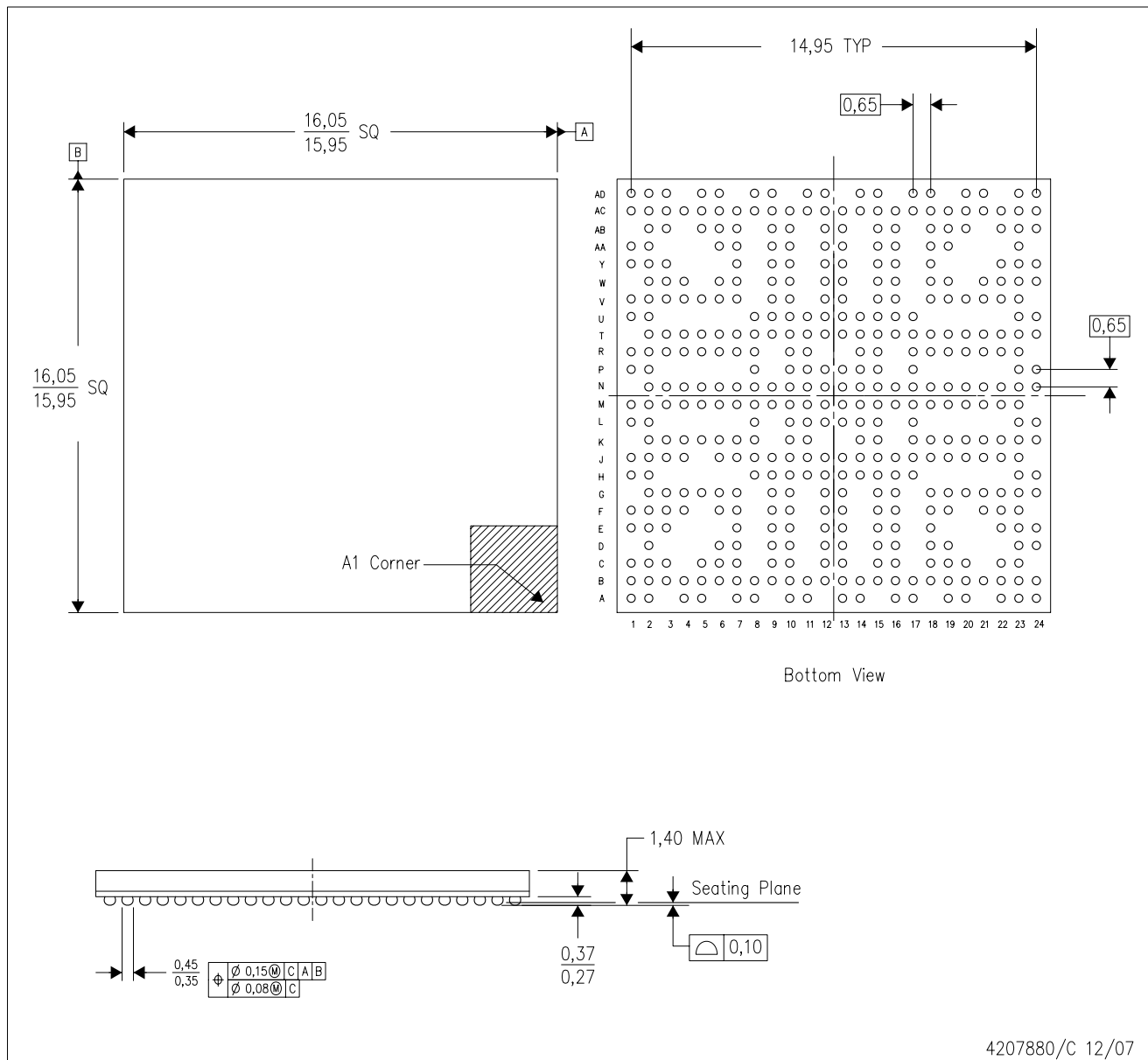

- NOTES:
- A. All linear dimensions are in millimeters.
 - B. This drawing is subject to change without notice.
 - C. Flip chip application only.
 - D. Lead-free die bump and solder ball.

CBC (S-PBGA-N515)

PLASTIC BALL GRID ARRAY

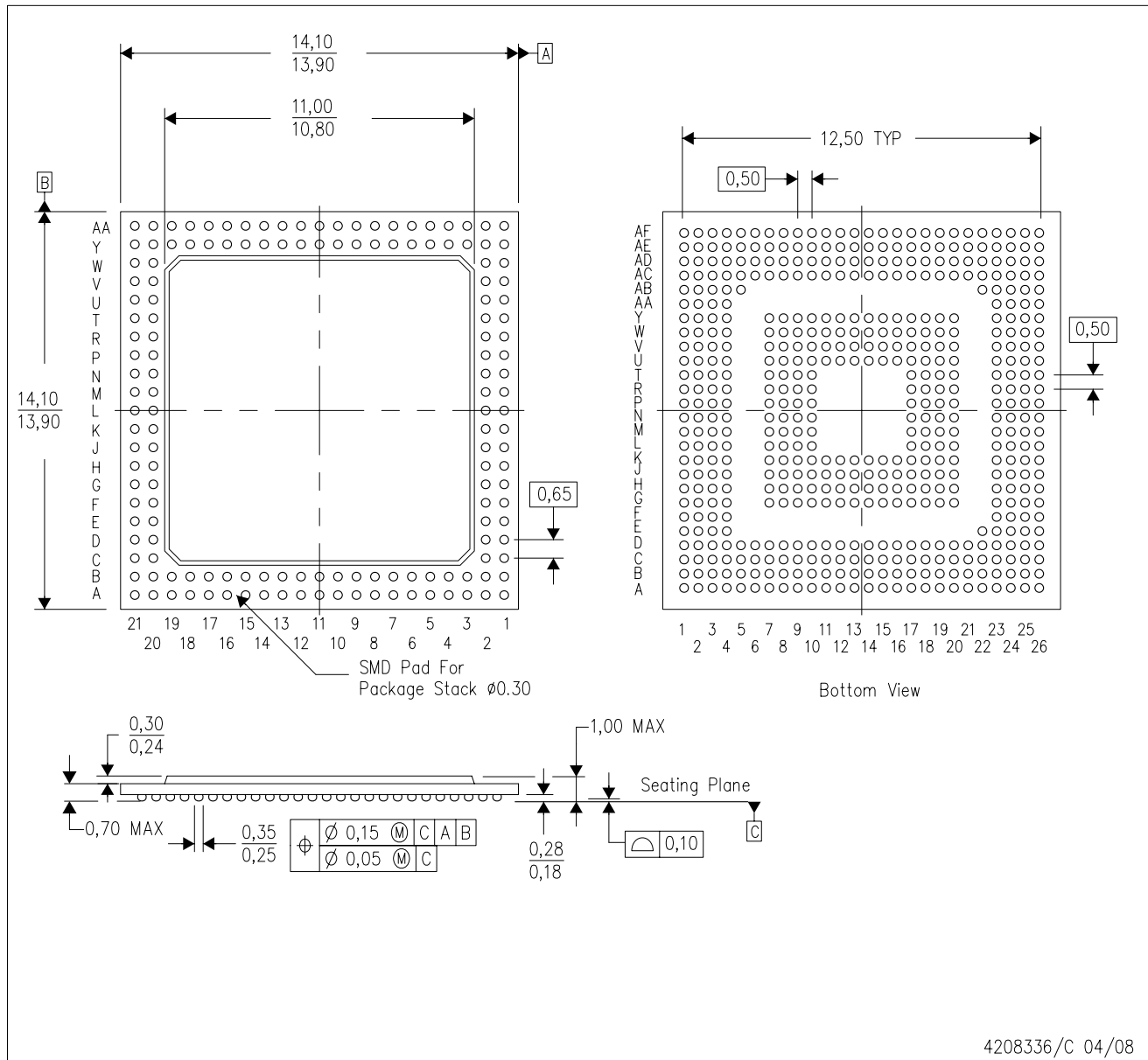

4208336/C 04/08

- NOTES:
- A. All linear dimensions are in millimeters.
 - B. This drawing is subject to change without notice.
 - C. Flip chip application only.
 - D. Lead-free die bump and solder ball.

IMPORTANT NOTICE

Texas Instruments Incorporated and its subsidiaries (TI) reserve the right to make corrections, modifications, enhancements, improvements, and other changes to its products and services at any time and to discontinue any product or service without notice. Customers should obtain the latest relevant information before placing orders and should verify that such information is current and complete. All products are sold subject to TI's terms and conditions of sale supplied at the time of order acknowledgment.

TI warrants performance of its hardware products to the specifications applicable at the time of sale in accordance with TI's standard warranty. Testing and other quality control techniques are used to the extent TI deems necessary to support this warranty. Except where mandated by government requirements, testing of all parameters of each product is not necessarily performed.

TI assumes no liability for applications assistance or customer product design. Customers are responsible for their products and applications using TI components. To minimize the risks associated with customer products and applications, customers should provide adequate design and operating safeguards.

TI does not warrant or represent that any license, either express or implied, is granted under any TI patent right, copyright, mask work right, or other TI intellectual property right relating to any combination, machine, or process in which TI products or services are used. Information published by TI regarding third-party products or services does not constitute a license from TI to use such products or services or a warranty or endorsement thereof. Use of such information may require a license from a third party under the patents or other intellectual property of the third party, or a license from TI under the patents or other intellectual property of TI.

Reproduction of TI information in TI data books or data sheets is permissible only if reproduction is without alteration and is accompanied by all associated warranties, conditions, limitations, and notices. Reproduction of this information with alteration is an unfair and deceptive business practice. TI is not responsible or liable for such altered documentation. Information of third parties may be subject to additional restrictions.

Resale of TI products or services with statements different from or beyond the parameters stated by TI for that product or service voids all express and any implied warranties for the associated TI product or service and is an unfair and deceptive business practice. TI is not responsible or liable for any such statements.

TI products are not authorized for use in safety-critical applications (such as life support) where a failure of the TI product would reasonably be expected to cause severe personal injury or death, unless officers of the parties have executed an agreement specifically governing such use. Buyers represent that they have all necessary expertise in the safety and regulatory ramifications of their applications, and acknowledge and agree that they are solely responsible for all legal, regulatory and safety-related requirements concerning their products and any use of TI products in such safety-critical applications, notwithstanding any applications-related information or support that may be provided by TI. Further, Buyers must fully indemnify TI and its representatives against any damages arising out of the use of TI products in such safety-critical applications.

TI products are neither designed nor intended for use in military/aerospace applications or environments unless the TI products are specifically designated by TI as military-grade or "enhanced plastic." Only products designated by TI as military-grade meet military specifications. Buyers acknowledge and agree that any such use of TI products which TI has not designated as military-grade is solely at the Buyer's risk, and that they are solely responsible for compliance with all legal and regulatory requirements in connection with such use.

TI products are neither designed nor intended for use in automotive applications or environments unless the specific TI products are designated by TI as compliant with ISO/TS 16949 requirements. Buyers acknowledge and agree that, if they use any non-designated products in automotive applications, TI will not be responsible for any failure to meet such requirements.

Following are URLs where you can obtain information on other Texas Instruments products and application solutions:

Products

| | |
|------------------------|--|
| Audio | www.ti.com/audio |
| Amplifiers | amplifier.ti.com |
| Data Converters | dataconverter.ti.com |
| DLP® Products | www.dlp.com |
| DSP | dsp.ti.com |
| Clocks and Timers | www.ti.com/clocks |
| Interface | interface.ti.com |
| Logic | logic.ti.com |
| Power Mgmt | power.ti.com |
| Microcontrollers | microcontroller.ti.com |
| RFID | www.ti-rfid.com |
| OMAP Mobile Processors | www.ti.com/omap |
| Wireless Connectivity | www.ti.com/wirelessconnectivity |

Applications

| | |
|-------------------------------|--|
| Automotive and Transportation | www.ti.com/automotive |
| Communications and Telecom | www.ti.com/communications |
| Computers and Peripherals | www.ti.com/computers |
| Consumer Electronics | www.ti.com/consumer-apps |
| Energy and Lighting | www.ti.com/energy |
| Industrial | www.ti.com/industrial |
| Medical | www.ti.com/medical |
| Security | www.ti.com/security |
| Space, Avionics and Defense | www.ti.com/space-avionics-defense |
| Video and Imaging | www.ti.com/video |

TI E2E Community Home Page

e2e.ti.com

Mailing Address: Texas Instruments, Post Office Box 655303, Dallas, Texas 75265
Copyright © 2012, Texas Instruments Incorporated